

PW-5000 Input Module Installation Manual

Part Number: PW5KxIN

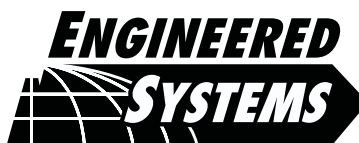
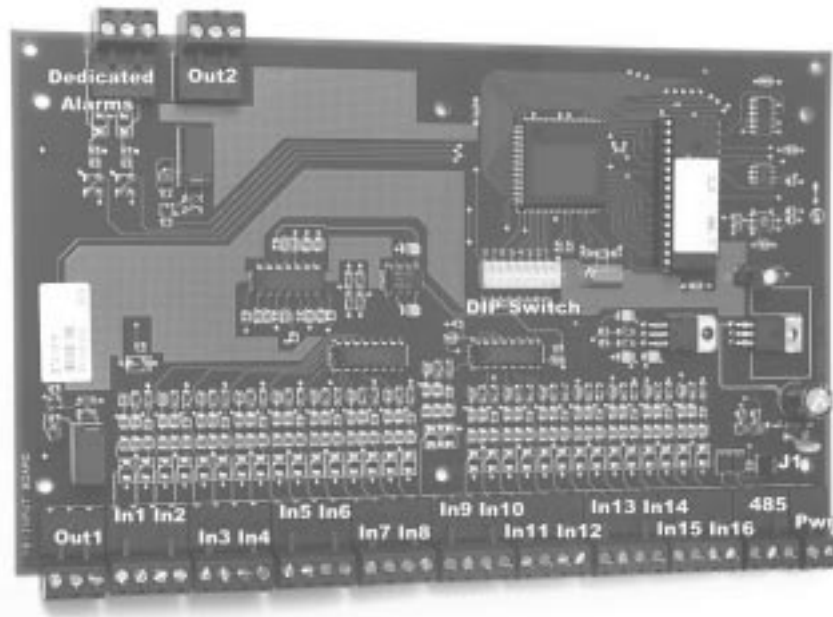

A division of Northern Computers, Inc.

TD1116 rev0100

Contents

Warnings and Cautions	4
Disclaimer	6
Product Liability; Mutual Indemnification	6
Unpacking Procedure	6
Shipping Instructions	7
Limited Warranty	7
Confidentiality	8
Description	9
Set Up	9
LED Operation	11
Power	11
Communications	11
Alarm Contact Wiring	12
Control Output Wiring	12
Mounting Options	13
Suggested Installation Sequence	13
Specifications	14
Wiring Diagram for Connectors 1 through 12	15
Wiring Diagram for Connectors 10 through 13	16

Warnings and Cautions

WARNING



Before installation, **TURN OFF** the external circuit breaker which supplies power to the system.

Before connecting the device to the power supply, verify that the output voltage is within specifications of the power supply.

Do not apply power to the system until **after** the installation has been completed. Personal injury or death could occur, and the equipment could be damaged beyond repair, if this precaution is not observed!

WARNING



Fire Safety and Liability Notice

Never connect card readers to any critical entry, exit door, barrier, elevator or gate without providing **an alternative exit** in accordance with all fire and life safety codes pertinent to the installation. These fire and safety codes vary from city to city and you must get approval from local fire officials whenever using an electronic product to control a door or other barrier. Use of egress buttons, for example, may be illegal in some cities. In most applications, single action exit without prior knowledge of what to do is a life safety requirement. Always make certain that any required approvals are obtained in writing. **DO NOT ACCEPT VERBAL APPROVALS, AS THEY ARE NOT VALID.**

Northern never recommends using the N-1000, N-800, N-500, PW-2000, PW-5000, EV-2000 or related products for use as a primary warning or monitoring system. Primary warning or monitoring systems should always meet local fire and safety code requirements. The installer must also test the system on a regular basis by instructing the end user in appropriate daily testing procedures. Failure to test a system regularly could make installer liable for damages to the end user if a problem occurs.

WARNING



EARTH ground all enclosures, for proper installation.

WARNING



Use suppressors on all door strikes. Use S-4 suppressors for installation. Northern Computers recommends only DC strikes.

CAUTION

IF ANY DAMAGE TO THE SHIPMENT IS NOTICED, A CLAIM MUST BE FILED WITH THE COMMERCIAL CARRIER RESPONSIBLE.

CAUTION

Electro-static discharge can damage CMOS integrated circuits and modules.

To prevent damage always follow these procedures:

Use static shield packaging and containers to transport all electronic components, including completed reader assemblies.

Handle all ESD sensitive components at an approved static controlled workstation. These workstations consist of a desk mat, floor mat and an ESD wrist strap. Workstations are available from various vendors.

NOTICE

This equipment has been tested and found to comply with the limits for a Class A digital device, pursuant to part 15 of the FCC Rules. These limits are designed to provide reasonable protection against harmful interference when the equipment is operated in a commercial environment. This equipment generates, uses, and can radiate radio frequency energy and, if not installed and used in accordance with the instruction manual, may cause harmful interference to radio communications. Operation of this equipment in a residential area is likely to cause harmful interference in which case the user will be required to correct the interference at his own expense.

NOTICE

This document and the data in it shall not be duplicated, used or disclosed to others for procurement or manufacture, except as authorized by and with the written permission of, Northern Computers, Inc. The information contained in this document or in the product itself is considered the exclusive property and trade secrets of Northern Computers, Inc. Copyright laws of the United States protect all information in this document or in the software product itself.

NOTICE

Any use of this product is subject to the terms and acceptance of the Northern Computers, Inc. Software Agreement. Please request a copy from Northern Computers, Inc., and review the agreement carefully.

Disclaimer

Product Liability; Mutual Indemnification

In the event that a Customer receives a claim that a Product or any component thereof has caused personal injury or damage to property of others, Customer shall immediately notify Northern in writing of all such claims. Northern shall defend or settle such claims and shall indemnify and hold Customer harmless for any costs or damages including reasonable attorneys' fees which Customer may be required to pay as a result of the defective Product or the negligence of Northern, its agents, or its employees.

Customer shall hold harmless and indemnify Northern from and against all claims, demands, losses and liability arising out of damage to property or injury to persons occasioned by or in connection with the acts or omissions of Customer and its agents and employees, and from and against all claims, demands, losses and liability for costs of fees, including reasonable attorneys' fees, in connection therewith.

Unpacking Procedure

CAUTION

If any damage to the shipment is noticed before unpacking, a claim must be filed with the commercial carrier.

All containers should be opened and unpacked carefully in order to prevent damage to the contents.

The following steps are used to unpack equipment in preparation for installation:

1. Open the container and remove the unit(s) and all packing material. Retain the container and all packing materials. They may be used again for reshipment of the equipment, if needed.
2. Inspect the contents for shortage. If items are missing items, contact the order entry department.
3. Visually check contents. If damage is discovered, perform the following:

If shipping caused damage to the unit, a claim must be filed with the commercial carrier.

If any other defect is apparent, call for a return authorization.

Shipping Instructions

To ship equipment back to Northern Computers, Inc.:

1. Contact the customer service department before returning equipment.
When you call please have available:
 - A description of the problem or reason you are returning the equipment.
 - Your original purchase order number, invoice number and if the unit is still under warranty.
 - A new purchase order number if the unit is not under warranty
2. Obtain the Return Authorization Number (RMA) from the customer service department.
3. Show the RMA number on all packages shipped. Packages, which are not marked with an RMA number will be refused at the factory and returned to you **COD**.
4. Carefully pack the equipment for shipment. Use the original packing material whenever possible

Limited Warranty

All Products sold or licensed by Northern include a warranty registration card which must be completed and returned to Northern by or on behalf of the end user in order for Northern to provide warranty service, repair, credit or exchange. All warranty work shall be handled through Customer which shall notify Northern and apply for a Return Merchandise Authorization (RMA) number prior to returning any Product for service, repair, credit or exchange. Northern warrants that its Products shall be free from defects in materials and workmanship for a period of two years from date of shipment of the Product to Customer. The warranty on Terminals, Printers, Communications Products and Upgrade kits is 90 days from date of shipment. Satisfaction of this warranty shall be limited to repair or replacement of Products which are defective or defective under normal use. Northern's warranty shall not extend to any Product which, upon examination, is determined to be defective as a result of misuse, improper storage, incorrect installation, operation or maintenance, alteration, modification, accident or unusual deterioration of the Product due to physical environments in excess of the limits set forth in Product manuals. THERE ARE NO WARRANTIES WHICH EXTEND BEYOND THIS PROVISION. THIS WARRANTY IS IN LIEU OF ALL OTHER WARRANTIES WHETHER EXPRESS, IMPLIED OR STATUTORY, INCLUDING IMPLIED WARRANTIES OF MERCHANTABILITY OR FITNESS FOR ANY PARTICULAR PURPOSE. NO REPRESENTATION OR WARRANTY OF THE DISTRIBUTOR SHALL EXTEND THE LIABILITY OR RESPONSIBILITY OF THE MANUFACTURER BEYOND THE TERMS OF THIS PROVISION. IN NO EVENT SHALL NORTHERN BE LIABLE FOR ANY RE-PROCUREMENT COSTS, LOSS OF PROFITS, LOSS OF USE, INCIDENTAL, CONSEQUENTIAL OR SPECIAL DAMAGES TO ANY PERSON RESULTING FROM THE USE OF NORTHERN'S PRODUCTS.

Confidentiality

All software, drawings, diagrams, specifications, catalogs, literature, manuals and other materials furnished by Northern relating to the design, use and service of the Products shall remain confidential and shall constitute proprietary rights of Northern and Customer agrees to treat such information as confidential. Customer shall acquire no rights in the design of the Products or the related materials except to use such information solely for the purpose of and only during the time it sells the Products. Customer shall not copy the design of any of the Products or use or cause to be used any Product design or related materials for its own benefit or for the benefit of any other party. The covenants contained in this section shall remain effective throughout the term of this Agreement and thereafter unless specifically waived by Northern in writing.

Description

The Input Board provides connections for 16 supervised inputs and 2 relay outputs. This board can be rack mounted, in which case, only one edge is accessible for wiring. Mounting the board flat increases the amount of available I/O slightly but also significantly decreases the number of boards that can be mounted in one enclosure.

Starting at the bottom of the rack-mount side of the board

- The first connector provides power to the board.
- The next connector provides communication with the Controller (PW5KxIC).
- Continuing up this edge, the next 8 connectors provide supervised input connections.
- The last connector on the rack-mount edge provides terminals for 1 relay output.

When the board is mounted flat, one additional relay output and two dedicated alarm inputs for cabinet tamper and power fault detection are provided on the opposite edge of the board.

Both form-C relay outputs are designed to handle dry-circuit signals. All of the inputs are capable of four-state supervision by using End-Of-Line (EOL) resistor termination except the two dedicated inputs. Communication to the control panel is accomplished via an RS-485 interface. This board requires 12 VDC input power.

When communication to the Controller is lost, this board will maintain all previous output settings at the time communication was lost.

Set Up

Jumper Settings:

Jumper	Setting	Default	Selected
J1	OFF	X	Port 1 RS-485 EOL terminator is not active
	ON		Port 1 RS-485 EOL terminator is active

Dip Switch Settings:

S8	S7	S6	S5	S4	S3	S2	S1	SELECTION
			OFF	OFF	OFF	OFF	OFF	ADDRESS 32
			OFF	OFF	OFF	OFF	ON	ADDRESS 1*
			OFF	OFF	OFF	ON	OFF	ADDRESS 2
			OFF	OFF	OFF	ON	ON	ADDRESS 3
			OFF	OFF	ON	OFF	OFF	ADDRESS 4
			OFF	OFF	ON	OFF	ON	ADDRESS 5
			OFF	OFF	ON	ON	OFF	ADDRESS 6
			OFF	OFF	ON	ON	ON	ADDRESS 7
			OFF	ON	OFF	OFF	OFF	ADDRESS 8
			OFF	ON	OFF	OFF	ON	ADDRESS 9
			OFF	ON	OFF	ON	OFF	ADDRESS 10
			OFF	ON	OFF	ON	ON	ADDRESS 11
			OFF	ON	ON	OFF	OFF	ADDRESS 12
			OFF	ON	ON	OFF	ON	ADDRESS 13
			OFF	ON	ON	ON	OFF	ADDRESS 14
			OFF	ON	ON	ON	ON	ADDRESS 15
			ON	OFF	OFF	OFF	OFF	ADDRESS 16
			ON	OFF	OFF	OFF	ON	ADDRESS 17
			ON	OFF	OFF	ON	OFF	ADDRESS 18
			ON	OFF	OFF	ON	ON	ADDRESS 19
			ON	OFF	ON	OFF	OFF	ADDRESS 20
			ON	OFF	ON	OFF	ON	ADDRESS 21
			ON	OFF	ON	ON	OFF	ADDRESS 22
			ON	OFF	ON	ON	ON	ADDRESS 23
			ON	ON	OFF	OFF	OFF	ADDRESS 24
			ON	ON	OFF	OFF	ON	ADDRESS 25
			ON	ON	OFF	ON	OFF	ADDRESS 26
			ON	ON	OFF	ON	ON	ADDRESS 27
			ON	ON	ON	OFF	OFF	ADDRESS 28
			ON	ON	ON	OFF	ON	ADDRESS 29
			ON	ON	ON	ON	OFF	ADDRESS 30
			ON	ON	ON	ON	ON	ADDRESS 31
	OFF	OFF						Reserved
	OFF	ON						9,600 BPS
	ON	OFF						19,200 BPS
	ON	ON						38,400 BPS*
OFF								Not Used*

* = Default

LED Operation

The Input board uses 2 on-board LEDs to provide status information during its power-up sequence and normal operation.

MODE	LED D1	LED D2	DESCRIPTION
Power-up Sequence	ON	OFF	Start Power-up, hardware setup
	OFF	ON	Testing RAM
	ON	ON	Testing ROM and completing initialization
	FLASH	ON	LED D1 flashes 4 times after Power-up is completed
Normal Operation	FLASH		This is the processor heart-beat LED. It flashes once every second. A short ON time (~20% duty cycle) indicates the board is off-line or has lost serial communication with the Controller board. A long ON time (~80% duty cycle) indicates the board is online and communicating with the Controller board.
		FLASH	Flash when there is activity on its Serial Port.

There are two additional LEDs that indicate relay status.

LED	DESCRIPTION	LED	DESCRIPTION		
D3	ON	Relay 1 energized or On	D4	ON	Relay 2 energized or On
D3	OFF	Relay 1 de-energized or Off	D4	OFF	Relay 2 de-energized or Off

Power

The Input Board accepts 12 VDC with an operating range of 10 to 16 VDC and consumes 350 mA of current. Locate power source as close to this board as possible. Connect power with minimum of 18AWG wires.

NOTE: POLARITY for 12 VDC power is important. Make sure the +12 VDC is connected to the terminal labeled +12V and the return is connected to the terminal labeled GND.

Communications

The Input Board communicates to the Controller through an RS-485 interface. The interface allows for multi-drop communication of up to 4,000 feet (1,200 m) total per port. Use two-twisted pair (minimum 24 AWG) with shield for communication (Belden 9842 or equiv.). The default speed of this port is 38.4Kbps but it can be downgraded to 19.2Kbps or 9.6Kbps if the line conditions or receiving equipment require it (see jumper and DIP switch settings).

For Wiring to an RS-485 port:

1. TR+ is the plus side of the transmit and receive differential signal
2. TR- is the negative side of the transmit and receive differential signal.
3. GND is the signal ground. The wiring for this signal is required and **NOT** optional. This signal must **NOT** be connected to chassis GND.
4. Use 24 AWG low capacitance, two-twisted-pair, shielded cable (Belden 9842 or equiv.).

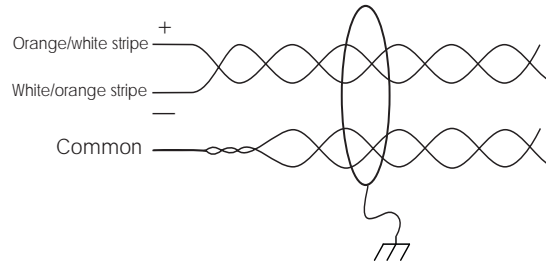

Note: For N-485 Communication Connections, twist the blue pair together and use as the common; use the orange pair as your data pair, observing polarity. Connect the external drain shield to the appropriate earth ground on one end.

- When daisy-chaining RS-485 ports together connect the TR+ wires from the upstream and downstream boards to the TR+ terminal and likewise, connect the TR- wires from the upstream and downstream boards to the TR- terminal.

By factory default J1 is set open. If this board is the last board on the RS-485 bus, install jumper J1 across both pins (closed). Closing J1 provides the bus termination required.

Alarm Contact Wiring

Inputs 1 through 16 may be configured to use normally open or normally closed contacts and non-supervised or supervised (with standard $\pm 1\%$ tolerance 1K ohm). All 16 inputs can be configured to monitor general-purpose alarm sensors or can be used as control inputs.

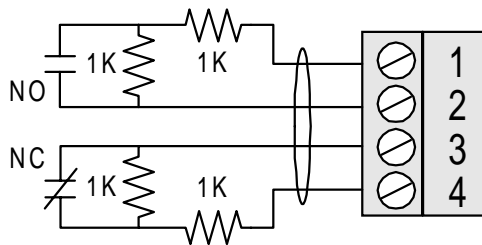

Additional inputs TMP and PFL are typically used for monitoring cabinet tamper and power failure respectively. These two inputs are not supervised and are not accessible when the board is rack mounted. These inputs are used when this board is mounted remotely mounted and cannot take advantage of the tamper and power fail detect inputs on the controller board. If these inputs are not used, install a short piece of wire at the input to indicate safe condition.

Input configuration, including sensitivity and hold time, is set via host software.

Control Output Wiring

Two form-C relay contacts are provided for controlling other devices. Each may be assigned to a general-purpose output. They are configurable as standard (energize to activate) or fail-safe (de-energize to activate) by the host software.

The energized or ON time of each relay can be configured using pulse control for single or repeating pulses by the host software. The energized or ON time of a single pulse can be extended up to 24 hours. For repeating pulses, the on/off time can be defined in 0.1 second increments and repeated up to 255 times.

Both relays 1 & 2 are rated for dry contact signal or load switching. While they are sized to handle typical loads, load switching can cause abnormal contact wear and premature contact failure. Switching of inductive loads (e.g., strikes) also causes EMI (electromagnetic interference) which may interfere with normal operation of other equipment. To minimize premature contact failure and to increase system reliability, a contact protection circuit is highly recommended. The following circuit is suggested. Locate the protection circuit as close to the load as possible (within 12 inches [30 cm]), as the effectiveness of the circuit will decrease as the distance from the load increases.

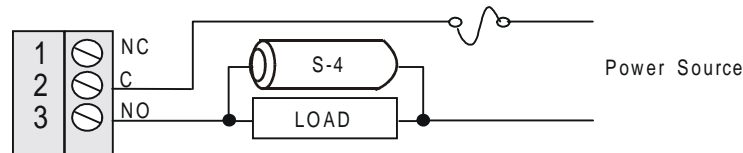

Relay 2 is a general-purpose relay output and is not available when the board is rack mounted.

Use sufficiently large gauge of wires for the load current so as to avoid voltage loss.

Mounting Options

This board can be mounted on-edge in the rack-mount enclosure provided by Northern Computers or it can be mounted flat against any surface using standoffs under the mounting holes provided in each of the four corners of this board.

When this board is rack-mounted, the connectors for one general-purpose output, and two dedicated inputs, are not accessible and should not be used.

The most common reason for mounting a board flat is that it is installed remotely to be located near the alarms being monitored. In this case, mount it in its own enclosure. Use the two dedicated inputs to monitor cabinet tamper and power fault. The additional general-purpose output provided allows for control of a local horn or other equipment.

Suggested Installation Sequence

1. Set Jumpers and DIP-switches.
2. Mount this board in the appropriate enclosure – If this board is being mounted in a rack, the component side of the board is to your right as you face the rack.
3. Connect the communications and power supply to the circuit boards with the Power Supply Harness.

WARNING: DO NOT CONNECT THE POWER SUPPLY TO THE AC SOCKET UNTIL ALL WIRING HAS BEEN INSTALLED AND RECHECKED.

4. Connect wiring to alarm input sensors or install jumper wire as appropriate.
5. Connect relay output wiring as appropriate.
6. Connect communications wiring to the Intelligent Controller.
7. Recheck wiring for correct connections and continuity.
8. When all boards have been installed, connect the Power Supply Cord for proper connections and power.
9. Setup the panel controls using the host software.

Specifications

The Input board is for use in low voltage, class 2 circuits only.

Primary power:

12 VDC \pm 10% 350 mA with an operating range of 10 VDC to 16 VDC

Relay contacts:

Relays 1 & 2 outputs, Form-C, 2A @ 28 VDC, resistive

Inputs:

16 supervised, End of Line resistors 1K ohm standard \pm 1% tolerance
2 unsupervised dedicated inputs

Communication:

RS-485 9,6400 to 38,400bps

Wire requirements:

Power	1 twisted pair, 18AWG
RS-485	24AWG, 4,000feet (1,200m) max., two twisted-pair with shield (120 ohm, 23 pf, Belden 9482 or equiv.)
Alarm inputs	1 twisted pair per input, 30 ohms max.
Outputs	As required for the load

Mechanical:

Dimension	5.5" (140 mm) W x 9" (229 mm) L x 1" (25 mm) H
Weight	12 oz. (340 g) nominal

Environment:

Temperature	-55°C to +85°C, storage, 0°C to +70°C, operating
Humidity	0% to 95% RHNC

Wiring Diagram for Connectors 1 through 12

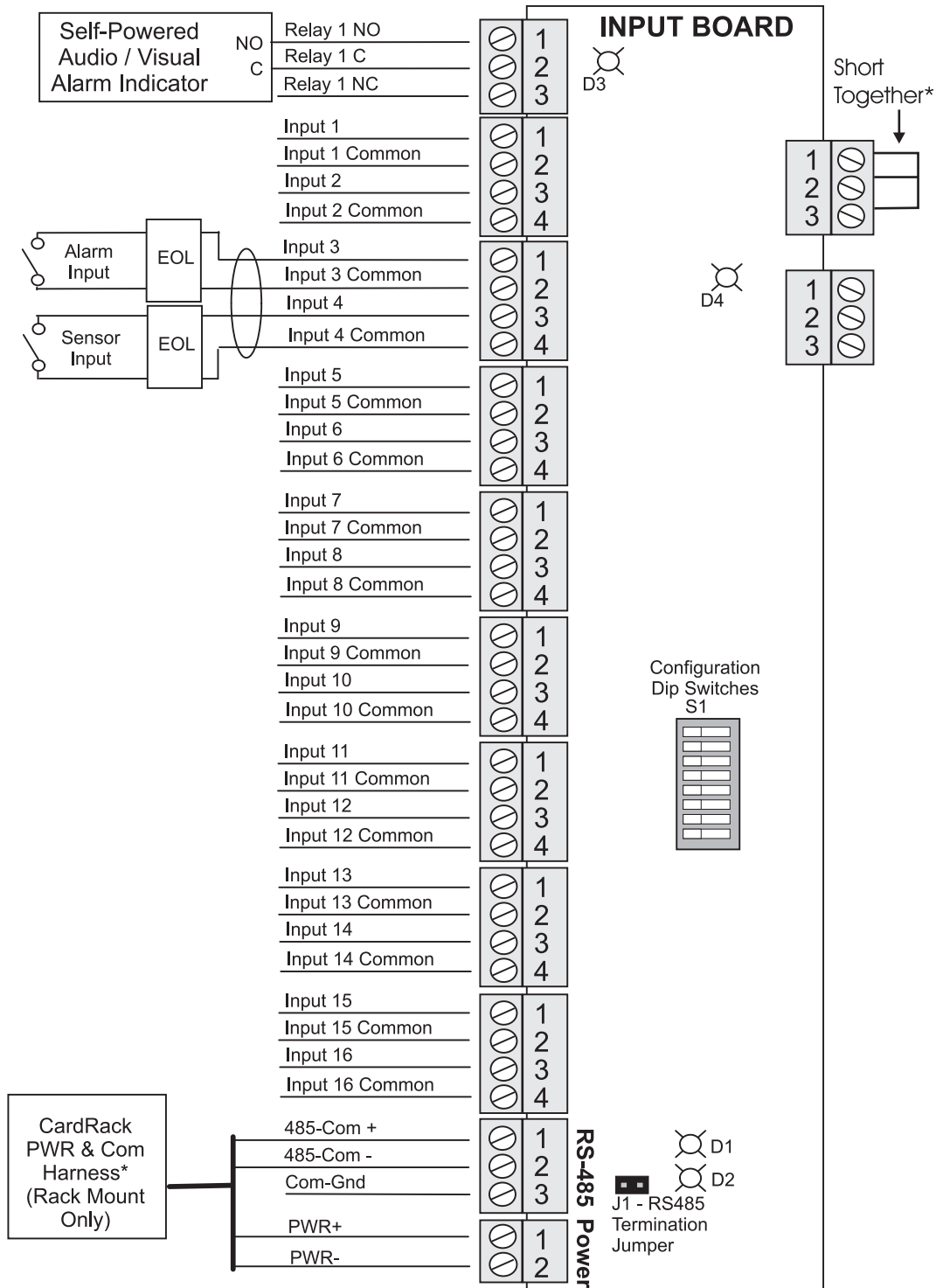

*Rack mount configuration

Note: For N-485 Communication Connections, twist the blue pair together and use as the common; use the orange pair as your data pair, observing polarity. Connect the external drain shield to the appropriate earth ground on one end.

Wiring Diagram for Connectors 10 through 13

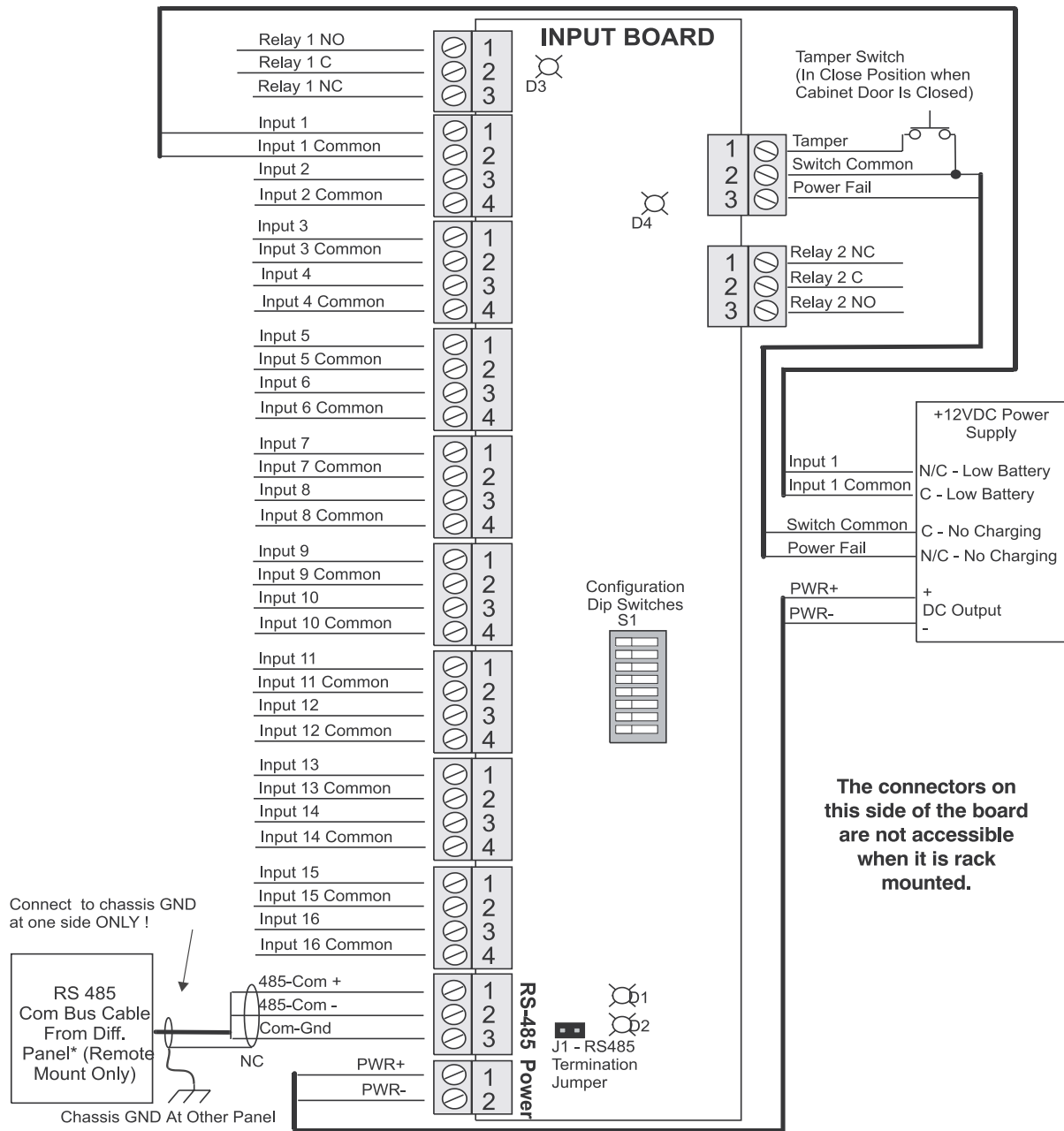

*Remote mount configuration

Note: For N-485 Communication Connections, twist the blue pair together and use as the common; use the orange pair as your data pair, observing polarity. Connect the external drain shield to the appropriate earth ground on one end.

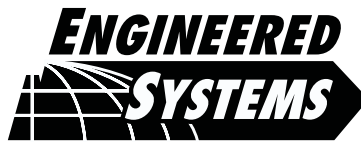

A division of Northern Computers, Inc.

SHAPING SECURITY THROUGH CREATIVE SOLUTIONS

5007 South Howell Avenue • Milwaukee, WI 53207 USA

Tel (414) 769-5980 • (800) 323-4576

Fax (414) 769-5989 • www.nciaccess.com