

PW-5000 Two Reader Module Installation Manual

Part Number: PW5KxR2

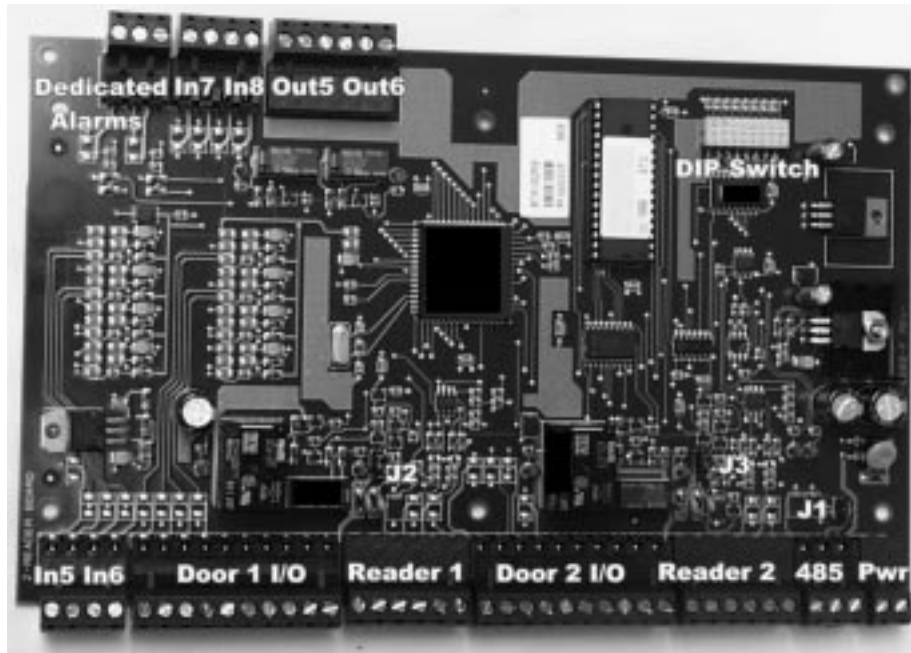

TD1119 rev0100

Contents

Warnings and Cautions	4
Disclaimer	6
Product Liability; Mutual Indemnification	6
Unpacking Procedure	6
Shipping Instructions	7
Limited Warranty	7
Confidentiality	8
Description	9
Set Up	9
LED Operation	11
Power	11
Communications	11
Reader Wiring	12
Alarm Contact Wiring	13
Control Output Wiring	13
Mounting Options	14
Suggested Installation Sequence	14
Specification	15
Wiring Diagram for Connectors 1 through 7	16
Wiring Diagram for Connectors 6 through 10	17

Warnings and Cautions

WARNING



Before installation, **TURN OFF** the external circuit breaker which supplies power to the system.

Before connecting the device to the power supply, verify that the output voltage is within specifications of the power supply.

Do not apply power to the system until **after** the installation has been completed. Personal injury or death could occur, and the equipment could be damaged beyond repair, if this precaution is not observed!

WARNING



Fire Safety and Liability Notice

Never connect card readers to any critical entry, exit door, barrier, elevator or gate without providing **an alternative exit** in accordance with all fire and life safety codes pertinent to the installation. These fire and safety codes vary from city to city and you must get approval from local fire officials whenever using an electronic product to control a door or other barrier. Use of egress buttons, for example, may be illegal in some cities. In most applications, single action exit without prior knowledge of what to do is a life safety requirement. Always make certain that any required approvals are obtained in writing. **DO NOT ACCEPT VERBAL APPROVALS, AS THEY ARE NOT VALID.**

Northern never recommends using the N-1000, N-800, N-500, PW-2000, PW-5000, EV-2000 or related products for use as a primary warning or monitoring system. Primary warning or monitoring systems should always meet local fire and safety code requirements. The installer must also test the system on a regular basis by instructing the end user in appropriate daily testing procedures. Failure to test a system regularly could make installer liable for damages to the end user if a problem occurs.

WARNING



EARTH ground all enclosures, for proper installation.

WARNING



Use suppressors on all door strikes. Use S-4 suppressors for installation. Northern Computers recommends only DC strikes.

CAUTION

IF ANY DAMAGE TO THE SHIPMENT IS NOTICED, A CLAIM MUST BE FILED WITH THE COMMERCIAL CARRIER RESPONSIBLE.

CAUTION

Electro-static discharge can damage CMOS integrated circuits and modules.

To prevent damage always follow these procedures:

Use static shield packaging and containers to transport all electronic components, including completed reader assemblies.

Handle all ESD sensitive components at an approved static controlled workstation. These workstations consist of a desk mat, floor mat and an ESD wrist strap. Workstations are available from various vendors.

NOTICE

This equipment has been tested and found to comply with the limits for a Class A digital device, pursuant to part 15 of the FCC Rules. These limits are designed to provide reasonable protection against harmful interference when the equipment is operated in a commercial environment. This equipment generates, uses, and can radiate radio frequency energy and, if not installed and used in accordance with the instruction manual, may cause harmful interference to radio communications. Operation of this equipment in a residential area is likely to cause harmful interference in which case the user will be required to correct the interference at his own expense.

NOTICE

This document and the data in it shall not be duplicated, used or disclosed to others for procurement or manufacture, except as authorized by and with the written permission of, Northern Computers, Inc. The information contained in this document or in the product itself is considered the exclusive property and trade secrets of Northern Computers, Inc. Copyright laws of the United States protect all information in this document or in the software product itself.

NOTICE

Any use of this product is subject to the terms and acceptance of the Northern Computers, Inc. Software Agreement. Please request a copy from Northern Computers, Inc., and review the agreement carefully.

Disclaimer

Product Liability; Mutual Indemnification

In the event that a Customer receives a claim that a Product or any component thereof has caused personal injury or damage to property of others, Customer shall immediately notify Northern in writing of all such claims. Northern shall defend or settle such claims and shall indemnify and hold Customer harmless for any costs or damages including reasonable attorneys' fees which Customer may be required to pay as a result of the defective Product or the negligence of Northern, its agents, or its employees.

Customer shall hold harmless and indemnify Northern from and against all claims, demands, losses and liability arising out of damage to property or injury to persons occasioned by or in connection with the acts or omissions of Customer and its agents and employees, and from and against all claims, demands, losses and liability for costs of fees, including reasonable attorneys' fees, in connection therewith.

Unpacking Procedure

CAUTION

If any damage to the shipment is noticed before unpacking, a claim must be filed with the commercial carrier.

All containers should be opened and unpacked carefully in order to prevent damage to the contents.

The following steps are used to unpack equipment in preparation for installation:

1. Open the container and remove the unit(s) and all packing material. Retain the container and all packing materials. They may be used again for reshipment of the equipment, if needed.
2. Inspect the contents for shortage. If items are missing items, contact the order entry department.
3. Visually check contents. If damage is discovered, perform the following:

If shipping caused damage to the unit, a claim must be filed with the commercial carrier.

If any other defect is apparent, call for a return authorization.

Shipping Instructions

To ship equipment back to Northern Computers, Inc.:

1. Contact the customer service department before returning equipment.
When you call please have available:
 - A description of the problem or reason you are returning the equipment.
 - Your original purchase order number, invoice number and if the unit is still under warranty.
 - A new purchase order number if the unit is not under warranty
2. Obtain the Return Authorization Number (RMA) from the customer service department.
3. Show the RMA number on all packages shipped. Packages, which are not marked with an RMA number will be refused at the factory and returned to you **COD**.
4. Carefully pack the equipment for shipment. Use the original packing material whenever possible

Limited Warranty

All Products sold or licensed by Northern include a warranty registration card which must be completed and returned to Northern by or on behalf of the end user in order for Northern to provide warranty service, repair, credit or exchange. All warranty work shall be handled through Customer which shall notify Northern and apply for a Return Merchandise Authorization (RMA) number prior to returning any Product for service, repair, credit or exchange. Northern warrants that its Products shall be free from defects in materials and workmanship for a period of two years from date of shipment of the Product to Customer. The warranty on Terminals, Printers, Communications Products and Upgrade kits is 90 days from date of shipment. Satisfaction of this warranty shall be limited to repair or replacement of Products which are defective or defective under normal use. Northern's warranty shall not extend to any Product which, upon examination, is determined to be defective as a result of misuse, improper storage, incorrect installation, operation or maintenance, alteration, modification, accident or unusual deterioration of the Product due to physical environments in excess of the limits set forth in Product manuals. THERE ARE NO WARRANTIES WHICH EXTEND BEYOND THIS PROVISION. THIS WARRANTY IS IN LIEU OF ALL OTHER WARRANTIES WHETHER EXPRESS, IMPLIED OR STATUTORY, INCLUDING IMPLIED WARRANTIES OF MERCHANTABILITY OR FITNESS FOR ANY PARTICULAR PURPOSE. NO REPRESENTATION OR WARRANTY OF THE DISTRIBUTOR SHALL EXTEND THE LIABILITY OR RESPONSIBILITY OF THE MANUFACTURER BEYOND THE TERMS OF THIS PROVISION. IN NO EVENT SHALL NORTHERN BE LIABLE FOR ANY RE-PROCUREMENT COSTS, LOSS OF PROFITS, LOSS OF USE, INCIDENTAL, CONSEQUENTIAL OR SPECIAL DAMAGES TO ANY PERSON RESULTING FROM THE USE OF NORTHERN'S PRODUCTS.

Confidentiality

All software, drawings, diagrams, specifications, catalogs, literature, manuals and other materials furnished by Northern relating to the design, use and service of the Products shall remain confidential and shall constitute proprietary rights of Northern and Customer agrees to treat such information as confidential. Customer shall acquire no rights in the design of the Products or the related materials except to use such information solely for the purpose of and only during the time it sells the Products. Customer shall not copy the design of any of the Products or use or cause to be used any Product design or related materials for its own benefit or for the benefit of any other party. The covenants contained in this section shall remain effective throughout the term of this Agreement and thereafter unless specifically waived by Northern in writing.

Description

The Two Reader Board provides support for up to two access control doors by providing connections for Wiegand or Clock/Data type readers, supervised inputs and relay outputs. This board can be rack mounted, in which case, only one edge is accessible for wiring. Mounting the board flat increases the amount of available I/O slightly but also significantly decreases the number of boards that can be mounted in one enclosure.

The I/O terminals are organized to support two doors. Starting at the bottom of the rack-mount side of the board, the first connector provides power to the board. The next connector provides communication with the Intelligent Controller (PW5KxIC). The next set of terminals is used to connect reader 2. The next set of terminals is used to connect the I/O typically associated with reader 2, namely the Door Status and REX status inputs and the Door Lock and Lock Status relay outputs. Continuing up this edge the next two connectors provide the reader and associated I/O terminals for reader 1. The last connector on the rack-mount edge provides terminals for two additional general-purpose alarm inputs

When the board is mounted flat, two additional relay outputs and two additional general-purpose alarm inputs are available along with two dedicated alarm inputs for cabinet tamper and power fault detection on the opposite edge of the board.

The reader interface accepts a Wiegand signal of Data 1 and Data 0 or a Clock and Data signal and provides 5VDC or 12VDC reader power, a tri-stated LED control and buzzer control. Two of the six form-C relay outputs are sized for the inductive load of door locks and the other four are designed to handle dry-circuit signals. All of the inputs are capable of four-state supervision except the two dedicated inputs. Communication to the control panel is accomplished via an RS-485 interface. This board requires 12VDC input power.

When communication to the control panel is lost this board can grant access based on facility code only. General purpose outputs will retain the setting at the time communication was lost. Up to eight facility codes may be active in each PW5KxR2. Keypad input must follow the reader input format and is in place of or multiplexed with the reader data.

Set Up

Jumper Settings:

Jumper	Setting	Default	Selected
J1	OFF	★	Port 1 RS-485 EOL terminator is not active
	ON		Port 1 RS-485 EOL terminator is active
J2	5	★	Reader 1 Power Terminal provides 5 Vdc
	12		Reader 1 Power Terminal provides 12 Vdc
J3	5	★	Reader 2 Power Terminal provides 5 Vdc
	12		Reader 2 Power Terminal provides 12 Vdc

Dipswitch Settings:

S8	S7	S6	S5	S4	S3	S2	S1	SELECTION
			OFF	OFF	OFF	OFF	OFF	ADDRESS 32
			OFF	OFF	OFF	OFF	ON	ADDRESS 1*
			OFF	OFF	OFF	ON	OFF	ADDRESS 2
			OFF	OFF	OFF	ON	ON	ADDRESS 3
			OFF	OFF	ON	OFF	OFF	ADDRESS 4
			OFF	OFF	ON	OFF	ON	ADDRESS 5
			OFF	OFF	ON	ON	OFF	ADDRESS 6
			OFF	OFF	ON	ON	ON	ADDRESS 7
			OFF	ON	OFF	OFF	OFF	ADDRESS 8
			OFF	ON	OFF	OFF	ON	ADDRESS 9
			OFF	ON	OFF	ON	OFF	ADDRESS 10
			OFF	ON	OFF	ON	ON	ADDRESS 11
			OFF	ON	ON	OFF	OFF	ADDRESS 12
			OFF	ON	ON	OFF	ON	ADDRESS 13
			OFF	ON	ON	ON	OFF	ADDRESS 14
			OFF	ON	ON	ON	ON	ADDRESS 15
			ON	OFF	OFF	OFF	OFF	ADDRESS 16
			ON	OFF	OFF	OFF	ON	ADDRESS 17
			ON	OFF	OFF	ON	OFF	ADDRESS 18
			ON	OFF	OFF	ON	ON	ADDRESS 19
			ON	OFF	ON	OFF	OFF	ADDRESS 20
			ON	OFF	ON	OFF	ON	ADDRESS 21
			ON	OFF	ON	ON	OFF	ADDRESS 22
			ON	OFF	ON	ON	ON	ADDRESS 23
			ON	ON	OFF	OFF	OFF	ADDRESS 24
			ON	ON	OFF	OFF	ON	ADDRESS 25
			ON	ON	OFF	ON	OFF	ADDRESS 26
			ON	ON	OFF	ON	ON	ADDRESS 27
			ON	ON	ON	OFF	OFF	ADDRESS 28
			ON	ON	ON	OFF	ON	ADDRESS 29
			ON	ON	ON	ON	OFF	ADDRESS 30
			ON	ON	ON	ON	ON	ADDRESS 31
	OFF	OFF						Reserved
	OFF	ON						9,600 BPS
	ON	OFF						19,200 BPS
	ON	ON						38,400 BPS*
OFF								Not Used*

* = Default

LED Operation

The Reader board uses two on-board LEDs D79 & D80 to provide status information during its Power-up sequence as well as normal operation.

MODE	LED D79	LED D80	DESCRIPTION
Power-up Sequence	ON	OFF	Start Power-up, hardware setup
	OFF	ON	Testing RAM
	ON	ON	Testing ROM and completing initialization
	FLASH	ON	LED D79 flashes 4 times after Power-up is completed
Normal Operation	FLASH		This is the processor heart-beat LED. It flashes once every second. A short ON time (~20% duty cycle) indicates the board is off-line or has lost serial communication with the Controller board. A long ON time (~80% duty cycle) indicates the board is online and communicating with the Controller board.
		FLASH	Flash when there is activity on its Serial Port.

In addition to the status LEDs, there are 6 additional relay status LEDs on board. When any relay is energized or ON, its corresponding status LED will become ON also. The LED will remain ON for as long as the relay is energized. The assignment for each relay status LED is shown in the following table.

RELAY#	1	2	3	4	5	6
LED	D73	D75	D74	D76	D77	D78

Power

The Two Reader Board accepts 12VDC with an operating range of 10 to 16VDC and consumes 400mA of current. Locate power source as close to this board as possible. Connect power with minimum of 18AWG wire. The input voltage is regulated to 5VDC. The regulated voltage or the 12VDC (pass through) is available for powering the readers. The selection is made via jumpers and is available at both reader connectors.

NOTE: POLARITY for 12VDC power is important. Make sure the +12 VDC is connected to the terminal labeled +12V and the return is connected to the terminal labeled GND.

Communications

The Two Reader Board communicates to host controller via an RS-485 interface. The interface allows for multi-drop communication of up to 4,000 feet (1,200 m) total per port. Use two twisted pair (minimum 24AWG) with shield for communication. The default speed of this port is 38.4Kbps but it can be downgraded to 19.2Kbps or 9.6Kbps if the line conditions or receiving equipment require it (see jumper and DIP switch settings).

For Wiring to an RS-485 port:

1. TR+ is the plus side of the transmit and receive differential signal
2. TR- is the negative side of the transmit and receive differential signal.
3. GND is the signal ground. The wiring for this signal is required and **NOT optional**. This signal must NOT be connected to chassis GND.
4. Use 24 AWG low capacitance, two twisted-pair, shielded cable (Belden 9842 or equiv.).

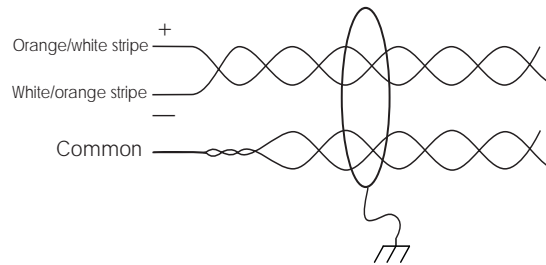

Note: For N-485 Communication Connections, twist the blue pair together and use as the common; use the orange pair as your data pair, observing polarity. Connect the external drain shield to the appropriate earth ground on one end.

5. When daisy-chaining RS-485 ports together connect the TR+ wires from the upstream and downstream boards to the TR+ terminal and likewise, connect the TR- wires from the upstream and downstream boards to the TR- terminal.

By factory default J1 is set open. If this board is the last board on the RS-485 bus, install jumper J1 across both pins (closed). Closing J1 provides the bus termination required.

Reader Wiring

Each reader port supports a reader with TTL interface. Power to the reader is selectable as 5VDC or 12VDC (pass-through). This selection is done via setting of jumpers J2 for reader 1 and J3 for reader 2. Set jumper at position "5" for 5VDC or "12" for pass-through 12VDC. The factory defaults set J2 and J3 to "5".

For wiring to a reader port:

Terminal	Typ Wire Color	Wiegand Reader	Clock/Data Reader
1	Red	Power (5 or 12 Vdc)	Power (5 or 12 Vdc)
2	Brown	LED control	LED control
3	Yellow	Beeper Control	Beeper Control
4	White	Data 1 Signal	Clock Signal
5	Green	Data 0 Signal	Data Signal
6	Black	Common	Common

The LED control terminal in each reader port can be configured via host software to support one-wire single or bi-colored reader LED. An example of the most common configuration is shown below. If Beeper control is not used, its terminal can be programmed to be the 2nd wire for the two-wire bi-colored reader LED.

Single Wire Reader LED Control Configuration

LED Output->	High	Tri-States	Low
Single Color LED	LED On	LED Off	LED Off
Bi-Color LED	Green LED On	Both LEDs Off	Red LED On

To fully utilize each reader port, a 6-conductor cable (18AWG) is required. Reader port configuration is set via host software.

Alarm Contact Wiring

Inputs 1 to 8 may be configured to use normally open or normally closed contacts and non-supervised or supervised (with standard ±1 tolerance 1K ohm). Four of these inputs have default functional definitions, but all eight can be configured to monitor general-purpose alarm sensors.

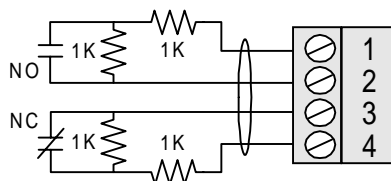

By default, Input 1 is defined as the Door Status Input corresponding to reader 1 and Input 2 is defined as the REX input corresponding to reader 1. Also by default, Input 3 is defined as the Door Status Input corresponding to reader 2 and Input 4 is defined as the REX input corresponding to reader 2.

Inputs 5, 6, 7, and 8 are general purpose inputs that can be used to monitor alarm sensors or can be used as control inputs. Inputs 7 and 8 are not accessible when the board is rack mounted.

Inputs TMP and PFL are typically used for monitoring cabinet tamper and power failure respectively. These 2 inputs are not supervised and are not accessible when the board is rack mounted. These inputs were primarily provided for the case when this board is mounted remotely and can not take advantage of the tamper and power fail detect inputs on the controller board. If these inputs are not used, install a short piece of wire at the input to indicated safe condition.

Input configuration including debounce and hold time is set via host software.

Control Output Wiring

Six form-C relay contacts are provided for controlling door strike or other devices. Each may be assigned to door-related functions or general-purpose output. They are configurable as standard (energize to activate) or fail-safe (de-energize to activate) via host software.

The energized or ON time of each relay can be configured using Pulse control for single or repeating pulses via host software. The energized or ON time for a single pulse can be extended up to 24 hours. For repeating pulses, the on/off time can be defined in 0.1 second increments and be repeated up to 255 times.

Relays 1 and 3 are rated for and normally used to control the door locks associated with readers 1 and 2 respectively. While Relays 1 and 3 are sized to handle the typical loads generated by electrical locks, load switching can cause abnormal contact wear and premature contact failure. Switching of inductive loads (i.e., strike) also causes EMI (electromagnetic interference) which may interfere with normal operation of other equipment. To minimize premature contact failure and to increase system reliability, contact protection circuit is highly recommended. The following two circuits are suggested. Locate the protection circuit as close to the load as possible (within 12 inches [30cm]), as the effectiveness of the circuit will decrease as the distance from the load increases. (See diagram to follow.)

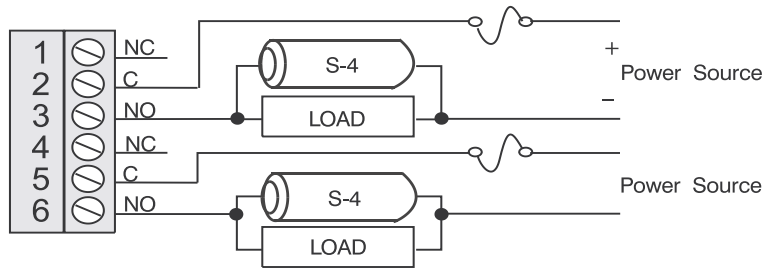

Relays 2 and 4 are dry-circuit level signal relays typically used to indicate the status of the door lock. Relays 5 and 6 are general-purpose relay outputs and are not available when the board is rack mounted.

Use sufficiently large gauge of wires for the load current to avoid voltage loss.

Mounting Options

This board can be mounted on-edge in the rack-mount enclosure provided by Northern Computers or it can be mounted flat against any surface using standoffs under the mounting holes provided in each of the four corners of this board.

When this board is rack-mounted, the connectors for two general-purpose inputs, two general-purpose outputs, and two dedicated inputs are not accessible and should not be used.

The most common reason for mounting a board flat is that it is being installed remotely to be located near the door(s) being monitored. In this case it will be mounted in its own enclosure creating the need to monitor cabinet tamper and power fault detection inputs. The two additional general-purpose inputs and outputs provided allow for the monitoring of extra alarm sensors and control of local horns or other equipment.

Suggested Installation Sequence

1. Set Jumpers and DIP switches.
2. Mount this board in the appropriate enclosure – If this board is being mounted in a rack, the component side of the board is to your right as you face the rack.
3. Connect the communications and power supply to the circuit boards with the Power Supply Harness.

WARNING: DO NOT CONNECT THE POWER SUPPLY TO THE AC SOCKET UNTIL ALL WIRING HAS BEEN INSTALLED AND RECHECKED.

4. Connect wiring to the reader interfaces as appropriate.

5. Connect wiring to alarm input sensors or install jumper wire as appropriate.
6. Connect relay output wiring as appropriate.
7. Connect communications wiring to the Intelligent Controller.
8. Recheck wiring for correct connections and continuity.
9. When all boards have been installed, connect the Power Supply Cord for proper connections and power.
10. Setup the panel controls using the host software.

Specification

The Two Reader is for use in low voltage, class 2 circuits only.

Primary power:

12VDC \pm 10% 400mA with an operating range of 10VDC to 16VDC

Relay contacts:

Relays 1 & 3 outputs, Form-C, 5A @ 28VDC, resistive

Relays 2 & 4 & 5 & 6 outputs, Form-C, 2A @ 28VDC, resistive

Inputs:

8 supervised, End of Line resistors 1k ohm \pm 1% tolerance

2 unsupervised dedicated inputs

Reader interface

Reader power 5VDC(5 - 6.2) or 12VDC (pass-through) 150mA max. each

Reader LED output TTL compatible, high > 3V, low < 0.5V, 5mA source/sink max.

Reader buzzer output Open collector, 5VDC open circuit max. 10mA sink max.

Reader data inputs TTL compatible inputs

Communication:

RS-485 9,600 to 38,400 bps

Wire requirements:

Power 1 twisted pair, 18AWG

RS-485: 24AWG, 4,000feet (1,200m) max., 2-twisted pair with shield (120 Ω , 23pf) (Belden 9842 or equiv.)

Alarm inputs 1 twisted pair per input, 30 ohms max.

Outputs As required for the load

Readers 6 conductors, 18AWG, 500 feet (150m) max. shield and drain

Mechanical:

Dimension 5.5" (140mm) W x 9" (229mm) L x 1" (25mm) H

Weight 12 oz. (340g) nominal

Environment:

Temperature -55°C to $+85^{\circ}\text{C}$, storage, 0°C to $+70^{\circ}\text{C}$, operating

Humidity 0% to 95% RHNC

Wiring Diagram for Connectors 1 through 7

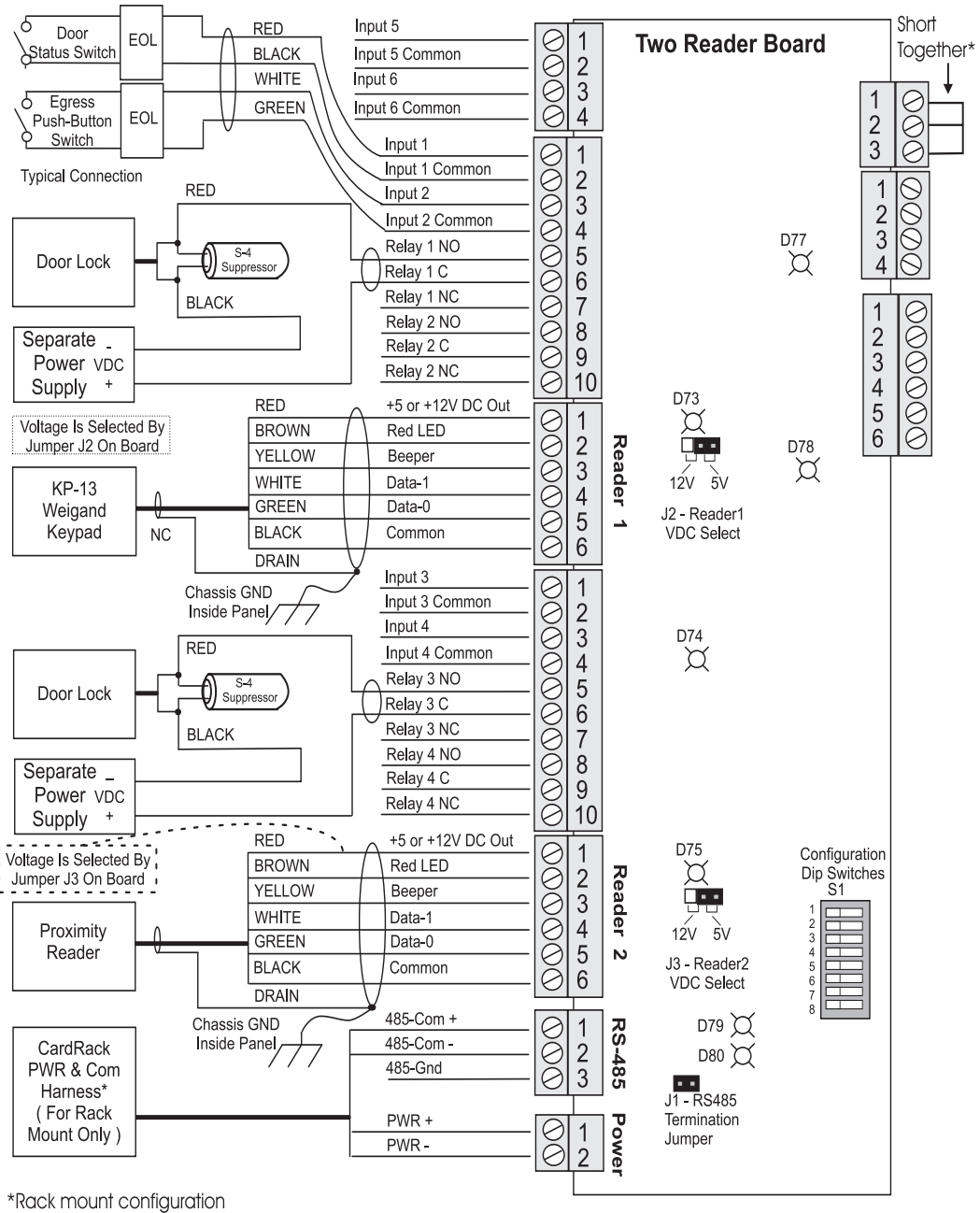

*Rack mount configuration

Note: For N-485 Communication Connections, twist the blue pair together and use as the common; use the orange pair as your data pair, observing polarity. Connect the external drain shield to the appropriate earth ground on one end.

Wiring Diagram for Connectors 6 through 10

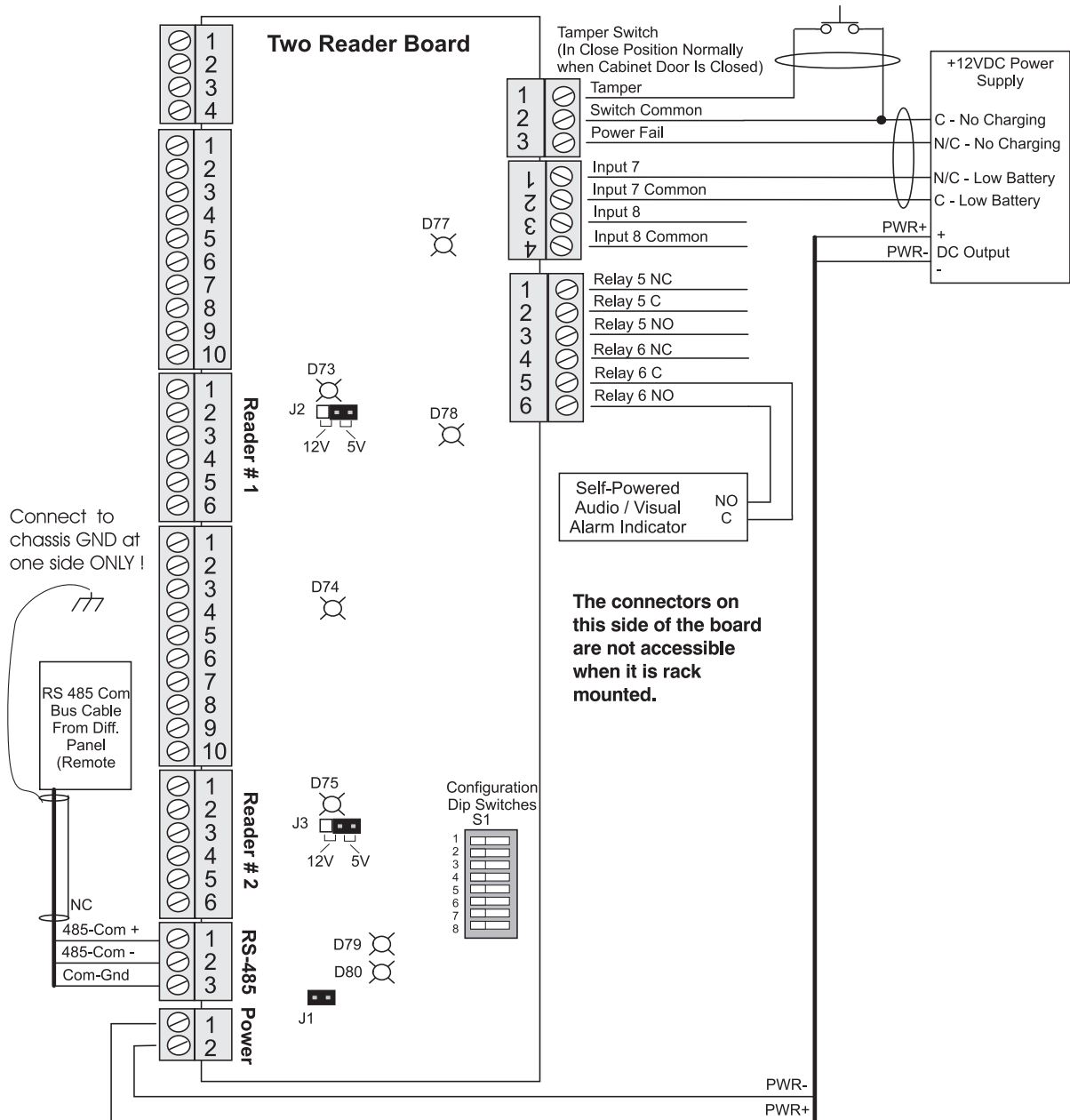

Note: For N-485 Communication Connections, twist the blue pair together and use as the common; use the orange pair as your data pair, observing polarity. Connect the external drain shield to the appropriate earth ground on one end.

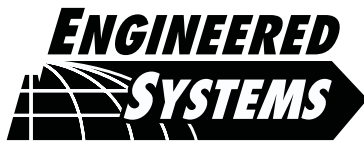

A division of Northern Computers, Inc.

SHAPING SECURITY THROUGH CREATIVE SOLUTIONS

5007 South Howell Avenue • Milwaukee, WI 53207 USA

Tel (414) 769-5980 • (800) 323-4576