



LU-202 Large Capacity Unit INSTALLATION MANUAL

Applied Machine: C6501/C6501P/C5501/C6500/C6500P/C5500/C65hc/C7000/C7000P/C6000/C70hc
 COLOR MFP: 65ppm/55ppm COLOR PRESS:(71ppm/71ppm)/(70ppm/70ppm)/(60ppm/60ppm)
 Product code: A0U0/A0U1/A0U2/A03U/A03V/A0E7/A0Y8/A1DU/A204/A1DV/A205

Note:

Take the same procedures, though the machine photographs are different from the ones illustrated in the procedures.

I. Accessory parts

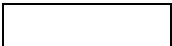
No.	Name	Shape	Q'ty
1.	LU fixing plate	 A03WIXC001SA	2
2.	TP screw M4x10		6
3.	TP screw M3x6		2
4.	Paper type label	 * Used North America only	1

II. Preparation Prior to Installation

1. Turn the machine's Sub and Main switches OFF, and unplug the power cord.
2. Do not turn the power switch ON until all the locking materials are removed from the LU.

III. Installation procedures

1. Remove all the locking tapes put on the LU.

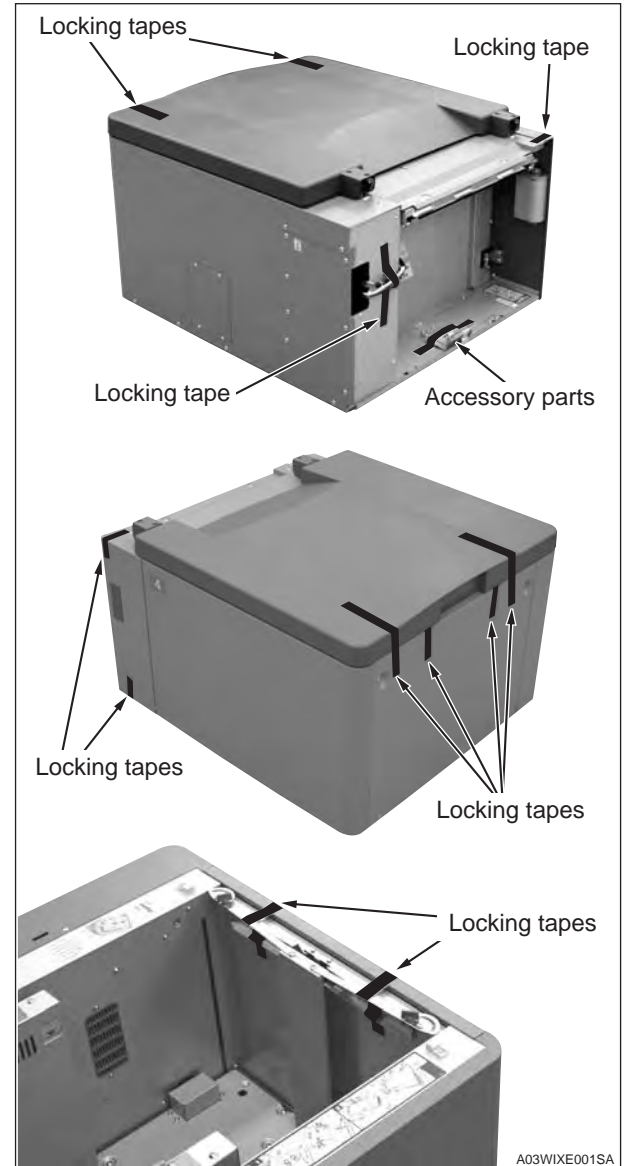

2. Attach the enclosed paper type label to the position as shown below.

Note:

Only for products bound for North America.

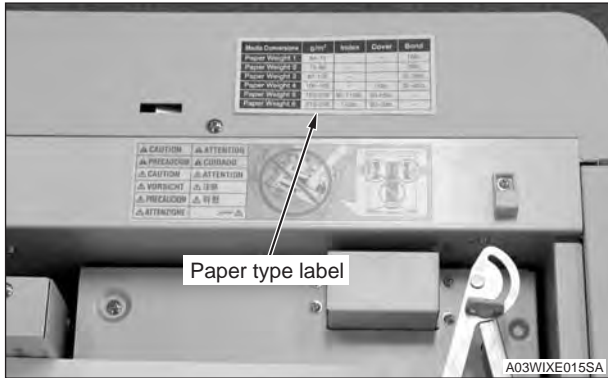

3. Open the right side door of the machine, put the LU fixing plates (2 pcs.) in the door, and close the door.

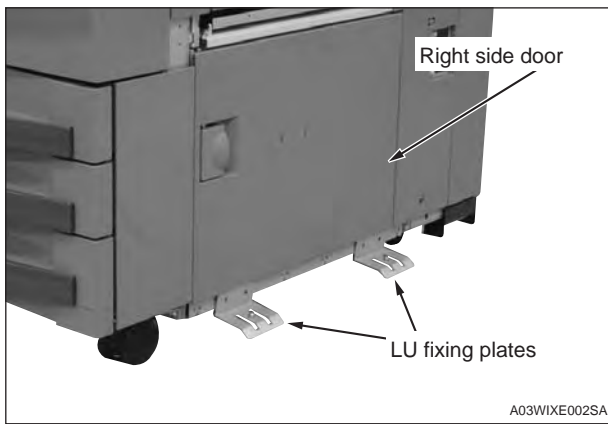

4. Secure the LU fixing plates (2 pcs.) with screws from the accessory parts (TP screw M4x10: 4 pcs.) through the front screw holes to the machine.

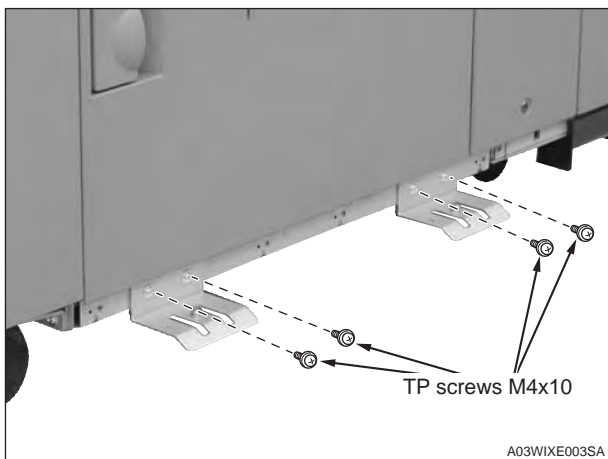

5. Remove the right cover/3. (2 screws)

Note:

Remember to remove the right cover.

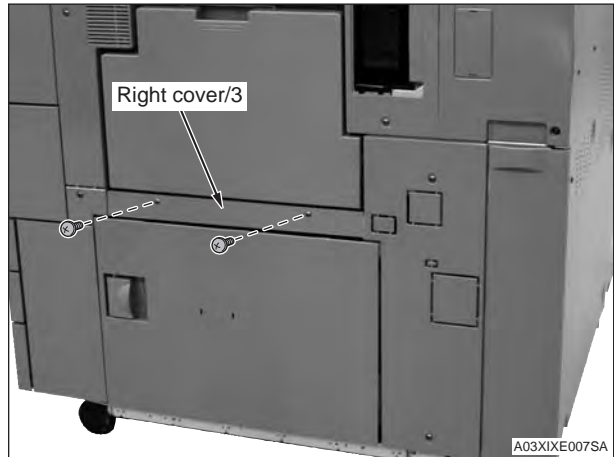

6. Cut off the split cover on the right side of the machine with a nipper.

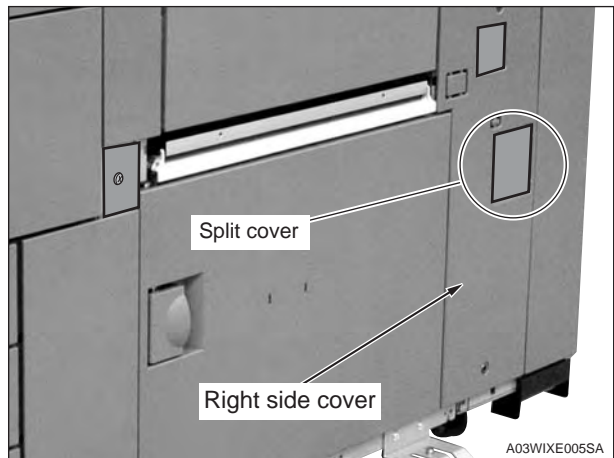

7. Pull out the connector plate. (2 screws)

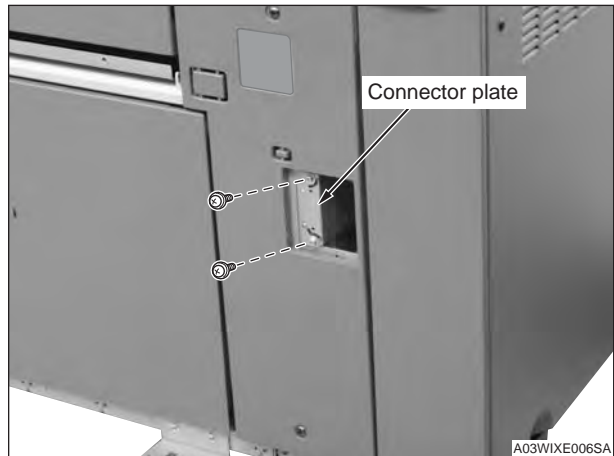

8. Connect the LU-202 connectors (3) to the machine.

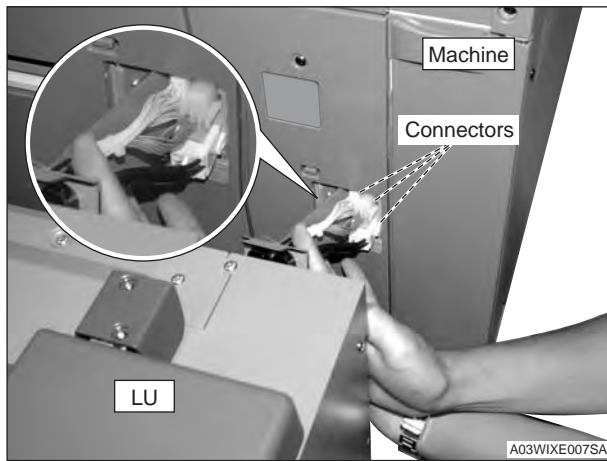

9. Fix the connector plate and wire relay bracket together. (TP screw M3x6: 2 pcs.)

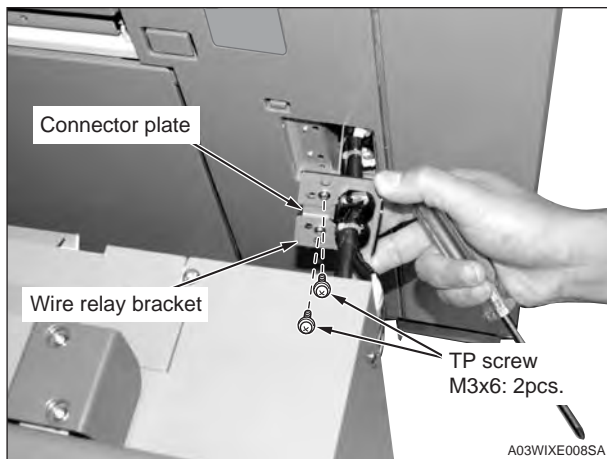

10. Install the connector plate using the 2 screws removed from the connector plate.

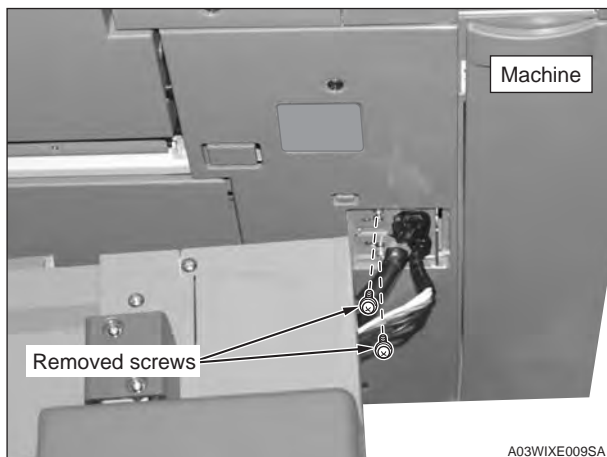

11. Open the LU front door and mount the LU on the LU fixing plates. Be sure to meet the positioning pin of LU fixing plate to the junction hole of the LU bottom plate on mounting.



12. Fix the LU to the LU fixing plate with the screws (TP screw M4x10: 2 pcs.) from the accessory parts.

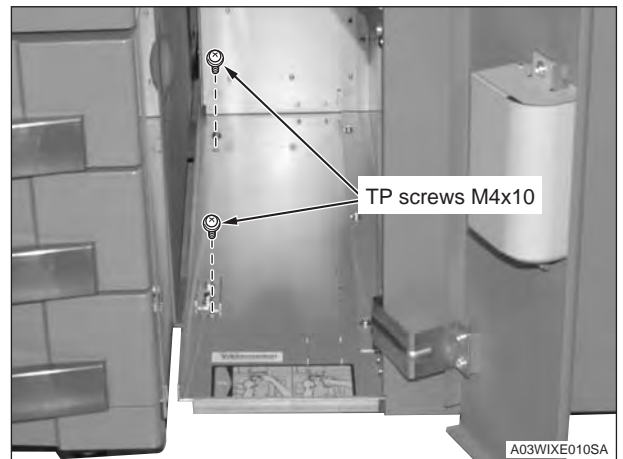

IV. Vertical opening / level adjustment

1. Adjust the height of the adjuster feet to make the vertical opening between the machine and the LU even.

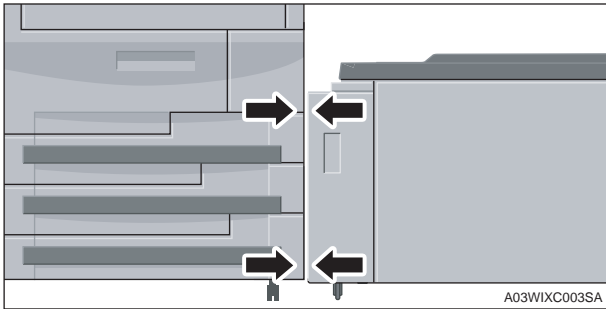

2. Open the top door of the LU, and check if the machine's paper passing area is parallel to the gap in the top door. If it's not parallel, adjust the heights of the front and rear adjuster feet.

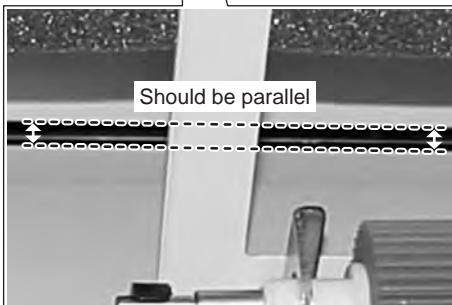
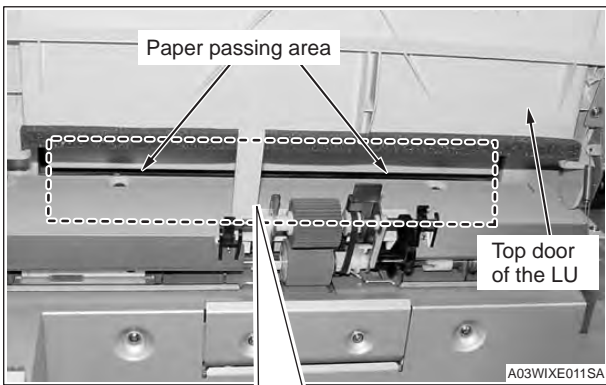

3. Adjusting directions (vertical opening/level)

Example:

If the top end of the LU is too far away, extend the LU adjuster feet to raise the LU.

- (1) Loosen the nuts (front/rear: 2 places) on the LU adjuster feet using a wrench.
- (2) Lower the up-down plate to the very bottom, and use a flathead screwdriver to extend the LU adjuster feet from inside the LU to raise it.
- (3) Adjust the front and rear adjuster feet to make the LU parallel to the direction the paper passes.

Note:

Check again the vertical opening.

- (4) When the adjustment is complete, tighten the nuts (front/back: 2 places) on the LU adjuster feet.

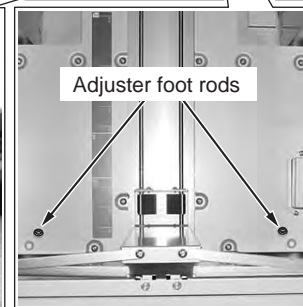
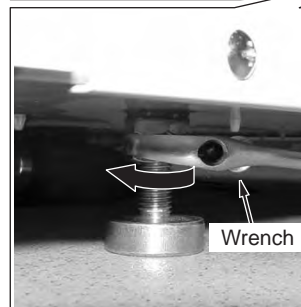
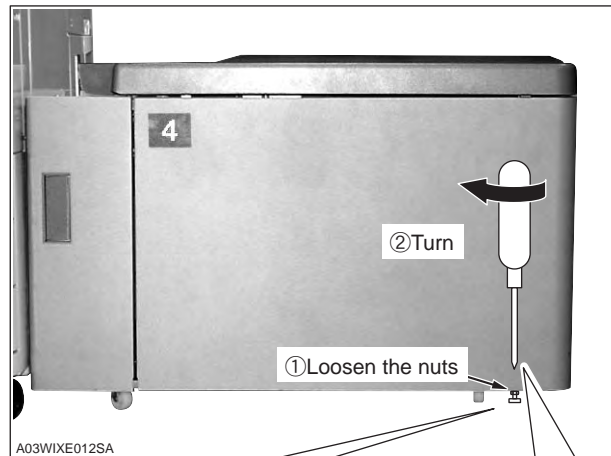

V. Paper Size Setting

1. Open the top door of the LU.
2. Loosen the knobscrews (2 pcs. each) of the paper guide side plates, adjust the plates to the size of the paper, and tighten the knobscrews.
3. Loosen the knobscrews (2 pcs.) of the end guide plate, adjust the plates to the end of the stack of paper, and tighten the knobscrews.

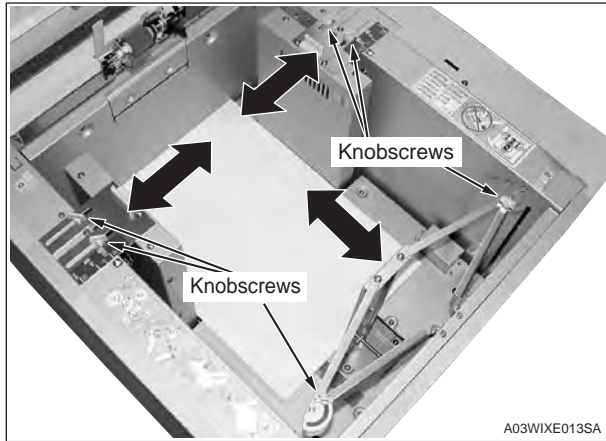

VI. Skew adjustment

Make a sample copy and if it is skewed, move the set position of the positioning pin at the LU bottom plate.

