

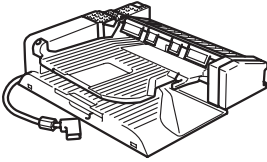

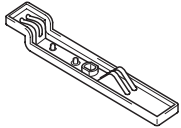
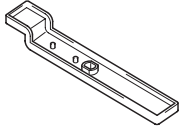
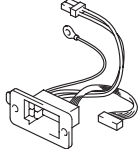

JS-505 Job Separator

INSTALLATION MANUAL

Applied Machines: C353/C253/C203
 COLOR MFP (Color/B&W): 35 ppm/35 ppm, 25 ppm/25 ppm, 20 ppm/20 ppm
 Product Code: A02E

I. Accessory parts

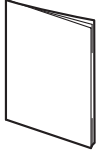
No.	Name	Shape	Q'ty
1.	Job separator	 A083IXC001DA	1
2.	Fixture A	 A083IXC002DA	1
3.	Fixture B	 A083IXC003DA	1
4.	Connector *	 A083IXC004DB	1
5.	Edge cover *	 4551IXC008DA	1
6.	Shoulder screw	 A083IXC005DA	1
7.	Screw A (4 × 18 mm)	 9J08IXC075DA	2
8.	Screw B (3 × 6 mm) *	 A090IXC001DA	3
9.	Installation manual	 4980IXC019DA	1 set

WARNING



After unpacking, be sure to get rid of the packaging materials and keep them out of the reach of children.

Putting the head in the plastic bag involves danger of suffocation.

* The connector, edge cover and screw B are not used for the machines.

II. Installation procedures

1. Turn off the machine and unplug the power cord from the power outlet.
2. Remove protective tape and shipping materials and take out accessory parts.
3. Remove the protective vinyl bag from the hookup cord.

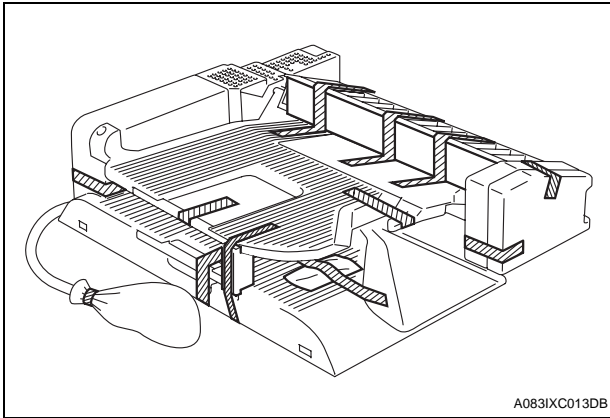

4. Remove the sub tray of the machine.
* Remove it while pushing the claws of the sub tray in the direction of the arrow ① shown on the illustration and unhook.

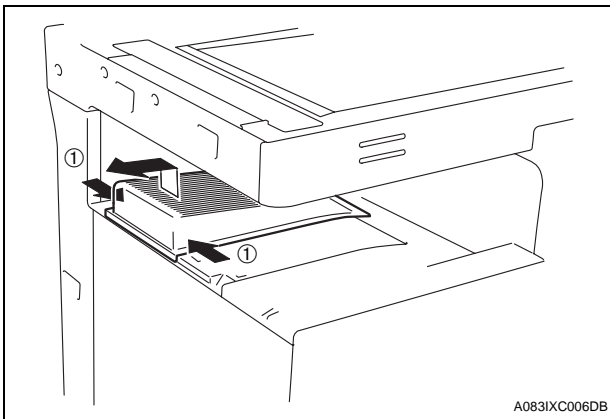

5. Peel seals off the machine (two seals).

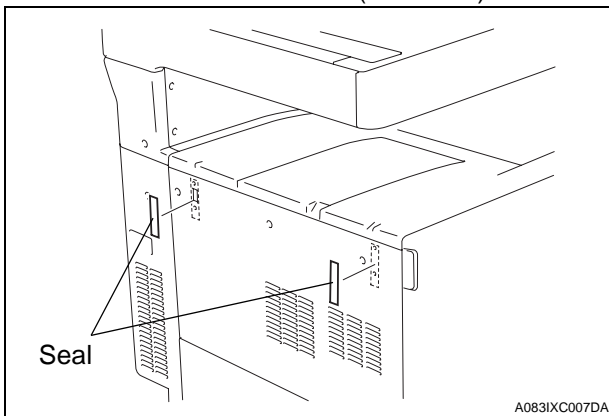

6. Use a flat-blade screwdriver and remove the cover shown in the illustration.

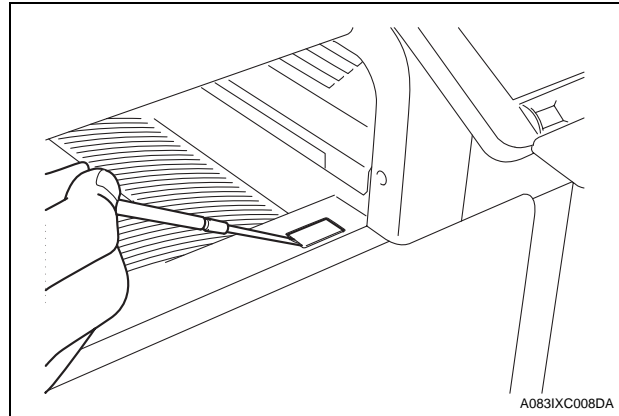

7. Fully screw down the shoulder screw furnished with the job separator.

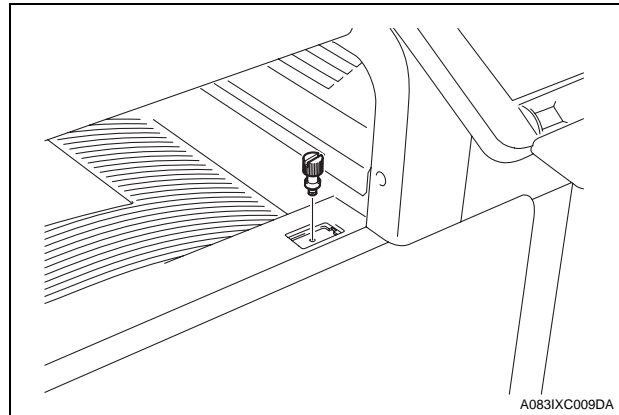

8. Install the job separator.

Note:

When installing the job separator, align the U-groove of the job separator with the shoulder screw.

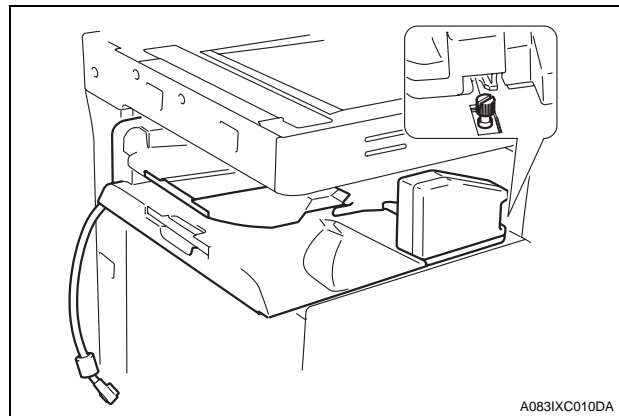

9. Secure the job separator to the machine by the fixture A (left) and fixture B (right) (one screw A furnished with the job separator for each of the fixture A and B).

Note:

- The fixture A with pieces of metal is required to be attached to the left.
- When attaching each fixture, press it downward and secure it with one screw.

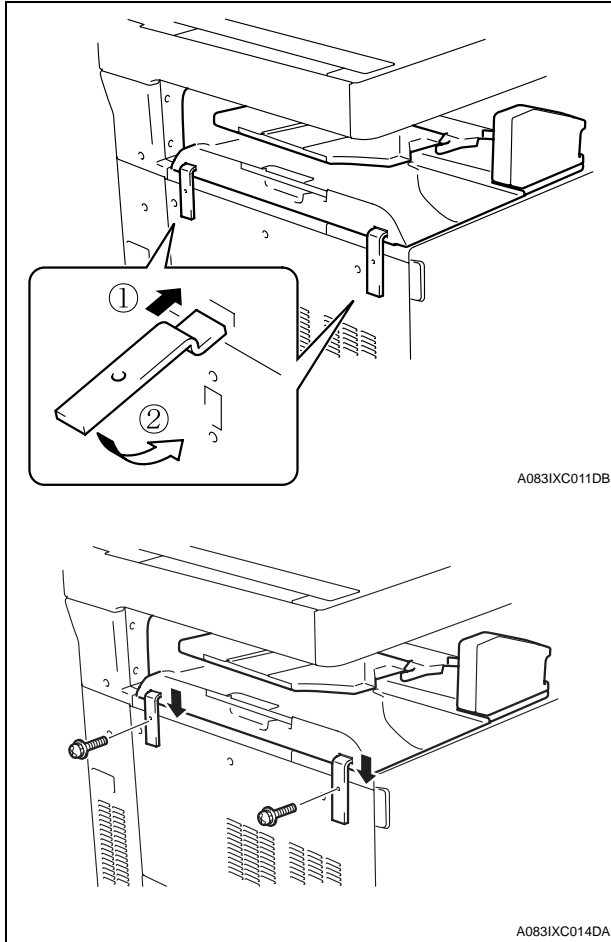

10. Connect the hookup cord to the machine.

