



DIVISIONE ELETTRONICA E SISTEMI

---

# **UAR4N**

**DIGITAL UNDER- AND OVERVOLTAGE  
MULTIFUNCTION RELAY**

**USER MANUAL**

**P500D804**

**July 2004**



## INDEX

1	GENERAL CHARACTERISTICS.....	1
2	FRONT PANEL KEYS.....	4
3	FRONT PANEL LED SIGNALLINGS.....	5
4	PROGRAMMING AND TEST.....	6
4.1	How to program the protection relay.....	6
4.2	How to modify a visualized parameter.....	7
4.3	Reset.....	7
4.4	Test of output relays.....	8
5	DISPLAY AND PROGRAMMING.....	9
5.1	Standard display.....	9
5.2	Visualization structure.....	10
5.3	ADDRESS and TIME (fig. 1).....	12
5.4	Protection function selection (fig. 1).....	14
5.5	Nominal values set-up (fig. 2).....	15
5.6	Thresholds and time delays set-up (fig. 2).....	16
5.7	Output relays programming (fig. 2).....	18
5.8	Digital inputs function programming (fig. 2).....	20
5.9	Special functions (fig. 2).....	21
5.10	Parameter values visualization (fig. 3).....	23
5.11	Events (fig. 3).....	24
5.12	Trip counters (fig.3).....	26
6	INSTALLATION.....	28
6.1	Supplied kit.....	28
6.2	Cabling.....	29
6.3	Relays R3 and R4 - Signalling / Command set-up.....	33
6.4	RS485 serial communication port.....	33
7	TIME DEPENDENT CURVES.....	34
8	TECHNICAL CHARACTERISTICS.....	35
9	TABLES.....	36

*Information printed in this manual subject to change without prior notice.*

*This manual must not be reproduced in whole or in part, in any form or by any means without the express written permission of SEB Divisione Elettronica e Sistemi.*

# 1 GENERAL CHARACTERISTICS

The protection relay UAR4N performs functions such as under and overvoltage and residual overvoltage relay; the user can select one of the functions listed in the table below.

Functions	ANSI	Measured voltages
Undervoltage (2 or 3-phase)	27	U1, U2, U3
Overvoltage (2 or 3-phase)	59	
Under and overvoltage (2 or 3-phase)	27 59	
Residual overvoltage	59N 59Vo	Uo
Stator earth fault 95% (residual voltage)	64 S	
Under and overvoltage (2 or 3-phase) + residual overvoltage	27 59 59N	U1, U2, U3, Uo
Under and overvoltage (2 or 3-phase) + stator earth fault 95% (residual voltage)	27 59 64S	U1, U2, U3, Uo
Voltage unbalance	60	U1, U2, U3

All the set-up and measured parameters can be viewed on the front panel display and transmitted on the RS485 communication serial port.

**THRESHOLDS** - the following thresholds are available:

- undervoltage thresholds            U<,    U<<
- overvoltage thresholds            U>,    U>>
- residual overvoltage                Uo>,    Uo>>

The available settings for each threshold are listed in Table A.

Related to each threshold, partial and total counters of TRIP conditions are available.

**TRIP DELAYS** - a programmable time delay (TI) is available for each threshold; it can be programmed as definite time or dependent time in compliance with IEC 255-4 standard.

For each threshold programmed as definite time, an additional programmable time delay (TA) is available; the additional time delay is added to time delay TI. The additional time delay activation is controlled by the digital inputs to allow the use of the UAR4N relay with co-operating protection relays.

The available settings for each timers are listed in Table A.

**OUTPUT RELAYS** - the UAR4N controls 4 output relays (named R1, R2, R3 and R4); these relays can be programmed to be activated on START or TRIP conditions of one or more thresholds.

START	instantaneous activation of the output relay when at least one of the measured voltages exceeds the programmed threshold value
TRIP	activation of the output relay when the programmed time delay (TI or TI+TA) related to a threshold expires.

The quiescent state of each single relay R1, R2, R3 and R4 can be programmed as normally energized (ON) or normally de-energized (OFF).

An additional relay R5 (normally energized) is controlled by the self-diagnosis routines to report detected fault conditions.

**DIGITAL INPUTS** - there are available 3 digital inputs to activate the following functions (when enabled by the programmed set-up):

- additional time delay (related to one or more thresholds)
- on/off thresholds
- STATUS function (recording of measures on external event)
- pilot wire fault monitoring

For each digital input can be programmed the condition that activates the related functions:

HI voltage =	> 20 V dc / ac
LO voltage =	0 ÷ 10 V dc / ac

The digital input acquisition is valid when the voltage value stays in the range HI or LO for at least 40 ms.

**DISPLAY OF MEASURES** - the user can select the continuous display of a measured voltage (primary values); all the voltage measures can be transmitted to an external controller through the RS485 port.

**EVENTS** - information related to the last 8 events (TRIP or STATUS) are recorded in the EEPROM memory.

Information includes the threshold set-up and activated relays (TRIP event only), the measured voltages, the digital input status, date and time of the event.

**SELF-DIAGNOSIS** - the software includes a non stop monitoring module that controls the functionality of all hardware and software resources of the protection relay.

Detected fault conditions are reported by:

- diagnostic message on the display
- glow of a red LED on front panel
- R5 output relay drop-off

The fault condition signalling stays until faults are pointed out by the monitoring module; during this condition the protection functions are suspended to avoid unsuitable tripping.

**STATUS FUNCTION** - when the STATUS function is activated by one of the digital input (when programmed) the protection relay memorizes information related to measured voltages and digital input status (see par. 5.11 - EVENTS). The recorded information allows an analysis of trip causes in co-operative protection relays systems.

**PILOT WIRE FAULT MONITORING** - when the function is programmed, the digital input DIG2 is used to control the correct functionality of the pilot wire. Digital input DIG2 is always expected to be complementary of DIG1 input (HI-LO or LO-HI) to identify faults on pilot wire.

The fault condition is reported as detected by the self-diagnosis module but the protection functions are not suspended; only the functions related to DIG1 digital input are suspended as the DIG1 status cannot be longer considered as true.

The fault condition is reported when DIG1 and DIG2 signals are not complementary for more then 100 ms.

**REMOTE COMMUNICATION** - the opto-insulated serial port RS485 can communicate with a personal computer or a remote control and monitoring system equipped with an RS485 interface or with a standard RS485/RS232 converter.

It is possible to select the communication standard between STANDARD (ASCII 7 bit - Seb protocol) or MODBUS (ASCII mode, SLAVE).

All the set-up and measured parameters can be transmitted on the RS485 communication serial port; when communication is active (LED REMOTE glows), the operator on front panel can view the relay set-up but changes of parameters are disabled (ENTER and  buttons disabled).

**SPECIAL FUNCTIONS** - the following special functions can be activated by the operator on the measured phase voltages (special functions do not act on the residual voltage):

- trip inhibition when all measured line voltages are lower than  $0,2 U_n$
- relay trip enable or relay trip inhibition when:
  - all the measured voltages are lower than  $U_<$  and  $U_{<<}$  thresholds
  - all the measured voltages are higher than  $U_>$  and  $U_{>>}$  thresholds

## 2 FRONT PANEL KEYS

The 5 push-buttons on the front panel allow to view all the protection parameters and to modify the protection set-up.



right arrow



down arrow



programming session activation or parameter confirmation



change or increment of the selected parameter



reset of the protection relay (rif. Par. 4.3)

### VISUALIZATION OF PARAMETERS

- all visualizations are circular and they can be displayed using the two arrow push-buttons.
- the structure of the visualizations and their contents are showed in Figures 1, 2 and 3.
- when the sealable transparent front panel is installed only the arrow push-buttons and the RESET push-button are accessible to prevent unauthorized modification of the protection set-up.

### MODIFICATION OF PARAMETERS

- remove the transparent sealable front panel to access ENTER and  push-buttons.

### 3 FRONT PANEL LED SIGNALLINGS

POWER (green)	⊕ auxiliary supply available
FAIL (red)	⊕ fault condition detected by SELF-DIAGNOSIS software or by PILOT WIRE FAULT MONITORING function.
REMOTE (red)	⊕ communication session active on RS485 port
U< - << (red)	⊕ trip condition on U< or U<< thresholds
U> - >> (red)	⊕ trip condition on U> or U>> thresholds
Uo (red)	⊕ trip condition on Uo> or Uo>> thresholds

The last trip condition (threshold indication) is also showed on front panel display; more information on trip condition are presented in the recorded EVENT (see par. 5.11).

**NOTE** - even when only the ANSI 27 function is activated (undervoltage thresholds) an internal 2 Un overvoltage threshold is always active therefore if a mistake on the protection relay insertion is made (100 V protection signal input terminals connected to one or more plant VT's with more than 200 V nominal output) the red LED related to U> threshold will lit, without any trip of output relays.

When the ANSI 59 function is activated (overvoltage thresholds) the trip of the protection relay will show the mistake.



## 4 PROGRAMMING AND TEST

The protection relay is easily programmable following the instructions in the next paragraphs:

- HOW TO PROGRAM THE PROTECTION RELAY
- HOW TO MODIFY A VISUALIZED PARAMETER

All parameters can be freely modified; the proper protection set-up as required by the plant management is submitted to the operator's judgement.

### 4.1 How to program the protection relay

The programmable parameters are showed in Figures 1, 2 and 3 at the following references:

B2÷B7	relay address (RS485) and date/time
C1	relay function
D1÷D6	nominal values, contrast etc
E1÷E5	thresholds and time delays
F1÷F7	output relays functions
G1÷G3	digital input functions
H1÷H3	special functions
R1÷R12	partial trip counters reset

The programming sequence is the following:

1. **SELECT** the visualization (on display) of the parameter to be modified using the arrow push-buttons
2. **ACTIVATE** the PARAMETER MODIFICATION session depressing the [ENTER] push-button and modify the parameter value
3. **END** the parameter modification session depressing again the [ENTER] push-button
4. **REPEAT** the procedure from 1) to 3) for all the parameters required to obtain the new protection relay set-up
5. **CONFIRM** the new protection relay set-up at the visualization CONFIRM PROG? (Fig. 2, ref. J1) within 5 minutes depressing the push-buttons [ENTER] and  up to visualize **YES** and [ENTER] again to confirm.

NOTE: The protection relay continues to operate using the previous set-up until the new set-up is confirmed as at point 5) above; the visualization of the modified parameters before the new set-up confirmation is only temporary to allow an easy definition of the new protection set-up.

If the new set-up is not confirmed within 5 minutes from the last pressed push-button, the protection relay visualizes again the previous set-up (the parameters set-up that the protection relay is still using).

## 4.2 How to modify a visualized parameter

When the parameter to be modified is visualized on front panel display do the following sequence:

### 1. PRESS [ENTER] to activate the parameter modification session

If one or more parameters are modifiable, on the first of them will appear a blinking cursor.

If no parameters are modifiable, no blinking cursor will appear.

### 2. MODIFY THE PARAMETER pressing the arrow push-buttons and



when two parameters are modifiable, the push-button allows to point-out the parameter to be modified (the selected parameter will blink)



when numerical parameters are pointed-out the push-button allows to select the digit to be modified



increasing of the parameter

- a) the digits are increased by 1 unit
- b) the other parameters are presented following the selection list

### 3. PRESS [ENTER] to end parameter modification session

The modification session is ended and the parameter stops to blink

NOTE: if a numerical parameter is selected out of the accepted range (as shown in Table A) when the push-button [ENTER] is pressed for few seconds an error message will be displayed as:

Data
Error

and the parameter will be displayed again with the former value.

## 4.3 Reset

When the push-button [RESET] is pressed, the protection relays returns to the standard condition:

- reset of glowing LEDs
- drop-off of tripped relays
- reset of any parameter changed but not confirmed (parameters are shown as confirmed at the end of the last programming session)

- display on STANDARD MODE (Fig. 1, ref. A1 - par. 5.1)

#### 4.4 Test of output relays

When the output relays test is selected (Fig. 2, ref. F8) it is possible to command an output relay (one at the time) to trip from the current status allowing functional tests on electrical plants.

The output relays are activated with the following sequence:

1. **SELECT THE VISUALIZATION** of the desired output relay to be tested

TEST R1
OFF

2. **PRESS [ENTER]** to activate the test session; the message OFF will start to blink.
3. **PRESS**  and the message on the display will change as:

TEST R1
ON

4. **PRESS [ENTER]** to command the instantaneous trip of the output relay (change of the current status).

The relay will stay on the new condition until:

- the  or [RESET] push-button is pressed
- the [ENTER] push-button is pressed and the sequence at points 3 and 4 is repeated (presenting OFF condition)

The same procedure will be used for R2, R3 and R4 relays.

## 5 DISPLAY AND PROGRAMMING

The contents and the structure of the displayed messages are shown in figures 1, 2 and 3; the references A1, B1, B2 etc. identify specific displayed messages in the figures.

### 5.1 Standard display

#### A1 - STANDARD DISPLAY

It is the standard displayed message without operator's intervention (no push-buttons pressed for at least 5 minutes) or when the RESET push-button has been pressed.

The displayed information is function of the protection relay status.

#### NORMAL FUNCTIONING

During this state the following information can be visualized (as defined by set-up):

- **Protection function (ANSI code)** - the display shows the ANSI codes of the selected functions (ref. C1 - FUNCTION SELECTION).
- **Measured voltage** - the display shows one of the measured voltages; the voltage to be visualized is selected by operator (ref. D4).

The voltage is visualized as primary value; if the selection of the voltage to be visualized refers to a voltage not measured (depending on FUNCTION SELECTION) no values are presented.

#### ON TRIP CONDITION

When a trip condition occurs the protection relay visualizes the TRIP message that includes the threshold related to the trip; the displayed messages are as the following:

TRIP U>	TRIP Uo>>	TRIP U<<	TRIP Uo>
------------	--------------	-------------	-------------

The information of the trip, as well the glowing of the related LEDs, is displayed until the [RESET] push-button is pressed.

If a new trip condition occurs, the displayed information will be updated; information related to previous trips are recorded in EVENTS memory.

#### FAULT CONDITION

When a permanent or temporary fault condition is detected by the self-diagnosis module, the following message is displayed:

FAIL eeeeeeee
------------------

The string eeeeeeee can be:

PILOT            Detected fault condition on pilot wire; the function related to DIG1 digital input is suspended  
**Corrective action** - verify pilot wire (short or open circuit)

**HARDWARE** Detected fault condition on hardware or software resources of the protection relay; all functions are suspended.  
**Corrective action** - replace the protection relay and contact SEB post sales service.

### 5.2 Visualization structure

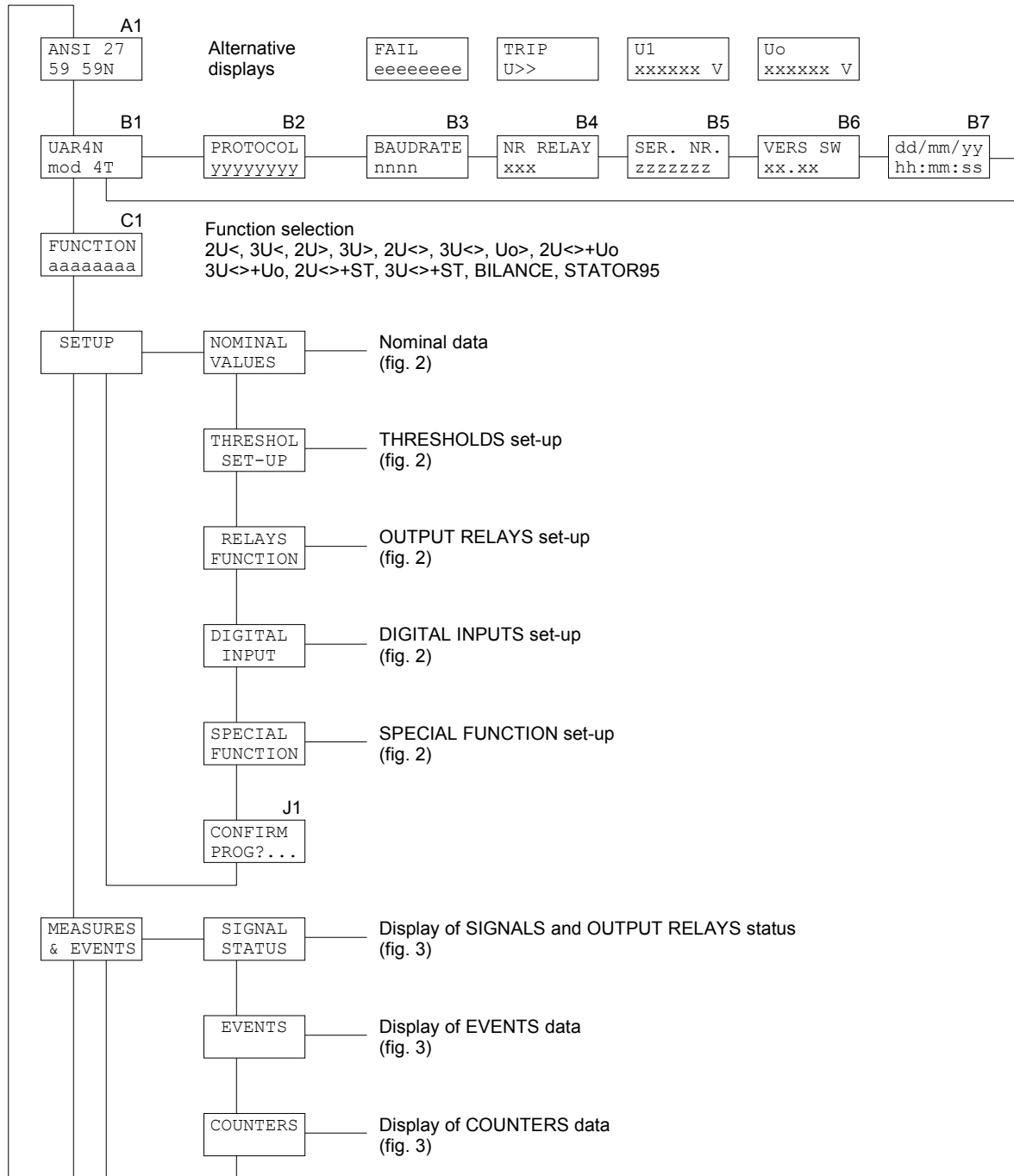
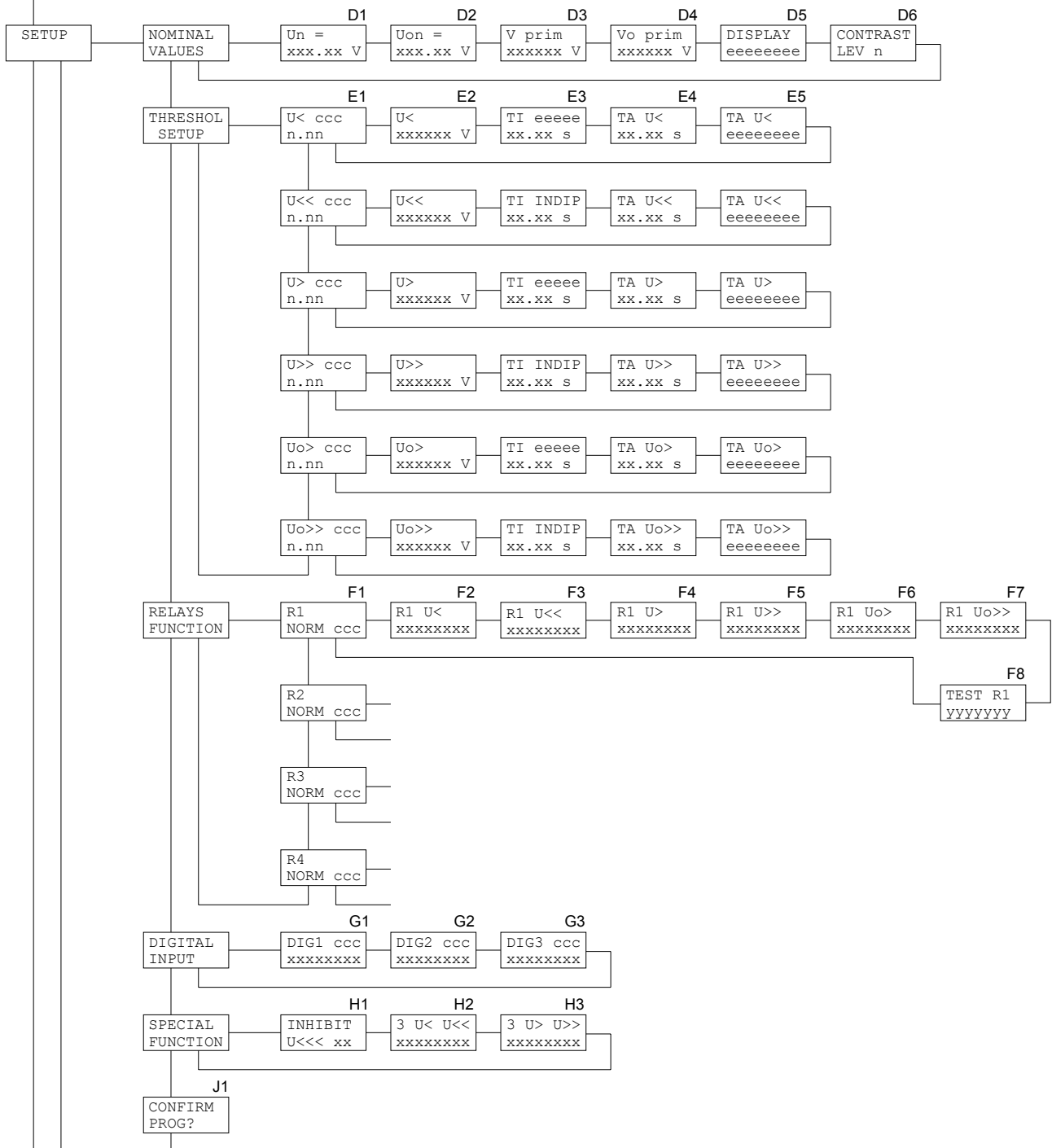

Figure 1

From FIGURE 1



To FIGURE 3

Figure 2

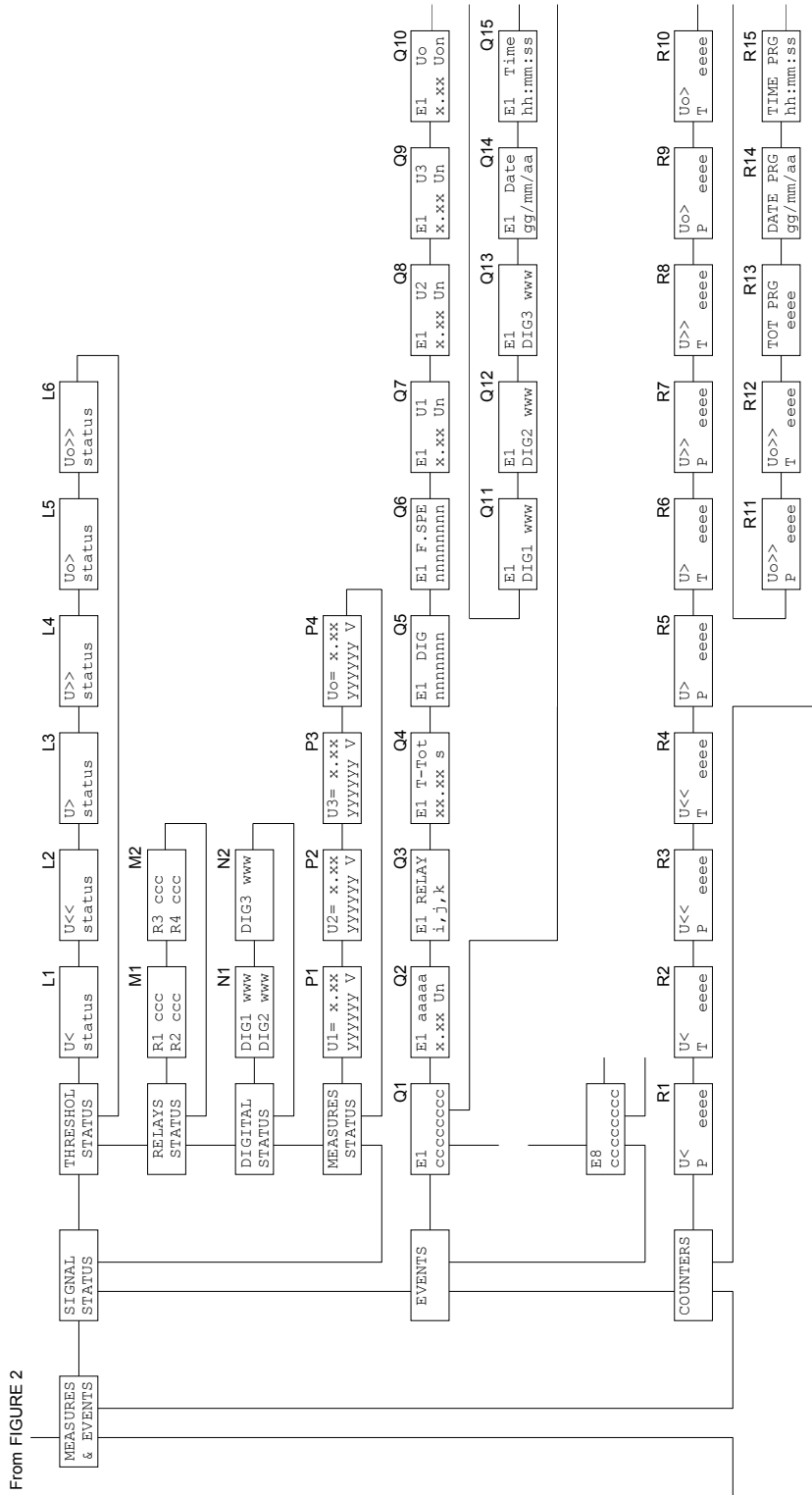

Figure 3

### 5.3 ADDRESS and TIME (fig. 1)

#### B1 - RELAY MODEL (not programmable)

UAR4N  
mod. 4T

The nominal input voltages are programmable (ref. D1 and D2 - par. 5.5).

**B2 - COMMUNICATION PROTOCOL (programmable)****B2**

PROTOCOL
xxxxxxxx

The communication protocol is programmable between the followings:

STANDARD	ASCII SEB protocol
MODBUS	Modbus protocol (SLAVE)

When the MODBUS protocol is selected the following display is showed to allow the selection of the transmission speed:

**B3**

BAUDRATE
xxxx

The xxxx parameter is selectable between the followings:

**300 - 600 - 1200 - 2400 - 4800 - 9600**

When the STANDARD protocol is selected the baud rate is automatically selected by the protection relay.

**B4 - ADDRESS (programmable)**

NR RELAY
001

Programmable address from 001 to 255.

The number is used on RS485 port to address a specific relay when two or more protection relays are linked on the same serial line.

**B5 - RELAY SERIAL NUMBER (not programmable)**

SER. NR
0012345

**B6 - SOFTWARE REVISION LEVEL (not programmable)**

SW REV
zz.zz

**B7 - TIME/DATE (programmable)**

dd/mm/yy
hh:mm:ss

Time and date are programmable and they are used to mark recorded events.



NOTE: the clock is not provided with back-up battery, therefore a loss of auxiliary supply will force time/date to the following condition:

01/01/90
00:00:00

## 5.4 Protection function selection (fig. 1)

### C1 - FUNCTION SELECTION (programmable)

FUNCTION
xxxxxxxx

The selection of the active function defines the selectable thresholds.

FUNCTION	ANSI	SELECTION	ACTIVABLE THRESHOLDS
Undervoltage 2-phase Undervoltage 3-phase	27 27	<b>2 U&lt;</b> <b>3 U &lt;</b>	U<, U<<
Overvoltage 2-phase Overvoltage 3-phase	59 59	<b>2 U&gt;</b> <b>3 U&gt;</b>	U>, U>>
Under- overvoltage 2-phase Under- overvoltage 3-phase	27 - 59 27 - 59	<b>2 U&lt;&gt;</b> <b>3 U &lt;&gt;</b>	U<, U<< U>, U>>
Residual overvoltage	59N 59Vo	<b>Uo&gt;</b>	Uo>, Uo>>
Under- overvoltage 2-phase and residual overvoltage	27 59 59N	<b>2U&lt;&gt; + Uo&gt;</b>	U< U<< U> U>> Uo> Uo>>
Under- overvoltage 3-phase and residual overvoltage	27 59 59N	<b>3U&lt;&gt; + Uo&gt;</b>	U< U<< U> U>> Uo> Uo>>
Under- overvoltage 2-phase and stator 95% earth fault	27 59 64S	<b>2U&lt;&gt; + ST</b>	U< U<< U> U>> Uo> Uo>>
Under- overvoltage 3-phase and stator 95% earth fault	27 59 64S	<b>3U&lt;&gt; + ST</b>	U< U<< U> U>> Uo> Uo>>
Voltage balance	60	<b>BALANCE</b>	U> U>>
Stator earth fault 95%	64S	<b>STATOR95</b>	Uo> Uo>>

NOTE: if only the ANSI 27 function is activated (undervoltage thresholds) and a mistake on the protection relay insertion is made (100 V protection signal input terminals connected to one or more plant VT's with more than 200 V nominal output) the red LED related to U> threshold will lit, without any trip of output relays.

When the ANSI 59 function is activated (overvoltage thresholds) the trip of the protection relay will show the mistake.

Examples:

FUNCTION
3 U>

FUNCTION
2U<>+Uo>

FUNCTION
BALANCE

## 5.5 Nominal values set-up (fig. 2)

### D1 - NOMINAL LINE VOLTAGE SELECTION - $U_n$ (programmable)

$U_n =$ xxx.xx V
---------------------

**$U_n$ :** nominal line voltage selection (nominal secondary voltage of plant VTs) selectable between the followings:

**57.73 - 63.50 - 72.16 - 100 - 110 - 125 - 190 - 220 - 230 - 380 - 400**

The  **$U_n$  selection is not visualized** when the selection of the function of the protection relay includes only residual voltage measurement (see selection table par. 5.4 - C1).

### D2 - NOMINAL RESIDUAL VOLTAGE SELECTION - $U_{on}$ (programmable)

$U_{on} =$ xxx.xx V
------------------------

**$U_{on}$ :** nominal residual voltage selection (nominal secondary voltage of plant residual voltage transformers) selectable between the followings:

**57.73 - 63.50 - 72.16 - 100 - 110 - 125 - 190 - 220 - 230 - 380 - 400**

The  **$U_{on}$  selection is not visualized** when the selection of the function of the protection relay includes only line voltage measurement (see selection table par. 5.4 - C1).

### D3 - PRIMARY VT's LINE VOLTAGE (programmable)

$V_{prim}$ xxxxxx V
------------------------

Primary voltage value of the installed line VT's; the value is programmable from 000001 to 999999 V.

### D4 - PRIMARY VT's RESIDUAL VOLTAGE (programmable)

$V_{o prim}$ xxxxxx V
--------------------------

Primary voltage value of the installed residual voltage VT; the value is programmable from 000001 to 999999 V.

### D5 - STANDARD DISPLAY SELECTION (programmable)

DISPLAY eeeeeeee
---------------------

It allows to select the standard displayed information (ref. A1) when no trip condition occurs and no fault condition have been detected by the self-diagnosis module; the available selections are the following:

ANSI	displays of ANSI code
U1	displays measured voltage U1
U2	displays measured voltage U2
U3	displays measured voltage U3
Uo	displays measured residual voltage Uo

The voltages can be line-to-line or line-to-neutral depending on VT's or relay insertion.

The list of the selectable voltages depends on the programmed FUNCTION SELECTION (ref. C1); the voltage is displayed in primary values (the value depends on D3 and D4 set-ups).

Selection examples:

DISPLAY ANSI	DISPLAY U1	DISPLAY Uo
-----------------	---------------	---------------

#### D6 - DISPLAY CONTRAST LEVEL (programmable)

CONTRAST LEV x
-------------------

The display contrast level is programmable from 0 to 9.

The backlighted display is switched off if no push-button is pressed for at least 5 minutes; when one of the front panel push- button is pressed the display is switched on.

### 5.6 Thresholds and time delays set-up (fig. 2)

In the programming session are displayed only the thresholds available depending on FUNCTION SELECTION set-up (ref. C1, paragraph 5.4).

The information and set-ups related to threshold U< in the following points (references E1÷E5) are effective for all the thresholds U<<, U>, U>>, Uo>, Uo>> just taking into consideration the change of the threshold identification (with limits as presented in table A).

#### E1 - THRESHOLD LEVEL SET-UP (programmable)

U<   ccc
n.nn

U<	threshold identification (U<<, U>, U>>, Uo>, Uo>>)
ccc	ON - enabled threshold OFF - disabled threshold (available but not active)
n.nn	threshold level expressed in terms of relative values Un (threshold U<, U<<, U>, U>> ) Uon (threshold Uo>, Uo>>)

Examples:

U< ON
0.50

U>> OFF
1.50

Uo>> ON
1.00

## E2 - THRESHOLD LEVEL IN PRIMARY VALUES (not programmable)

U<
xxxxxxx V

The programmed threshold (ref. E1) is shown in terms of primary voltage; the value depends on the programmed VT's primary values (ref. D3 and D4 – paragraph 5.5).

**U<** threshold identification (U<, U<<, U>, U>>, Uo>, Uo>>)

**xxxxxx** threshold level expressed in Volts (primary values)

## E3 - TIME DELAY SET-UP (programmable)

TI eeeee
xx.xx s

Set-up of time-delay to the activation (TRIP) of the programmed output relays when the measured voltage exceeds the threshold level.

**Parameter TI eeeee:** time delay characteristic

For U<, U> and Uo> thresholds the time delay can be selected between one of the following:

INDIP	independent time delay
DIP=A	time delay as curve A IEC 255-4 (inverse time)
DIP=B	time delay as curve B IEC 255-4 (very inverse time)
DIP=C	time delay as curve C IEC 255-4 (extremely inverse time)

For the remaining thresholds the TI parameter is fixed as INDIP (independent time).

**Parameter xx.xx:**

Time independent - time delay (seconds) to activate the programmed output relays: the output relay trips when the measured voltage exceeds the threshold level for at least xx.xx seconds (programmable from 00.02 to 99.99 s).

Time dependent - value of the parameter K (see formulas paragraph 7).

TI DIP=B
02.50 K

TI DIP=A
10.00 K

TI INDIP
03.25 s

NOTE: the index K or s is shown coherently to the selected time-delay characteristic when the push-button [ENTER] is pressed.

#### E4 - ADDITIONAL TIME DELAY SET-UP (programmable)

The selection is displayed only when a TIME INDEPENDENT characteristic has been selected (TI INDIP at ref. E3); when TIME DEPENDENT characteristic has been programmed, the selection will not be displayed.

TA U<
xx.xx s

The additional time delay TA is programmable from 00.00 to 99.99 seconds; please note that at least one of the digital inputs should be programmed to activate time delay function (ref. G1, G2, G3 - paragraph 5.8).

The additional time delay TA is added to the time delay TI to obtain the output relay trip when the TI+TA time expires.

The additional time delay TA will be added if the time delay TI is programmed at least equals to 50 ms (digital input acquisition time - 40 ms).

#### E5 - DIGITAL INPUT ACTIVE ON THRESHOLD (not programmable)

TA U>
eeeeeeee

It shows the digital input programmed to activate the additional time delay TA on the displayed threshold.

The parameter **eeeeeeee** can show one of the following values:

DISABLED	none of the digital inputs has been programmed to activate an additional time delay related to threshold U>
DIG1	digital input DIG1 activates the TA delay on threshold U>
DIG2	digital input DIG2 activates the TA delay on threshold U>
DIG3	digital input DIG3 activates the TA delay on threshold U>

More than one digital input can activate the same additional time delay (e.g. DIG 1,3).

Please note that to activate the additional time delay at least one of the digital inputs should be programmed (ref. G1, G2, G3 - paragraph 5.8).

When a TIME DEPENDENT characteristic threshold has been programmed the visualization is omitted as no additional time delays can be defined and programmed on time dependent delays.

### 5.7 Output relays programming (fig. 2)

The session allows to program the activation of the output relays R1, R2, R3 or R4 on START or TRIP conditions for each threshold.

In the programming session are displayed only the thresholds available depending on FUNCTION SELECTION set-up (ref. C1 - paragraph 5.4).

Equivalent information and set-up related to relay R1 is available for the relays R2, R3 and R4 just changing the relay identification.

### F1 - OUTPUT RELAY R1 QUIESCENT STATUS (programmable)

```
R1
NORM xxx
```

Programming of the R1 relay status when no START or TRIP conditions are activated (none of the measured voltages exceed their thresholds).

NORM OFF: normally de-energized (energized status on activation)

NORM ON: normally energized (de-energized status on activation)

### F2 - OUTPUT RELAY R1 ACTIVATION ON THRESHOLD U< STATUS (programmable)

```
R1 U<
xxxxxx
```

Programming of the R1 output relay activation (START/TRIP/NONE) when one of the line voltages is below the programmed threshold U<.

The parameter **xxxxxx** is selectable as the following:

- |       |  |
|-------|--|
| START | instantaneous output relay R1 activation when one of the measured line voltage is below the programmed threshold U<                          |
| TRIP  | output relay R1 activation when one of the measured line voltage is below the programmed threshold level U< for at least TI or TI+TA seconds |
| NONE  | no activation related to threshold U<  |

### F3 ÷ F7 - OUTPUT RELAY ACTIVATION ON THRESHOLD U<<, U>, U>>, Uo> and Uo>> STATUS (programmable)

Example:

```
R1 U>>
xxxxxx
```

```
R1 U<<
xxxxxx
```

```
R1 Uo>
xxxxxx
```

Programming of the output relay activation (STAR/TRIP/NONE) when one of the measured line voltages is below the thresholds U<< or exceeds the threshold U> or U>> and when the measured residual voltage exceeds the threshold Uo> or Uo>>.

### F8 - TEST OF OUTPUT RELAY R1

```
TEST R1
xxxxxxxx
```

See paragraph 4.4

## 5.8 Digital inputs function programming (fig. 2)

For each digital input one of the following functions are selectable:

- additional time delay (related to one or more thresholds)
- ON / OFF threshold
- STATUS function (recording of measures on external command)
- pilot wire fault monitoring (only DIG2 monitors DIG1).

When function a) is programmed, a message is displayed at ref. E5, par. 5.6.

When the function of more than one digital input refers to the same threshold, the priority will be the following:

- OF selection (threshold disabled) has the priority on TA function (additional time delay)
- the ALL selection (ALL the thresholds) has the priority on single threshold selection.

### G1 - DIGITAL INPUT DIG1 SET-UP (programmable)

DIG1	cc
xxxxxxx	

Programming of the function related to digital input channel 1 (DIG1).

**Parameter cc:** programming of the condition that activates the function related to digital input DIG1; the condition is selectable between HI and LO.

**Parameter xxxxxx:** programming of the function related to digital input DIG1; the following functions are selectable:

NONE	no functions active related to digital input DIG1
TA U<	additional time delay on threshold U<
TA U<<	additional time delay on threshold U<<
TA U>	additional time delay on threshold U>
TA U>>	additional time delay on threshold U>>
TA Uo>	additional time delay on threshold Uo>
TA Uo>>	additional time delay on threshold Uo>>
TA ALL	additional time delay on all thresholds
OF U<	threshold U< disabled
OF U<<	threshold U<< disabled
OF U>	threshold U> disabled
OF U>>	threshold U>> disabled
OF Uo>	threshold Uo> disabled
OF Uo>>	threshold Uo>> disabled
OF ALL	all thresholds disabled
STATUS	activation of status function (see paragraph 1.)

**G2 - DIGITAL INPUT DIG2 SET-UP (programmable)**

DIG2	cc
xxxxxxxx	

Programming of the function related to digital input channel 2 (DIG2); the selections available are the same as presented for DIG1 (ref. G1) plus the following:

MONITOR                      activation of pilot wire monitor function.

**G3 - DIGITAL INPUT DIG3 SET-UP (programmable)**

DIG3	cc
xxxxxxxx	

Programming of the function related to digital input channel 3 (DIG3); the selections available are the same as presented for DIG1 (ref. G1).

**5.9 Special functions (fig. 2)**

The special functions can be activated on under- and overvoltage thresholds (**U<**, **U<<**, **U>**, **U>>**) related to the line measured voltages (U1, U2 and U3); the special functions cannot be activated on residual voltage thresholds (**Uo>** and **Uo>>**).

When the selected function of the protection relay includes only line voltage measurement (see selection table par. 5.4 - C1) the set-ups related to special function are not shown.

**H1 - TRIP INHIBITION WHEN ALL MEASURED VOLTAGES ARE LOWER THAN 0,2 Un (programmable)**

INHIBIT
U<<< xxx

Programming of TRIP inhibition of the protection relay when **ALL THE MEASURED LINE VOLTAGES** are lower than 0,2 Un (voltage absence TRIP inhibition).

The parameter **xxx** can selected between the following:

- |     |  |
|-----|--|
| OFF | disabled function - the protection relay operates normally and when undervoltage thresholds are activated the protection relay TRIPs when one or more of the measured line voltages are below the programmed thresholds ( <b>U&lt;</b> and/or <b>U&lt;&lt;</b> ) |
| ON  | enabled function - the protection relay does NOT TRIP on activated undervoltage thresholds when ALL the measured line voltages are below the 0,2 Un value.   |

**NOTE** - when activated the INHIBIT **U<<<** function please take into consideration the following:



- a) if one or more output relays are programmed to trip on START condition of **U<** and **U<<** thresholds (for threshold set-up ref. F2 and F3), these relays will trip as the START condition is detected and activated without any delays.
- b) the time delays on the TRIP conditions related to thresholds **U<** and **U<<** should be programmed at least 60 ms (0,06 s) to avoid inopportune trips of the output relays related to the thresholds due to transient decrease of voltages on the plant VT's.

## H2 - LOGICAL FUNCTIONS ON UNDERVOLTAGE THRESHOLDS (programmable)

3 U< U<<
yyyyyy

Programming of logical functions on undervoltage thresholds; the functions refer only on phase voltages (special functions do not act on the residual voltage thresholds).

The parameter **yyyyyy** can selected between the following:

- NORMAL** standard operation of the undervoltage thresholds; the programmed TRIP output relays on U< and/or U<< trip when at least one of the measured phase voltage is below the threshold values.
- DISABLED** the trip of the output relays related to U< and U<< thresholds is disabled when ALL the measured phase voltages are below the threshold values.
- ENABLED** the trip of the output relays related to U< and U<< thresholds is enabled only when ALL the measured phase voltages are below the threshold values.

**NOTE** - the DISABLE and ENABLE conditions are evaluated independently for each threshold **U<** and **U<<**, therefore depending on the measured voltages could be disabled or enabled the trip related to **U<** threshold and not the trip on **U<<** threshold (e.g. all measured voltages are lower than **U<** value but one of them is not lower than the **U<<** threshold value).

About the time delays related to **U<** and **U<<** threshold please refer to the **NOTE** at point **H1 - TRIP INHIBITION**.

## H3 - LOGICAL FUNCTIONS ON OVERVOLTAGE THRESHOLDS (programmable)

3 U> U>>
yyyyyy

Programming of logical functions on overvoltage thresholds; the functions refer only on phase voltages (special functions do not act on the residual voltage thresholds):

The parameter **yyyyyy** can selected between the following:

- NORMAL** standard operation of the overvoltage thresholds; the programmed output relays on U> and/or U>> trips when at least one of the measured phase voltage is higher than the threshold values.
- DISABLED** the trip related to U> and U>> thresholds is disabled when ALL the measured phase voltages are higher than the threshold values.
- ENABLED** the trip related to U> and U>> thresholds is enabled only when ALL the measured phase voltages are higher than the threshold values.

**NOTE** - the DISABLE and ENABLE conditions are evaluated independently for each threshold U> and U>>, therefore depending on the measured voltages could be disabled or enabled the trip related to U> threshold and not the trip on U>> threshold (e.g. all measured voltages are higher than U> value but one of them is not higher than the U>> threshold value).

About the time delays related to U> and U>> threshold please refer to the **NOTE** at point **H1 - TRIP INHIBITION**.

### 5.10 Parameter values visualization (fig. 3)

#### L1 - L2 - L3 - L4 - L5 - L6 THRESHOLDS STATUS

The actual status of each threshold is displayed; only the thresholds available depending on FUNCTION SELECTION set-up are visualized (ref. paragraph 5.2).

For each threshold are displayed the threshold identification (U<, U> etc.) and the threshold status; the status can show one of the following values:

- ON** active threshold
- OFF** disabled threshold (programmed OFF at ref. E1, par. 5.6)
- OFF\_DIG** threshold programmed active but momentary disabled by a digital input actual status.

Examples:

U<<
ON

U>>
OFF

Uo>
ON

Uo>>
OFF_DIG

#### M1 - M2 OUTPUT RELAY STATUS

The actual status of each output relay is displayed; for each relay the following information is displayed:

- relay identification (R1, R2, R3, R4)
- relay status (ON - activated, OFF - non activated)

Note that ON/OFF do not necessary mean energized or de-energized (see ref. F1).

#### N1 - N2 DIGITAL INPUT STATUS

The actual status of each digital input is displayed.

For each digital input the following information is presented:

- digital input identification (DIG1, DIG2, DIG3)
- digital input status (HI or LO)

## P1 - P2 - P3 - P4 DISPLAY OF MEASUREMENTS

The actual value of the measured voltages is displayed; only the measured voltages (depending on FUNCTION SELECTION - ref. C1, paragraph 5.4) are displayed.

For each voltage the following information is displayed:

- voltage identification (U1, U2, U3, Uo)
- actual value expressed as Un or Uon
- actual primary value expressed as Volts

Examples:

U1= 1.20 24000 V
---------------------

U3= 0.86 8600 V
--------------------

Uo= 0.11 33 V
------------------

## 5.11 Events (fig. 3)

On the display are shown the memorized information related to the last 8 TRIP events.

The 8 events are recorded and identified with a progressive number from 1 to 8; the more recent event shows a lower number.

### Q1 - EVENT NUMBER

E1 cccccccc
----------------

The index E1, E2 ... E8 identifies the memorized event.

The parameter **cccccccc** gives information on the kind of event and it can show one of the following values:

NONE	no event memorized
U<	event on threshold U< trip
U<<	event on threshold U<< trip
U>	event on threshold U> trip
U>>	event on threshold U>> trip
Uo>	event on threshold Uo> trip
Uo>>	event on threshold Uo>> trip
STATUS	information recorded on external command
POWER ON	switch-on of the protection relay (auxiliary power)

For the events NONE and POWER ON no other information is presented: for the other events the following displays give more detailed information on the event.

**Q2 - TRIP THRESHOLD**

E1	U>
x.xx	Un

It shows the threshold related to the TRIP condition of the protection relay and the value of the threshold (in relative terms). The information is not shown on STATUS or POWER ON events.

**Q3 - ACTIVATED OUTPUT RELAYS**

E1 RELAY
nnnnnnnn

It shows the list of the output relays activated by the threshold trip.

Examples:

E1 RELAY
1, 3, 4

E3 RELAY
1, 4

When no output relays have been activated (no relays programmed to TRIP on the threshold) the following message will be displayed:

E1 RELAY
NONE

**Q4 - TOTAL TIME DELAY TO TRIP**

E1 T-Tot
www.ww s

It is shown the total delay to the TRIP of the output relays from the under or overvoltage detection; when additional delays are activated, the change of the status of the digital input that controls the additional delay during the delay itself could bring to a total time different from the sum of the programmed delays. If the total time is greater than 999 seconds the display of tenths is omitted.

When the event is memorized on external command (STATUS), the message N/A (Not Applicable) is shown instead of the number of seconds.

E1 T-Tot
N/A

**Q5 - DIGITAL CHANNELS RELATED TO MEMORIZED EVENT**

E1 DIG
1, 3, 4

The list of the digital inputs related to the memorized event is displayed (STATUS function command or additional time TA enabled - rif. E4 par. 5.6).

If no digital inputs were activated, the message **NONE** is displayed.

**Q6 - ACTIVE SPECIAL FUNCTIONS**

E1 F.SPE
1,3

The list of the active special functions at the memorized event is displayed using the following values:

- 1 Trip inhibition when all voltages are lower 0.2 Un (see H1 - par. 5.9)
- 2 Logical function on undervoltage thresholds (see H2 - par. 5.9)
- 3 Logical function on overvoltage thresholds (see H3 - par. 5.9)

If no functions are activated the message **NONE** is displayed.

**Q7 - Q8 - Q9 - Q10 - MEMORIZED MEASURED VOLTAGES ON EVENT**

E1 U1	E1 U2	E1 U3	E1 Uo
y.yy Un	y.yy Un	y.yy Un	y.yy Un

The values of the measured voltages at the event are displayed; the values are expressed as Un and Uon terms.

There are presented only the voltages measured coherently with the selection on FUNCTION SELECTION set-up (ref. C1 – paragraph 5.4).

**Q11 - Q12 - Q13 - DIGITAL INPUTS STATUS ON EVENT**

E1	E1	E1
DIG1 vv	DIG2 vv	DIG3 vv

The status of the digital inputs at the event are displayed.

The parameter **vv** can assume the value HI or LO.

**Q14 - Q15 - DATE AND TIME OF THE EVENT**

E1 Date	E1 Time
dd/mm/yy	hh:mm:ss

The date and time of the event are showed

**5.12 Trip counters (fig.3)**

In this section are displayed the total and partial counters of the output relay activation (on TRIP conditions) for each thresholds and the numbers of programming sessions with the date and time of the last confirmed programming session.

The total counters, the number of confirmed programming sessions and the date and time of the last confirmed programming session are not modifiable or resettable; the information related to the last programming session are used to control unauthorized access.

The partial counter can be modified following the standard set-up procedure for parameters as described at paragraph 4.2; the partial counters are immediately modified in the memory (the recorded values are immediately resetted without the need of the programming confirmation).

### R1 ÷ R12 - TRIP COUNTERS

U>	
P	cccc

U>	
T	cccc

Display of the partial (P) and total (T) counters of the TRIP condition related to each threshold.

When the value exceed 9999 the counter starts again from 0000.

The counters are identified by the threshold name (U<, U<<, Uo>, etc.); they are presented only the counters related to the active thresholds coherently with the selection on FUNCTION SELECTION set-up (ref. C1 - paragraph 5.4).

The partial counters are modifiable in the range from 0000 to 9999 following the standard set-up procedure (paragraph 4.2).

### R13 ÷ R15 TOTAL PROGRAMMING SESSIONS AND DATE/TIME OF THE LAST PROGRAMMING SESSION

TOT PRG
eeee

DATE PRG
dd/mm/yy

TIME PRG
hh:mm:ss

Display of the number of confirmed programming sessions (from the factory set-up) and the date and time of the last confirmed programming session.

## 6 INSTALLATION

### 6.1 Supplied kit

**RK VERSION - 19" rack installation** (the proper rack is supplied by SEB)

- protection relay module UAR4N with rear socket
- transparent front panel for rack installation
- blister with items 1-2-3-4-5

**CS VERSION - flush mounting installation**

- protection relay module UAR4N with rear socket
- transparent front panel for rack flush mounting installation
- n° 2 brackets for flush mounting
- blister with items 1-2-3-4-5
- blister with item 6

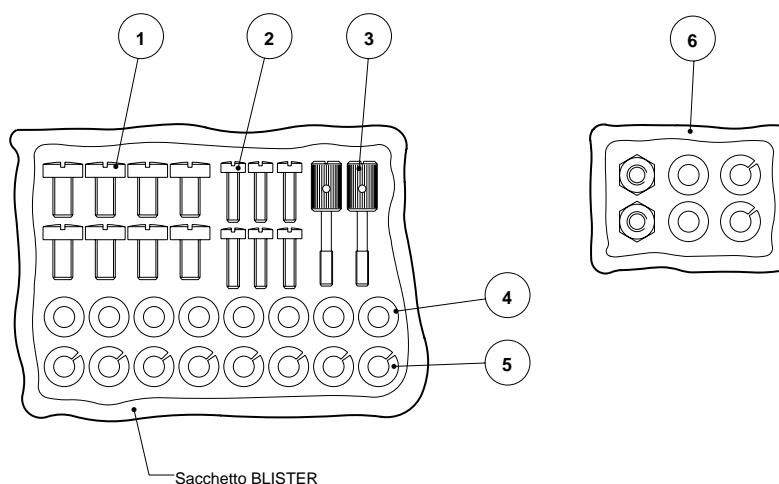

- 1) n° 8 screws to fix wire terminals of current circuits (NOT USED)
- 2) n° 4 screws to fix the relay rear socket on the 19" rack (or on the two brackets for flush mounting) and n° 2 screws to fix (optionally) the protection relay on the front of the 19" rack
- 3) n° 2 knobs to fix the transparent front panel
- 4) n° 8 washers to be used to fix wire current terminals (NOT USED)
- 5) n° 8 growers to be used to fix wire current terminals (NOT USED)
- 6) small items to fix brackets on the cabinet (only CS version)

The knobs to fix the transparent front panel must be screwed through the front panel itself; the operation will create a screw thread in the plastic material to prevent knob missing.

**NOTE** The items related to current inputs are the standard supplied items with all SIGMA N protection relays but for the UAR4N model they are not used.

## 6.2 Cabling

### Voltage circuits

It is suggested to terminate the voltage wirings using plug terminals.

Minimum suggested wire cross section: 1,5 mm<sup>2</sup>

With reference to the insertion diagram in the next page, the voltages measured by the protection relay have the following matching:

U1	terminals 1 – 3	voltages with Un programmed from 110 to 380 V
	terminals 2 - 3	voltages with Un programmed from 0 to 100 V
U2	terminals 6 – 8	voltages with Un programmed from 110 to 380 V
	terminals 7 - 8	voltages with Un programmed from 0 to 100 V
U3	terminals 11 – 13	voltages with Un programmed from 110 to 380 V
	terminals 12 - 13	voltages with Un programmed from 0 to 100 V
Uo	terminals 16 – 18	voltages with Uon programmed from 110 to 380 V
	terminals 17 - 18	voltages with Uon programmed from 0 to 100 V

For 2-phase functions only the voltages U1 and U2 are measured; for the functions as residual voltage (59N or 59 Vo) or stator earth fault 95% (64S) only the voltage Uo is measured.

The input terminals related to Uo have to be connected to a VT sensible to residual voltages (e.g. star-open delta VT module).

### Other circuits( output relays etc.)

It is suggested to terminate the wiring using plug terminals.

Minimum suggested wire cross section: 1,5 mm<sup>2</sup>



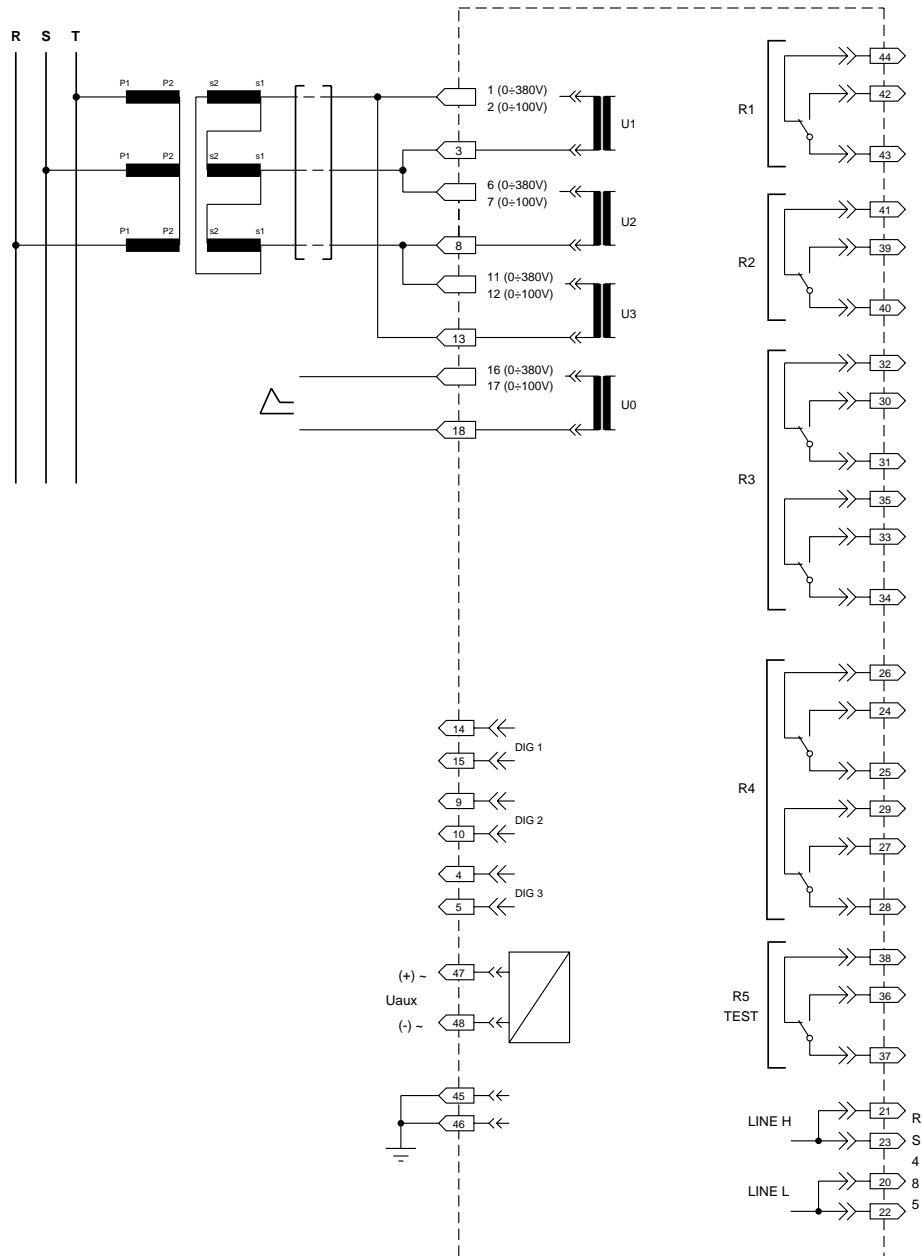

**STAR - DELTA Insertion**

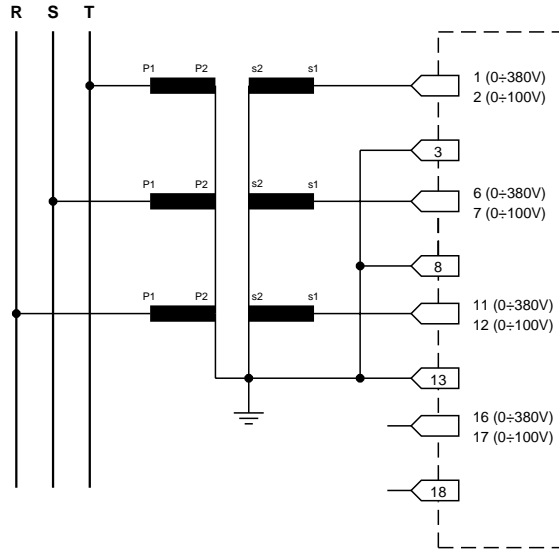

**STAR - STAR Insertion**

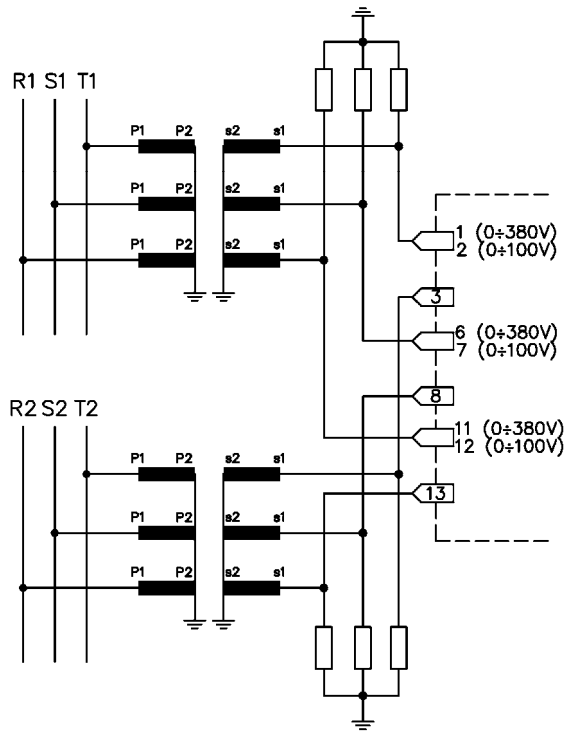

**VOLTAGE BALANCE (ANSI 60) Insertion**

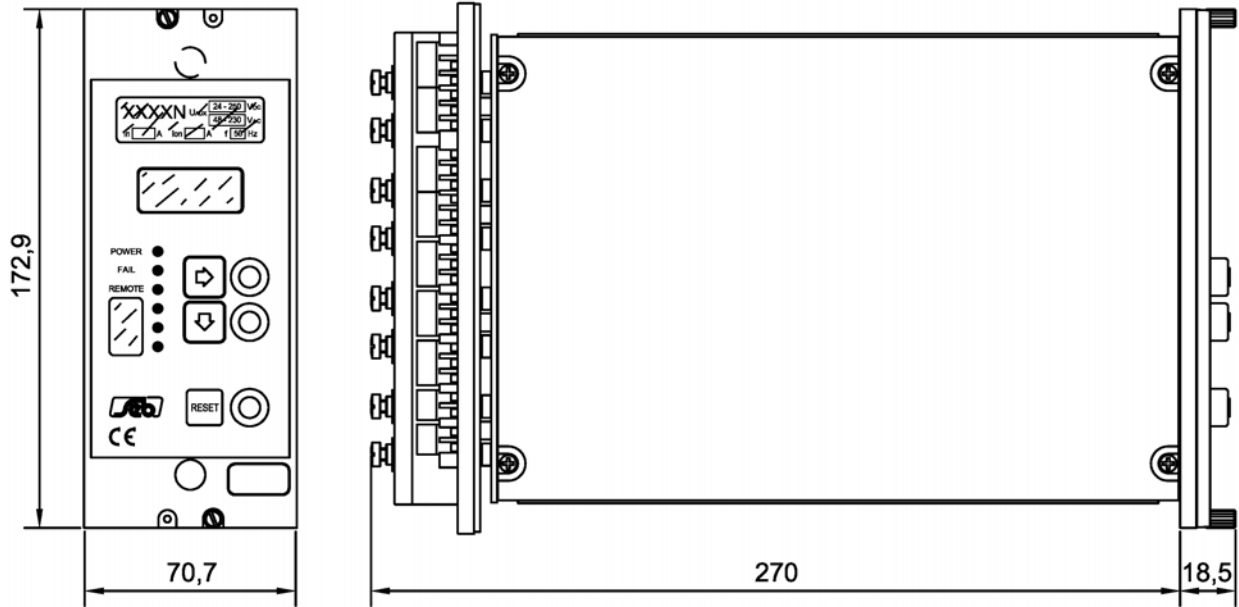

Dimensioni meccaniche  
Case outlines

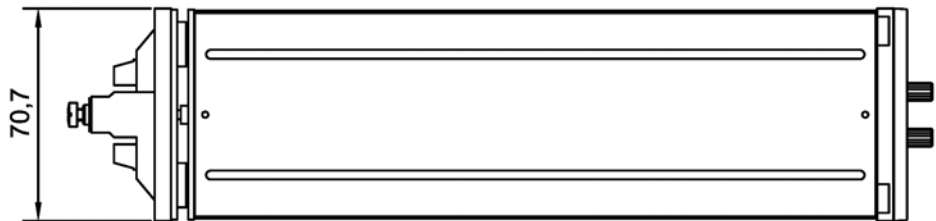

Dima montaggio da incasso  
Flush mounting panel cut - out

Montaggio incassato / Flush mounting  
Dimensioni pannello frontale trasparente :  
Transparent front panel sizes :  
208 x 89,5 mm.

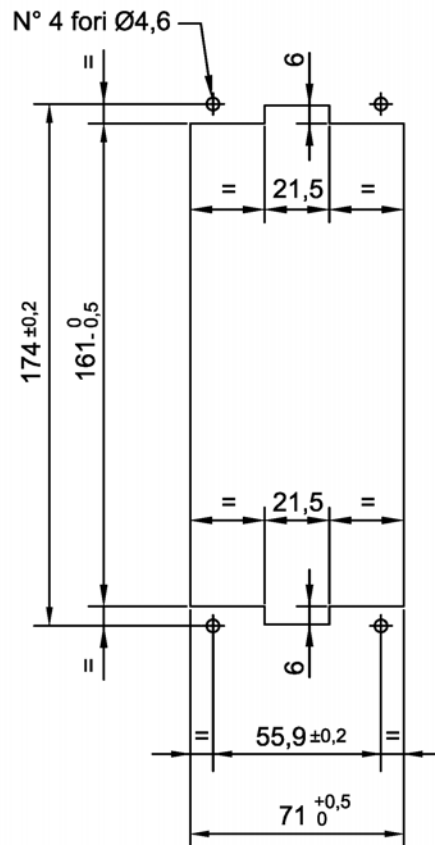

### 6.3 Relays R3 and R4 - Signalling / Command set-up

The protection relay is supplied with R3 and R4 relays configured as **SIGNALLING RELAYS**, with 2 change-over output contacts with breaking capability equals to 0.2 A at 110 Vdc, L/R = 40 ms, 100000 operations.

Each R3 and R4 relay can be configured as **COMMAND RELAY** with 1 change-over output contact with breaking capability equals to 0.5 A at 110 Vdc, L/R = 40 ms, 100000 operations.

The new configuration is obtained with the following cabling:



### 6.4 RS485 serial communication port

The digital protection relay UAR4N presents an insulated serial interface RS485 half-duplex that allow the multi-drop connection up to 31 protection units.

When the STANDARD Seb communication protocol is selected, the transmission speed is automatically selected between 300 to 9600 bauds and the protocol is ASCII-HEX; the documentation related to the protocol is freely available on request.

When the MODBUS communication protocol is selected, the transmission speed can be programmed between 300 to 9600 bauds (ref. B3, par. 5.3).

It is suggested to use a shielded twisted pair AWG22; terminal 19 (not connected internally) can be used for shields connections.

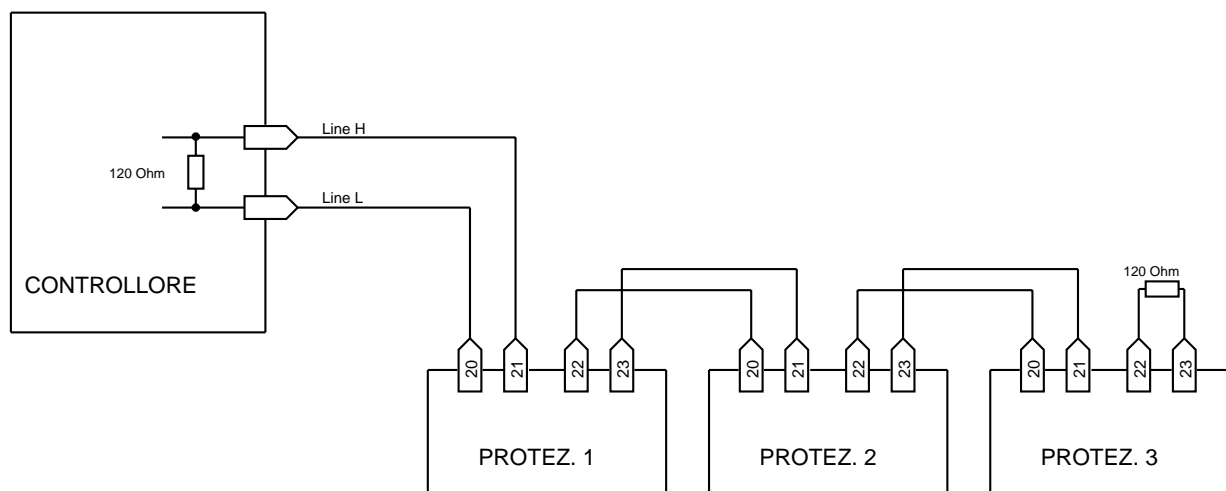

It is suggested to terminate the serial line with a resistance 120 Ω, 1/4 W.

# 7 TIME DEPENDENT CURVES

Curva - Curve A

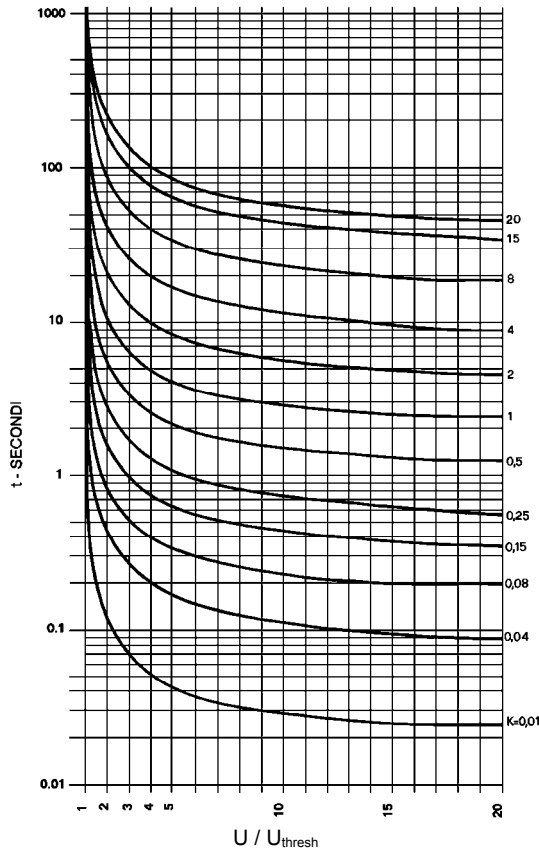

Curva - Curve B

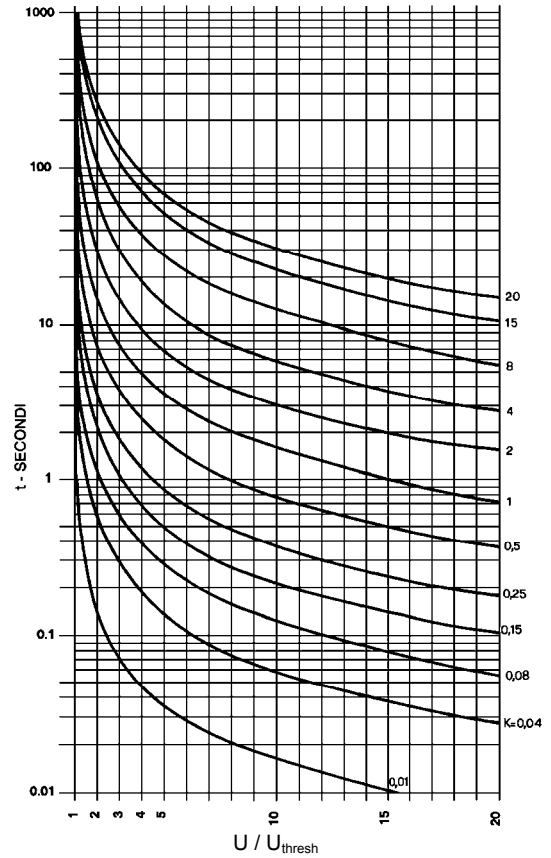

Curva - Curve C

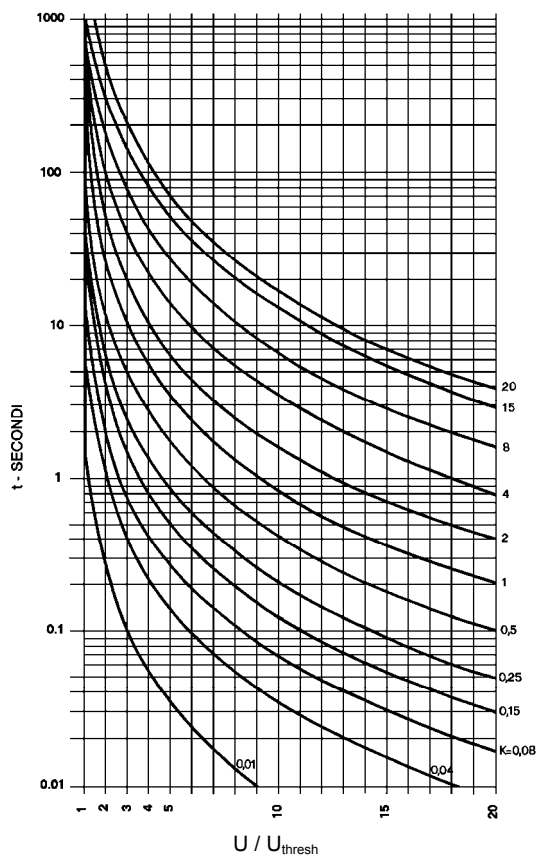

Time dependent characteristic

$$t = \frac{K_i * K}{\left(\frac{U}{U_{thresh}}\right)^\alpha - 1} + 0.02s$$

Curve IEC 255-4	A	B	C
K <sub>i</sub>	0.14	13.5	80
α	0.02	1	2
K	Parameter 0.01 ÷ 20.00 s		
U/U> U <sub>o</sub> /U <sub>o</sub> >	Ratio between the greatest measured voltage and the threshold U> or U <sub>o</sub> >		
U</U	Ratio between the threshold U< and the lowest measured voltage		

## 8 TECHNICAL CHARACTERISTICS

### Measuring inputs

Rated line voltage (Un) and residual voltage (Uon)	programmable 57.73 – 63.50 – 72.16 - 100 - 110 V 125 - 190 – 220 - 230 - 380 - 400 V
Thermal withstand continuously	2 Un – Uon
Thermal withstand for 1 s	2 Un – Uon
Rated frequency	50 / 60 Hz
Primary VT's voltage	1 - 999999 V

### Output contacts ratings

Number of relays (note 1)	4 + 1
Rated current	5 A
Rated voltage	250 V
Contact configuration	change over
Breaking capability (note 2)	
- tripping relays (R1, R2)	0.5 A
- signalling relays (R3, R4, R5) (note 3)	0.2 A
Mechanical life	> 10 <sup>6</sup>

### Digital inputs

Number of inputs	3
External control voltage	as Uaux
Typical current (sink)	2 mA

### Data transmission

Standard	RS485 half duplex
Communication protocol	MOD-BUS ASCII
Transmission speed	300 - 9600 baud selectable
Optional	fibre optic module

### Auxiliary supply

Range	24 ÷ 320 Vdc ± 20% 48 ÷ 230 Vac ± 20%
Frequency (Vac)	47 ÷ 63 Hz
Burdens (min/max)	5 / 10 W

### Environmental conditions

Operation	- 10 / +60 °C
Transport and storage	- 25 / +80 °C
Relative humidity (without condensation)	< 95%
Protection degree for flush mounting (optional)	IP 52 (IP 54)
Weight	2.5 kg

- Note 1) The additional relay R5 is controlled by self-test program  
 Note 2) Breaking capability at 110 Vdc, L/R 40 ms, 100.000 operations  
 Note 3) The output contacts of R3 and R4 relays can be configured as signalling or tripping relays

## 9 TABLES

**Table A Rated values and settings**

<b>THRESHOLDS</b>	<b>U&lt;, U&lt;&lt;</b>	<b>U&gt;, U&gt;&gt;</b>	<b>Uo&gt;, Uo&gt;&gt;</b>
Setting	0.30 ÷ 1.60 Un / OFF	0.30 ÷ 2.00 Un / OFF	0.01 ÷ 1.60 Uon / OFF
Resolution	0.01 Un	0.01 Un	0.01 Uon
<b>TRIP DELAYS</b>			
Definite time Setting	0.02 ÷ 99.99 s	0.02 ÷ 99.99 s	0.02 ÷ 99.99 s
Resolution	0.01 s	0.01 s	0.01 s
<b>Dependent time U&lt;, U&gt;, Uo&gt;</b>			
Characteristic curves (IEC-255)	A, B, C	A, B, C	A, B, C
Characteristic constant	0.01 ÷ 20.00 s	0.01 ÷ 20.00 s	0.01 ÷ 20.00 s
Resolution	0.01 s	0.01 s	0.01 s
<b>Additional delay</b>	0.00 ÷ 99.99 s	0.00 ÷ 99.99 s	0.00 ÷ 99.99 s
<b>OTHER VALUES</b>			
Burden referred to the rated value	0.3 VA / phase		0.3 VA / phase
Drop-off ratio	≤ 1.05	≥ 0.95	
Overshoot time	≤ 30 ms		
Output relays R1, R2, R3, R4	Configurable for each thresholds STRAT / TRIP - normally ON / OFF		

**SEB DIVISIONE ELETTRONICA E SISTEMI - UFFICIO COMMERCIALE**  
Via Segantini, 5 - 20825 BARLASSINA (MB) - **tel.** +39 0362 5669.1 - **fax** +39 0362 556622  
web: [www.seb-barlassina.it](http://www.seb-barlassina.it)  
mail to: [servizio-clienti@seb-barlassina.it](mailto:servizio-clienti@seb-barlassina.it)