

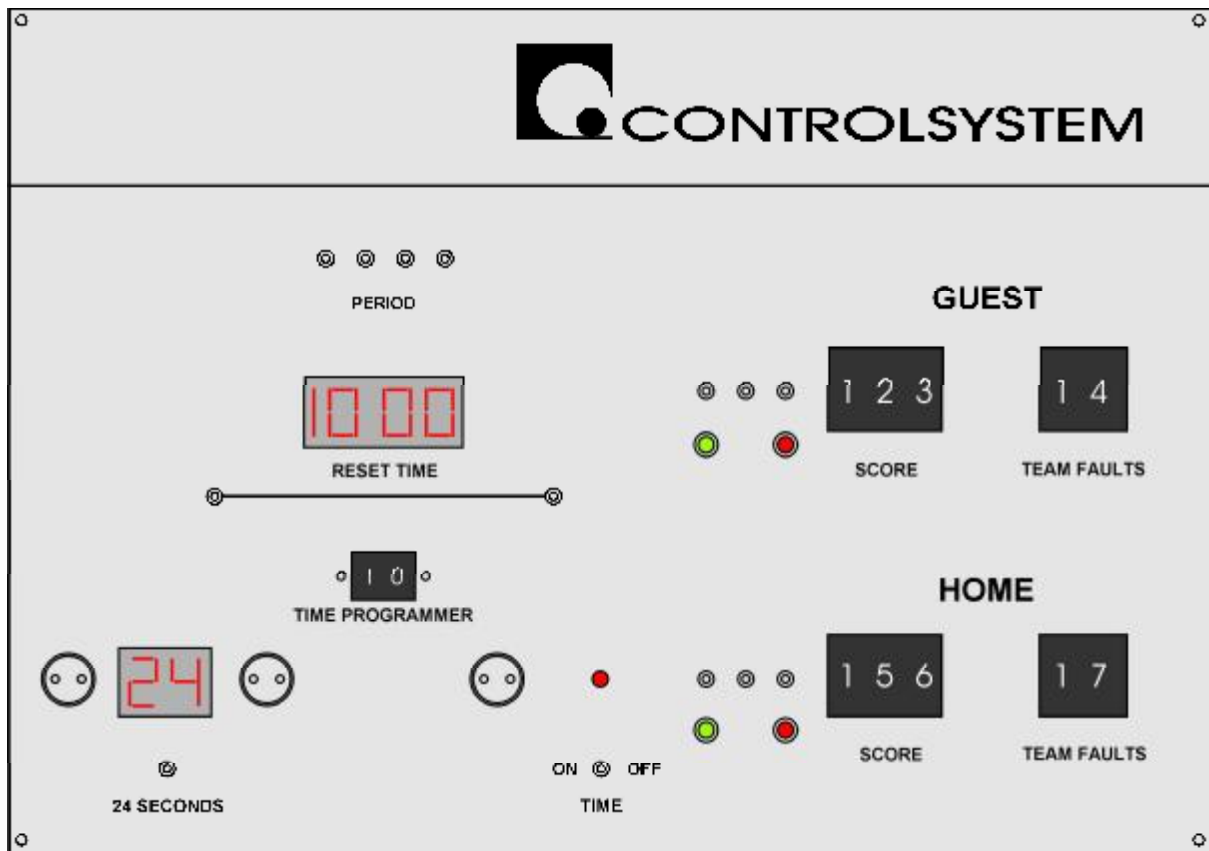

ALL - PURPOSE

ELECTRONIC SCOREBOARD

OPERATING INSTRUCTIONS



Here above, you can find the graphic representation of the remote console.
 All data shown on the central part of the scoreboard are present on the console.
 It is possible to split console in three different parts :

- Timing
- 24 seconds (optional)
- Scoring and team fouls

CONSOLLE

- **Timing**

Located on the left side of the console

Periods

Four switches, one per

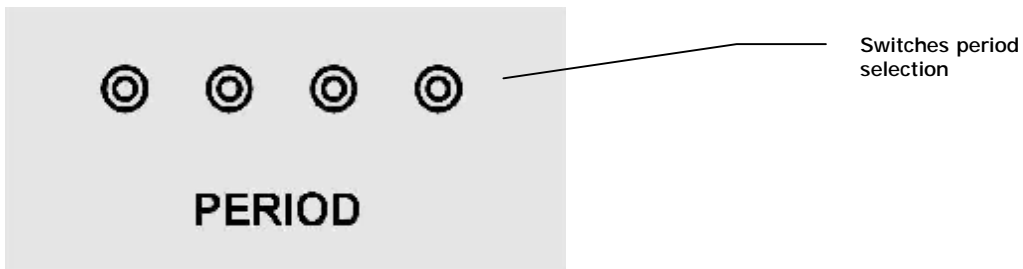

Timing

The display shows the game timing (increasing).

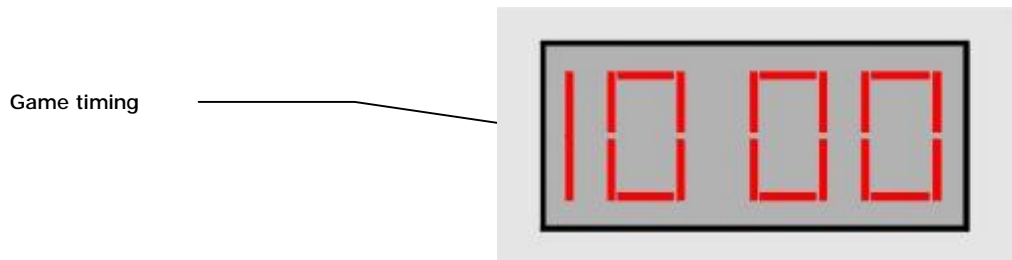

Timing selector

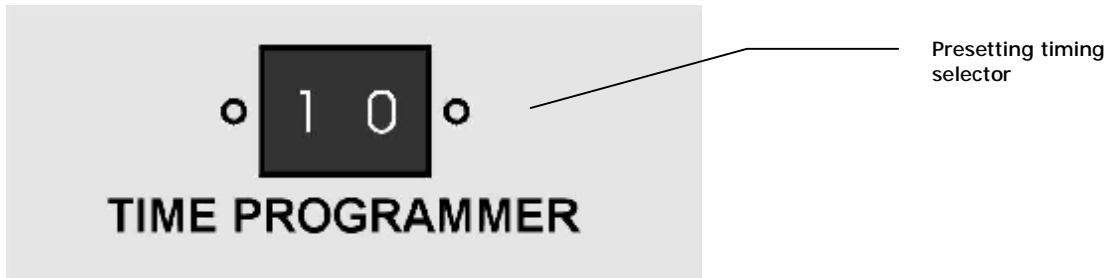

It allows to select the game timing from 0 to 99 minutes.

Zero setting buttons

Both buttons must be pushed in the same time

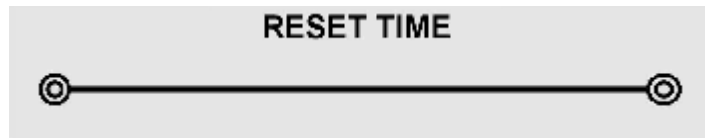

Timing control

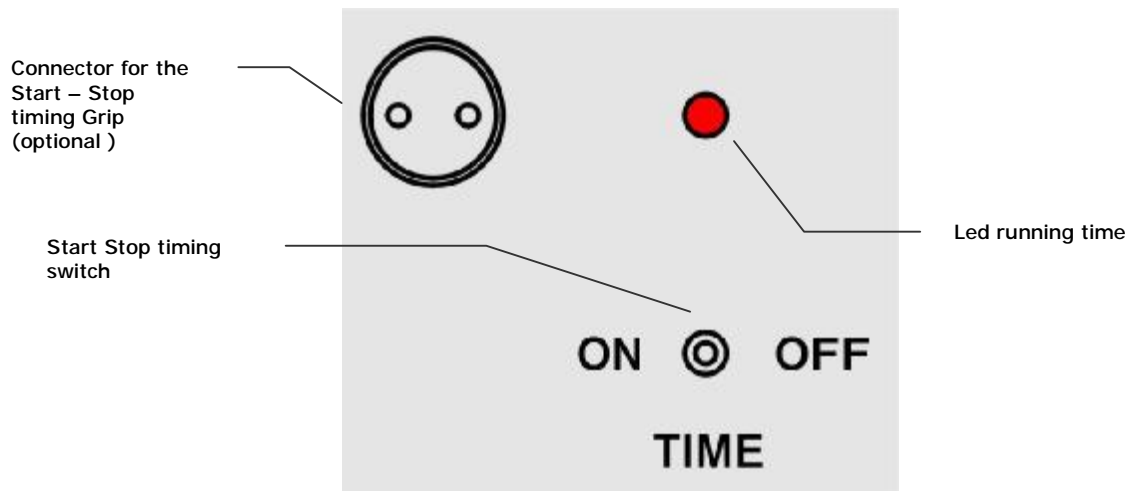

- Scoring and team fouls

GUESTS

From 0 to 199.

Scoring selector

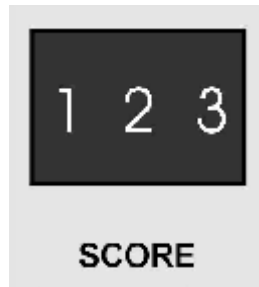

From 0 to 19

Team fouls selector

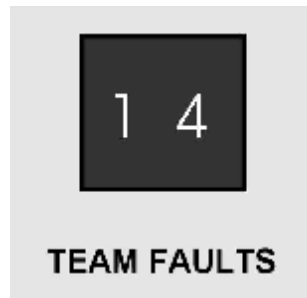

Time Out indicators switches

Pushing the switches, three lights for each team will be turned on.



HOME

Same as per GUEST section

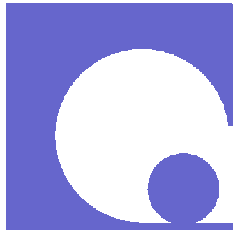

CONTROLSYSTEM

Consolle wiring

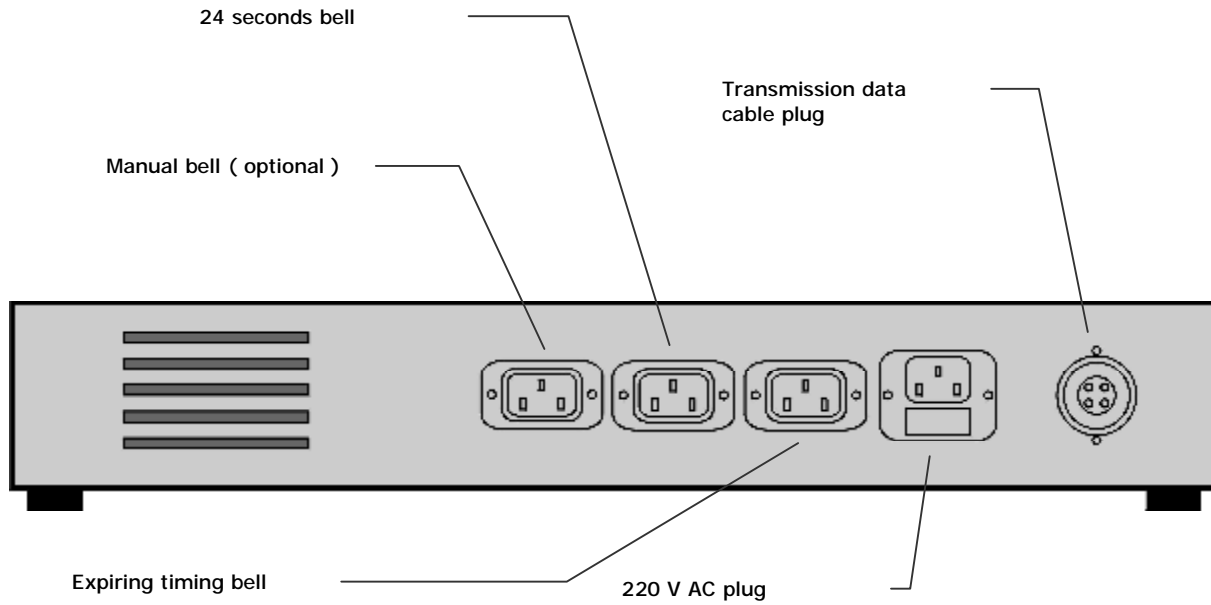

Transmission data cable

- Pin 1 – RED wire
- Pin 2 – WHITE wire
- Pin 3 – YELLOW wire
- Pin 4 (identified with this symbol \equiv) – GREEN wire

Connection layout

