

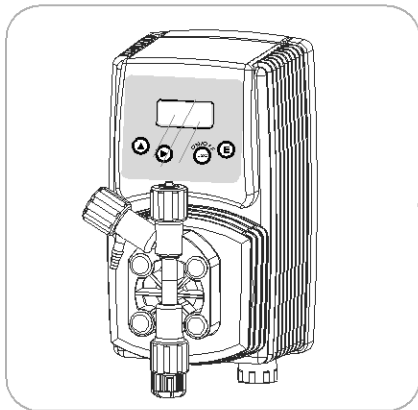

This operating instructions contains safety information that if ignored can endanger life or result in serious injury. They are indicated by this icon.



Use of this pump with radioactive chemicals is forbidden!



OPERATING INSTRUCTIONS MANUAL FOR "VMS" PUMPS



Keep the pump protected from sun and water. Avoid water splashes.

Please read it carefully!



English language

R1-05-06



“VMS” series solenoid dosing pumps comply with the following European regulations:

EN60335-1 : 1995, EN55014, EN50081-1/2, EN50082-1/2, EN6055-2, EN60555,3

Based on directive CEE 73/23 c 93/68 (DBT Low voltage directive) and directive 89/336/CEE (EMC Electromagnetic Compatibility)



GENERAL SAFETY GUIDELINES

Danger!

In emergencies the pump should be switched off immediately! Disconnect the power cable from the power supply!

When using pumps with aggressive chemicals observe the regulations concerning the transport and storage of aggressive fluids!

When installing outside European Community, always observe national regulations!

Manufacturer is not liable for any unauthorized use or misuse of this product that can cause injury or damage to persons or materials!

Caution!

Pumps must be accessible at all times for both operating and servicing. Access must not be obstructed in any way!

Feeder should be interlocked with a no-flow protection device to automatically shut-off the pump when there is no flow!

Pumps and accessories must be serviced and repaired by qualified and authorized personnel only!

Always discharge the liquid end before servicing the pump!

Empty and rinse the liquid end before work on a pump which has been used with hazardous or unknown chemicals!

Always read chemical safety datasheet!

Always wear protective clothing when handling hazardous or unknown chemicals!

Introduction:

Metering Pumps "VMS" Series are the ideal solution for low / middle dosing of chemicals. All control and setup parameters are available through a digital keyboard and they are displayed on a LCD backlit display. Pump has "Level" input.

Pump's capacity

Flow rate is determined by the stroke length and by the stroke speed. The stroke length is adjustable from 0 to 100% using the stroke length adjustment knob. However dosing accuracy is guarantee within an adjustment range from 30% to 100%.

Modes:

VMS PH

Proportional pump driven by internal built-in pH meter (0 ÷ 14 pH) and level control. pH electrode input (electrode not included).

VMS RH

Proportional pump driven by internal built-in Redox (ORP) meter (0 ÷ 1000mV) and level control. Redox electrode input (electrode not included).

Capacity:

Pressure <i>bar</i>	Capacity <i>l/h</i>
20	1
18	2
18	4
15	2
15	4
15	5
10	4
10	5
10	10
7	6
5	10
5	12
4	8
3	10
2	14
1	16

2. Unpacking

Included into package:

- n.4 Dibbles $\varnothing 6$
- n.4 Self tapping screws 4,5 x 40
- n.1 Delayed fuse 5 X 20
- n.1 Foot filter with valve
- n.1 Injection valve
- n.1 Level probe
- m 2 Delivery pipe* (opaque PE)
- m 2 Suction pipe * (transparent PVC)
- m 2 Discharge pipe (transparent PVC)
- n.1 This installation manual

* If hose is 6x8 there is only a 4meters long hose.
Cut to obtain suction and delivery hoses.

Remove the contents from the box.

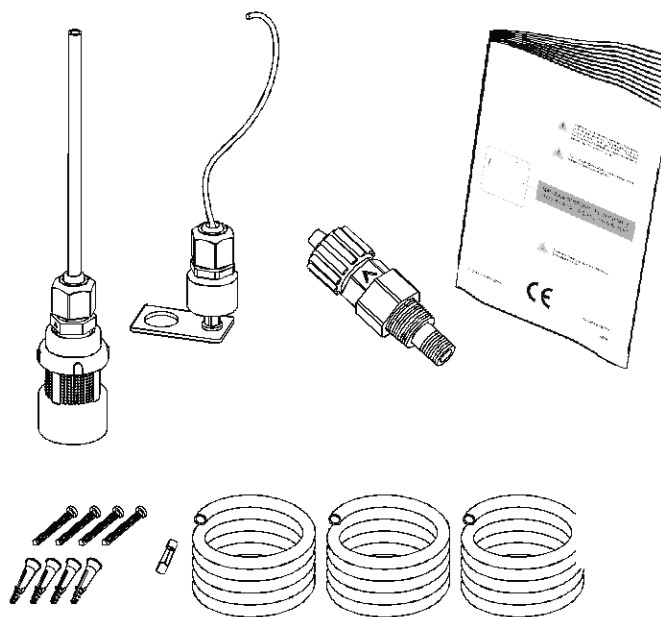

**PLEASE DO NOT TRASH PACKAGING.
IT CAN BE USED TO RETURN THE PUMP.**

3. Pump's description

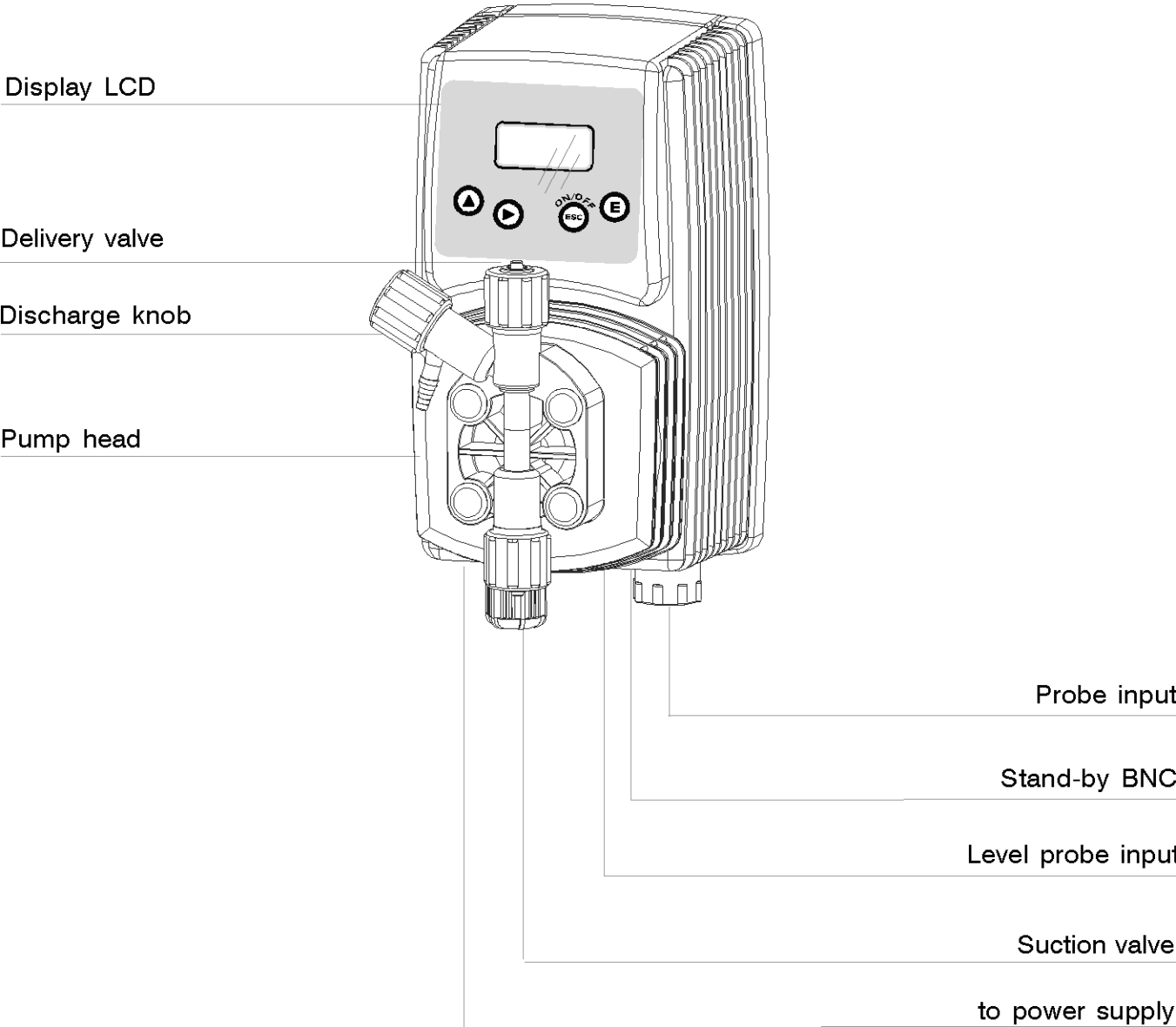

4. Before to Install warnings

Pump's installation and operativity is made in 4 main steps:

Pump's installation
Hydraulic Installation (hoses, level probe, injection valve)
Electrical Installation (main power connection, priming)
Programming the pump.

Before to start, please read carefully the following safety information.

Protective clothes



Wear always protective clothes as masks, gloves, safety glasses and further security devices during ALL installation procedure and while handling chemicals.

Installation location



Pump must be installed in a safety place and fixed to the table / wall to avoid vibration problems!

Pump must be installed in a easy accessible place!

Pump must be installed in horizontal position!

Avoid water splashes and direct sun!

Hoses and Valves



*Suction and delivery hoses must be installed in horizontal position!
All hoses connections must be performed using only hands' force!
No tongs required!*

Delivery hose must be firmly fixed to avoid suddenly movements that could damage near objects!

Suction hose must be shorter as possible and installed in vertical position to avoid air bubbles suction!

Use only hoses compatibles with product to dose! See chemical compatibility table at page 30. If dosing product is not listed please consult full compatibility table or contact chemical's manufacturer!

5. Installation Draw

Pump must be installed in a wall support at a maximum height (from tank's bottom) of 1,5 meters.

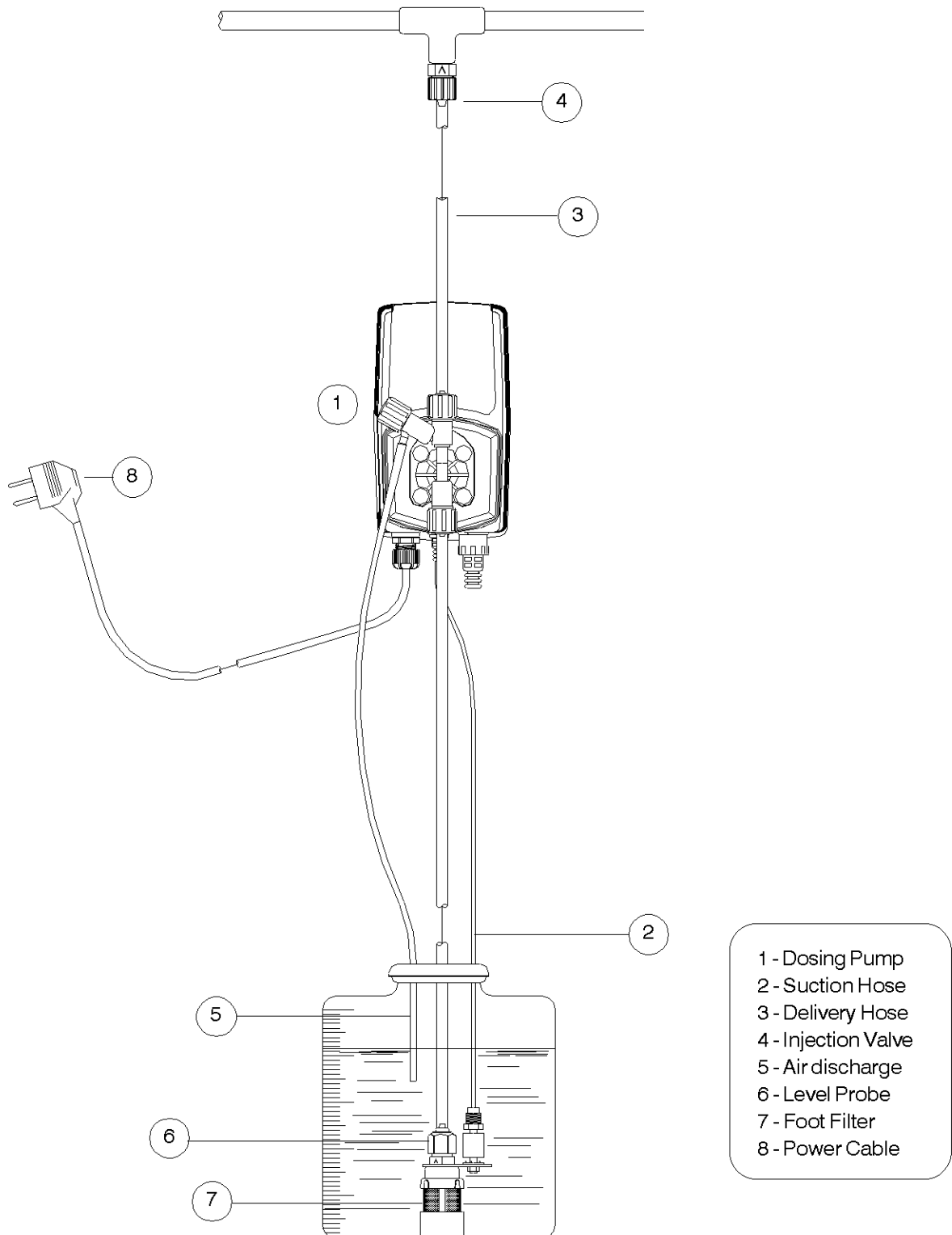

6. Hydraulic Installation

Hydraulic connections are:

Suction Hose with level probe and foot filter
Delivery Hose with injection valve
Discharge Hose

Suction Hose.

Completely unscrew tightening nut from pump's head and remove assembling components: *tightening nut, holding ring and pipe holder.*

Assembly as shown in fig. (A). Insert hose into pipe holder until it reaches the bottom.

Lock hose on pump's head by screwing down the tightening nut.
Use only hands to do it!

Connect other side of the hose to the foot filter using the same procedure.



fig. (A)

Assembling foot filter with level probe.

Level probe must be assembled with foot filter using the provided kit. Foot valve is made to be installed into tank's bottom without sediments priming problem.

Completely unscrew level probe's nut and assembly as described in fig. (B) **paying attention to the black ring: it must be inserted from floater side.** Lock nut on the opposite side of the floater using hands only.

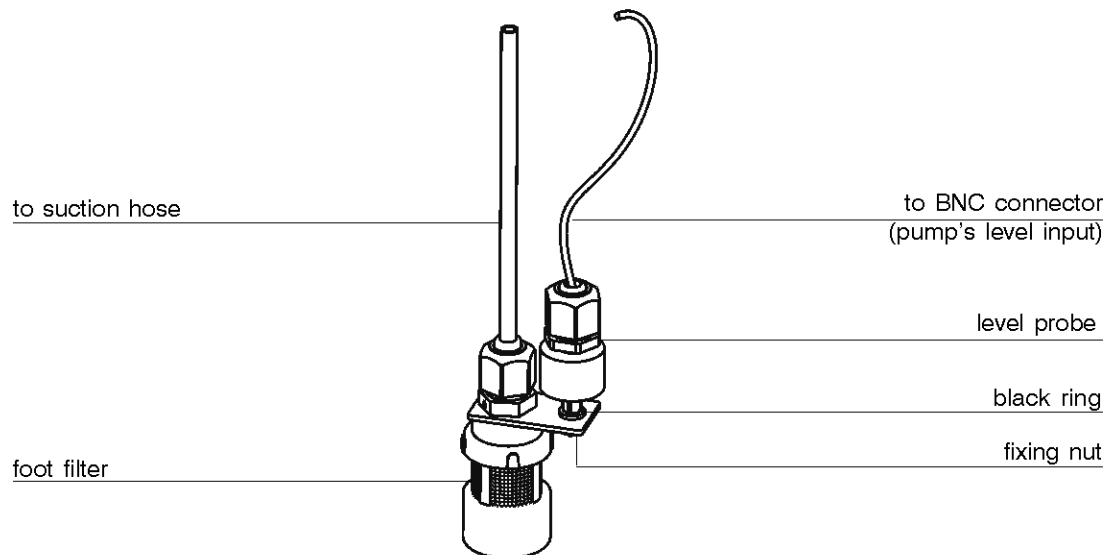

fig. (B)

Connect BNC from level probe into pump's level input (front side of the pump). Put level probe assembled with foot filter into tank's bottom.

Warning: If there is a mixer installed into tank, install a suction lance instead of level probe / foot filter.

Delivery Hose.

Completely unscrew tightening nut from pump's head and remove assembling components: *tightening nut, holding ring and pipe holder.*

Assembly as shown in fig. (A). Insert hose into pipe holder until it reaches the bottom.

Lock hose on pump's head by screwing down the tightening nut. Use only hands to do it!

Connect other side of the hose to the injection valve using the same procedure.

6. Hydraulic Installation

Injection Valve.

Injection valve must be installed on plant from water's input.
Injection valve will open at pressure greater than 0,3bar.

Discharge hose.

Insert one side of discharge hose into discharge connector as shown in fig (C).

Insert other side of discharge hose into product's tank.
During priming procedure product exceeding will flow into tank.

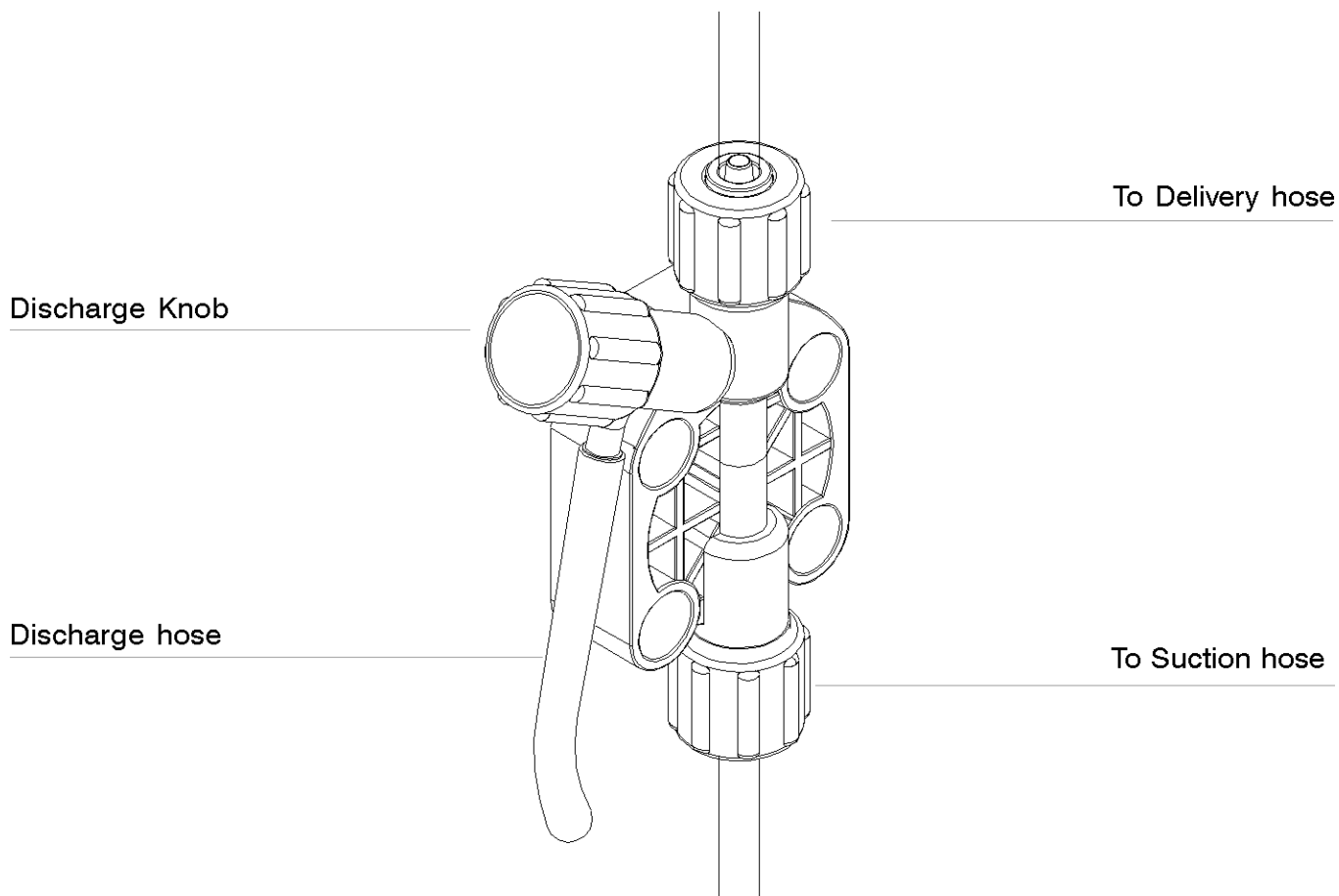
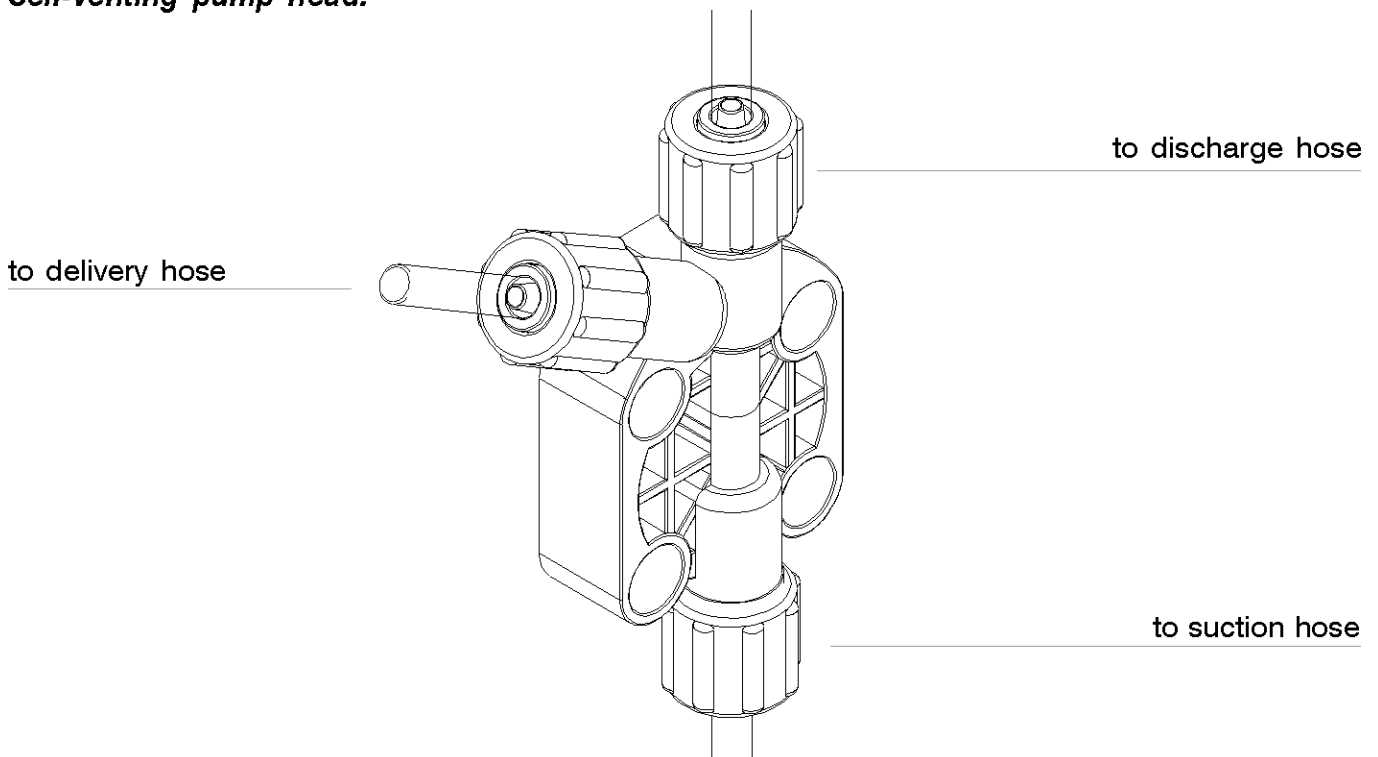

fig (C)

For priming procedure see page 14.

Self-venting pump head.



Self-venting pump head must be used when using chemicals that produce gas (i.e. hydrogen peroxide, ammonium, sodium hypochlorite at particular conditions).

Hoses assembling procedure (*including purge hose*) is described in fig. (A).

Notes:

- suction, delivery and purge valves are DIFFERENT! Do not exchange them!
- delivery and purge hoses are made of same material!
- it's allowed to lightly bend discharge hose!
- during calibration procedure ("TEST") insert discharge hose into BECKER test-tube!

7. Electrical Installation

All electrical connections must be performed by **AUTHORIZED AND QUALIFIED** personnel only. Before to proceed, please, verify the following steps:

- verify that pump's label values are compatible with main power supply.
- pump must be connected to a plant with a differential switch (0,03A sensitivity) if there isn't a good ground.
- to avoid damages to the pump do not install it in parallel with heavy inductance load (for example: engines). A relay switch must be used. See below picture.

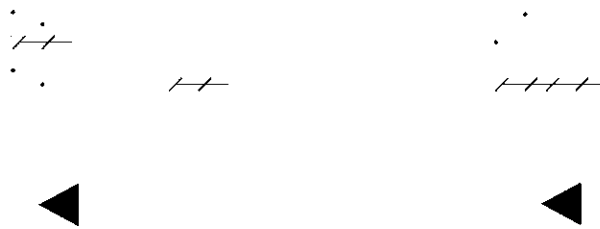

P - Dosing Pump
R - Relay
I - Switch or safety device
E - Electrovalve or inductance load
A - Main Power

- On pump's mother board there is a further protection against over voltages (275V - 150V) and distribution line noises (4KV for max 50 μ sec) as shown:

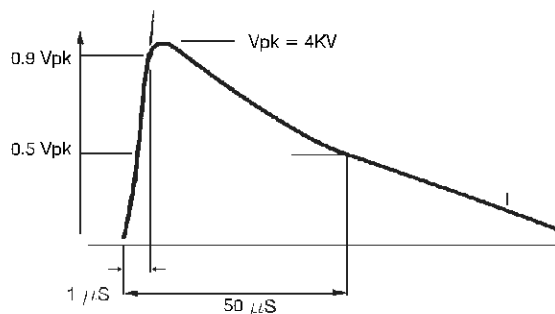

7. Electrical Installation

Once verified previous steps proceed as follows:

- check that “BNC” of level probe has been connected as described in “Hydraulic Installation” chapter.
- connect “BNC” and external signal to pump’s “INPUT” connectors.

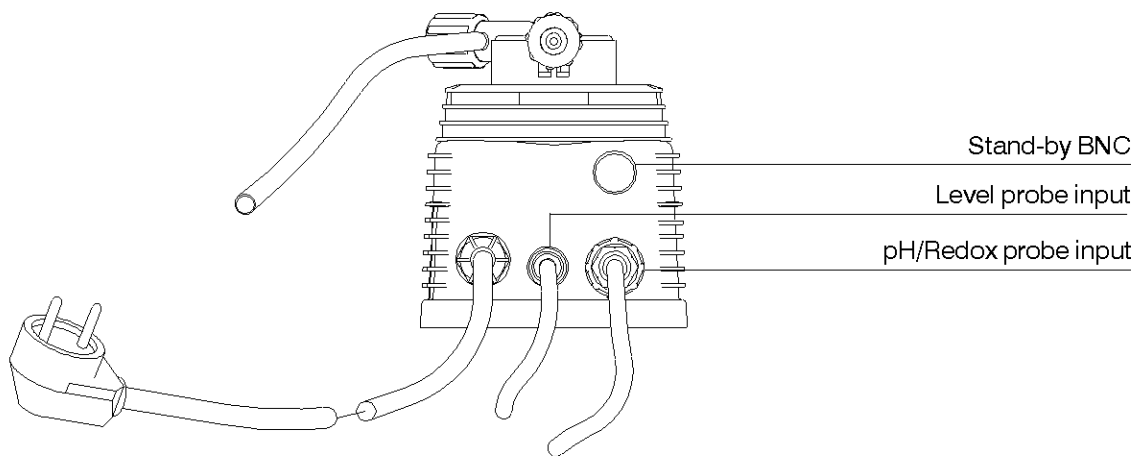

8. Basic Settings

All dosing pumps are equipped with a keyboard that basically works in the same way for any pump's model. To avoid any misunderstanding during this chapter all keys will be described as shown on this legend:



is the "UP", "ON/OFF" key



is the "DOWN", "SCROLL" key



is the "RIGHT", "ESC" key



is the "E" key

PRIMING

To prime the pump without touching chemicals please performs these operations:

- connect all hoses into proper places (delivery hose, suction hose and outgassing hose).
- open outgassing valve and turn on the pump.
- set pump's single injection at 100% and pulses at 50%.

All air inside the pump head will exit through the outgassing outlet. When product will leak from it, close immediately the outgassing valve. If dosing product is particularly dense, to facilitate the priming, insert on vent pipe a syringe of 20 cc and suck inside.

PROGRAMMING “VMS PH” PUMP

Entering in program mode

Turn on the pump. Keep pressed “E” key for at least 4 seconds to enter in program mode. Pump’s display shows:

PASSWORD:

→ 0000 fig.1

Use “UP” and “DOWN” keys to edit the password, press “RIGHT” to move on next digit.

“SETUP” program

Once entered the password, pump’s display shows:

→ SETUP
PARAM fig.2

Move arrow on SETUP then press “E” key:

“SET POINT” program

Setup
1) Point fig.3

Press “E” key:

a) → 00%
7.30pH fig.4

The display shows that pump does not work at 00% if pH is 7.30. Make sure that arrow is on “7.30 pH” to change this value, then use “UP” and “DOWN” keys to enter a new value. Use “RIGHT” key to move on next value. Once on “00%”, change it with “UP” and “DOWN” keys. It’s possible to choose “OFF” instead of a number for “On/Off” working mode.

b) → 100%
7.80pH fig.5

The display shows that pump works when pH is 7.80. Make sure that arrow is on “7.80pH” to change this value, then use “UP” and “DOWN” keys to enter a new value. Use “RIGHT” to move on next value. Once on “100%”, change it with “UP” and “DOWN” keys. Press “E” key to confirm values and quit from programming mode. Display shows for a few seconds: DATA SAVED. To exit from program mode press “RIGHT” key twice. Now the pump will modify proportionally its own dosing capacity in the range between 7.30pH and 7.80pH. On previous example, dosing mode is for “acid”. It’s possible to choose “ON” for “On/Off” working mode.

9. Programming the pump

Probe calibration

To obtain a reliable measurement it is necessary (during installation) calibrate the probe. To do this, two buffer solutions are needed: a 7.00pH buffer solution and a 4.00pH or 9.00pH buffer solution. Proceed as follows:

- 1) Measure buffer solution temperature and verify if it is the same printed on solution's label.
- 2) Insert probe's connector (blue colour) into pump's input connector.
- 3) Remove protective cap from probe and wash it into water. Then dry it.

Into "Setup" menu (fig.3), choose "2)Calib" then press "E" key. The display shows:

R: 7.20 pH
C: 7.00 pH fig.6

"R" means buffer solution reading value and "C" the calibration to refer to. During the calibration the "R" value could be different from the buffer solution value. Wait a stable reading in "R". Dip probe in a 7.00 pH buffer solution and use "UP" and "DOWN" keys to change the value in "C:" to have buffer solution value. Wait a stable reading in "R:" then press "E" key to confirm this first calibration. Pump will show:

R: 7.20 pH
C: 4.00 pH fig.7

Remove the probe from first buffer solution and repeat the cleaning procedure. Then dip probe into second buffer solution (for example 4.00 pH) and use "UP" and "DOWN" keys to change the value in "C:" to have buffer solution value. Wait a stable reading in "R:" then press "E" key to confirm. The pump will show the new values for a while and will return to main menu.

59mV / pH
- 000 mV fig.8

If calibration process fails the pump will show "PH CALIB FAILED". Not changing any value the program will return to "Calib" mode. To exit press "RIGHT" key twice.

DELAY

In main menu choose "PARAM" (fig.2) and press "E" key. Display shows:

DEL.: ->00
0 0 0 0 fig.9

The -> arrow is on "DEL". *This value is pump's waiting time after any start up procedure:* pump will wait set time before start dosing every time it is powered on. Use "UP" and "DOWN" keys to change this value. Waiting time may be set from 1 to 60 minutes.

PASSWORD

In main menu choose "PARAM" (fig.2) and press "E" key. Display shows:

DEL.: →00
0 0 0 0

fig.9

Press "RIGHT" key to move on 0 0 0 0. All new pumps have "0 0 0 0" as default password, use "UP" and "DOWN" keys to change this value. Press "E" to confirm new data. The pump shows the new password for about two seconds then it'll return to main menu. Press "RIGHT" key to leave main menu.

MAXIMUM TIME DOSING ALARM

This alarm prevents the pump to dose if a set time is reached. To set this alarm enter into "Setup menu" as shown in fig.3. Use "DOWN" key to choose "3) Alarm" and press "E" key. The pump shows:

-> AL OFF
DOSING

fig.10

To activate the alarm use "UP" or "DOWN" keys to set the time (from 1 to 100 minutes or "AL OFF"). To setup the alarm mode use the "RIGHT" key. Cursor moves on "DOSING". Use "UP" or "DOWN" keys to change this voice. On "STOP" mode the pump will stop the dosing procedure once the set time is reached. The pump's display will show the alarm condition and requires to press a key to continue. On "DOSING" mode the pump will NOT stop the dosing procedure once the set time is reached. The pump's display will show the alarm condition and requires to press a key to continue.

Special functions

- Keep pressed the "UP" key to turn off the pump. Display shows "OFF" and it will switch off. Keeping pressed the "UP" key the pump will switch on.
- Keep pressed the "DOWN" key to read on display the power supply input.
- Keep pressed the "RIGHT" key for manual dosing.
- Pump's reset: turn off the pump, keep pressed "UP" and "DOWN" keys then turn on the pump. Release "UP" and "DOWN" keys and proceed to pump's set-up. This procedure will return the pump to its shipment condition.

10. Programming the “VMS RH” pump

PROGRAMMING “VMS RH” PUMP

Turn on the pump. Keep pressed “E” key for at least 4 seconds to enter in program mode. Pump’s display shows:

PASSWORD :

→ 0000

fig.1

Use “UP” and “DOWN” keys to edit the password, press “RIGHT” to move on next digit.

“SETUP” program

Once entered the password, pump’s display shows:

→SETUP

PARAM

fig.2

Move arrow on “SETUP” then press the “E” key:

“SET POINT” program

Setup

1) Point

fig.3

Press “E”, the display will show:

a) → 100%

650mV

fig.4

The pump works at 100% of its capacity if ORP value is 650mV. Make sure that arrow is on “650mV” to change it and then use “UP” and “DOWN” keys to enter a new value. Use “RIGHT” key to move on next digit. Move arrow on 100% and change using the “UP” and “DOWN” keys.

b) → 00%

700mV

fig.5

The display shows that pump stops when ORP is 700mV. Make sure that arrow is on 700mV to change this value then use “UP” and “DOWN” keys to enter a new value. Use “RIGHT” key to move on next digit. Move arrow on 100% and change using the “UP” and “DOWN” keys. Press “E” key to confirm values and quit from programming mode. Display shows for a few seconds: DATA SAVED. Pump will change proportionally its dosing capacity between 650mV and 700mV. Now the pump will modify proportionally its own dosing capacity in range between 650mV and 700mV. In previous example pump will dose “chlorine”.

Probe calibration

To obtain a reliable measurement it is necessary (during installation) calibrate the probe. To do this, a known buffer solution is needed. Proceed as follows:

- 1) Measure buffer solution temperature and verify if it is the same printed on solution's label.
- 2) Insert probe's connector (blue color) into pump's input connector.
- 3) Remove protective cap from probe and wash it into water. Then dry it.

Into "Setup" menu (fig.3), choose "2)Calib" then press "E" key. The display shows:

R: 600 mV
C: 650 mV

fig,6

"R" means buffer solution reading value and "C" the calibration to refer to. During the calibration the "R" value could be different from the buffer solution value. Wait a stable reading in "R". Dip probe in a 650mV buffer solution and use "UP" and "DOWN" keys to change the value in "C": to have buffer solution value. Wait a stable reading in "R." then press "E" key to confirm. Display shows probe's data before to return at main menu. If calibration process fails the pump will show "MV CALIB FAILED". Not changing any value the program will return to "Calib" mode. To exit press "RIGHT" key twice.

DELAY

In main menu choose "PARAM" (fig.2) and press "E" key. Display shows:

DEL.: ->00
0 0 0 0

fig.9

The -> arrow is on "DEL". *This value is pump's waiting time after any start up procedure:* pump will wait set time before start dosing every time it is powered on. Use "UP" and "DOWN" keys to change this value. Waiting time may be set from 1 to 60 minutes.

PASSWORD

In main menu choose "PARAM" (fig.2) and press "E" key. Display shows:

DEL.: ->00
0 0 0 0

fig.9

Press "RIGHT" key to move on 0 0 0 0. All new pumps have "0 0 0 0" as default password, use "UP" and "DOWN" keys to change this value. Press "E" to confirm new data and "RIGHT" to exit from programming mode.

MAXIMUM TIME DOSING ALARM

This alarm prevents the pump to dose if a set time is reached. To set this alarm enter into "Setup menu" as shown in fig.3. Use "DOWN" key to choose "3) Alarm" and press "E" key. The pump shows:

10. Programming the pump

-> AL OFF
DOSING

fig.10

To activate the alarm use "UP" or "DOWN" keys to set the time (from 1 to 100 minutes or "AL OFF"). To setup the alarm mode use the "RIGHT" key. Cursor moves on "DOSING". Use "UP" or "DOWN" keys to change this voice. On "STOP" mode the pump will stop the dosing procedure once the set time is reached. The pump's display will show the alarm condition and requires to press a key to continue. On "DOSING" mode the pump will NOT stop the dosing procedure once the set time is reached. The pump's display will show the alarm condition and requires to press a key to continue.

Special functions

- Keep pressed the "UP" key to turn off the pump. Display shows "OFF" and it will switch off. Keeping pressed the "UP" key, the pump will switch on.
- Keep pressed the "DOWN" key to read on display the power supply input.
- Keep pressed the "RIGHT" key for manual dosing.
- Pump's reset: turn off the pump, keep pressed "UP" and "DOWN" keys then turn on the pump. Release "UP" and "DOWN" keys and proceed to pump's set up. This procedure will return the pump to its shipment condition.

PUMP'S MESSAGES

During normal operating mode, the pump may show some messages.

Message: "LOW VOLT"

Description: The pump is low voltage powered. Check main power.

Message: "HIGH VOL"

Description: The pump is high voltage powered. Check main power.

Message: "LOW LEVEL"

Description: Product to dose is near to end. Verify the tank.

Message: "STAND-BY"

Description: The pump is waiting (a specified time) to become operative. See related chapter to set this function.

Description: The pump has a N.O. contact (see the picture on page 13). When the contact closes the pump stops and shows the stand-by message until the contact will be opened.

12. Troubleshooting

Problem	Possible Cause
<p>Pump doesn't turn on.</p>	<p><i>Pump isn't powered. Connect it to main supply.</i></p> <p><i>Pump's protection fuse is broken. Replace it. See page 26 for replacement procedure.</i></p> <p><i>Pump's main board is broken. Replace it. See page 26 for replacement procedure.</i></p>
<p>Pump is not dosing and solenoid is operating.</p>	<p><i>The foot filter is obstructed. Clean it.</i></p> <p><i>Suction hose is empty. Pump must be primed. Repeat priming procedure.</i></p> <p><i>Air bubbles inside hydraulic circuit. Check valves - hoses - fittings.</i></p> <p><i>Product to dose is generating gas. Turn discharge knob and let air flow away.</i></p> <p><i>Use a self-venting pump head.</i></p>
<p>Pump is not dosing and solenoid isn't operating or slightly operating.</p>	<p><i>Crystals presence inside valves. Check them and try to dose 2-3 liters of normal water. Change valves.</i></p> <p><i>Injection valve obstructed. Change it.</i></p>

13. Fuse and main board replacement

Fuse or main board replacement is allowed to qualified personnel only. Before to operate disconnect the pump from main power and all hydraulic connections.

For fuse replacement is necessary to use a 3x16 and 3x15 screwdriver and a new fuse (same model of old one).

For main board replacement is necessary to use a 3x16 and 3x15 screwdriver and a new main board (same model of old one).

Fuse replacement procedure:

- Remove 6 screws from pump's back.
- Pull pump's back cover until it's completed separated from pump's front.
- Locate the blown fuse and replace it.
- Reassemble the pump.
- Reinsert screws.

Main board replacement procedure:

- Remove 6 screws from pump's back.
- Pull pump's back cover until it's completed separated from pump's front.
- Remove board's screws.
- Completely disconnect wires from main board and replace it. Reinsert screws.
- Reconnect wires to the main board (see enclosed picture).
- Reassemble the pump.
- Reinsert screws.

14. Main Board

VMS PH
VMS RH

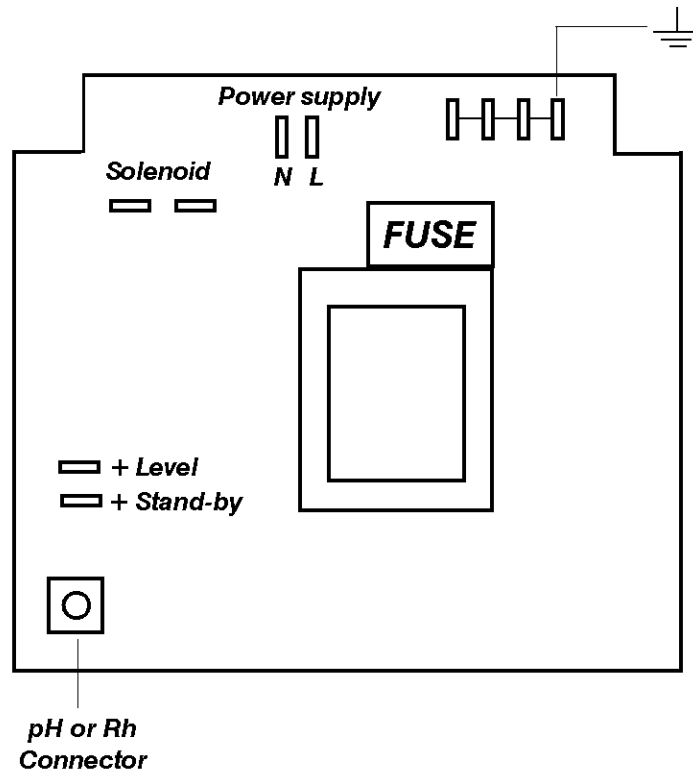

During normal operating mode, pump must be checked once for month. Wear needed safety devices and check hoses and all hydraulic components for:

- product leak
- broken hoses
- corroded connections

All maintenance operations must be performed by authorized and trained personnel only. If pump needs factory assistance please use original package to return it.

Before to do it, please, remove all dosing product inside the pump and hoses.

Use only original spare parts!

B Appendix. Construction Materials and Technical info

TECHNICAL FEATURES

Power supply:	230 VAC (180-270 VAC)
Power supply:	115 VAC (90-135 VAC)
Power supply:	24 VAC (20-32 VAC)
Power supply:	12 VDC (10-16 VDC)
Pump Strokes:	0 ÷ 180
Suction Height:	1,5 metres
Environment Temperature:	0 ÷ 45°C (32 ÷ 113°F)
Chemical Temperature:	0 ÷ 50°C (32 ÷ 122°F)
Installation Class:	II
Pollution Level:	2
Audible Noise:	74dbA
Packaging and Transporting Temperature:	-10 ÷ +50°C (14 ÷ 122°F)

MANUFACTURING MATERIALS

Case:	PPO
Pump head:	PVDF
Diaphragm:	PTFE
Balls:	CERAMIC, GLASS, PTFE, SS *
Suction Pipe	PVC
Delivery Pipe:	PE
Valve Body:	PVDF
O-ring:	FP, EP, WAX, SI, PTFE *
Injection connector	PP, PVDF (glass, HASTELLOY C276 spring)
Level Probe:	PP, PVDF *
Level probe cable:	PE
Foot Filter:	PP, PVDF *

* as ordered.

Flow	Max Capacity l/h	Max Pressure bar	ml stroke	Strokes/ min	Hoses mm	Fuse at 230 VAC	Fuse at 115 VAC	Watt ⚡	Shipping weight Kg
20 01	1	20	0.09	180	4 x 8	630 mA	315 mA	16	2.2
18 02	2	18	0.19	180	4 x 8	800 mA	500 mA	16	2.2
18 04	4	18	0.37	180	4 x 8	800 mA	630 mA	22	2.2
15 02	2	15	0.19	180	4 x 6	630 mA	315 mA	16	2.2
15 04	4	15	0.37	180	4 x 6	800 mA	500 mA	16	2.2
15 05	5	15	0.46	180	4 x 6	800 mA	630 mA	22	2.2
10 04	4	10	0.37	180	4 x 6	630 mA	315 mA	16	2.2
10 05	5	10	0.46	180	4 x 6	800 mA	500 mA	16	2.2
10 10	10	10	0.93	180	4 x 6	800 mA	630 mA	22	2.2
07 06	6	7	0.56	180	4 x 6	630 mA	315 mA	16	2.2
05 10	10	5	0.93	180	4 x 6	800 mA	500 mA	16	2.2
05 12	12	5	1.11	180	4 x 6	800 mA	630 mA	22	2.2
04 08	8	4	0.74	180	4 x 6	630 mA	315 mA	16	2.2
03 10	10	3	0.93	180	4 x 6	630 mA	315 mA	16	2.2
02 14	14	2	1.30	180	4 x 6	800 mA	500 mA	16	2.2
01 16	16	1	1.48	180	4 x 6	800 mA	500 mA	16	2.2

C Appendix. Delivery Curves

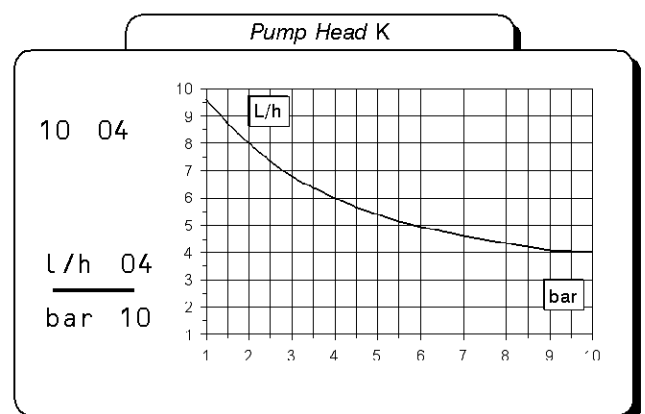
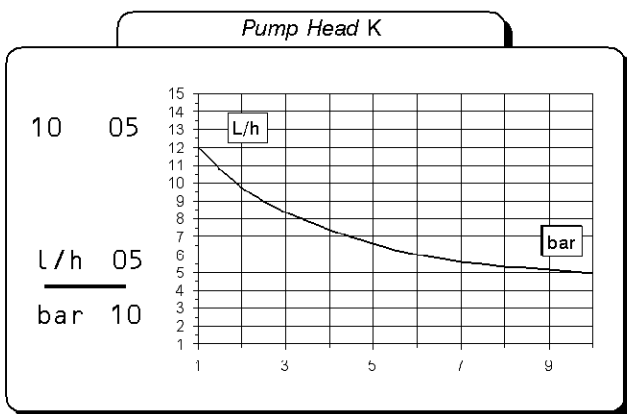
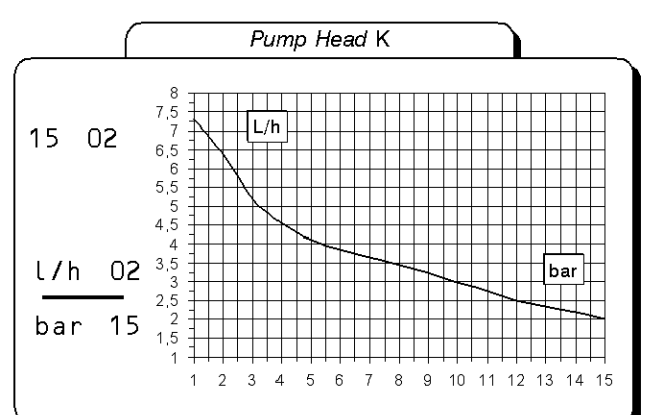
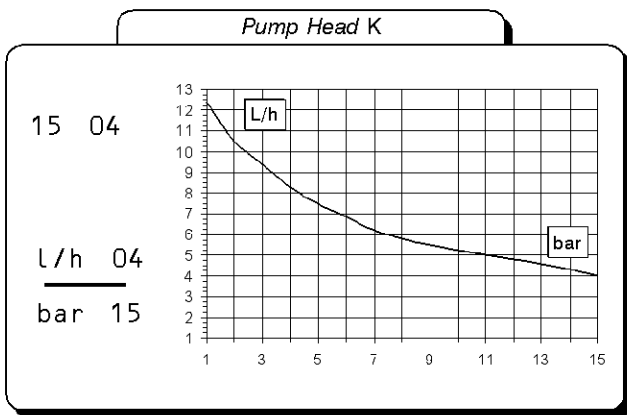
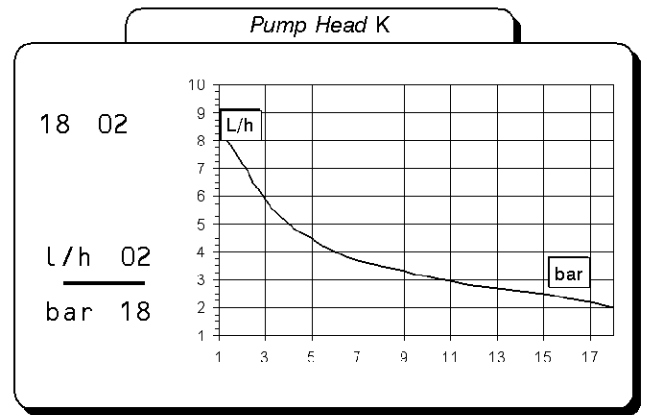
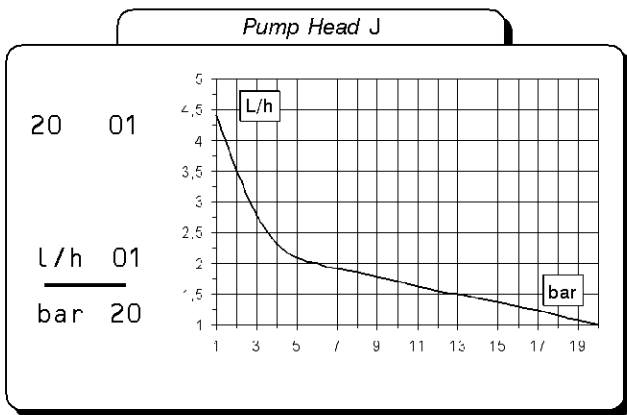

C Appendix. Delivery Curves

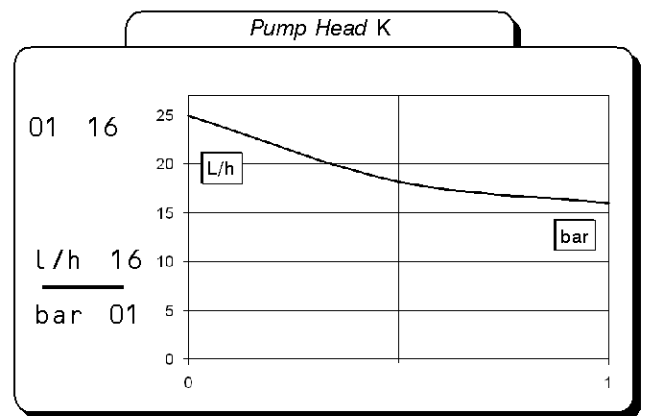
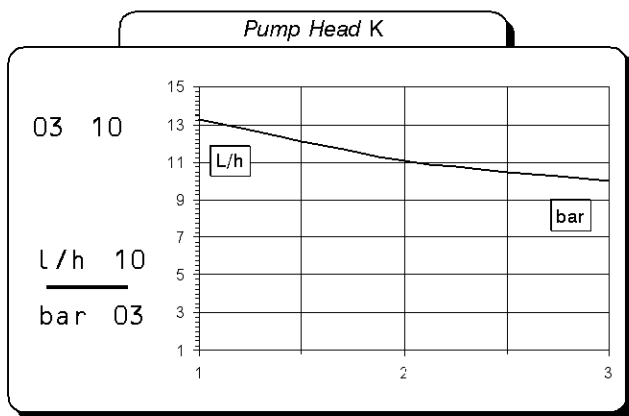
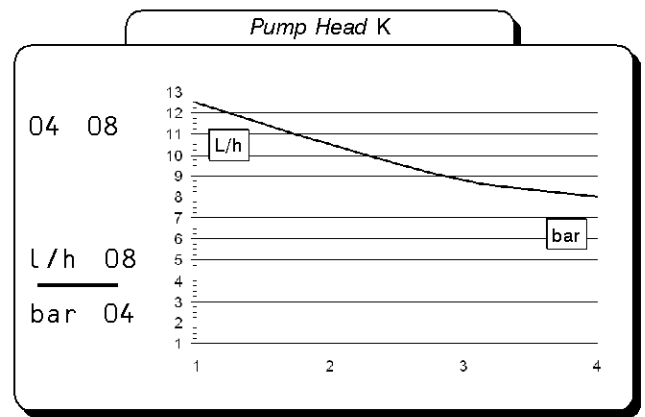
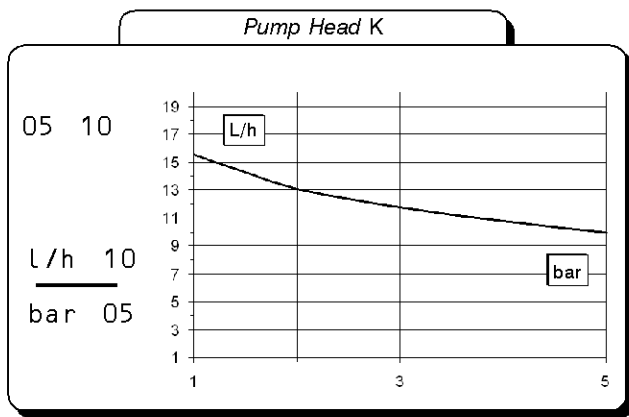

Flow rate indicated is for H₂O at 20°C at the rated pressure.

Dosing accuracy $\pm 2\%$ at constant pressure $\pm 0,5$ bar.

D Appendix. Dimensions

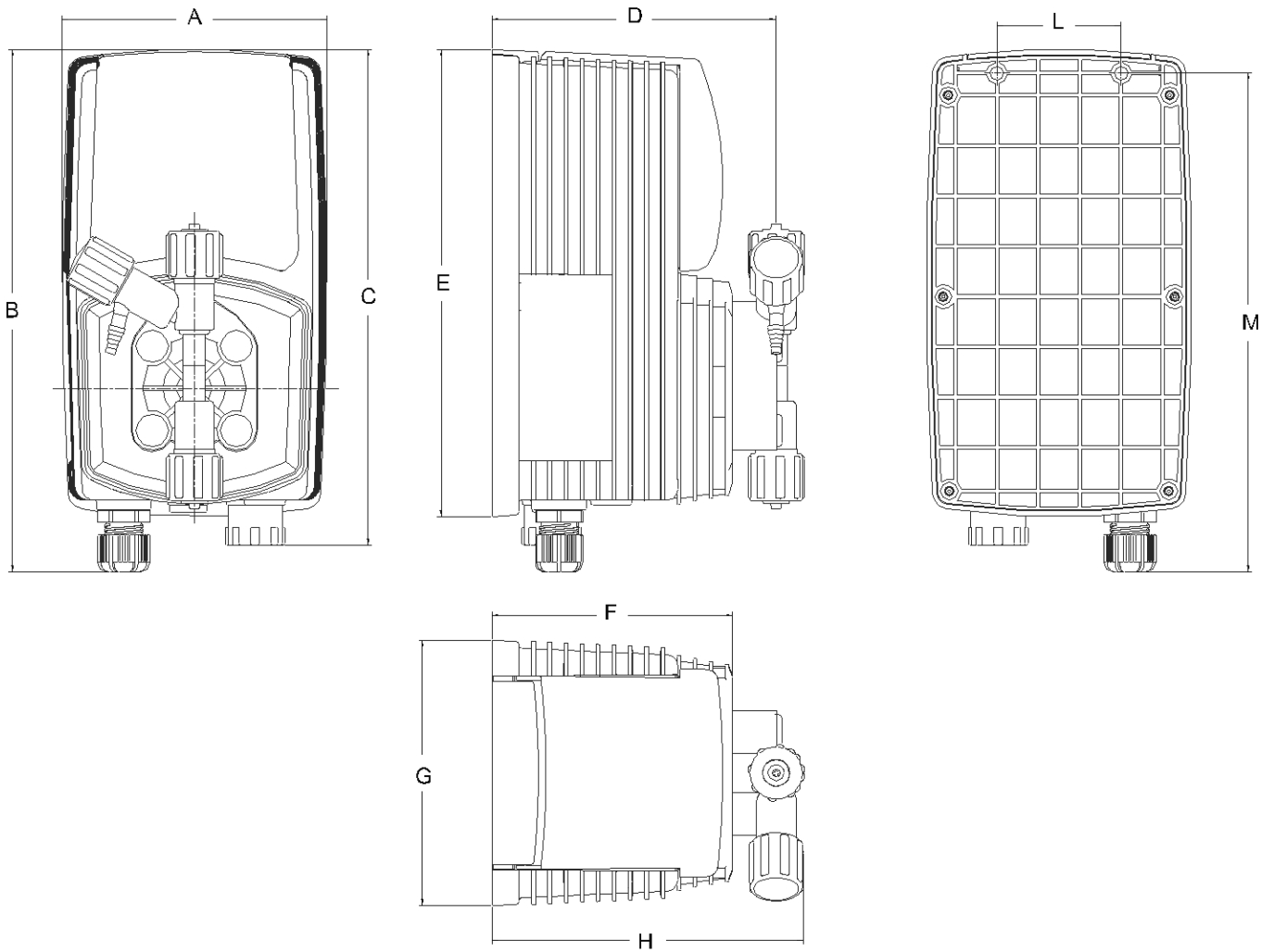

DIMENSIONS		
	<i>mm</i>	<i>inch</i>
<i>A</i>	106.96	4.21
<i>B</i>	210.44	8.28
<i>C</i>	199.44	7.85
<i>D</i>	114.50	4.50
<i>E</i>	187.96	7.40
<i>F</i>	97.00	3.81
<i>G</i>	106.96	4.21
<i>H</i>	125.47	4.93
<i>L</i>	50.00	1.96
<i>M</i>	201.00	7.91

E Appendix. Chemical Compatibility Table

Solenoid driven metering pumps are widely used to dose chemical fluids and it is important that the most suitable material in contact with fluid is selected for each application. This compatibility table serves as a useful help in this respect. All the informations in this list are verified periodically and believed to be correct on the date of issuance. All the informations in this list are based on manufacturer's data and its own experience but since the resistance of any material depends by several factors this list is supplied only as an initial guide, in no way EMEC makes warranties of any matter respect to the informations provided in this list.

Chemical	Formula	Glass	PVDF	PP	PVC	SS 316	PMMA	Hastelloy	PTFE	FPM	EPDM	NBR	PE
Acetic Acid, Max 75%	CH ₃ COOH	2	1	1	1	1	3	1	1	3	1	3	1
Aluminium Sulphate	Al ₂ (SO ₄) ₃	1	1	1	1	1	1	1	1	1	1	1	1
Amines	R-NH ₂	1	2	1	3	1	-	1	1	3	2	4	1
Calcium Hydroxide (Lime Milk)(Slaked Lime)	Ca(OH) ₂	1	1	1	1	1	1	1	1	1	1	1	1
Calcium Hypochlorite (Chlorinated Lime)	Ca(OCl) ₂	1	1	1	1	3	1	1	1	1	1	3	1
CopperII-Sulphate (Roman Vitriol)	CuSO ₄	1	1	1	1	1	1	1	1	1	1	1	1
Ferric Chloride	FeCl ₃	1	1	1	1	3	1	1	1	1	1	1	1
Hydrofluoric Acid 40%	HF	3	1	1	2	3	3	2	1	1	3	3	1
Hydrochloric Acid, Concentrate	HCl	1	1	1	1	3	1	1	1	1	3	3	1
Hydrogen Peroxide, 30% (Perydrol)	H ₂ O ₂	1	1	1	1	1	3	1	1	1	2	3	1
Nitric Acid, 65%	HNO ₃	1	1	2	3	2	3	1	1	1	3	3	2
Phosphoric Acid, 50% (Orthophosphoric Acid)	H ₃ PO ₄	1	1	1	1	2	1	1	1	1	1	3	1
Potassium Permanganate, 10%	KMnO ₄	1	1	1	1	1	1	1	1	1	1	3	1
Sodium Bisulphite	NaHSO ₃	1	1	1	1	2	1	1	1	1	1	1	1
Sodium Carbonate (Soda)	Na ₂ CO ₃	2	1	1	1	1	1	1	1	2	1	1	1
Sodium Hydroxide (Caustic Soda)	NaOH	2	1	1	1	1	1	1	1	2	1	2	1
Sodium Hypochlorite, 12.5%	NaOCl + NaCl	1	1	2	1	3	1	1	1	1	1	2	1
Sulphuric Acid, 85%	H ₂ SO ₄	1	1	1	1	2	3	1	1	1	3	3	1
Sulphuric Acid, 98.5%	H ₂ SO ₄	1	1	3	3	3	3	1	1	1	3	3	3

Resistance rating

Resistant	1
Fairly resistant	2
Not resistant	3

Materials

Polyvinylidene fluoride	PVDF	Pump Heads, valves, fitting, tubing
Polypropylene	PP	Pump Heads, valves, fitting, level floater
PVC	PVC	Pump Heads
Stainless steel	SS 316	Pump Heads, valves
Polymethyl Metacrilate (Acrylic)	PMMA	Pump Heads
Hastelloy C-276	Hastelloy	Injection valve spring
Polytetrafluoroethylene	PTFE	Diaphragm
Fluorocarbon (Viton® B)	FPM	Sealings
Ethylene propylene	EPDM	Sealings
Nitrile	NBR	Sealings
Polyethylene	PE	Tubing

F Appendix. Hoses resistance table

Hose features are very important for a reliable dosage. Every pump's model is made to work in the best way using selected hoses according to pump's capacity / model. Information reported here are intended for standard use only. For extended information ask to hose's manufacturer.

Suction / Delivery Hose			
4x6 mm PVC (transparent)	4x8 mm PE (opaque)	6x8 mm PE (opaque)	8x12 mm PVC (transparent)

Delivery Hose	Working Pressure				Breaking Pressure			
4x6 mm PE 230 (opaque)	20°C 12 bar	30°C 10.5 bar	40°C 8.5 bar	50°C 6.2 bar	20°C 36 bar	30°C 31.5 bar	40°C 25.5 bar	50°C 18.5 bar
4x8 mm PE 230 (opaque)	20°C 19 bar	30°C 15.7 bar	40°C 12 bar	50°C 7.5 bar	20°C 57 bar	30°C 47 bar	40°C 36 bar	50°C 22.5 bar
6x8 mm PE 230 (opaque)	20°C 8.6 bar	30°C 6.8 bar	40°C 4.8 bar	50°C 2.3 bar	20°C 26 bar	30°C 20.5 bar	40°C 14.5 bar	50°C 7 bar
8x12 mm PE 230 (opaque)	20°C 12 bar	30°C 10.5 bar	40°C 8.5 bar	50°C 6.2 bar	20°C 36 bar	30°C 31.5 bar	40°C 25.5 bar	50°C 18.5 bar
4x6 mm PVDF Flex 2800 (opaque)	20°C 40 bar	30°C 34 bar	40°C 30 bar	50°C 27 bar	60°C 24.8 bar	80°C 20 bar	90°C 10 bar	
6x8 mm PVDF Flex 2800 (opaque)	20°C 29 bar	30°C 25.5 bar	40°C 22 bar	50°C 20 bar	60°C 18 bar	80°C 14.5 bar	90°C 7.3 bar	
8X10 mm PVDF Flex 2800 (opaque)	20°C 18 bar	30°C 15.5 bar	40°C 13.5 bar	50°C 12.5 bar	60°C 11.2 bar	80°C 9 bar	90°C 4.5 bar	
1/4 PE 230 (opaque)	20°C 17.6 bar							
3/8 PE 230 (opaque)	20°C 10.6 bar							
1/2 PE 230 (opaque)	20°C 10.6 bar							

G Appendix. Exploded View

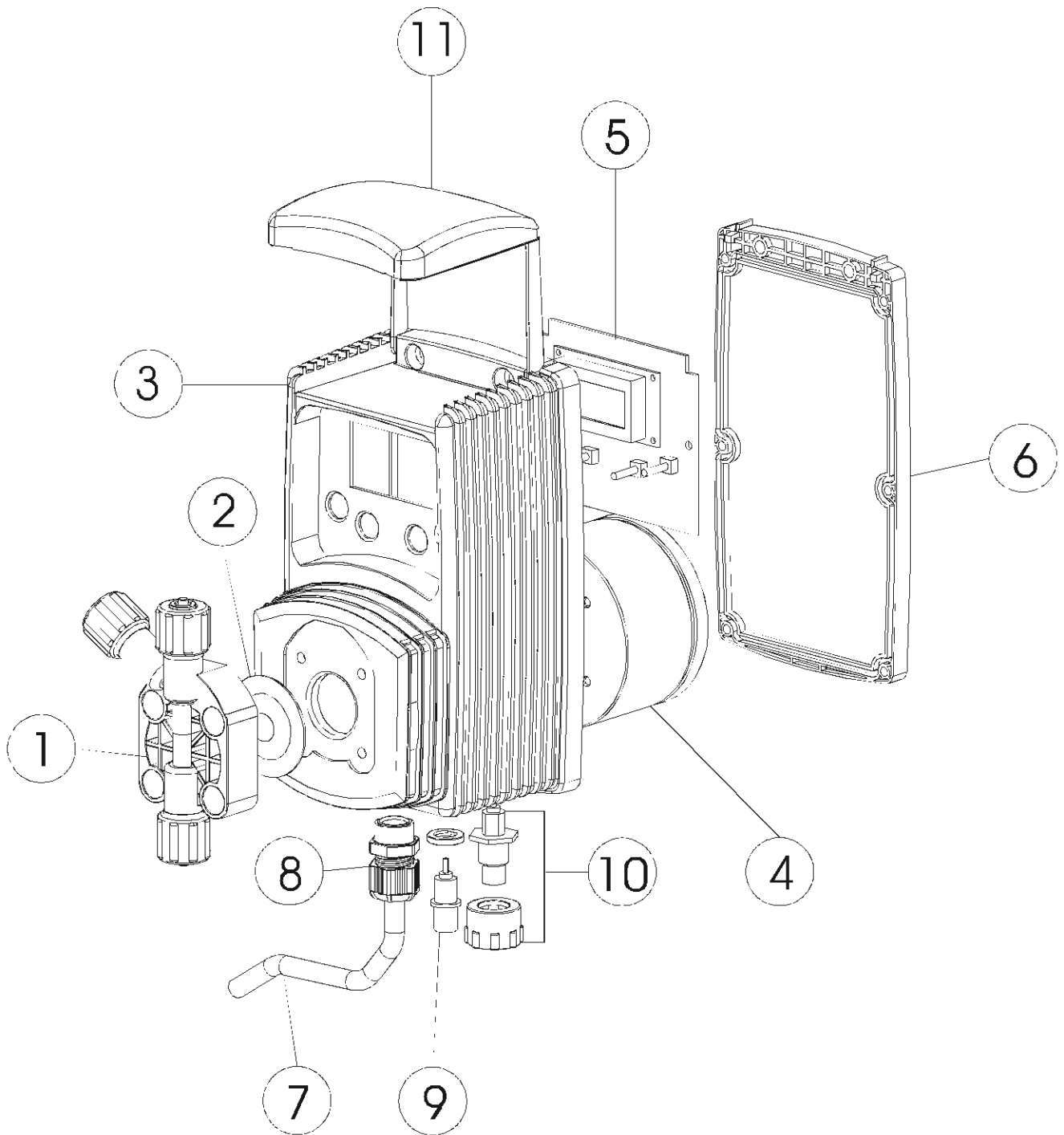

Notice: always specify the pump's label when ordering spare parts.

INDEX

1. Introduction	3
2. Unpacking	4
3. Pump's description	5
4. Before to Install warnings	6
5. Installation Draw	7
6. Hydraulic Installation	8
7. Electrical Installation	12
8. Basic Settings	14
9. Programming the "VMS PH" pump	15
10. Programming the "VMS RH" pump	18
11. Pump's messages	21
12. Troubleshooting	22
13. Fuse and main board replacement	23
14. Main Board	24
A Appendix. Maintenance.	25
B Appendix. Construction Materials and Technical info	26
C Appendix. Delivery Curves	27
D Appendix. Dimensions	29
E Appendix. Chemical Compatibility Table	30
F Appendix. Hoses resistance table	31
G Appendix. Exploded View	32
I Appendix. Index	33

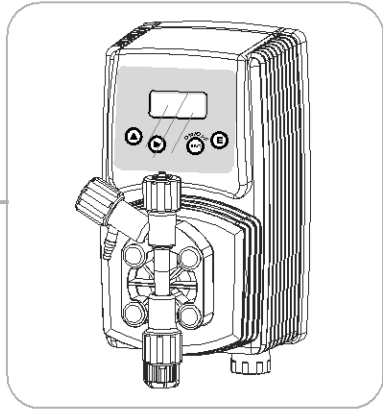

*When dismantling a pump please separate material types and send them according to local recycling disposal requirements.
We appreciate your efforts in supporting your local Recycle Environmental Program.
Working together we'll form an active union to assure the world's invaluable resources are conserved.*