

RU-509 Relay Unit







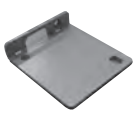

INSTALLATION MANUAL

Applied Machine: C7000/C7000P/C6000/C70hc
 COLOR PRESS: (71ppm/71ppm)/(70ppm/70ppm)/(60ppm/60ppm)
 Product Code: A1DU/A204/A1DV/A205

I. Precaution

1. Select a flat and stable place for installing the machine.
2. Lifting the machine in an awkward position or transporting it in a poorly balanced position could result in personal injury. When transporting the machine, assign an adequate number of persons to the job and ensure that each person can take a good position of not being excessively loaded. (mass: approx. 60 kg)

II. Accessory parts

No.	Name	Shape	Q'ty
1.	Installation plate /1	 A1TTIXC002CA	2
2.	Installation plate /2	 A2A2IXC001CA	2
3.	Installation plate /3	 A1TTIXC004CA	2
4.	Clamp	 A1TTIXC005CA	1
5.	TP screw M4x6		8
6.	TP screw M4x8		2
7.	Sems II screw M4x8		1
8.	Installation manual		1
9.	Power cord (Except for Europe)		1

III. Installation Procedure

1. Remove the mirror mat and the locking tapes from the external parts.
2. Check the external appearance of the machine.

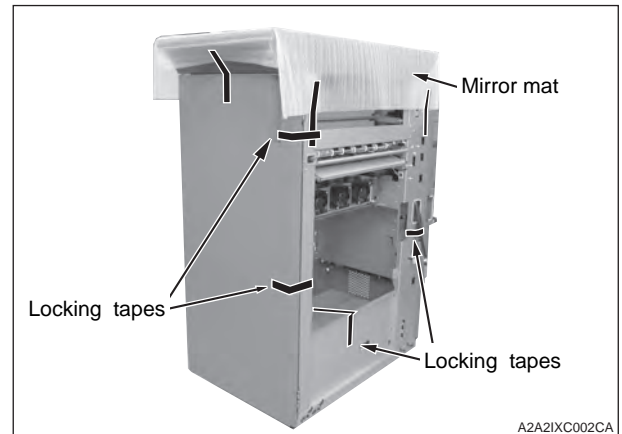

3. Open the front door and remove the locking tapes and the bundled item.

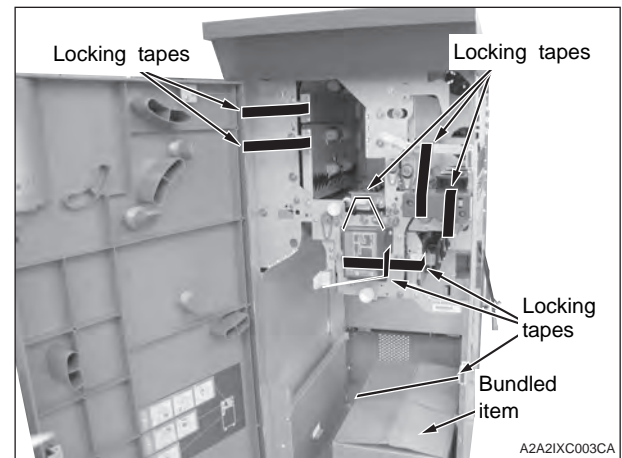

4. Remove the connector cover on the left side of the main body. (1 screw)

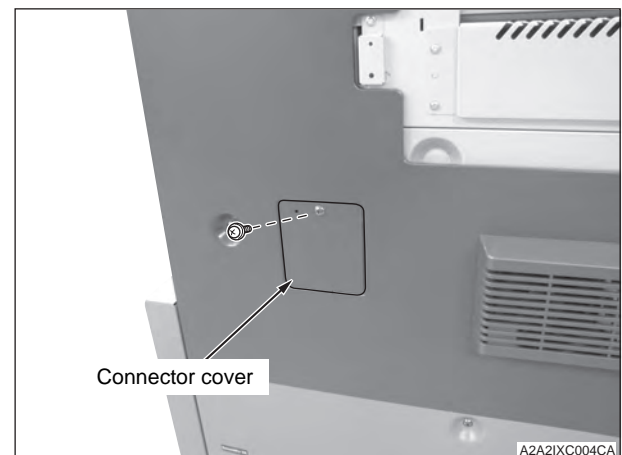

5. Install the installation plates /1 and /2 to the main body. (each 2 places: TP screw M4x6: each 2 pcs)

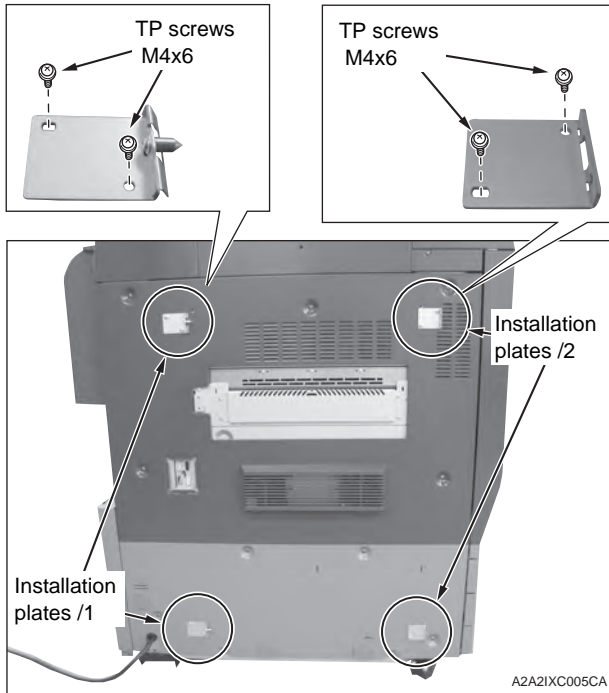

6. Connect 4 connectors of the RU-509 to the connectors of the main body.

Note:

Before setting the RU connector wiring harness to the main body, be sure to push it into the RU side. Otherwise it is nipped.

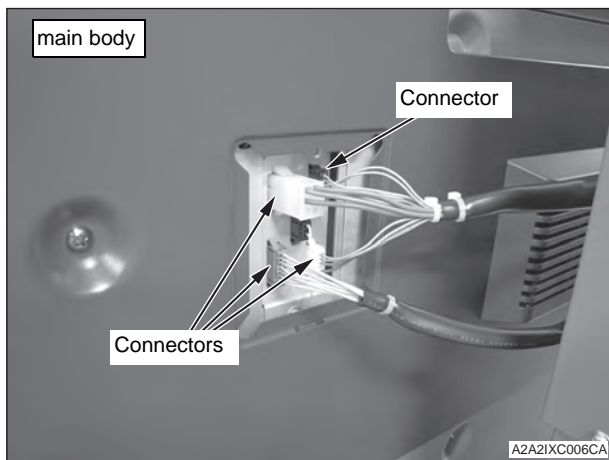

7. Adjust the height of the RU-509.

(1) Align the height of the main body and RU-509 as shown in the picture.

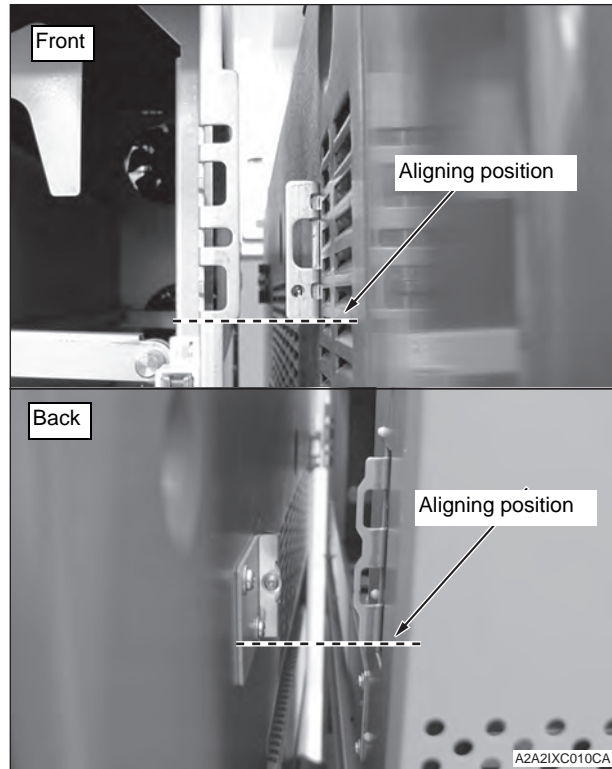

Note:

- Turn 4 height adjustment screws (back and front) shown in the picture to adjust the height.
- Turning the screw clockwise rises the RU.

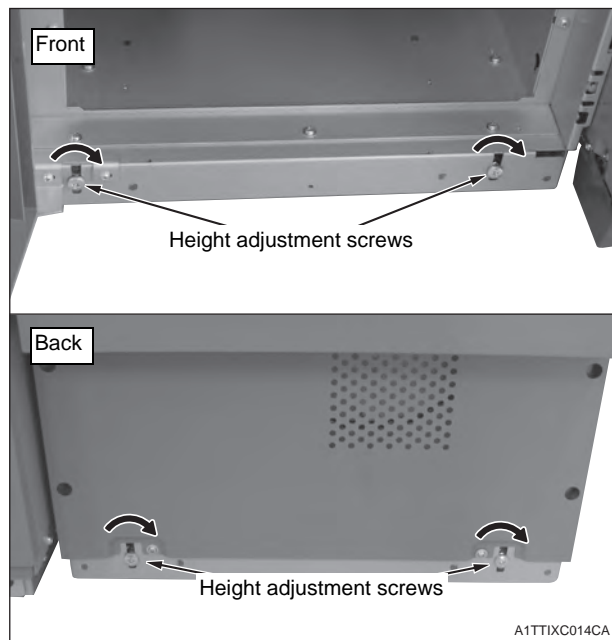

8. Align the top and bottom holes of the RU-509 to the installation plates /1 pins, and lock them by sliding the RU-509 to the back.

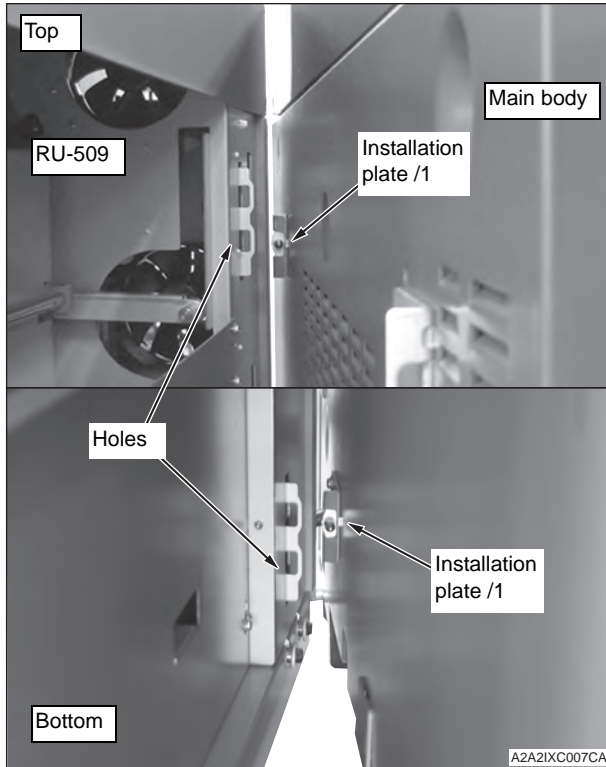

9. Fix the RU-509 and the installation plates /3 with the screws. (TP screw M4x8: 2)

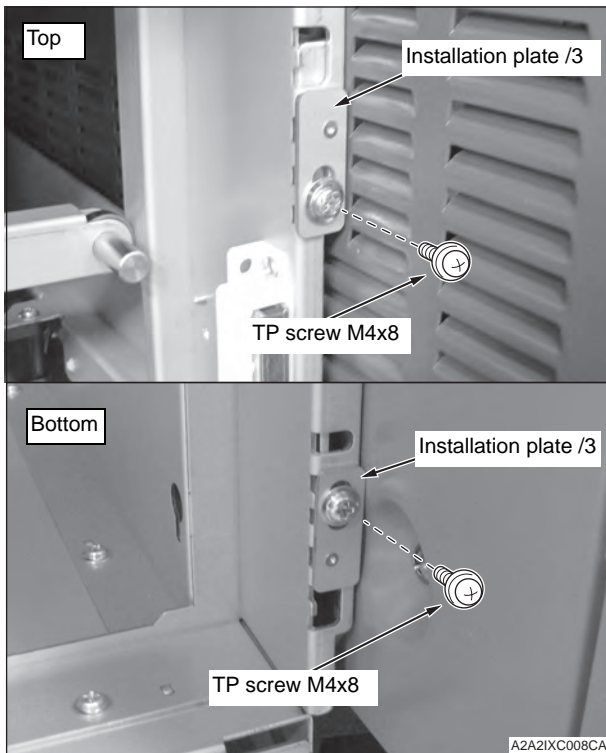

10. Plug in the RU-509 power cord and fix it in the clamp. (Sems II screw M4x8 : 1)

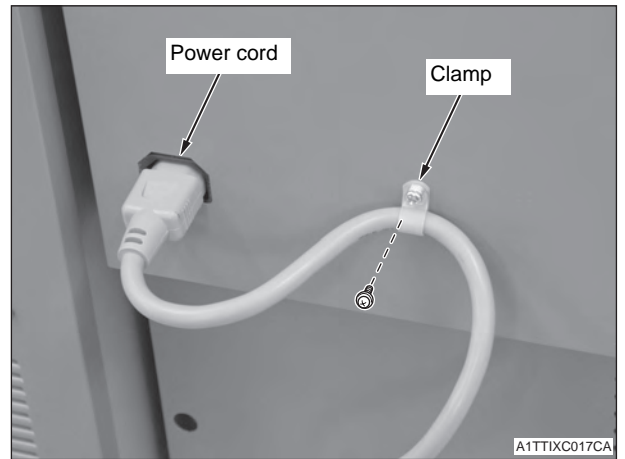

IV. Serial Number Registration

Register the serial number of the RU-509 installed to the main body

The location of the serial number is shown in the figure below.

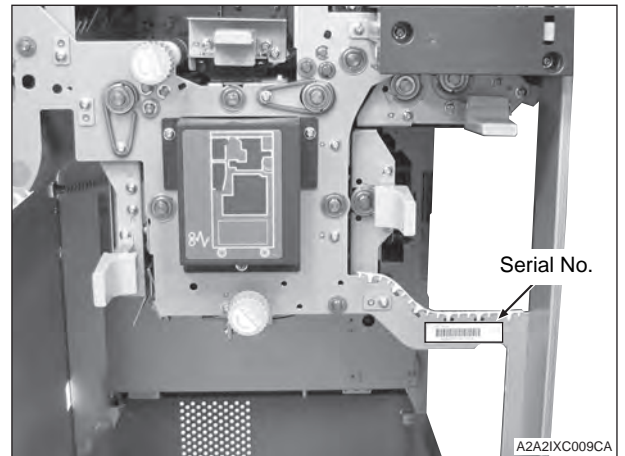

	Step
1.	Plug the power cord of the main body and the RU-509 into the outlet and turn ON the Main power switch.
2.	Enter Service mode. Note: Refer to procedures in the Service Manual to enter into the Service Mode.
3.	Touch the "System Setting" key.
4.	Touch the "Serial Number Setting" key.
5.	Touch the "Finisher" key to enter the serial number setting screen. (Select the installation order key.)
6.	Enter the serial number of the RU-509 and touch the "OK" key. (Use the "Shift" key to switch between upper case letters and lower case letters.)
7.	Touch the "Return" key and then touch the "Exit" key.