

STRUCTURAL AND FUNCTIONAL PARTS (1)

PCA-RP50KA

PCA-RP100KA

PCA-RP60KA

PCA-RP125KA

PCA-RP71KA

PCA-RP140KA

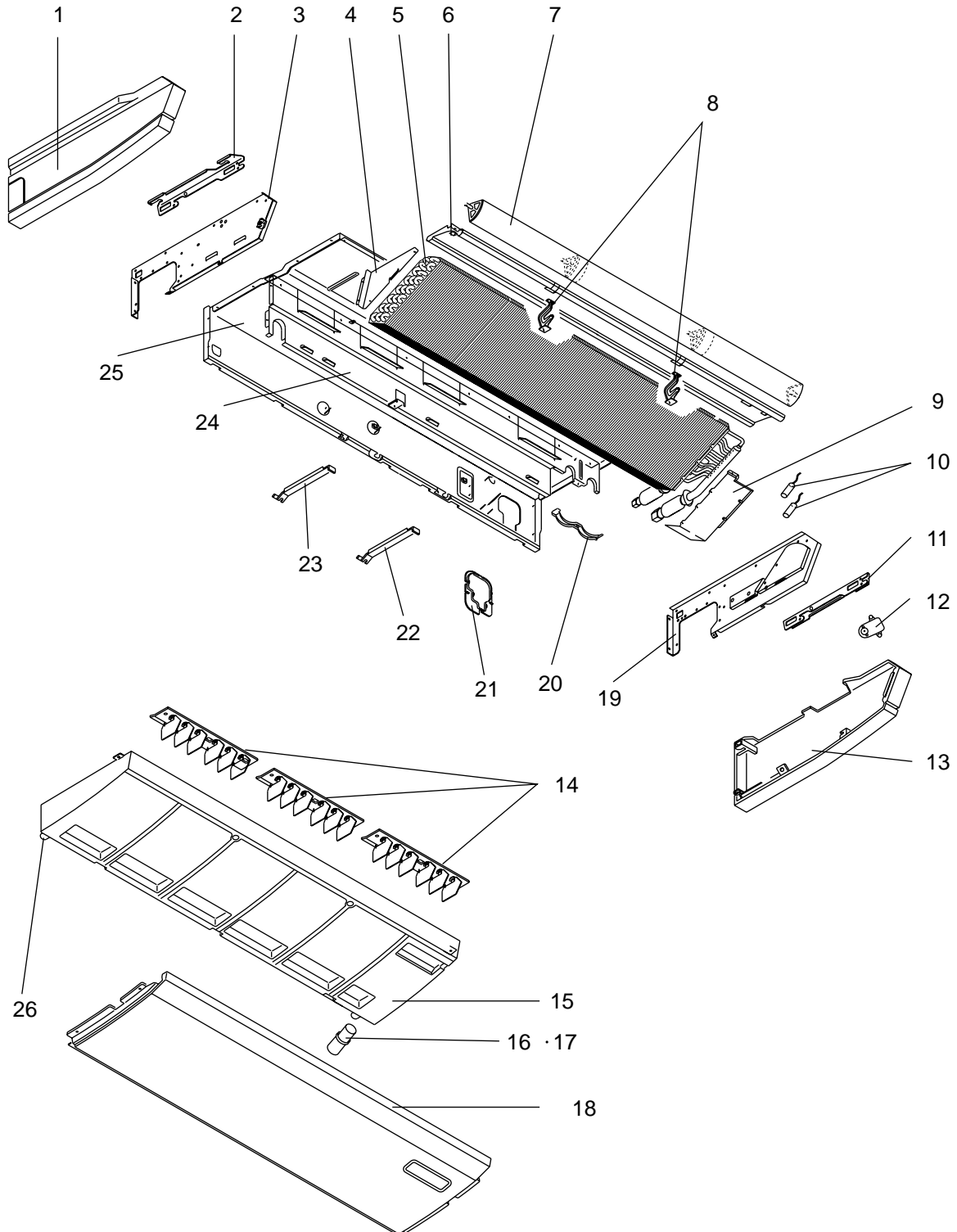



No.	R/HS	Part No.	Part Name	Specification	Q'ty/set						Remarks (Drawing No.)	Wiring Diagram Symbol	Recom- mended Q'ty
					PCA-RP-KA								
					50	60	71	100	125	140			
1	G	R01 E26 662	SIDE PANEL-L		1	1	1	1	1	1			
2	G	R01 E06 809	LEG-L		1	1	1	1	1	1			
3	G	R01 E02 666	SIDE PLATE-L		1	1	1	1	1	1			
4	G	R01 E05 615	COIL SUPPORT-H		1	1	1	1	1				
	G	R01 E06 615	COIL SUPPORT-H							1			
5	G	T7W N06 480	HEAT EXCHANGER		1								
	G	T7W N07 480	HEAT EXCHANGER			1							
	G	R01 N50 480	HEAT EXCHANGER				1						
	G	R01 N51 480	HEAT EXCHANGER					1					
	G	R01 N52 480	HEAT EXCHANGER						1				
6	G	R01 N53 480	HEAT EXCHANGER							1			
	G	R01 E12 651	FRONT PANEL		1								
	G	R01 E13 651	FRONT PANEL			1	1						
7	G	R01 E14 651	FRONT PANEL					1	1	1			
	G	R01 E28 002	AUTO VANE		1								
	G	R01 E29 002	AUTO VANE			1	1						
8	G	R01 E30 002	AUTO VANE					1	1	1			
	G	R01 E04 033	VANE SUPPORT		1	2	2	2	2	2			
9	G	R01 E04 615	COIL SUPPORT		1	1	1	1	1	1			
10	G	T7W E61 202	THERMISTOR (PIPE)		1	1	1	1	1	1		TH2/TH5	
11	G	R01 E06 808	LEG-R		1	1	1	1	1	1			
12	G	R01 E25 223	VANE MOTOR ASSY		1	1	1	1	1	1		MV	
13	G	R01 E45 661	SIDE PANEL-R		1	1	1	1	1	1			
14	G	R01 E03 085	GUIDE VANE		2	3	3	3					
	G	R01 E04 085	GUIDE VANE						3	3			
15	G	R01 E42 529	DRAIN PAN		1								
	G	R01 E43 529	DRAIN PAN			1	1						
	G	R01 E44 529	DRAIN PAN					1	1	1			
16	G	R01 18J 523	JOINT SOCKET		1	1	1	1	1	1			
17	G	R01 18J 072	DRAIN HOSE COVER		1	1	1	1	1	1			
18	G	R01 E03 669	UNDER PANEL		1								
	G	R01 E04 669	UNDER PANEL			1	1						
	G	R01 E05 669	UNDER PANEL					1	1	1			
19	G	R01 E02 665	SIDE PLATE-R		1	1	1	1	1	1			
20	G	R01 E02 126	PIPE BAND		1	1	1	1	1	1			
21	G	R01 E00 053	PIPE HOLE COVER		1	1	1	1	1	1			
22	G	-	BEAM		1	1	1	1	1	1	(RG00D440G02)		
23	G	-	BEAM			1	1	1	1	1	(BH02G431G10)		
24	G	-	FAN PLATE		1						(RG00V683G56)		
	G	-	FAN PLATE			1	1				(RG00V683G57)		
	G	-	FAN PLATE					1	1	1	(RG00V683G61)		
25	G	-	BASE	Including REAR PANEL	1						(RG00V682G48)		
	G	-	BASE			1	1				(RG00V682G49)		
	G	-	BASE					1	1	1	(RG00V682G43)		
26	G	R01 18J 524	DRAIN PLUG		1	1	1	1	1	1			

STRUCTURAL AND FUNCTIONAL PARTS (2)

PCA-RP50KA

PCA-RP100KA

PCA-RP60KA

PCA-RP125KA

PCA-RP71KA

PCA-RP140KA

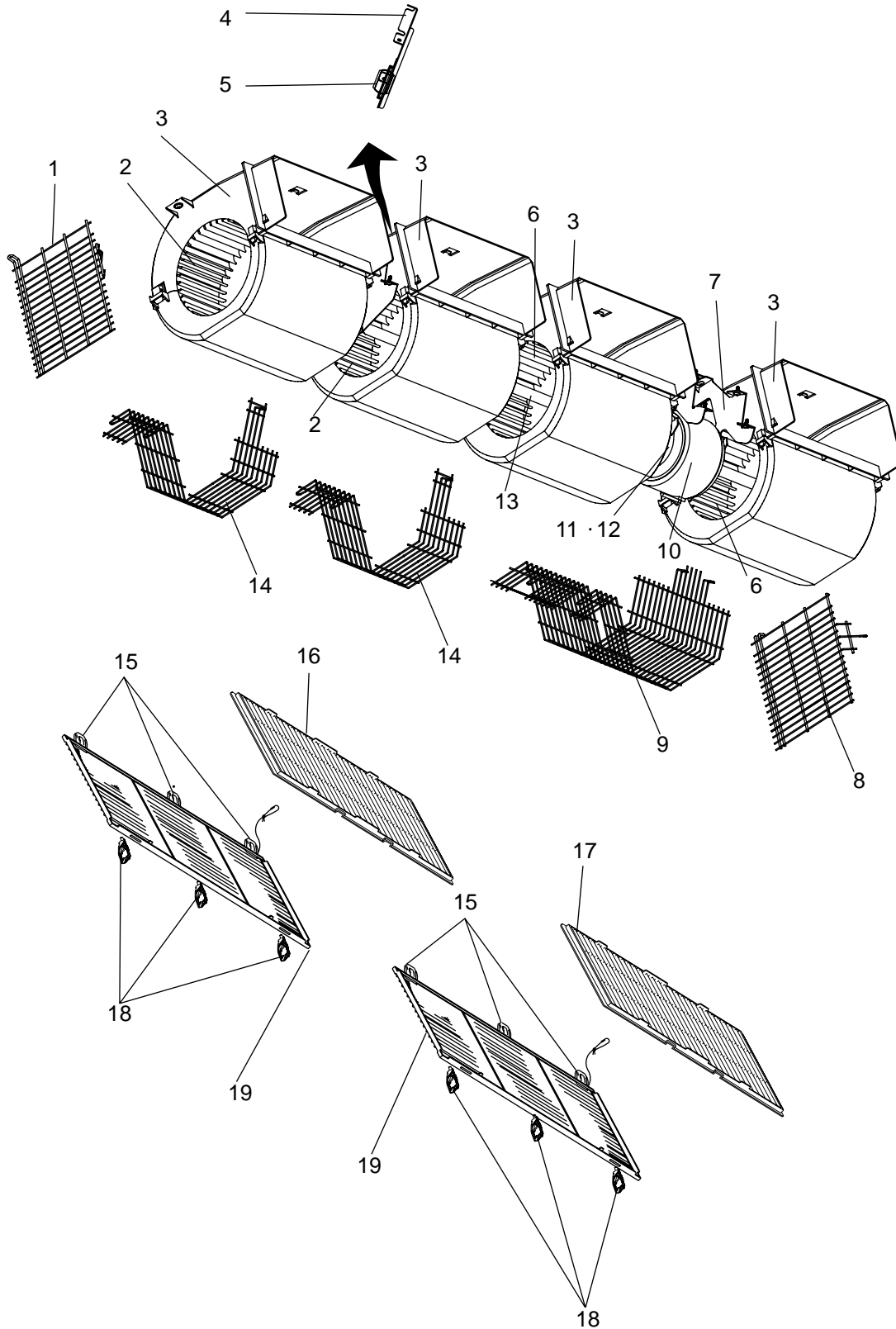

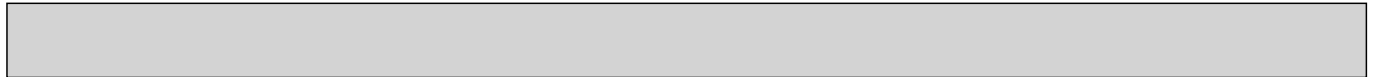

No.	RoHS	Part No.	Part Name	Specification	Q'ty/set			Remarks (Drawing No.)	Wiring Diagram Symbol	Recom- mended Q'ty
					PCA-RP-KA					
					50	60, 71	100,125,140			
1	G	T7W E20 675	FAN GUARD-L		1	1	1			
2	G	R01 E41 114	SIROCCO FAN				2			
3	G	R01 20J 110	CASING		2	3	4			
4	G	R01 E00 145	BEARING SUPPORT			1	1			
5	G	R01 E05 103	BEARING			1	1			
6	G	R01 E40 114	SIROCCO FAN		2	3	2			
7	G	T7W E16 130	MOTOR LEG		1	1	1			
8	G	T7W E21 675	FAN GUARD-R		1	1	1			
9	G	T7W E22 675	FAN GUARD		1					
	G	T7W E23 675	FAN GUARD			1	1			
10	G	T7W E38 762	FAN MOTOR		1				MF	
	G	T7W E39 762	FAN MOTOR			1			MF	
	G	T7W E40 762	FAN MOTOR				1		MF	
11	G	T7W E02 126	PIECE (MOTOR) R.L		1	1	1			
12	G	R01 E00 116	JOINT(SHAFT)			1	1			
13	G	R01 31J 100	SHAFT			1				
	G	R01 32J 100	SHAFT				1			
14	G	T7W E24 675	FAN GUARD			1				
	G	T7W E25 675	FAN GUARD				2			
15	G	R01 E04 061	GRILLE HINGE		4	5	6			
16	G	R01 E24 500	AIR FILTER		2	1				
17	G	R01 E25 500	AIR FILTER			1	2			
18	G	R01 E11 054	GRILLE CATCH		4	5	6			
19	G	R01 E54 691	GRILLE (SMALL)		2	1				
	G	R01 E55 691	GRILLE (LARGE)			1	2			

ELECTRICAL PARTS

PCA-RP50KA

PCA-RP100KA

PCA-RP60KA

PCA-RP125KA

PCA-RP71KA

PCA-RP140KA

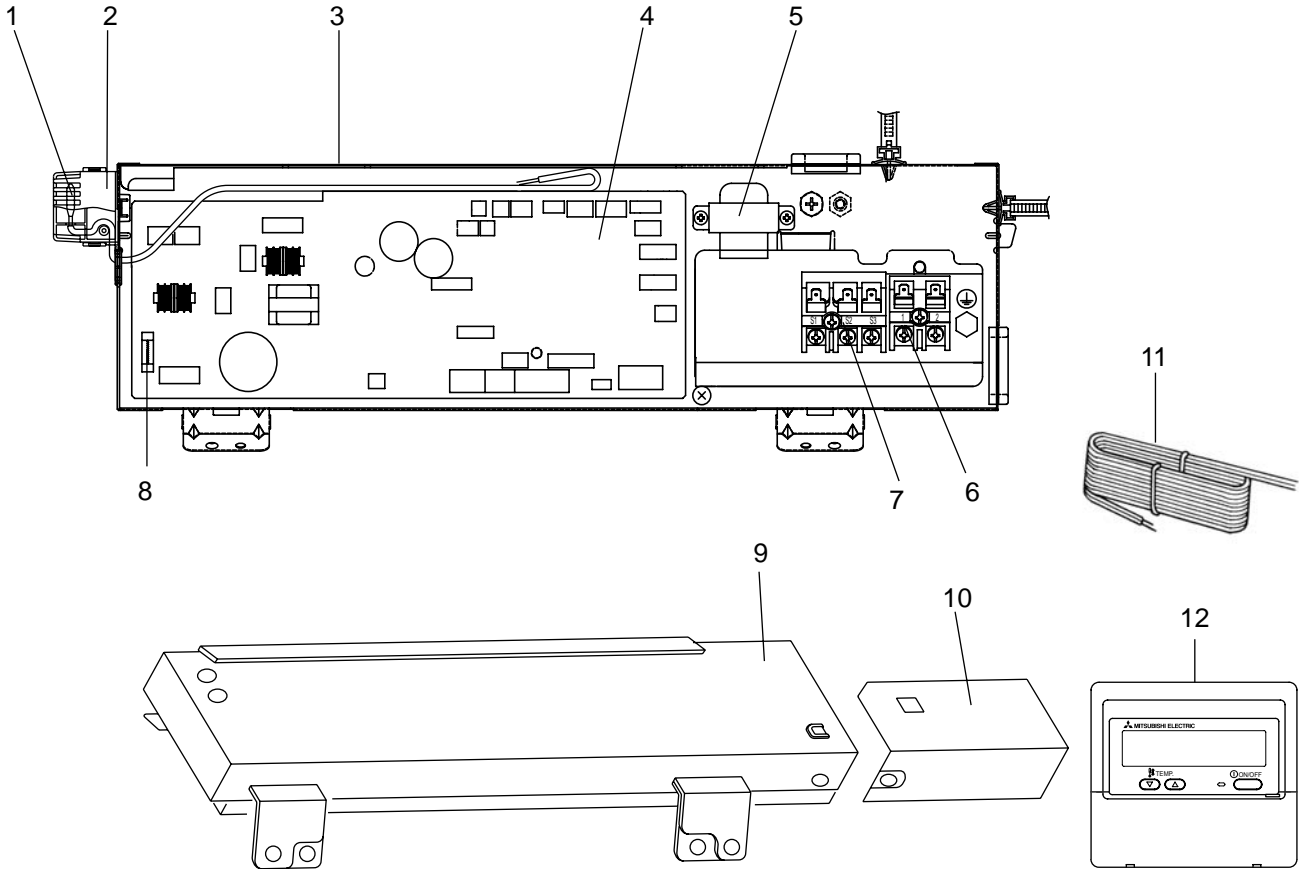

No.	RoHS	Part No.	Part Name	Specification	Q'ty/set	Remarks (Drawing No.)	Wiring Diagram Symbol	Recom- mended Q'ty
					PCA-RP-KA 50, 60, 71, 100, 125, 140			
1	G	R01 N18 202	THERMISTOR (ROOM)		1		TH1	
2	G	-	SENSOR COVER		1	(RG25V835G02)		
3	G	-	ELECTRICAL BOX		1	(BH00G997G19)		
4	G	T7W E88 310	CONTROLLER BOARD		1		I.B.	
5	G	T7W E19 259	REACTOR		1		DCL	
6	G	T7W E33 716	TERMINAL BLOCK	2P (1,2)	1		TB5	
7	G	R01 E20 246	TERMINAL BLOCK	3P (S1, S2, S3)	1		TB4	
8	G	R01 E14 239	FUSE	6.3A 250V	1		FUSE	
9	G	-	ELECTRICAL BOX COVER		1	(BH00L420G16)		
10	G	-	ELECTRICAL BOX COVER		1	(RG02V755G02)		
11	G	T7W E05 305	REMOTE CONTROLLER CORD		1			
12	G	T7W E11 713	REMOTE CONTROLLER	PAR-21MAA	1		R.B	