



Mbox[®] User Guide

Version 8.0.4

Legal Notices

This guide is copyrighted ©2010 by Avid Technology, Inc., (hereafter "Avid"), with all rights reserved. Under copyright laws, this guide may not be duplicated in whole or in part without the written consent of Avid.

003, 96 I/O, 96i I/O, 192 Digital I/O, 192 I/O, 888|24 I/O, 882|20 I/O, 1622 I/O, 24-Bit ADAT Bridge I/O, AudioSuite, Avid, Avid DNA, Avid Mojo, Avid Unity, Avid Unity ISIS, Avid Xpress, AVoption, Axiom, Beat Detective, Bomb Factory, Bruno, C|24, Command|8, Control|24, D-Command, D-Control, D-Fi, D-fx, D-Show, D-Verb, DAE, Digi 002, DigiBase, DigiDelivery, Digidesign, Digidesign Audio Engine, Digidesign Intelligent Noise Reduction, Digidesign TDM Bus, DigiDrive, DigiRack, DigiTest, DigiTranslator, DINR, D-Show, DV Toolkit, EditPack, Eleven, HD Core, HD Process, Hybrid, Impact, Interplay, LoFi, M-Audio, MachineControl, Maxim, Mbox, MediaComposer, MIDI I/O, MIX, MultiShell, Nitris, OMF, OMF Interchange, PRE, ProControl, Pro Tools M-Powered, Pro Tools, Pro Tools|HD, Pro Tools LE, QuickPunch, Recti-Fi, Reel Tape, Reso, Reverb One, ReVibe, RTAS, Sibelius, Smack!, SoundReplacer, Sound Designer II, Strike, Structure, SYNC HD, SYNC I/O, Synchronic, TL Aggro, TL AutoPan, TL Drum Rehab, TL Everyphase, TL Fauxlдер, TL In Tune, TL MasterMeter, TL Metro, TL Space, TL Utilities, Transfuser, Trillium Lane Labs, Vari-Fi Velvet, X-Form, and XMON are trademarks or registered trademarks of Avid Technology, Inc. Xpand! is Registered in the U.S. Patent and Trademark Office. All other trademarks are the property of their respective owners.

Product features, specifications, system requirements, and availability are subject to change without notice.

Guide Part Number 9329-65002-00 REV B 06/10

Documentation Feedback

At Avid, we are always looking for ways to improve our documentation. If you have comments, corrections, or suggestions regarding our documentation, email us at **techpubs@avid.com**.

contents

Chapter 1. Welcome to Mbox	1
Mbox Features	1
Pro Tools LE Capabilities	2
System Requirements and Compatibility	2
Conventions Used in This Guide	3
About www.avid.com	4
Chapter 2. Installing Pro Tools on Mac	5
Installation Overview	5
Installing Pro Tools LE and Connecting Your Interface	5
Launching Pro Tools LE	7
Additional Software on the Pro Tools Installer Disc	8
Uninstalling Pro Tools	9
Chapter 3. Installing Pro Tools on Windows	11
Installation Overview	11
Installing Pro Tools LE and Connecting Your Interface	11
Launching Pro Tools LE	14
Additional Software on the Pro Tools Installer Disc	14
Uninstalling Pro Tools	15
Chapter 4. Configuring Your Pro Tools System	17
Starting Up or Shutting Down Your System	17
Configuring Pro Tools LE	18
Configuring the Pro Tools Hardware Settings	23
Optimizing a Mac System for Pro Tools	25
Optimizing a Windows System for Pro Tools	27

Chapter 5. Mbox Hardware Overview	31
Mbox Front Panel Features	31
Mbox Back Panel Features	34
Chapter 6. Making Hardware Connections	37
Connecting Headphones	37
Connecting a Sound System	37
Connecting Audio Inputs	38
Connecting a Microphone	39
Connecting Instruments to the Mbox	40
MIDI Connections	42
Appendix A. Using the Driver Control Panel	43
Presets	44
Layouts	44
Additional Functions	46
Stereo Mixes	50
Using the Stereo Mix Section	51
Appendix B. Using the Multi Button	55
Using the Multi Button	55
Press and Release Options	56
Press and Hold Options	57
Hold Duration Options	58
Appendix C. Configuring AMS (Mac OS X Only)	59
Audio MIDI Setup	59
MIDI Patch Name Support	62
Appendix D. Configuring MIDI Studio Setup (Windows Only)	63
MIDI Studio Setup	63
MIDI Patch Name Support	65

Appendix E. Hard Drive Configuration and Maintenance	67
Avoid Recording to the System Drive	67
Supported Drive Formats and Drive Types	67
Formatting an Audio Drive	68
Partitioning Drives	69
Defragmenting an Audio Drive	70
Using Mac Drives on Windows Systems	71
Hard Disk Storage Space	72
Appendix F. Troubleshooting	73
Backing Up Your Work	73
Common Issues	73
Performance Factors	74
Before You Call Avid Support	75
Appendix G. Resources	77
About the Pro Tools Guides	77
Appendix H. Compliance Information	79
Environmental Compliance	79
EMC (Electromagnetic Compliance)	80
Safety Compliance	80
Index	83

chapter 1

Welcome to Mbox

Welcome to the Mbox[®] audio and MIDI production system from Avid[®].

Mbox and Pro Tools LE[®] provide your USB 2.0-equipped computer with two channels of analog audio input and output, two channels of digital audio input and output, MIDI In and Out ports, analog monitor outs, and a headphone output with front panel level control. Mbox provides professional-quality mic preamps and 24-bit/96 kHz analog-to-digital and digital-to-analog converters.

Mbox Features

Mbox provides the following:

- Two channels of analog audio input with high-quality microphone preamps and switchable 48V phantom power
 - Analog input jacks include two XLR/TRS combo-jacks and two 1/4 TS jacks, with switchable Mic, Line, and DI levels
 - Soft-limit feature on each input
 - -20 dB pad available separately on each analog input channel
- Two channels of S/PDIF digital input and output
 - S/PDIF inputs are available independently, in addition to analog inputs 1–2
 - S/PDIF outputs mirror analog outs 1–2 and can also work independent of the analog outputs
- Up to a total of four channels of input, using analog and digital inputs simultaneously
- One MIDI In and one MIDI Out port, providing 16 MIDI input channels and 16 MIDI output channels
- Two 1/4-inch TRS analog monitor outputs
- 24-bit A/D and D/A converters, supporting sample rates up to 96 kHz
- Low Latency Monitoring (LLM) with adjustable balance between input and playback
- Dim and Mono buttons
- 1/4-inch (TRS) stereo headphone output with adjustable level control
- On-board reverb and delay effects (useful for monitoring while tracking vocals)
- Soft-limit analog function
- On-board Tuner
- Multi-function, assignable Soft button
- USB 2.0 High-speed operation



Mbox will not function properly if connected to a passive USB hub. If you need to use a hub for other USB peripherals, use a powered hub or a separate dedicated USB port for Mbox to function properly.

Pro Tools LE Capabilities

Pro Tools LE on Mac or Windows provides the following capabilities with Mbox:

- Playback of up to 48 mono or stereo digital audio tracks, or a combination of playing back *and* recording up to 48 mono or stereo digital audio tracks, depending on the capabilities of your computer.
- Up to 128 audio tracks (with up to 48 active tracks), 128 Auxiliary Input tracks, 64 Master Fader tracks, 256 MIDI tracks, and 32 Instrument tracks per session.
- 16-bit or 24-bit audio resolution, at sample rates up to 96 kHz.
- Non-destructive, random-access editing and mix automation.
- Audio processing with up to 10 inserts per track (RTAS® plug-ins or hardware inserts)
- Up to 10 sends per track.
- Up to 32 internal mix busses.

⚠ *Pro Tools LE uses your computer's CPU to mix and process audio tracks (host processing). Computers with faster clock speeds yield higher track counts and more plug-in processing.*

System Requirements and Compatibility

Mbox can be used with a qualified Windows or Mac computer running Pro Tools LE software.

A DVD drive is required to use the Pro Tools Installer disc.

Avid can only assure compatibility and provide support for hardware and software it has tested and approved.

For complete system requirements and a list of qualified computers, operating systems, hard drives, and third-party devices, visit:

www.avid.com/compatibility

MIDI Requirements

Mbox includes one MIDI In port and one MIDI Out port, providing 16 channels of MIDI input and 16 channels of MIDI output.

If you require additional MIDI ports, add a MIDI interface to your system.

USB MIDI interfaces work effectively with Pro Tools systems on Windows or Mac. Serial MIDI interfaces are supported on Windows systems only.

⚠ *Only USB MIDI interfaces are compatible with Pro Tools systems for Mac OS X. Modem-to-serial port adapters and serial MIDI devices are not supported.*

For a list of supported MIDI interfaces and controllers, visit www.avid.com.

Hard Drive Requirements

For optimal audio recording and playback, all Pro Tools systems require one or more qualified drives.

If you are using an ATA/IDE or FireWire hard drive, initialize your drive with the Disk Utility application included with Apple System software (Mac) or the Windows Disk Management (Windows).

 *For more information, see Appendix E, “Hard Drive Configuration and Maintenance.”*

Avoid Recording to the System Drive

Recording to your system drive is not recommended. Recording and playback on a system drive may result in lower track counts and fewer plug-ins.

Conventions Used in This Guide

All of our guides use the following conventions to indicate menu choices and key commands:

Convention	Action
File > Save	Choose Save from the File menu
Control+N	Hold down the Control key and press the N key
Control-click	Hold down the Control key and click the mouse button
Right-click	Click with the right mouse button

The names of Commands, Options, and Settings that appear on-screen are in a different font.

The following symbols are used to highlight important information:

 *User Tips are helpful hints for getting the most from your system.*

 *Important Notices include information that could affect your data or the performance of your system.*

 *Shortcuts show you useful keyboard or mouse shortcuts.*

 *Cross References point to related sections in this guide and other Pro Tools guides.*

About www.avid.com

The Avid website (www.avid.com) is your best online source for information to help you get the most out of your Pro Tools system. The following are just a few of the services and features available.

Product Registration Register your purchase online.

Support and Downloads Contact Avid Customer Success (technical support); download software updates and the latest online manuals; browse the Compatibility documents for system requirements; search the online Knowledge Base or join the worldwide Pro Tools community on the User Conference.

Training and Education Study on your own using courses available online or find out how you can learn in a classroom setting at a certified Pro Tools training center.

Products and Developers Learn about Avid products; download demo software or learn about our Development Partners and their plug-ins, applications, and hardware.

News and Events Get the latest news from Avid or sign up for a Pro Tools demo.

chapter 2

Installing Pro Tools on Mac

This chapter contains information for Mac systems only. If you are installing Pro Tools on a Windows computer, see Chapter 3, “Installing Pro Tools on Windows.”

 *Before installing this version of Pro Tools, refer to the Read Me information included on the Pro Tools Installer disc.*

Installation Overview

Installation of the Mbox on a Mac includes the following steps:

- 1 “Installing Pro Tools LE and Connecting Your Interface” on page 5.
- 2 “Launching Pro Tools LE” on page 7.
- 3 Configuring your system for improved performance (see Chapter 4, “Configuring Your Pro Tools System”).
- 4 Making audio connections to the Mbox (see Chapter 6, “Making Hardware Connections”).

 *The Pro Tools Installer disc includes additional software for your system. For more information, see “Additional Software on the Pro Tools Installer Disc” on page 8.*

Installing Pro Tools LE and Connecting Your Interface

Before connecting your Pro Tools LE interface to the computer, you need to install Pro Tools LE software.

 *Do not start this procedure with your Mbox connected to your computer.*

To install Pro Tools LE on Mac OS X:

- 1 Make sure you are logged in as an Administrator for the account where you want to install Pro Tools.

 *When the installation is complete, you will need to restart your computer.*

 *For details on Administrator privileges in Mac OS X, see your Apple OS X documentation.*

- 2 Insert the Pro Tools LE Installer disc in your DVD drive.

3 On the Installer disc, locate and double-click Install Pro Tools LE.mpkg.



Install Pro Tools LE.mpkg icon

4 Follow the on-screen instructions to proceed with installation.

5 Click Continue each time you are prompted.

6 At the Installation Type page, do one of the following:

- To install all Pro Tools application files and free plug-in suites (and associated content), leave the default Installation options selected and click Continue.

– or –

- Select (or deselect) a custom configuration of Installation options (see “Installation Options” on page 6) and click Continue.

7 Click Install.

8 If prompted, enter your Administrator password and click OK to authenticate the installation.

9 Follow the remaining on-screen instructions.

10 When installation is complete, click Restart.

11 After the computer has started, connect the small end of the included USB cable to the USB port on Mbox and connect the other end to any available USB port on your computer.

⚠ *If the USB LED on the front panel of the Mbox does not illuminate, try unplugging the USB cable from the Mbox USB port, and plugging it back in. If the USB LED still does not illuminate, shut down the computer, disconnect Mbox and start the computer. Once the computer has fully restarted, reconnect Mbox.*

⚠ *Mbox may not function properly if connected to a USB hub. If you need to use a hub for other USB peripherals, connect the hub to a separate USB port; Mbox must be connected to a dedicated port on the computer in order to function properly.*

Installation Options

Pro Tools LE Options

To install a subset of Pro Tools software and plug-ins (and associated content), click the reveal triangle for the Pro Tools LE 8.0.4 option in the installer, and deselect any of the following options that you do *not* want installed. (If an item is checked, it will be installed.)

Application Files (Required for Pro Tools) Installs the Pro Tools application and supporting library files needed to run Pro Tools. This option must be selected to install Pro Tools.

DigiRack Plug-Ins Installs free plug-ins including DigiRack plug-ins, free Bomb Factory plug-ins, Eleven Free, TL Utilities, and Digidesign D-Fi and Maxim plug-ins. For more information, see the *Audio Plug-Ins Guide*.

Pro Tools Creative Collection Options

Select any of the Pro Tools Creative Collection options you want installed. For more information, see the *Audio Plug-Ins Guide*.

Effect Plug-Ins Installs 6 free virtual instrument plug-ins from Avid's AIR group.

Virtual Instruments Installs 20 free effects plug-ins from Avid's AIR group.

Virtual Instrument Content Installs sample content for AIR virtual instruments.

⚠ *Virtual Instrument Content is very large and may take up to 20 minutes to install. During this time, the progress bar may not appear to move but your software is still installing. Do not terminate your installation.*

Additional Options

The Pro Tools installer provides the following additional options to install along with Pro Tools software and plug-ins.

Avid CoreAudio Drivers This option installs a multichannel sound driver that allows CoreAudio-compatible applications to record and play back through Avid audio interfaces.

Avid Video Engine This option lets you integrate Avid® video peripherals (such as the Avid Mojo® with your Pro Tools system). Do not install unless you will be using one of these products.

MIDI I/O Driver The MIDI I/O™ Driver is required if you are using the Avid MIDI I/O interface. Do not install unless you will be using a MIDI I/O.

Launching Pro Tools LE

When launching Pro Tools LE the first time, you are prompted to enter an authorization code to validate your software. (The code begins with the letters DIGI.)

To authorize Pro Tools LE software:

- 1 Make sure Mbox is connected to your computer.
- 2 Click the Pro Tools LE icon in the Dock (or double-click the application icon in the Pro Tools folder inside the Digidesign folder).
- 3 Enter the authorization code in the dialog (making sure to type it exactly as printed, and observing any spaces and capitalization), then click Validate. (Your authorization code is located on the inside front cover of this guide.)
- 4 Use the Quick Start dialog to do one of the following:
 - Create a new session from template.
 - Create a new blank session.
 - Open any other session on your system.



Quick Start dialog

 For more information on the Quick Start dialog and session templates, see the *Pro Tools Reference Guide (Help > Pro Tools Reference Guide)*.

Additional Software on the Pro Tools Installer Disc

The Pro Tools LE Installer disc provides additional software for your system, including audio drivers (for playing other audio applications through your Pro Tools hardware) and a Pro Tools demo session.

 Check your Pro Tools Installer disc for additional software and installers.

Third-Party Applications and Plug-Ins

Your Pro Tools package also includes free applications and plug-ins from Avid and selected Avid Third Party developers (content subject to change). Once you've completed your Pro Tools installation, you can install these separately.

Installers are located on your Pro Tools LE Installer disc in the Additional Files \3rd Party Content folder.

Avid CoreAudio Driver

The Avid CoreAudio Driver is a multi-client, multichannel sound driver that lets Core Audio-compatible applications record and play back through Pro Tools hardware.

The Avid CoreAudio Driver is installed by default when you install Pro Tools.

 For information on configuring the Avid CoreAudio Driver, see the CoreAudio Drivers Guide.

Standalone CoreAudio Driver

The Avid CoreAudio Driver can be installed as a standalone driver on Mac systems that do not have Pro Tools software installed.

 For information on installing and configuring the standalone version of the Avid CoreAudio Driver, see the CoreAudio Drivers Guide.

 If you uninstall Pro Tools, the Avid CoreAudio Driver is automatically uninstalled at that time.

Pro Tools Demo Session

The Pro Tools LE Installer disc includes a demo session that you can use to verify that your system is working.

The demo session for Pro Tool LE is named “Filtered Dream.”

 *Before installing the demo session to your audio drive, make sure the drive is configured as described in “Formatting an Audio Drive” on page 68.*

To install the demo session:

- 1 Insert the Pro Tools LE Installer disc into your DVD drive.
- 2 On the Pro Tools LE Installer disc, locate and open the Additional Files/Pro Tools Demo Sessions Installer folder.
- 3 Double-click Install demo session.pkg.
- 4 Follow the on-screen instructions.
- 5 When prompted, select your audio drive as the install location and click Next to begin the installation. When installation is complete, click Close.

 *The demo session can be opened by double-clicking the Filtered Dream.ptf file (located in the Filtered Dream Demo Session folder).*

Uninstalling Pro Tools

If you need to uninstall Pro Tools software from your computer, use the Uninstaller application.

To remove Pro Tools from your computer:

- 1 Make sure you are logged in as an Administrator for the account where Pro Tools is installed.

 *For details on Administrator privileges in Mac OS X, see your Apple OS X documentation.*

- 2 Go to Applications/Digidesign/Pro Tools/Pro Tools Utilities and double-click Uninstall Pro Tools
- 3 Click Continue to proceed with the uninstall.
- 4 Choose the type of uninstall you want to perform:

Safe Uninstall Leaves certain plug-ins and system files needed for compatibility with some Avid products. Use Safe Uninstall if you are using an Avid application or preparing to update to a CS (customer support) release.

Clean Uninstall Removes all Pro Tools files, including system files, Avid plug-ins, and MIDI patch names. Use Clean Uninstall whenever you are preparing to upgrade, or to troubleshoot from a clean system.

- 5 Click Uninstall.
- 6 Enter your Administrator password and click OK.
- 7 Click Finish to close the Installer window.

chapter 3

Installing Pro Tools on Windows

This chapter contains information for Windows systems only. If you are installing Pro Tools on a Mac computer, see Chapter 2, “Installing Pro Tools on Mac.”

A *Before installing this version of Pro Tools, refer to the Read Me information included on the Pro Tools LE Installer disc.*

Installation Overview

Installing the Mbox on a Windows computer includes the following steps:

- 1 “Installing Pro Tools LE and Connecting Your Interface” on page 11.
- 2 “Launching Pro Tools LE” on page 14
- 3 Configuring your system for improved performance (see Chapter 4, “Configuring Your Pro Tools System”).
- 4 Making audio and MIDI connections to the Mbox (see Chapter 6, “Making Hardware Connections” for details).

 *The Pro Tools Installer disc includes additional software for your system. For more information, see “Additional Software on the Pro Tools Installer Disc” on page 14.*

Installing Pro Tools LE and Connecting Your Interface

Before connecting your Pro Tools LE interface to the computer, you need to install Pro Tools LE software.

A *Do not start this procedure with your Mbox connected to your computer.*

To install Pro Tools LE:

1 Start Windows, logging in with Administrator privileges. For details on Administrator privileges, refer to your Windows documentation.

 *When the installation is complete, you will need to restart your computer.*

2 Insert the Pro Tools LE Installer disc in your DVD drive and do on of the following:

- If Windows AutoRun is enabled, a mini-browser appears. Select Install Pro Tools LE to begin your installation.

– or –

- If Windows AutoRun is disabled, locate and double-click Setup.exe. on the Installer disc.



Setup.exe icon

⚠ *In Windows 7 and Windows Vista, if the User Account Control dialog appears, click Allow.*

3 Follow the on-screen instructions to proceed with installation and click Next when prompted.

4 To install the complete compliment of Pro Tools software and plug-ins, leave Pro Tools selected.

5 At the Select Features page, do one of the following:

- To install all Pro Tools application files and free plug-in suites (and associated content), leave the default Installation options selected and click Continue.

– or –

- Select (or deselect) a custom configuration of Installation options (see “Installation Options” on page 13) and click Continue.

6 Click Next.

7 Click Install.

8 When prompted, connect the small end of the included USB cable to the USB port on Mbox. Connect the other end of the USB cable to any available USB port on your computer.

⚠ *Mbox may not function properly if connected to a USB hub. If you need to use a hub for other USB peripherals, connect the hub to a separate USB port; Mbox must be connected to a dedicated port on the computer in order to function properly*

9 Click OK.

⚠ *In Windows 7 and Windows Vista, a series of Windows Security dialogs may appear. Click “Install” on each one until they go away.*

⚠ *In Windows XP, a series of Software Installation dialogs about the driver not passing Windows Logo testing may appear. Click Continue Anyway on each one until they go away.*

If any other dialogs appear (such as the “Found New Hardware” dialog), leave them open and do not click on them. These dialogs will close on their own.

10 Wait for the installer to finish installing all software components, drivers, and PACE System files before proceeding to the next step.

11 When installation is complete, click Finish and restart your computer.

⚠ *If the USB LED on the front panel of the Mbox does not illuminate after restarting the computer, try unplugging the USB cable from the Mbox USB port, and plugging it back in. If the USB LED still does not illuminate, shut down the computer, disconnect Mbox and start the computer. Once the computer has fully restarted, reconnect Mbox.*

Installation Options

Pro Tools LE Options

To install a subset of Pro Tools software and plug-ins (and associated content), click the reveal triangle for the Pro Tools LE 8.0.4 option in the installer, and deselect any of the following options that you do *not* want installed. (If an item is checked, it will be installed.)

Application Files (Required for Pro Tools) Installs the Pro Tools application and supporting library files needed to run Pro Tools. This option must be selected to install Pro Tools.

DigiRack Plug-Ins Installs free plug-ins including DigiRack plug-ins, free Bomb Factory plug-ins, Eleven Free, TL Utilities, and Digidesign D-Fi and Maxim plug-ins. For more information, see the *Audio Plug-Ins Guide*.

Pro Tools Creative Collection Options

Select any of the Pro Tools Creative Collection options you want installed. For more information, see the *Audio Plug-Ins Guide*.

Effect Plug-Ins Installs 6 free virtual instrument plug-ins from Avid's AIR group.

Virtual Instruments Installs 20 free effects plug-ins from Avid's AIR group.

Virtual Instrument Content Installs sample content for AIR virtual instruments.

 *Virtual Instrument Content is very large and may take up to 20 minutes to install. During this time, the progress bar may not appear to move but your software is still installing. Do not terminate your installation.*

Additional Options

The Pro Tools installer provides the following additional options to install along with Pro Tools software and plug-ins.

Mac HFS+ Disk Support Option This option lets your Pro Tools system read, write, record, and play back using Mac-formatted HFS+ disks. HFS+ disks are commonly referred to as Mac OS Extended disks.

 *For information on using the Mac HFS+ Disk Support option, see the *HFS+ Disk Support Option Guide*.*

Avid Video Engine This option lets you integrate Avid® video peripherals (such as the Avid Mojo® with your Pro Tools system). Do not install unless you will be using one of these products.

Command|8 Controller and Driver This option installs the personality file and device driver for the Avid Command|8 Control Surface. Do not install unless you will be using Command|8.

Installing QuickTime

QuickTime is required for Pro Tools if you plan to include movie files, or import MP3 or MP4 (AAC) files in your sessions. QuickTime for Windows is available as a free download from the Apple website (www.apple.com).

 *For information on which version of QuickTime is compatible with your version of Pro Tools, visit www.avid.com/compatibility.*

To install QuickTime:

- 1 Visit www.apple.com and go to the QuickTime page.
- 2 Download the QuickTime installer application to your computer.
- 3 Double-click the QuickTime installer application and follow the on-screen installation instructions.
- 4 Restart your computer.

Launching Pro Tools LE

When launching Pro Tools LE the first time, you are prompted to enter an authorization code to validate your software. (The code begins with the letters DIGI.).

To authorize Pro Tools LE software:

- 1 Make sure Mbox is connected to your computer.
- 2 Double-click the Pro Tools LE shortcut on your desktop (or the application icon in the Pro Tools folder inside the Digidesign folder).
- 3 Enter the authorization code in the dialog (making sure to type it exactly as printed, and observing any spaces and capitalization), then click Validate. (Your authorization code is located on the back of your Pro Tools DVD wallet).
- 4 Use the Quick Start dialog to do one of the following:
 - Create a new session from template.
 - Create a new blank session.
 - Open any other session on your system.



Quick Start dialog

 For more information on the Quick Start dialog and session templates, see the *Pro Tools Reference Guide (Help > Pro Tools Reference Guide)*.

Additional Software on the Pro Tools Installer Disc

The Pro Tools LE Installer disc provides additional software for your system, including audio drivers (for playing other audio applications through your Pro Tools hardware) and a Pro Tools demo session.

 Check your Pro Tools Installer disc for additional software and installers.

Third-Party Applications and Plug-Ins

Your Pro Tools package also includes free applications and plug-ins from Avid and selected Avid Third Party developers (content subject to change). Once you've completed your Pro Tools installation, you can install these separately.

Installers are located on your Pro Tools LE Installer disc in the Additional Files\3rd Party Content folder.

Avid Audio Drivers

The Avid Audio Drivers are multi-client, multi-channel sound drivers that allow Pro Tools and third-party audio programs that support the ASIO Driver or WaveDriver MME/DirectX (Multimedia Extension) standards to record and play back through qualified Pro Tools audio interfaces.

 For information on configuring settings for your audio interface for use with Pro Tools or other audio applications, see Appendix A, “Using the Driver Control Panel.”

 For additional information on the Avid Audio Drivers, see the Windows Audio Drivers Guide.

Pro Tools Demo Session

The Pro Tools LE Installer disc includes a demo session that you can use to verify that your system is working.

The demo session for Pro Tool LE is named “Filtered Dream.”

 Before installing the demo session to your audio drive, make sure the drive is configured as described in “Formatting an Audio Drive” on page 68.

To install the demo session:

- 1 Insert the Pro Tools LE Installer disc into your DVD drive.
- 2 On the Pro Tools LE Installer disc, locate and open the Additional Files\Pro Tools Demo Sessions Installer folder.

- 3 Double-click LE Demo Session Setup.exe.
- 4 Follow the on-screen instructions.
- 5 When prompted, select your audio drive as the install location and click Next to begin the install.
- 6 When installation is complete, click Finish.

 The demo session can be opened by double-clicking the Filtered Dream.ptf file (located in the Filtered Dream Demo Session folder).

Uninstalling Pro Tools

Use the Uninstall Pro Tools application to uninstall Pro Tools software from your computer.

To uninstall Pro Tools from your computer:

- 1 Start Windows, logging in with Administrator privileges. For details on Administrator privileges, refer to your Windows documentation.
- 2 Go to C:\Program Files\Digidesign\Pro Tools\Pro Tools Utilities and double-click Uninstall Pro Tools.exe.
- 3 Click Next.
- 4 Click Uninstall to proceed with the uninstallation.

chapter 4

Configuring Your Pro Tools System

After you have connected your system and installed Pro Tools software, you are ready to start up and configure your Pro Tools system.

Starting Up or Shutting Down Your System

To ensure that the components of your Pro Tools system communicate properly with each other, you need to start them in a particular order.

Start up your Pro Tools system in this order:

- 1 Make sure all your equipment (including your computer) is off.
- 2 Lower the volume of all output devices in your system (especially the main outputs to your speakers!).
- 3 Turn on any external hard drives. Wait approximately ten seconds for them to spin up to speed.
- 4 Turn on any control surfaces (such as Command|8).
- 5 Turn on any MIDI interfaces, MIDI devices, or synchronization peripherals.

- 6 With the volume of all output devices lowered, turn on your Pro Tools audio interfaces. Wait at least fifteen seconds for the audio interface to initialize and the status LEDs to stop flashing.

- 7 Turn on your computer.

- 8 Launch Pro Tools or any third-party audio or MIDI applications.

- 9 Bring the output levels up to a comfortable listening level.

Shut down your Pro Tools system in this order:

- 1 Quit Pro Tools and any other running applications.



To quit Pro Tools, choose Pro Tools > Quit (Mac) or File > Exit (Windows).

- 2 Turn off or lower the volume of all output devices in your system.

- 3 Turn off your computer.

- 4 Turn off any MIDI interfaces, MIDI devices, or synchronization peripherals.

- 5 Turn off any control surfaces.

- 6 Turn off any external hard drives.

Configuring Pro Tools LE

Pro Tools System Settings

In the Playback Engine dialog, Pro Tools LE lets you adjust the performance of your system by changing *system settings* that affect its capacity for processing, playback, and recording.

In most cases, the default settings for your system provide optimum performance, but you may want to adjust them to accommodate large or processing-intensive Pro Tools sessions.

Hardware Buffer Size

The Hardware Buffer Size (H/W Buffer Size) controls the size of the buffer used to handle host processing tasks such as Real-Time AudioSuite™ (RTAS®) plug-ins.

- Lower Hardware Buffer Size settings are useful for improving latency issues in certain recording situations or for improving certain system performance problems. On Pro Tools LE systems, lower settings reduce all input-to-output monitoring latency on any record-armed tracks or Auxiliary Input tracks with live inputs.
- Higher Hardware Buffer Size settings are useful for sessions that are using more RTAS plug-ins for playback. These settings allow for more audio processing. They can also be useful to reduce errors on some machines that require a higher buffer size.

⚠ *In addition to causing slower screen response and monitoring latency, higher Hardware Buffer Size settings can increase the latency caused by RTAS plug-ins, and affect the accuracy of plug-in automation, mute data, and MIDI track timing.*

To change the Hardware Buffer Size:

- 1 Launch Pro Tools
- 2 Choose Setup > Playback Engine.
- 3 From the H/W Buffer Size pop-up menu, select the audio buffer size, in samples.

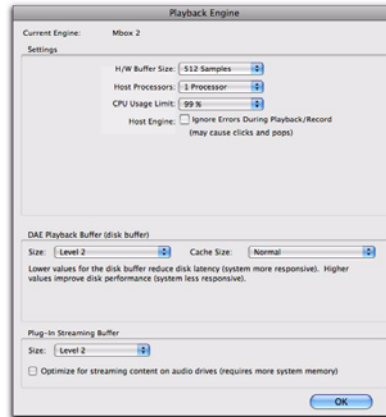

Playback Engine dialog for Pro Tools LE, with Structure Free plug-in installed. (Mbox 2 shown)

- 4 Click OK.

Host Processors

The Host Processors setting lets you manage multi-processor support for RTAS (Real-Time AudioSuite) plug-in processing.

Used in combination with the CPU Usage Limit setting, the Host Processors setting lets you control the way RTAS and other host-based processing tasks are carried out by the system.

For example:

- For sessions with large numbers of RTAS plug-ins, you can allocate 2 or more processors to RTAS processing and set a high CPU Usage Limit.
- For sessions with few RTAS plug-ins, you can allocate fewer Host Processors to RTAS and set a low CPU Usage Limit settings to leave more host processing resources available for automation accuracy, screen response, and video.
- Depending on the importance of video and overall screen response, and on the density of automation being employed, try different combinations of Host Processors and CPU Usage Limit settings to achieve the best results. For example, to improve screen response in a medium-sized session using a moderate number of RTAS plug-ins, try reducing the number of RTAS plug-ins, but keep the CPU Usage Limit set to the maximum (up to 99% on a single processor system).

To set the number of RTAS Processors:

- 1 Choose Setup > Playback Engine.
- 2 From the Host Processing pop-up menu, select the number of available processors you want to allocate. The number of processors available varies depending on your computer:
 - Select 1 Processor to limit processing to one CPU in the system.
 - Choose 2 Processors to enable load balancing across two available processors.
 - On systems running four or more processors, choose the number of processors for processing.
- 3 Click OK.

System Usage Window and Processing

The System Usage window (Windows > System Usage) displays the combined amount of processing occurring on all enabled processors with a single indicator, regardless of how many processors are available in the system. If the System Usage Window shows that you are at the limit of available resources, increase the number of processors and adjust the CPU Usage Limit setting.

CPU Usage Limit

The CPU Usage Limit setting controls the percentage of CPU resources allocated to Pro Tools host processing tasks. Used in combination with the Host Processors setting, the CPU Usage Limit setting lets you control the way Pro Tools tasks are carried out by the system.

- Lower CPU Usage Limit settings limit the effect of Pro Tools processing on other CPU-intensive tasks, such as screen redraws, and are useful when you are experiencing slow system response, or when running other applications at the same time as Pro Tools.
- Higher CPU Usage Limit settings allocate more processing power to Pro Tools, and are useful for playing back large sessions or using more RTAS plug-ins.

The maximum available CPU Usage Limit depends on the number of processors in your computer and on the number of processors you specify for RTAS processing. This value can range from 85% for single-processor computers, and 99% for multiprocessor computers (which dedicate one entire processor to Pro Tools).

On multiprocessor computers, the maximum CPU Usage Limit is reduced when you use all your processors (as selected in the Processing pop-up menu). For example, on dual-processors, the limit is 90%. On four-processor computers, the limit is 95%.

 *Increasing the CPU Usage Limit may slow down screen responses on slower computers.*

To change the CPU Usage Limit:

- 1 Choose Setup > Playback Engine.
- 2 From the CPU Usage Limit pop-up menu, select the percentage of CPU processing you want to allocate to Pro Tools.
- 3 Click OK.

Host Engine (Error Suppression)

The Host Engine option determines RTAS error reporting during playback and recording. This is especially useful when working with instrument plug-ins.

You should only enable error suppression if you are experiencing frequent RTAS errors that are interrupting your creative workflow. When error suppression is enabled, you can experience a degradation of audio quality. However, this may be acceptable in order to avoid interrupting playback and recording when working with instrument plug-ins. Be sure to disable error suppression when you need to ensure the highest possible audio quality, such as for a final mix.

To enable error suppression:

- 1 Choose Setup > Playback Engine.
- 2 Select Host Engine: Ignore Errors During Playback/Record.
- 3 On Mac, you can also select Minimize Additional I/O Latency.
- 4 Click OK.

Error Suppression Options

Ignore Errors During Playback/Record When the Ignore Errors During Playback/Record option is enabled, Pro Tools continues to play and record even if the host processing requirements exceed the selected CPU Usage Limit. This can result in pops and clicks in the audio, but does not stop the transport.

Minimize Additional I/O Latency (Mac Only)

When enabled, any additional latency due to suppressing errors during playback and record is minimized to 128 samples. Suppressing RTAS errors requires at least 128 samples of additional buffering on some systems. If this option is disabled, the buffer is half the H/W Buffer Size, or at least 128 samples (whichever is greater). If you are on an older, slower computer, you may want to disable this option to avoid adverse performance.

This option is only available on Mac if the Ignore Errors During Playback/Record option is enabled.

DAE Playback Buffer Size

The DAE Playback Buffer Size setting determines the amount of memory DAE allocates for disk buffers. In addition to levels, the DAE Playback Buffer Size shows values in milliseconds, which indicate the amount of audio buffered when the system reads from disk.

The optimum DAE Playback Buffer Size for most disk operations is 1500 msec; Level 2 (Default).

- DAE Playback Buffer Size settings lower than 1500 msec; Level 2 (Default) may improve playback and recording initiation speed, as well as preview in context in DigiBase browsers. However, a lower setting may make it difficult to play or record tracks reliably with sessions containing a large number of tracks or a high density of edits, or with systems that have slower or heavily-fragmented hard drives.

- DAE Playback Buffer Size settings higher than 1500 msec; Level 2 (Default) allow higher track count, higher density of edits in a session, or the use of slower hard drives. However, a higher setting may increase the time lag when starting playback or recording, starting preview in context from DigiBase browsers, or cause a longer audible time lag while editing during playback.



Using a larger DAE Playback Buffer Size leaves less system memory for other tasks. The default setting of 1500 msec (Level 2) is recommended unless you are encountering -9073 ("Disk too slow or fragmented") errors.

To change the DAE Playback Buffer Size:

- 1 Choose Setup > Playback Engine.
- 2 From the DAE Playback Buffer pop-up menu, select a buffer size. Memory requirements for each setting are shown at the bottom of the Playback Engine dialog.
- 3 Click OK.

If Pro Tools needs more system memory for the DAE Playback Buffer, it will prompt you to restart your computer.

Cache Size

The Cache Size setting determines the amount of memory DAE allocates to pre-buffer audio for playback and looping when using Elastic Audio.

Minimum Reduces the amount of system memory used for disk operations and frees up memory for other system tasks. However, performance when using Elastic Audio features may decrease.

Normal Is the optimum Cache Size for most sessions.

Large Improves performance when using Elastic Audio features, but it also decreases the amount of memory available for other system tasks, such as RTAS processing.



Using a larger Cache Size leaves less system memory for other tasks. The default setting of Normal is recommended unless you are encountering -9500 ("Cache too small") errors.

To change the Cache Size:

- 1 Choose Setup > Playback Engine.
- 2 From the Cache Size pop-up menu, select a disk cache size.
- 3 Click OK.

Plug-In Streaming Buffer Size

(Structure Plug-In Only)

This setting appears in the Playback Engine dialog only if Structure, Structure LE, or Structure Free is installed on your system. The Plug-In Streaming Buffer Size determines the amount of memory DAE allocates for streaming playback from disk with the Structure plug-in. This setting only affects playback if disk streaming is activated in Structure's plug-in controls (see the *AIR Virtual Instruments Guide* for more information).

The optimum Plug-In Streaming Buffer Size for most sessions is 250 ms (Level 2).

- Plug-In Streaming Buffer Size settings lower than 250 ms (Level 2) reduce the amount of system memory used for sample playback and frees up memory for other system tasks. However, audio quality of sample playback may decrease.
- Plug-In Streaming Buffer Size settings higher than 250 ms (Level 2) improve the audio quality of sample playback, but they also decrease the amount of memory available for other system tasks, such as RTAS processing.



Using a larger Plug-In Streaming Buffer Size leaves less system memory for other tasks. The default setting of 250 ms (Level 2) is recommended unless you are experiencing problems with the audio quality of sample playback.

To change the Plug-In Streaming Buffer Size:

- 1 Choose Setup > Playback Engine.
- 2 From the Plug-In Streaming Buffer Size pop-up menu, select a buffer size.
- 3 Click OK.

Optimizing the Plug-In Streaming Buffer Size

(Structure Plug-In Only)

This option appears in the Playback Engine dialog only if one of the Structure sampler instrument plug-in is installed on your system. This option is useful when you are playing samples from the same drive that contains audio for the current session. When this option is selected, Pro Tools automatically optimizes the size of the Plug-In Streaming Buffer to facilitate disk access from both Pro Tools and Structure. The Plug-In Streaming Buffer Size pop-up menu is unavailable when this option is selected.

To set Pro Tools to optimize the Plug-In Streaming Buffer Size:

- 1 Choose Setup > Playback Engine.
- 2 Select the Optimize for Streaming Content option.
- 3 Click OK.

Configuring the Pro Tools Hardware Settings

In the Hardware Setup dialog, Pro Tools lets you set the default sample rate and clock source for your system, as well as a range of controls specific to each type of audio interface.

Default Sample Rate

The Sample Rate setting appears as the default sample rate when you create a new session. (This setting is available in the Hardware Setup dialog only when no session is open.)



You can change the sample rate when creating a new Pro Tools session by selecting a different sample rate in the New Session dialog. (Refer to the Pro Tools Reference Guide for details.)

To change the default Sample Rate:

- 1 Choose Setup > Hardware.

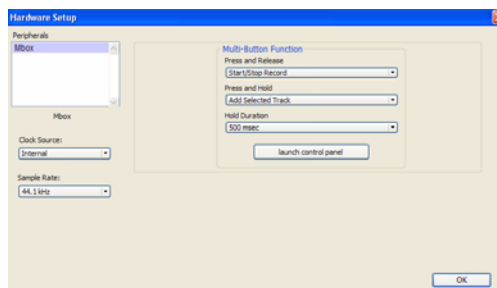

Hardware Setup dialog

- 2 Select the sample rate from the Sample Rate pop-up menu.
- 3 Click OK.

Clock Source

The Pro Tools Hardware Setup dialog lets you select the Clock Source for the system.

Internal If you are recording an analog signal directly into Pro Tools, you will usually use the Pro Tools Internal clock source.

S/PDIF Use this setting if you are recording through the Mbox S/PDIF input from an external digital device. This setting will synchronize Pro Tools to that digital device.

To select the Clock Source:

- 1 Choose Setup > Hardware.
- 2 Choose the clock source from the Clock Source pop-up menu.
- 3 Click OK.

⚠ *Your digital input device must be connected and powered on for Pro Tools to synchronize to it. If your input device is not powered on, leave the Clock Source set to Internal.*

Configuring I/O Setup

Using the I/O Setup dialog, you can label Pro Tools LE input, output, insert, and bus *signal paths*. The I/O Setup dialog provides a graphical representation of the inputs, outputs, and signal routing of the Mbox.

Pro Tools LE has default I/O Setup settings that will get you started. Use the I/O Setup dialog only if you want to rename the default I/O paths.

To rename I/O paths in I/O Setup:

- 1 Choose Setup > I/O.

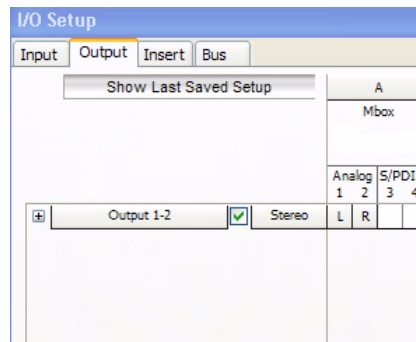

I/O Setup dialog for Mbox

- 2 Click the Input, Output, Insert, or Bus tab to display the corresponding connections.
- 3 To change the name of a path or subpath, double-click directly on the Path Name, type a new name for the path, and press Enter.
- 4 Click OK.

 See the Pro Tools Reference Guide (Help > Pro Tools Reference Guide) for more information on renaming I/O paths.

Configuring MIDI Setup

If you plan to use any MIDI devices with Pro Tools, do one of the following:

- On Mac, configure your MIDI setup with Audio MIDI Setup. See Appendix C, “Configuring AMS (Mac OS X Only)” for details.
– or –
- On Windows, configure your MIDI setup with MIDI Studio Setup. See Appendix D, “Configuring MIDI Studio Setup (Windows Only)” for details.

Backing Up your System Configuration

After configuring your system and Pro Tools, you should save an image of your system drive using a backup utility such as Bombich Carbon Copy Cloner or Time Machine (Mac) or Acronis True Image or Norton Ghost (Windows). By doing this, you can quickly restore your system configuration and settings if you encounter any problems.

Optimizing a Mac System for Pro Tools

To ensure optimum performance with Pro Tools, configure your computer before using Pro Tools hardware and software.

Before configuring your computer, make sure you are logged in as an Administrator for the account where you want to install Pro Tools. For details on Administrator privileges in Mac OS X, see your Apple OS X documentation.

 *Do not use the Mac OS X automatic Software Update feature, as it may upgrade your system to a version of Mac OS that has not yet been qualified for Pro Tools. For details on qualified versions of Mac OS, visit www.avid.com/compatibility.*

Turning Off Software Update

To turn off the Software Update feature:

- 1 Choose System Preferences from the Apple menu and click Software Update.
- 2 Click the Scheduled Check tab.
- 3 Deselect “Check for Updates.”

Turning Off Energy Saver

To turn off the Energy Saver feature:

- 1 Choose System Preferences from the Apple menu and click Energy Saver.
- 2 Do the following:
 - Set the computer sleep setting to Never.
 - Set the display sleep setting to Never.
 - Deselect “Put the hard disk(s) to sleep when possible.”

Disable or Reassign Mac Keyboard Shortcuts Used by Pro Tools

To have the full complement of Pro Tools keyboard shortcuts, you need to disable or reassign any conflicting Mac OS X Keyboard Shortcuts in the Apple System Preferences, including the following:

- “Show Help menu”
- Under “Keyboard Navigation”
 - “Move focus to the window drawer”
- Under “Dock, Exposé, and Dashboard”
 - “Automatically hide and show the Dock”
 - “All windows”
 - “Application windows”
 - “Desktop”
 - “Dashboard”
 - “Spaces”
- Under “Spotlight”
 - “Show Spotlight search field”
 - “Show Spotlight window”

For a complete list of Pro Tools keyboard shortcuts, see the Keyboard Shortcuts Guide (Help > Keyboard Shortcuts).

To disable or reassign Mac OS X keyboard shortcuts:

- 1 Choose System Preferences from the Apple menu and click Keyboard.
- 2 Click the Keyboard Shortcuts tab.
- 3 Do one of the following:
 - Deselect the Mac OS X options that conflict with Pro Tools keyboard shortcuts.
 - or –
 - Assign different, non-conflicting keyboard shortcuts to the corresponding Mac OS X options.

Reassign Spaces Keyboard Shortcuts

If you want to use Spaces, you should reassign the Spaces keyboard shortcuts to avoid conflicts with important Pro Tools keyboard shortcuts. You can reassign Spaces keyboard shortcuts to use a combination of modifier keys (Command+Option+Control+Shift) in addition to the default Spaces keyboard shortcut assignments to avoid these conflicts.

To reassign Spaces keyboard shortcuts to use modifier key combinations that do not conflict with Pro Tools keyboard shortcuts:

- 1 Choose System Preferences from the Apple menu and click Exposé & Spaces.
- 2 Click the Spaces tab.
- 3 Ensure that Enable Spaces is selected.
- 4 Press and hold Command+Option+Control+Shift and select “Control+Option+Shift+Command+F8” from the “To activate Spaces” pop-up menu.
- 5 Press and hold Command+Option+Control+Shift and select “Control+Option+Shift+Command+Arrow Keys” from the “To switch between spaces” pop-up menu.

- 6 Press and hold Command+Option+Control+Shift and select “Control+Option+Shift+Command+Number Keys” from the “To switch directly to a space” pop-up menu.

Disabling Spotlight Indexing

The Mac OS X Spotlight feature automatically indexes files and folders on local hard drives in the background. In most cases, this is not a concern for normal Pro Tools operation. However, if Spotlight starts indexing drives while recording in a Pro Tools session with high track counts for an extended period of time, it can adversely affect Pro Tools system performance. You may want to disable Spotlight indexing for all local drives before using Pro Tools for big recording projects.

Disabling Spotlight indexing also disables the Find function in Mac OS X.

To disable Spotlight indexing:

- 1 Choose System Preferences from the Apple menu and click Spotlight.
- 2 In the Spotlight window, click the Privacy tab.
- 3 To prevent indexing of a drive, drag its icon from the desktop into the list.

Enabling Journaling for Audio Drives

To yield higher performance from audio drives, enable journaling.

To enable journaling:

- 1 Launch the Disk Utility application, located in Macintosh HD/Applications/Utilities.
- 2 Select the volume in the left column of the Disk Utility window.
- 3 Select Enable Journaling in the toolbar.

Optimizing a Windows System for Pro Tools

To ensure optimum performance with Pro Tools LE, configure your computer before using Pro Tools hardware and software.

 For Mac System Optimization, see “Optimizing a Mac System for Pro Tools” on page 25.

Before configuring your computer, make sure you are logged in as an Administrator for the account where you want to install Pro Tools. For details on Administrator privileges, see your Windows documentation.

Required Optimizations

To ensure optimum performance with Pro Tools, configure the following settings before using Pro Tools hardware and software.

 When you are finished changing Windows system settings, restart your computer.

Enabling DMA

Enabling your computer's DMA (Direct Memory Access) frees up CPU bandwidth so your computer can do other Pro Tools tasks.

In most cases the DMA option will already be set correctly, as Windows detects and activates DMA mode by default.

To enable DMA for any IDE hard drives (Windows 7, Windows Vista, Windows XP):

- 1 Choose Start.
- 2 Right-click Computer (Windows 7, Windows Vista) or My Computer (Windows XP) and choose Manage.
- 3 In the left pane of Computer Management under System Tools, click on Device Manager.
- 4 In the right pane, click the triangle (Windows 7) or the plus (+) sign (Windows Vista, Windows XP) next to IDE ATA/ATAPI Controllers.
- 5 Double-click on an IDE Channel.
- 6 Click the Advanced Settings tab.
- 7 Under Device Properties, check the box Enable DMA (Windows 7, Windows Vista) or under each listed Device, set the Transfer Mode to DMA if available (Windows XP).
- 8 Click OK.
- 9 Repeat for each IDE Channel.

Configuring Windows Power Management Settings

Pro Tools requires maximum CPU performance for optimal RTAS processing and disk streaming. For best performance, use the following recommended Windows Power Management settings.

To configure Windows Power Management Settings (Windows 7, Windows Vista):

- 1 Choose Start > Control Panel.
- 2 Click Hardware and Sound > Power Options.
- 3 In the Power Options control panel, click High Performance.
- 4 Click Change plan settings.
- 5 Click Change advanced power settings to change additional settings.
- 6 Click Hard disk > Turn off hard disk after = Never. You can make optional changes such as disabling sleep and disabling shutting down the monitor.
- 7 Click OK or click Save changes to save the changes.
- 8 Close the window.

To configure Windows Power Management Settings (Windows XP):

- 1 Choose Start > Control Panel.
- 2 Double-click Power Options.
- 3 Click the Power Schemes tab.
- 4 From the Power Schemes pop-up menu, select Always On.
- 5 Verify that the following settings are set to Never:
 - Turn off hard disks
 - System standby
 - System hibernates
- 6 Click OK.

Disabling User Account Control (Windows 7, Windows Vista)

Some third-party applications that interface with Pro Tools may require UAC to be disabled for proper operation.

To disable User Account Control (UAC):

- 1 Choose Start > Control Panel.
- 2 Click User Accounts and Family Safety.
- 3 In the User Accounts and Family Safety control panel, click User Accounts.
- 4 Click Change User Account Control settings (Windows 7) or Turn User Account Control on or off (Windows Vista).
- 5 Move the User Account Control slider to Never Notify (Windows 7), or deselect the Use User Account Control (UAC) to help protect your computer option (Windows Vista).
- 6 Click OK.
- 7 Restart your computer.

Recommended Optimizations

Pro Tools can also be affected by other software and hardware drivers installed on your computer. For best possible performance, it is recommended (but not required) that you do the following:

- Avoid running any unneeded programs at the same time as Pro Tools.
- Turn off any software utilities that run in the background, such as Windows Messenger, calendars, and disk maintenance programs.
- Turn off any non-essential USB devices while running Pro Tools.
- If your video display card supports it, enable Bus Mastering in the manufacturer's Control Panel. See the manufacturer's instructions for details.

Optional Optimizations

The following system optimizations may help Pro Tools perform better on some systems. It is recommended that you only try these optimizations if necessary, as they may disable or adversely affect the functionality of other programs on your system.

Disabling Network Cards

If applicable, disable any networking cards (other than a FireWire card that you might use to connect an external drive to your system).

To disable a network card (Windows 7, Windows Vista):

- 1 Choose Start > Computer.
- 2 Click System Properties.
- 3 In the left-hand pane under Control Panel Home, click on Device Manager.
- 4 In the Device Manager window, double-click Network adapters.
- 5 Right-click on the network adapter and select Disable.
- 6 Repeat as necessary for additional network adapters.
- 7 Close the Device Manager window.

To disable a network card (Windows XP):

- 1 Right-click My Computer and choose Manage.
- 2 Under System Tools, select Device Manager.
- 3 In the right-hand pane, click "+" to reveal Network adapters.
- 4 In the Device Manager window, double-click Network adapters.
- 5 Right-click on the network adapter and select Disable.
- 6 Repeat as necessary for additional network adapters.
- 7 Close the Computer Management window.

Adjusting Processor Scheduling

To adjust Processor Scheduling performance (Windows 7, Windows Vista, Windows XP):

- 1 Right-click Computer (Windows 7, Windows Vista) or My Computer (Windows XP) and choose Properties.
- 2 Click the Advanced system settings link in the left pane (Windows 7, Windows Vista) or the Advanced tab (Windows XP).
- 3 Under the Performance section, click the Settings button.
- 4 In the Performance Options window, click the Advanced tab.
- 5 Under the Processor Scheduling section, select the Background Services option.
- 6 Click OK to close the Performance Options window.
- 7 Click OK to close the System Properties window.
- 8 Restart the computer for the changes to take effect.

Disabling System Startup Items

The fewer items in use by your computer, the more resources are available for Pro Tools. Some startup applications may be consuming unnecessary CPU resources, and can be turned off.

If you disable any of the following startup items, do so carefully:

- Portable media serial number (required for some applications that utilize a copy protection key)
- The Plug and Play service
- Event log
- Cryptographic services

To Disable System Startup Items: (Windows 7, Windows Vista, Windows XP):

- 1 From the Start menu, type "msconfig" in Start Search (Windows 7, Windows Vista) or in Run (Windows XP) and click OK to open the System Configuration Utility.
- 2 Under the General tab, choose Selective Startup.
- 3 Deselect Load Startup Items and click OK.
- 4 Click Restart to restart the computer.
- 5 After restarting, the computer displays a System Configuration message. Check to see if Pro Tools performance has increased before you deselect the Don't show this message again option. If performance has not changed, run "msconfig" and return your computer Startup Selection back to Normal Startup - load all device drives and services. Alternatively, try disabling Startup items and non-essential processes individually.

chapter 5

Mbox Hardware Overview

Mbox Front Panel Features

Figure 1 identifies controls, indicators, and input and output ports on the front panel on the Mbox.

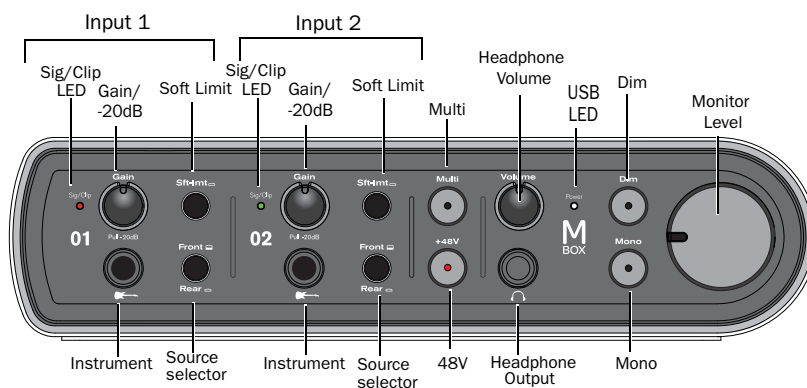

Figure 1. Mbox front panel

The Mbox front panel provides the following:

Signal/Clip LEDs

These LEDs illuminate green in the presence of audio signal, and illuminate red if the signal reaching Mbox has clipped.

Gain Controls/-20dB Pad

These knobs adjust the input gain levels of the Mic/Line inputs. Turn the knob clockwise to increase gain, and counter-clockwise to decrease gain.

If your input signal is too hot even with the Gain knob at a low setting, pull the Gain knob out to engage a “pad” that attenuates the signal by 20dB.

Instrument Inputs

These 1/4-inch TS inputs are for connecting an electric guitar, bass, or other instrument-level signal. The level for these inputs is controlled by the Gain Controls.

Soft-Limit Buttons

These buttons activate the Soft-Limit function, applying a smooth, overdriven tape-type limiting to strong input signals.

Front/Rear Source Selectors

These buttons select either the front panel Instrument Inputs (TS) or rear panel Mic/Line Inputs (XLR/TRS combo) for each channel. When the button is set to the Out position, the front panel Instrument Inputs will be active. When the button is set to the In position, the rear panel Mic/Line Inputs will be active.

Multi Button

The Multi Button can be assigned to execute several functions in Pro Tools, including Add Track, Start/Stop Record, Tap Tempo, Toggle Marker Locations, and Save Session.

48V Switch and LED

Phantom power is activated by the switch labeled 48V on the front panel of Mbox. The LED, when lit, indicates that 48V phantom power is active on the XLR Mic inputs. These inputs provide phantom power for microphones that require it to operate.

About Phantom Power

Dynamic microphones (such as a Shure SM57) do not require phantom power to operate, but are not harmed by it. Most *condenser* microphones (like an M-Audio Solaris) *do* require phantom power to operate.

⚠ *Although phantom power can be used safely with most microphones, it is possible to damage some ribbon microphones with it. Always turn off phantom power and wait at least ten seconds before connecting or disconnecting a ribbon microphone.*

⚠ *When using phantom power, the Mbox maximum current per microphone is 4 mA.*

If you are not sure about the phantom power requirements for your microphone, consult your microphone's documentation or contact the manufacturer.

Headphone Volume

The Headphone Volume knob adjusts the output level of the Headphone port, which outputs the signal that is routed to Outputs 1–2 in Pro Tools LE, and mirrors the Line Outputs.

Front Panel Headphone Output

Use the Headphone Output to connect stereo headphones with a 1/4-inch stereo connector.

USB LED

The USB LED indicates that the Mbox is receiving power from its USB connection. Once the USB light is on, audio can pass in or out of the system.

The USB LED is a power LED, which will also indicate when the unit is powered in stand-alone mode. In this mode you can connect a USB cable but that cable will be connected to a wall outlet instead of a computer (similar to an iPod or iPhone).

Dim Button and LED

The Dim Button reduces by 30 dB the output volume from both the Line Outputs and the Headphone Output. When engaged, the Dim LED lights.

Guitar Tuner Function

When the Dim Button and the Mono Button are pushed at the same time, the Guitar Tuner function is activated. The Dim and Mono LEDs will flash between off and on to indicate tuner mode is active. When a string is played on a guitar plugged into an Instrument Input, the Input 1 Signal/Clip LED will be illuminated red if tuning is too low, off when tuning is too high, and green when tuning is correct. The Input 2 Signal/Clip LED will be illuminated red if tuning is too high, off when tuning is too low, and green when tuning is correct. The Tuner interface will be displayed in the Software Control panel if the Software Control Panel is open.

Mono Button

The Mono Button sums the control room outputs to a mono signal (delivering that identical signal to both speakers) via the Driver Control Panel or the Mbox. When engaged, the Mono LED lights.

Checking Phase Relationships

The Mono switch can also be used for a quick check of the phase relationship between Source 1 and Source 2 inputs.

Monitor Level

The Monitor Level knob adjusts the output level of the Monitor Output ports.

Mbox Back Panel Features

Figure 2 identifies each port on the back panel of the Mbox.

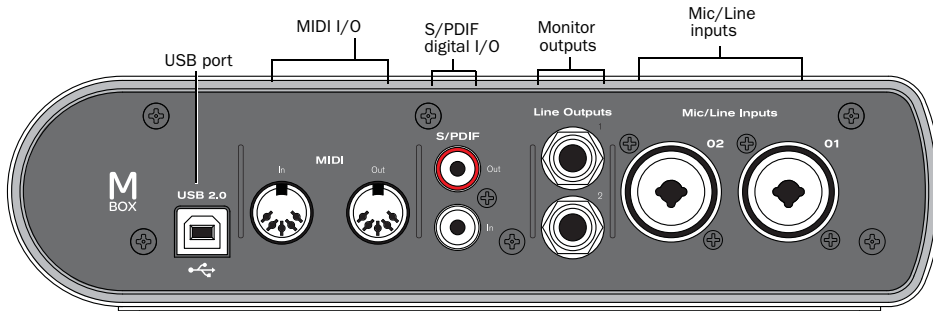

Figure 2. Mbox back panel

The Mbox back panel provides the following:

USB Port

This standard USB connector is used to connect a USB 2.0 port on your computer to the Mbox. One standard USB cable is included with your system. (It is also used to power the unit in stand-alone mode.)

MIDI I/O

The MIDI In and MIDI Out ports are standard 5-pin MIDI ports, each providing 16 channels of MIDI input and output.

S/PDIF Digital I/O

The S/PDIF in and out ports are unbalanced two-conductor phono (RCA) connectors that utilize a full 24-bit, two-channel digital data stream.

The Sony/Philips Digital Interface Format (S/PDIF) is used in many professional and consumer CD recorders and DAT recorders. To avoid RF interference, use 75-ohm coaxial cable for S/PDIF transfers and keep the cable length to a maximum of 10 meters.

In use, the S/PDIF input channels are available in addition to the two channels of analog input. This lets Mbox be used as a 4-in/4-out digital audio interface for Pro Tools LE.

Line Outputs

These outputs support balanced TRS, or unbalanced TS, 1/4-inch connections. To monitor your mix, these outputs can be connected to a mixing board, directly to a monitoring system such as a stereo power amp, or another stereo destination.

Mic/Line Inputs

Each analog source input channel provides combination XLR/TRS on the rear panel. These balanced/unbalanced analog audio inputs support the following input levels:

- Mic (microphone) for XLR inputs
- Line (TRS) for line level signals on TRS or TS inputs

On the front panel, the input signal is adjusted by the Gain control for each channel and the source (rear panel Mic/Line, or front panel Instrument) is chosen using the Source selectors.

Mic/Line Input 2 is at the far left (when looking at the back panel), and Mic/Line Input 1 is to its right. The back panel inputs for Mic/Line Input 1 and Mic/Line Input 2 are located such that they are directly in line with their associated input controls on the front panel. This lets you locate input jacks more easily when viewing from the front of the unit.

chapter 6

Making Hardware Connections

To hear audio recorded into a Pro Tools session, you will need to connect headphones or an external sound system (such as powered monitors or a home stereo) to Mbox. Sound from Mbox *cannot* be played through your computer's speakers or your computer's sound output.

Connecting Headphones

On the front panel of the Mbox is a 1/4-inch jack to connect headphones, and a headphone level control to adjust headphone volume.

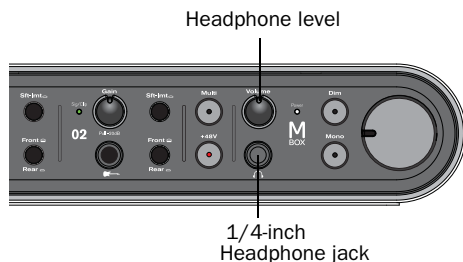

Headphone jack on front of Mbox

To connect headphones:

- Connect headphones with a 1/4-inch stereo connector (or adaptor) to the Headphone jack.

Connecting a Sound System

The Line Outputs on the back of the Mbox support 1/4-inch plugs. These connections can be balanced, TRS (Tip, Ring, Sleeve) style connectors, or unbalanced connectors. To listen to your Pro Tools session, these outputs can be connected to any amplification system: powered speakers, a home stereo system, or an audio mixer.

When connecting to a stereo system, connect the left channel (often the white plug) to Line Out Left, and right channel (often the red plug) to Line Out Right.



Home stereo systems often use RCA connectors. You can use an adaptor or a special cable to convert from the TRS or TS connectors used by Mbox to the RCA connectors on your home stereo.

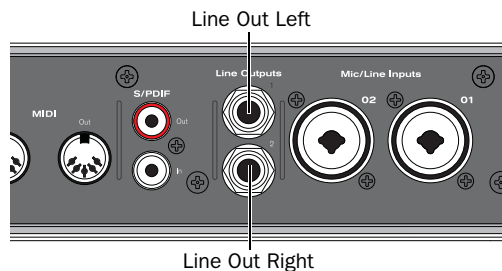

Stereo output from the Mbox (back panel)

Connecting Audio Inputs

This section describes the analog inputs available on Mbox. For information about connecting specific audio sources, see “Connecting a Microphone” on page 39, and “Connecting Instruments to the Mbox” on page 40.

Overview of Analog Inputs

Mbox inputs (sources) support microphones, guitars, keyboards, and other types of instruments. Mbox has two audio input sections, labeled Input 1 and Input 2. For stereo inputs, use Input 1 for the left input, and Input 2 for the right input.

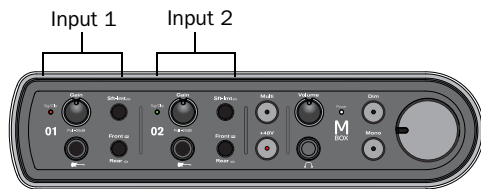

Inputs on front panel of Mbox

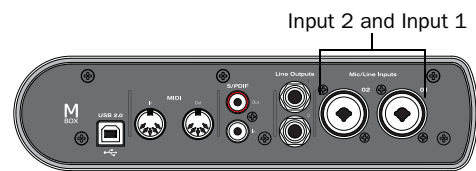

Inputs on rear panel of Mbox

The two input sections are located so that the hardware input jacks line up directly behind their corresponding input controls on the front panel. This makes it easier to locate channel input connections from the front.

Each Input section has three analog input jacks (the Mic and Line are on a single, combo jack):

Mic For XLR microphone cables.

Line (TRS) For 1/4-inch Tip-Ring-Sleeve cables from keyboards, mixers, and other line sources.

DI For 1/4-inch Tip-Sleeve cables from guitar, bass, or similar sources.

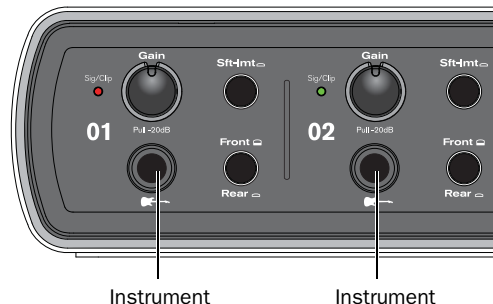

Front panel analog input connectors

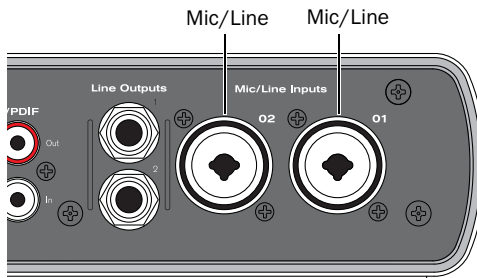

Rear panel analog input connectors

For information about connecting specific audio sources, see “Connecting a Microphone” on page 39, and “Connecting Instruments to the Mbox” on page 40.

Connecting a Microphone

Mic Cables and Connectors

Use a microphone with an XLR connector to connect the microphone to the Mbox.

The Mbox can only supply power through a microphone cable with an XLR connector. If you are not sure about the phantom power requirements for your microphone, refer to your microphone's documentation or contact the manufacturer.

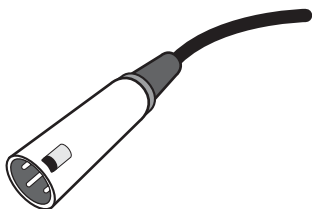

XLR connector

Phantom Power

Some microphones require power to operate. This power, called *phantom power*, is supplied either by a battery in the microphone, or through an audio interface (such as Mbox) that can supply power through the microphone cable.

Most *condenser* microphones (such as an M-Audio Solaris) require phantom power to operate. *Dynamic* microphones (such as a Shure SM57) do not require phantom power to operate, but are not harmed by it.

⚠ Although phantom power can be used safely with most microphones, it is possible to damage some ribbon microphones with it. Always turn off phantom power and wait at least ten seconds before connecting a ribbon microphone.

Using a Mic with an XLR Connector

To use a microphone that has an XLR connector:

1 Plug your microphone cable into one of the Mic/Line inputs on the back of Mbox.

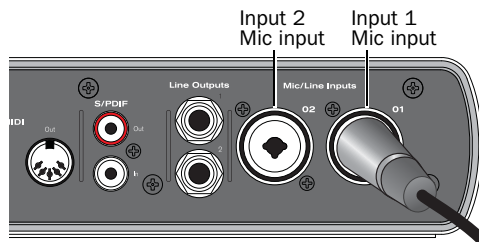

XLR connector plugged into Input 1

2 Set the Source to Rear ("in" position) by pressing the Source selector on the front of Mbox.



Input 1 Source selector

3 If your microphone requires phantom power, make sure the microphone is connected, then press the Phantom Power switch (labeled 48V) on the front of the Mbox. This switch sends 48V to *both* mic inputs. The 48V LED on the front of the Mbox will light when phantom power is being supplied.



Phantom Power switch

4 On the front of the Mbox, carefully turn the Gain control to the right to increase the input level of your microphone signal.



Gain knob for Input 1

5 If the incoming signal is too loud, pull the Gain knob out to engage the -20 dB pad.

Connecting Instruments to the Mbox

Mbox provides two input types (DI and Line) that correspond to the different signal strengths output by different types of instruments.

DI Input Instruments such as electric guitar or electric bass that usually have a lower level of output than line level instruments use the DI (“Direct Inject”) input.

Line Input Line level devices, including electronic audio sources such as mixers, samplers, keyboards, and synthesizers use the Line input.

Connecting Electric Guitar or Bass

To use a guitar with Mbox:

1 On the front of the Mbox, plug your guitar cable into one of the Instrument inputs.



Input 1 instrument input

Connecting a guitar to the 1/4-inch connector

2 On the front of the Mbox, set the source to Front by setting the input channel Source selector to the Out position (orange band is visible).



Source selector

Source selector and Gain control for Input 1

3 On the front of the Mbox, carefully turn the Gain control to the right to increase the input level of your guitar.

Connecting Keyboards and Mixers

To use a keyboard or mixer with Mbox:

1 Plug your keyboard, mixer, or other audio source into either the Input 1 or Input 2 Line (TRS) inputs on your Mbox. If your source is stereo (such as a stereo keyboard or the stereo output from a mixer), connect the left channel (often the white plug) to Input 1, and right channel (often the red plug) to Input 2.

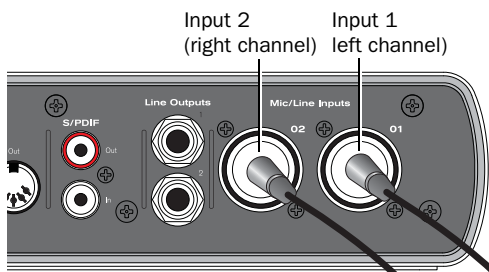

Mbox connections for line-level stereo input source

2 Set the Source to Rear (“in” position) by pressing the Source selector on the front of Mbox.

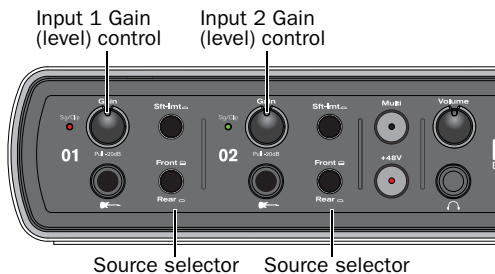

Source selector and Gain control for Inputs 1 and 2

3 Set your instrument’s volume to its optimal level. For example, the optimal level for most keyboards is between 80% and 100% of maximum volume.

4 On the front of the Mbox, carefully turn the Gain control to the right to increase the input level of your keyboard.

Digital Input and Output

Mbox provides digital inputs and outputs for S/PDIF format digital audio. The two channels of S/PDIF digital input can be used in combination with the two analog inputs (for a total of four simultaneous input channels).

Connecting Digital Devices

To connect a S/PDIF device to Mbox:

- 1 Use two 75-ohm coaxial cables with male RCA connectors on both ends (purchased separately).
- 2 Connect the device’s S/PDIF output to Mbox’s S/PDIF input port, and the device’s S/PDIF input to Mbox’s S/PDIF output port.

 To configure Mbox to record from a digital source, choose *Setups > Hardware Setup* in *Pro Tools*, then select *S/PDIF* in the *Clock Source*.

Using S/PDIF Input

To configure Pro Tools to record from a S/PDIF device:

- 1 Choose *Setups > Hardware Setup*.
- 2 Select S/PDIF from the *Clock Source* pop-up menu.
- 3 Click *OK*.
- 4 On the recording track, select the appropriate stereo or mono S/PDIF source from the track *Input* selector.

Once enabled in the *Hardware Setup* dialog, the S/PDIF inputs become active and will pass audio to Mbox.

Setting the *Clock Source* to S/PDIF is the only way to utilize S/PDIF input. Doing so lets you record or monitor up to four discrete input channels (2 analog and two S/PDIF).

MIDI Connections

The two MIDI ports on Mbox let you take advantage of all the MIDI features of Pro Tools LE, including recording and editing MIDI tracks.

If you need additional MIDI ports you can add a compatible MIDI interface. USB MIDI interfaces work effectively with Pro Tools systems on Windows or Mac. Serial MIDI interfaces are supported on Windows systems only.

⚠ Only USB MIDI interfaces are compatible with Pro Tools systems for Mac OS X. Modem-to-serial port adapters and serial MIDI devices are not supported.

To connect your MIDI device to Mbox:

- 1 Connect a standard 5-pin MIDI cable from the MIDI Out port of your device to the MIDI In port on the back of Mbox.
- 2 Connect another MIDI cable from the MIDI In port of your device to the MIDI Out port on the back of Mbox.

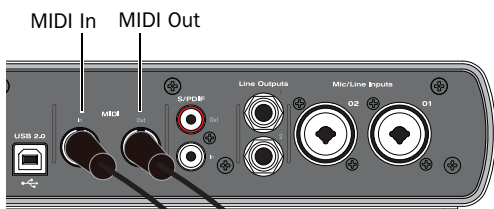

MIDI connections to Mbox

Monitoring MIDI Instruments with Mbox

If you have a MIDI instrument that has analog outputs, you can connect it to Mbox to monitor its output.

To connect your MIDI instrument for monitoring in Pro Tools:

- Connect the MIDI instrument's audio outputs to the Line (TRS) inputs on your Mbox.

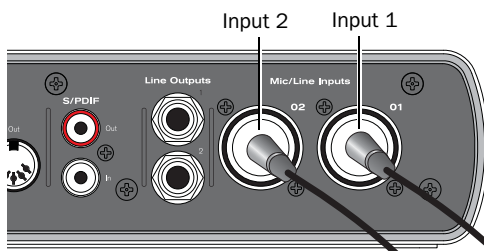

Mbox connections for line-level stereo input source

appendix a

Using the Driver Control Panel

The Mbox Driver Control Panel lets you configure settings for your audio interface for use with Pro Tools or other audio applications that support the CoreAudio Drivers (Mac) or ASIO Audio Drivers (Windows) standard.

Several features of Mbox can be accessed directly from the Mbox front panel, such as input gain, phantom power, and output levels. But there are many additional parameters that cannot be accessed from the front panel. These additional features are available to you using the included Driver Control Panel application.

To open the Driver Control Panel

- On Mac, launch System Preferences (Apple menu > System Preferences), then double-click Avid Mbox. (You can also open the Driver Control Panel from the Applications menu.)

– or –

- On Windows, choose Start > Control Panel > Mbox.



Mbox Driver Control Panel (Horizontal view shown)

To open the Driver Control Panel from Pro Tools:

1. Choose Setup > Hardware in the Edit window.
2. Click launch control panel.

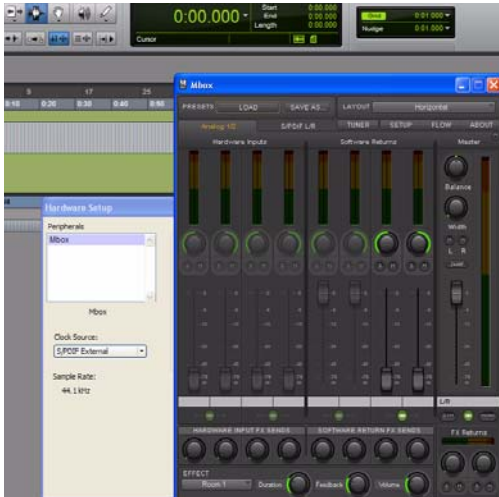

Mbox Driver Control Panel launched in a Pro Tools session

Presets

The Preset view lets you load and save Mbox Settings files, which contain all settings of the Mbox Driver Control Panel. This is useful if you'd like to save various configurations so that you do not have to manually reconfigure your system each time you work on a different type of project.

Load Button

The Load Button opens a file browser that lets you load a previously saved Settings file.

Save as...

The Save as button opens a file browser that lets you save the current settings of the Driver Control Panel to a Settings file.

Layouts

The Layout drop-down menu lets you choose what information you would like the Driver Control Panel to show, and how you would like that information to be displayed. There are four layouts to select from:

Horizontal

The Horizontal layout is the default layout. It shows all knobs, faders, meters and buttons in a layout similar to that of a mixing console. The Horizontal layout is used for all the screen captures in this chapter.

Horizontal (Meters Only)

The Meters Only layout emphasizes pre-fader hardware input and software return metering, but does not provide access to the stereo mixers.

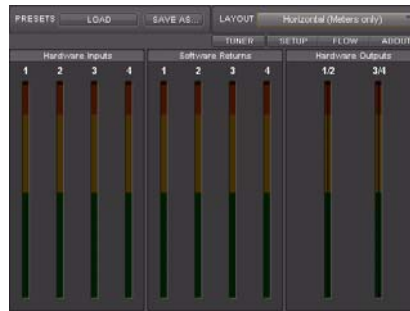

Mbox Driver Control Panel (Horizontal (Meters only) shown)

Vertical



*Mbox Driver Control Panel
(Vertical shown)*

The Vertical layout provides access to all controls and meters in a vertical window. The Vertical layout was designed for compact operation, which is convenient if you want to run it along with Pro Tools (uses far less screen real estate, but provides full functionality).

Vertical (Meters Only)



*Mbox Driver Control Panel
(Vertical (Meters only) shown)*

The Meters Only layout emphasizes pre-fader hardware input and software return metering, but does not provide access to the stereo mixers

Additional Functions

Mbox also features a variety of functions accessible through pop-up menus located at the upper-right area of the Control Panel:

- Tuner
- Setup
- Flow
- About

Tuner

The Tuner activates the tuner function of Mbox. You can also access the tuner by pressing the front panel Mono and Dim buttons simultaneously. A tuner display will appear in the center of the Driver Control Panel, and the front panel input meters will function as tuning indicators as well.

When tuning from the front panel, use the input meters (LED ladders). They are red when out of tune and green when in tune.



Setup

Setup is where you define the hardware settings of the Mbox. For example, you can set buffer size, sample rate, and clock source. Think of Setup as a quick way to customize Mbox behavior.

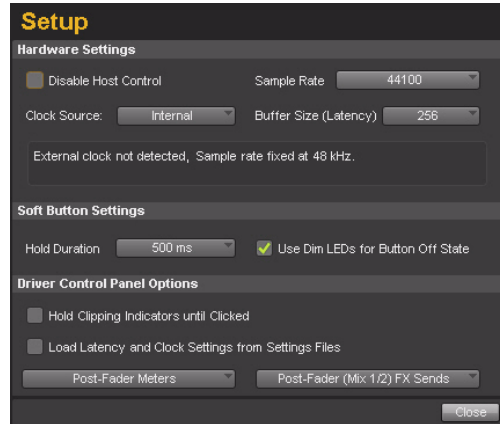

Setup pop-up menu

In the Setup window, the options are grouped in the following categories:

Hardware Settings

The parameters in this section of the Control Panel govern the operation of the interface when it is connected to a computer using a UBS cable (i.e., Hosted Mode).

This section of the Control Panel provides parameters you can set on your interface when it is connected to a computer using a UBS cable.

Disable Host Control

This setting lets you rest control of the Driver Control Panel from Pro Tools. When you launch Pro Tools, it takes control of the Driver Control Panel's first stereo mixer. If you want to obtain full manual control of the Driver Control Panel, choose this option.

 *If you want to use the Low Latency Monitoring option of Pro Tools, this option must not be checked.*

Clock Source

This setting determines the clock source to which Mbox is synchronized.

Internal If you are using Mbox by itself (i.e., without other digital devices or an external clock), select the Internal option for the interface to work properly.

S/PDIF If have connected a S/PDIF device to your Mbox and would like to use that device as the master clock source, select the S/PDIF option. This will make Mbox clock to the external device's clock.

Sample Rate

This drop-down menu sets the sample rate of Mbox. Note that when using the interface with an ASIO or CoreAudio application, the sample rate can also be determined by your audio application. This parameter may not be editable from within the Mbox Control Panel if your audio application is running. In this case, any changes to the sample rate must be made through the audio application itself. If the application does not provide a way to set the sample rate, quit the application, then change the sample rate through the Mbox Control Panel.

 *In Windows Vista, when using the Mbox WDM/MME (i.e., non-ASIO) drivers, the sample rate of the interface (and your audio software) is always determined by this drop-down menu. Your selection in this menu is the only item that will appear in your audio application. For example, if you select "44.1kHz" in this menu, your audio application's control panel will only display "44.1kHz" and you will not be able to select any other rates from within the application.*

When the sample rate is locked to an external digital clock source, the Mbox's LED is solid blue. When the sample rate is set and there is no digital clock source detected (or cannot lock to it for some reason), the LED will blink. (A message appears at the bottom of the Hardware Settings section stating that: "External clock not detected, Audio Streaming is Disabled.").

Buffer Size (Windows only)

This menu sets the size of the input and output buffers on Mbox.

Buffers are used to help keep audio hardware and software running smoothly by processing audio in groups of samples rather than one sample at a time. Due to variations between computer hardware and software, it is impossible to recommend a single optimum setting for all systems. It may be necessary to experiment with various settings until you find the best buffer size for your system.

The goal of setting a buffer size is to reduce it as much as possible without hearing any clicks, pops, or other glitches. If the buffer size is too small, the computer will not be able to make all the required audio calculations on time and you will hear pops, clicks, and stuttering in your audio streams. On the other hand, if the buffer size

is set too high, your computer will process audio without incident, but your software will feel sluggish and unresponsive. See “Hardware Buffer Size” on page 18.

To find your system’s optimum buffer size setting, begin with a high setting and gradually reduce the size until you begin to hear clicks, pops, or other audible glitches in your audio. Then, raise the buffer size setting until these glitches disappear. You may need to stop playing audio any time you change this setting and certain applications will require you to re-launch the program before the new buffer size settings become active.

 *This menu only appears on Windows systems. Most Mac OS X applications allow to change the buffer size from within the audio application itself. Please see your audio application’s user guide to learn how to change this setting.*

Soft Button Settings

The Mbox has four “Soft” buttons: Multi, +48v, Mono, and Dim.

Hold Duration

This pop-up menu gives you four choices of Press and Hold duration for all soft buttons on the front of the Mbox. Choose between 250 msec, 500 msec, 750 msec, and 1 sec.

Use Dim LEDs for Button off State

Checking this option gives you a dim LED for all the soft buttons that are off (so you can still discern the LED in the dark).

Driver Control Panel Options

Hold Clipping Indicators until Clicked

The top section of the meters (or right section for horizontal meters) of the Driver Control Panel feature a red clipping indicator. When this option is selected, the clipping indicators will remain lit until they are clicked.

Load Latency and Clock Settings from Settings Files

When this option is selected, the clock source and buffer settings are recalled when loading a setting file

Post-Fader Meters

When this option is selected, fader positions will affect the meters. Post-Fader Meters mean the meter indicate post-fader levels.

Pre-Fader Meters

When this option is selected, the meters display the level of a signal before it passes the fader. This allows signal levels to be displayed regardless of the fader positions within the stereo mix (in other words, a fader can be all the way down and no sound will be heard from the mixer’s output, but you can still see if there is any activity on that input).

FX Sends Mode

Pre-Fader FX Sends

When Pre-Fader FX Sends is selected, the full audio signal will be sent to the FX Sends, regardless of the position of the Channel Faders of stereo mix 1–2.

Post-Fader (Mix 1/2) FX Sends

When Post-Fader (Mix 1/2) is selected, the audio signal level being sent to the FX Sends will be affected by the position of the Channel Faders of Stereo Mix 1.

Flow

Clicking the Flow pop-up menu opens a display showing the signal flow from the inputs to the outputs of Mbox. This is a useful reference for understanding the path of an audio signal flowing through Mbox.

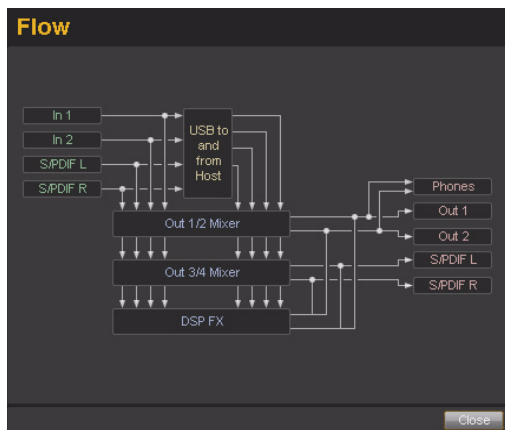

About

The About pop-up menu allows you to view the firmware version of the Mbox hardware, and the package version of the Mbox driver installer.



Viewing Firmware and Installer Information

Directly above the status indicators, you can view the firmware version of the Mbox Mini hardware, and the package version of the Mbox driver installer.

Accessing the Web Links

Along the bottom-right of the Driver Control Panel you can easily access helpful online resources on our Avid website (www.avid.com) by clicking on the following pop-up menus:

- Manual
- Updates
- Support
- FAQs
- Register

 Clicking on any of the “Web links” will open your web browser. Your computer must have Internet access for these pages to load.

Stereo Mixes

This 8-input, 4-output mixer allows you to create two different stereo mixes from 8 input sources consisting of any of the hardware inputs (i.e., analog and digital inputs) and software returns (software outputs). This allows you to set up near-zero latency cue mixes in which the performers hear a “customized” mix while recording.

It is important to note that any changes made to the stereo mix will only affect what is audible from the mixer’s outputs—the stereo mix does not affect the signals that are sent to Pro Tools for recording. For example, if you are recording a vocalist and he/she tells you to turn up the vocal track so they can hear themselves better, you can increase the vocalist’s microphone channel in the stereo mix. This will make the vocal part louder in the vocalist’s headphones, but it will still be recorded into Pro Tools at the volume determined by the front panel Gain Adjustment Knob.

The stereo is set up like a standard mixing console: There are 8 input channels, each with its own volume fader, pan and aux send knobs, solo, and mute buttons, as well as a master output section with its own faders and mute button.

A pair of channels can be linked together by clicking the link icon between the two channels. Linking channels allows you to adjust mute, solo, and fader settings simultaneously by modifying parameters on either one of the linked channels. However, linking two channels will not have any effect on their Pan controls, which are always made on a per-channel basis.

The stereo mix features multi-segment meters to show input channel levels (directly above each channel) and main mixer output levels (at the top right of the mixer). The peak hold indication time as well as pre/post fader metering operation can be set from the Settings Tab of the Control Panel. The clip indicators can be reset by clicking on the meter itself.

Keep in mind that setting or adjusting the stereo mix will not affect the signal that is recorded into Pro Tools. For example, you’ll still be able to record a channel while its corresponding stereo mix channel is muted. You won’t hear the part through the stereo mix as it is being recorded, but it will still record into Pro Tools and play back properly.

Using the Stereo Mix Section

The stereo mix section is located in the main view of the Driver Control Panel and is divided into four main sections:

- Hardware Inputs
- Software Returns
- Effects
- Master

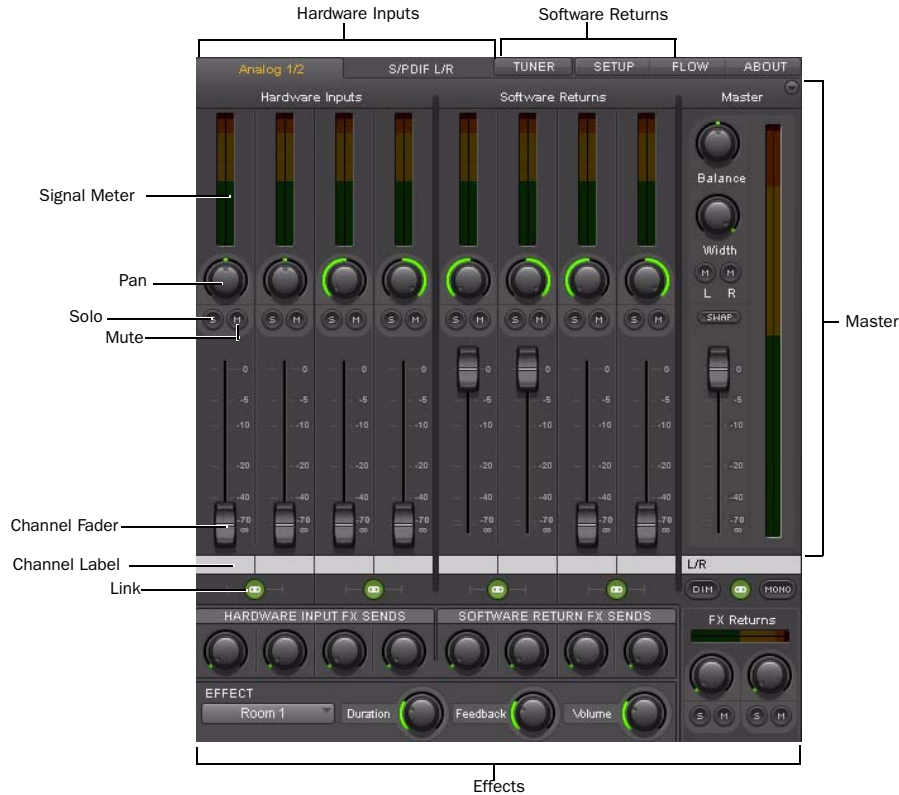

Hardware Inputs

The Hardware Inputs section is where the Mic/Line and Instrument inputs are monitored, as well as the S/PDIF input of Mbox. Hardware Inputs 1–2 are the analog inputs, and Hardware Inputs 3–4 are the S/PDIF input L/R.

Software Returns

The Software Returns section is where the audio coming back from Pro Tools (or other audio application) is monitored. Software Returns 1 and 2 will be the default stereo output from Pro Tools.

Pan

The Pan knobs control the position of a channel's audio signal in the stereo image of the stereo mix (double-click the knob to return pan to center).

Solo

Each Solo button lets audio be monitored for the channel of which it is a part, while simultaneously muting all other Hardware Input channels and Software Returns (except for those that also have their Solo buttons activated).

Mute

The Mute buttons are used to individually turn off audio monitoring for each channel in the stereo mix.

Channel Faders

The Channel Faders control the monitoring volume level of each channel in the stereo mix.

Channel Labels

By default, the Channel Labels show the input name of each channel (1–8), except for the Master fader pair (which is labeled L/R by default).

Clicking on a Channel Label gives you a cursor, allowing you to type in your own custom channel name (such as “guitar,” “vocals,” etc.).

The Channel Labels also display the signal level (in dB) while a fader is being adjusted.

Link

The Link buttons connect stereo pairs of knobs or faders (and also links the corresponding FX Send knobs), so that adjusting either channel (left/right) adjusts the other side identically.



 *Pan controls are unaffected by linking two channels.*

Effects

The Effects section is where you set up “send-and-return” configurations, and select the effects that you apply to the Hardware Inputs and/or Software Returns.

Hardware Input FX Sends

FX Sends are shared by all Stereo Mixes, unless “Post-Fader Stereo Mix 1” is chosen in the Setup pop-up menu.

Software Return FX Sends

FX Sends are shared by all Stereo Mixes, unless “Post-Fader Stereo Mix 1” is chosen in the Setup pop-up menu.

FX Returns

These knobs control how much of the Effect audio output will be mixed in with the monitor signal Master L/R outputs. Unlike sends, FX Returns are individually adjustable for each stereo mix.

The Clip LED will show clipping if the input to the FX is clipping and if the output is clipping (the rest of the meter is just output).

Effect

The Effect drop-down menu is used to select the effect to be applied to the Hardware Inputs and/or Software Returns. There are five available reverb types: Three room reverbs and two hall reverbs, delay, and echo. These effects can be customized by using the following three controls:

Duration This knob controls decay time (for the reverbs) or delay time (for delay and echo).

Feedback This knob controls the number of repeats for the delay and echo effects. It does not affect the reverbs.

Volume This knob controls the effects output level being sent to the FX Returns.

Master

The Master section is for monitoring the main mixer output. This output can be routed to any hardware output. Each Stereo Mix includes master section with several controls:

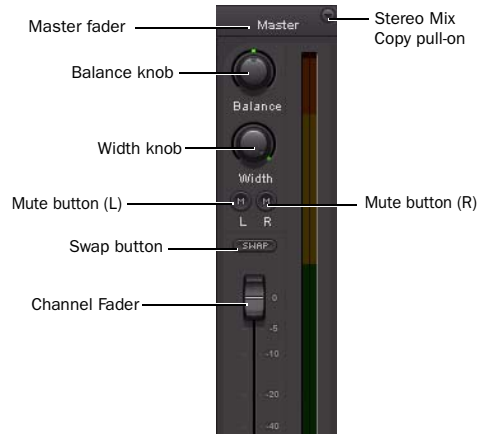

Master Fader Adjusts the overall level of the stereo mix.

Balance Knob Adjusts the left/right balance of the stereo mix (double-click the knob to return it to center).

Width Knob Adjusts the width of the stereo image, where fully counter-clockwise is mono, and fully clockwise is full stereo (double-click the knob to return it to center).

Mute Buttons Mutes the left and/or right side of the stereo mix.

Swap Button Swaps the stereo image, making the left channel play out the Right output, and the right channel play out the Left output.

Link Button Links the FXReturns section and the mute buttons.

Master Meters Lets you have a visual representation of the audio signal being fed to the associated hardware output pair.

Stereo Mix Copy Lets you copy the settings of the current stereo mix to one of the other stereo mixes.

Status Indicators

Along the bottom-left of the Driver Control Panel are the following status indicators:

Hardware Connected

This tells you the status of the hardware; if a properly installed, powered-on Mbox is connected to the computer.

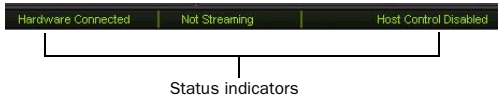

Streaming

This indicates if audio from a Digital Audio Workstation or a media player (such as Pro Tools or Windows Media Player) is currently streaming audio to the Mbox.

Host Control Enabled

If an application such as Pro Tools has control over the Driver Control Panel, then “Host Control Enabled” displays.

appendix b

Using the Multi Button

The Multi button on the front panel of the Mbox can be assigned to easily execute several functions in Pro Tools including (but not limited to):

- Add Track
- Start/Stop Record
- Tap Tempo
- Locating to Next/Previous Marker
- Save Session



Mbox (Multi button shown)

You can use the Multi button to do these and other common tasks with a single button instead of using on-screen menu commands. By pressing the Multi button two different ways (Press and Release, Press and Hold) you can perform two functions with one button.

Using the Multi Button

In the Hardware Setup dialog, Pro Tools lets you set three Multi button parameters for your Mbox using the “Multi Button Function” pane. (You can also launch the Driver Control Panel from here).

 *For more information on the Driver Control Panel, see Appendix A, “Using the Driver Control Panel.”.*

The Multi Button Function includes the following options:

Press and Release Displays the options available for Press and Release mode.

Press and Hold Displays the options available for Press and Hold mode.

Duration Gives four time duration options for Press and Hold button.

Launch Control Panel Launches Driver Control Panel.

To use the Multi Button Function pane and configure its parameters (example):

- 1 Launch Pro Tools.
- 2 Choose Track > New and create 1 Mono audio track.



You need to have at least one track available in a session to use the Add Last Track and Add Selected Track functions.

- 3 Choose Setup > Hardware.
- 4 From the Press and Release list, select Start/Stop Record (the default).
- 5 From the Press and Hold list, select Add Selected Tracks (the default).

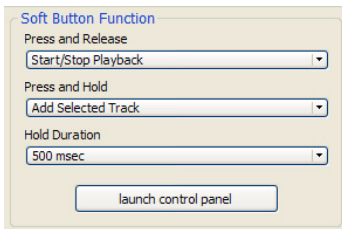

Multi Button Function pane (Shown in Hardware Setup dialog)

- 6 From the Hold Duration list, select 500 msec (the default).
- 7 Go to the Edit Window and select the track you just created.
- 8 Press and hold the Multi button for 500 msec, then release. A new track is added in Record Enable mode.
- 9 Press and immediately release the Multi button. The track begins recording.

This is just one example of how easy it is to use the Multi button if you want to quickly throw down tracks and record. But you can personalize the Multi button settings to fit any audio workflow that works for you.

Press and Release Options

When you click on the Press and Release list, a pop-up menu provides access to the following options:

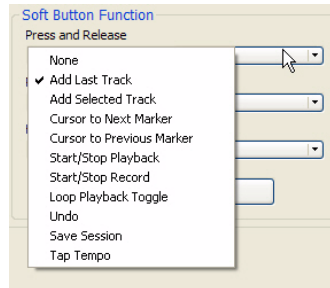

None No function is selected in this mode.

Add Last Track Adds the last track type that you created in the session. Say you have created two Audio tracks in a session. It will add another mono Audio track.

Add Selected Track Adds whatever tracks that you have selected in a session. Say you have selected two Audio tracks in a session. It will add another two Audio tracks.

Cursor to Next Marker Each time the button is pressed and released, the transport will locate to the *next* marker location.

Cursor to Previous Marker Each time the button is pressed and released, the transport will locate to the *previous* marker location.

Start/Stop Playback Each time the button is pressed and released, it starts/stops playing back the session.

Start/Stop Record Each time the button is pressed and released, it starts/stops recording.

Loop Playback Toggle Each time the button is pressed and released, the Loop Playback mode is toggled between enabled and disabled.

Undo Each time the button is pressed and released, it undoes that last operation you performed in Pro Tools. (Same as the Undo command from the Pro Tools menu)

Save Session Each time the Multi button is pressed and released, it saves the session.

Tap Tempo The Multi button can be tapped to adjust the session tempo. Tapping tempo will cause Pro Tools to come out of Conductor mode and match its tempo to the tapped tempo. If Pro Tools is already in Manual Tempo mode, the session will automatically adjust its tempo to match the value created by the Tap Tempo function.

Press and Hold Options

When you click on the Press and Hold list, a pop-up menu provides access to the following options:

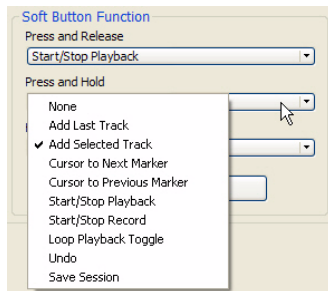

None No function is selected in this mode.

Add Last Track Adds whatever the last track type was that you created in the session. Say you have five types of tracks in your session but the most recent track you created was 1 Mono Audio Track, in Samples. It will add another 1 Mono Audio Track, in Samples.

Add Selected Track Adds whatever tracks that you have selected in a session. Say you have selected two Audio tracks in a session. It will add another two Audio tracks.

Cursor to Next Marker Each time the button is held and released, the transport will locate to the *next* marker location.

Cursor to Previous Marker Each time the button is held and released, the transport will locate to the *previous* marker location.

Start/Stop Playback Each time the button is held and released, it starts/stops playing back the session.

Start/Stop Record Each time the button is held and released, it starts/stops recording.

Loop Playback Toggle Each time the button is held and released, the Loop Playback mode is toggled between enabled and disabled.

Undo Each time the button is held and released, it undoes that last operation you performed in Pro Tools. (Same as the Undo command from the Pro Tools menu)

Save Session Each time the Multi button is held and released, it saves the session.

Hold Duration Options

When you click on the Hold Duration list, a drop-down menu provides access to the following options:

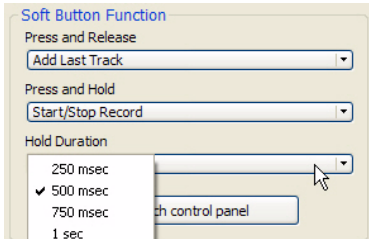

Hold Duration There are four choices of Hold Duration (250 msec, 500 msec, 750 msec, and 1 sec), which is the amount of time you choose to hold the Multi button down in Press and Hold mode. The default is 500 msec.

appendix c

Configuring AMS (Mac OS X Only)

Audio MIDI Setup

Pro Tools recognizes the ports on your MIDI interface as generic ports. With Mac OS X, you use Apple's Audio MIDI Setup (AMS) utility to identify external MIDI devices connected to your MIDI interface and configure your MIDI studio for use with Pro Tools.

To configure your MIDI studio in AMS:

- 1 Do one of the following:
 - Launch Audio MIDI Setup (located in Macintosh HD/Applications/Utilities).
 - or –
 - In Pro Tools, choose Setup > MIDI > MIDI Studio. (If the MIDI Studio window is not open, click Window > Show MIDI Window.)

- 2 Click MIDI Devices. AMS scans your system for connected MIDI interfaces. If your MIDI interface is properly connected, it appears in the window with each of its ports numbered.

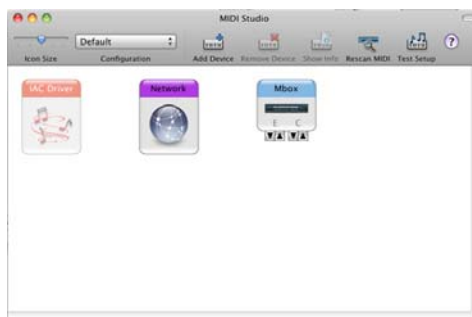

Audio MIDI Setup (MIDI Devices)

- 3 For any MIDI devices connected to the MIDI interface, click Add Device. A new external device icon with the default MIDI keyboard image will appear.
- 4 Drag the new device icon to a convenient location within the window.

5 Connect the MIDI device to the MIDI interface by clicking the arrow for the appropriate output port of the device and dragging a connection or “cable” to the input arrow of the corresponding port of the MIDI interface.

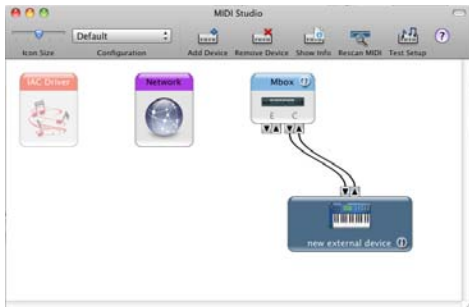

Making MIDI input and output connections

6 Click the arrow for the appropriate input port of the device and drag a cable to the output arrow of the corresponding port of the MIDI interface.

 To remove a connection, select the cable and press Delete. To delete all connections, click Clear Cables.

7 Repeat steps 3–6 for each MIDI device in your MIDI setup.

To configure an external MIDI device:

1 Select the external device icon and click Show Info (or double-click the new device icon).



External Device Icon

2 Select a manufacturer and model for the new device from the corresponding pop-up menus. (If the Manufacturer and Model pop-up menus do not provide a name for your particular device, you can type a name.)



Naming a new MIDI device

 For Manufacturer and Model names, AMS refers to one or more files with the suffix “.middev” in the directory Root/Library/Audio/MIDI Devices. Pro Tools installs a file that contains information for many commercially available MIDI devices, named “Digidesign Device List.middev.” If the Manufacturer or Model names for any of your external MIDI devices is not available in the AMS Manufacturer and Model pop-up menus, you can add them by editing the .middev file in any text editor (such as TextEdit).

3 Click the More Information arrow to expand the dialog, then enable the appropriate MIDI channels (1–16) for the Transmits and Receives options. (These determine which channels the device will use to send and receive MIDI.)

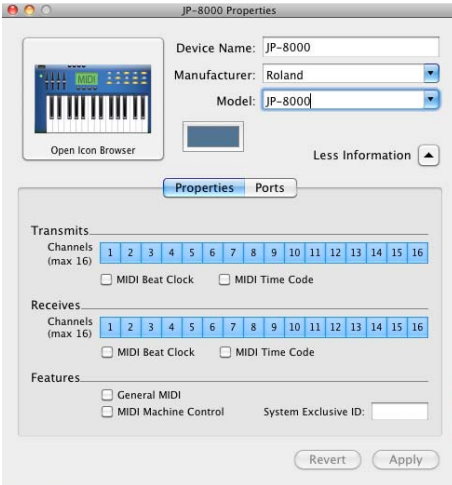

Enabling MIDI channels

4 Click the device image. The window expands to show images for various MIDI devices (such as keyboards, modules, interfaces, and mixers). Select an icon for your device.

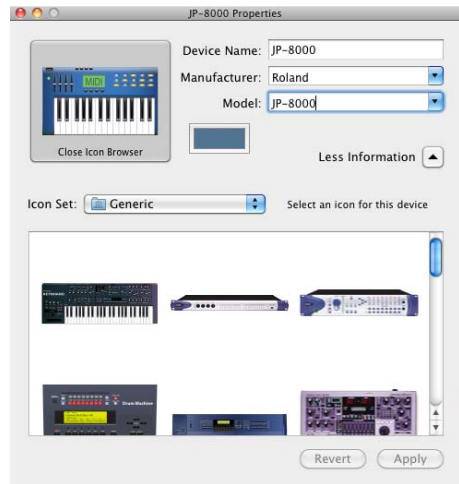

Selecting a device icon

 To use your own custom icons, you can place TIFF image files in `/Library/Audio/MIDI Devices/Generic/Images`, and they will appear as choices in the AMS device window.

5 Click OK.

The device names you enter appear as MIDI input and output choices in Pro Tools.

MIDI Patch Name Support

Pro Tools supports XML (Extensible Markup Language) for storing and importing patch names for you external MIDI devices. Pro Tools installs MIDI patch name files (.midnam) for the factory default patch names of many common MIDI devices. These files reside in directories, sorted by manufacturer, in Macintosh HD/Library/Audio/MIDI Patch Names/Digidesign.

To import MIDI patch names into Pro Tools:

- 1 Verify the MIDI Device name in the Audio MIDI Setup window (see “Audio MIDI Setup” on page 59).
- 2 Verify the Instrument or MIDI track output is correctly assigned to the MIDI device.
- 3 Click the Instrument or MIDI track Patch Select button.



Patch Select button
(Edit window)



Patch Select button
(Mix window)

Patch Select button

- 4 In the Patch Select dialog, click Change.

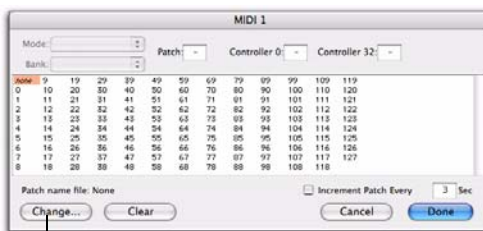

Change button

Patch Select dialog

- 5 In the Open dialog, navigate to /Library/Audio/MIDI Patch Names/Digidesign/<name of manufacturer>, and select the MIDI Patch Name file (.midnam) for the MIDI device.
- 6 Click Open.

The Patch Select dialog is populated with patch names and the Patch Name Bank pop-up menu appears in the upper left hand corner of the window.

Once patch names have been imported into Pro Tools, they are available for that MIDI device in all sessions.

To clear patch names:

- In the Patch Select dialog, click Clear, and then click Done.



MIDI patch name files (.midnam) can be edited in any text editor, or you can use third-party patch librarian and editor software to create your own custom patch names.

appendix d

Configuring MIDI Studio Setup (Windows Only)

MIDI Studio Setup

MIDI Studio Setup (MSS) lets you configure the MIDI controllers and sound modules that are connected to your system, and control the routing of MIDI data between your MIDI equipment and Pro Tools.

MSS automatically finds MIDI interfaces, and lets you specify a custom name for each of the MIDI ports within the MIDI Studio Setup document.

MSS also supports XML-based patch file names for storing and importing patch names for your external MIDI devices.

Entire MIDI Studio Setup configurations created within MSS can be imported and exported.

MIDI Studio Setup Window

The MIDI Studio Setup window is organized into three sections. Interface controls are at the top of the window. All the currently defined instruments are displayed in the Instrument Name list on the left side of the window. A detailed view of MIDI parameters is shown in the Properties section on the right.

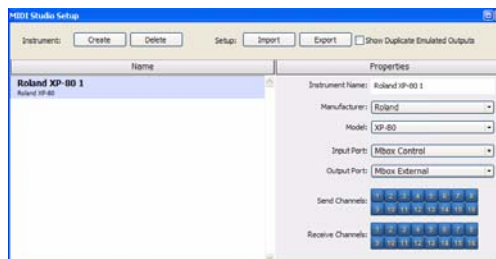

MIDI Studio Setup Properties section

Interface Controls

Create Adds a new instrument to the Instrument Name list.

Delete Deletes the instrument or instruments selected in the Instrument Name list.

Import Imports an existing MIDI Studio Setup file.

Export Exports the current MIDI Studio Setup file.

Show Duplicate Emulated Ports When this option is selected and you are using a MIDI interface that supports timestamping (such as MIDI I/O), in addition to the MIDI ports on Mbox, the MIDI Studio setup window shows both the DirectMusic time-stamped output ports, and non-stamped duplicate emulated output ports.

 *Some MIDI Interfaces will not properly load or unload their drivers unless you quit and re-launch Pro Tools. Check the documentation that came with your MIDI interface for more information.*

Instrument List

The Instrument list contains all the currently defined instruments. Selecting an instrument in the list displays that instrument's properties in the Properties section of the window.

Properties Section

The Properties section lets you edit information for new instruments, or instrument currently selected in the Instrument list.

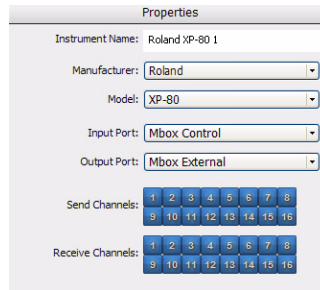

MIDI Studio Setup Properties section

When a previously defined instrument is selected in the Instrument list, the Properties section changes to reflect the properties of the selected instrument.

To define an instrument with MIDI Studio Setup:

- 1 Choose Setup > MIDI > MIDI Studio.
- 2 Click Create.
- 3 In the Instrument Name field, type the name of your instrument, and press Enter.

 *If you do not enter an instrument name, the Instrument Name field will automatically inherit information from the Manufacturer and Model pop-up menu.*

4 Set a manufacturer and model for the new device from the corresponding pop-up menus. If the Manufacturer and Model pop-up menus do not provide a name for your particular device, select None.

5 From the Input pop-up menu, select the input port on your MIDI interface that is connected to the MIDI Out of your instrument.

6 From the Output pop-up menu, select the output port on your MIDI interface that is connected to the MIDI In of your instrument.

7 Enable the appropriate MIDI channels (1–16) for the Send Channels and Receive Channels options (These determine which channels send and receive MIDI.)

Instrument Name

The Instrument Name field shows the user-definable instrument name for the currently selected instrument.

Manufacturer

The Manufacturer pop-up menu provides a list of MIDI equipment manufacturers. This list is derived from the XML-based MIDI device files.

 For more information, see “MIDI Patch Name Support” on page 65.

Model

The Model pop-up menu provides a list of MIDI devices, filtered by the manufacturer name. This list is derived from the XML-based MIDI device files provided with your Pro Tools installation.

 For more information, see “MIDI Patch Name Support” on page 65.

Input Port

The Input Port pop-up menu displays a list of available MIDI interface input ports. Inputs will include Mbox and any additional MIDI interfaces enabled on your system. The MIDI inter-

face port that is set and displayed here is the port through which MIDI data is sent from the external MIDI device specified in the Instrument Name field into your MIDI interface.

 If you set the input port to None, the defined instrument will not appear as a choice in a MIDI Input selector.

Output Port

The Output Port pop-up menu displays a list of available MIDI interface output ports. The port set and displayed here is the port through which MIDI data is sent from your MIDI interface to the MIDI device specified in the Instrument Name field.

 If you set the output port to None, the defined instrument will not appear as a choice in a MIDI Output selector.

Send Channels

The Send Channels grid sets the send channels for the MIDI device specified in the Instrument Name field.

Receive Channels

The Receive Channels grid sets the receive channels for the MIDI device specified in the Instrument Name field.

MIDI Patch Name Support

Pro Tools supports XML (Extensible Markup Language) for storing and importing patch names for your external MIDI devices. Pro Tools installs MIDI patch name files (.midnam) for the factory default patch names of many common MIDI devices. These files reside in directories, sorted by manufacturer, in C:\Program Files\Common Files\Digidesign\MIDI Patch Names\Digidesign.

To import MIDI patch names into Pro Tools:

- 1 Verify the MIDI Device name in the MIDI Studio Setup window (see “MIDI Studio Setup” on page 63).
- 2 Verify the Instrument or MIDI track output is correctly assigned to the MIDI device.
- 3 Click the Instrument or MIDI track Patch Select button.



Patch Select button (Edit window)

Patch Select button (Mix window)

Patch Select button

- 4 In the Patch Select dialog, click Change.

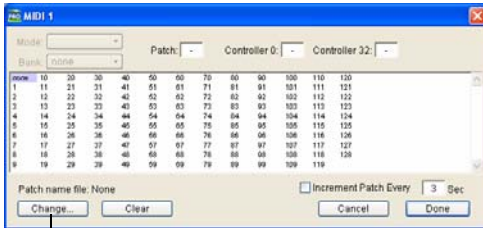

Change button

Patch Select dialog

- 5 In the Open dialog, navigate to C:\Program Files\Common Files\Digidesign\MIDI Patch Names\Digidesign\<name of manufacturer>, and select the MIDI Patch Name file (.midnam) for the MIDI device.

- 6 Click Open.

The Patch Select dialog is populated with patch names and the Patch Name Bank pop-up menu appears in the upper left hand corner of the window.

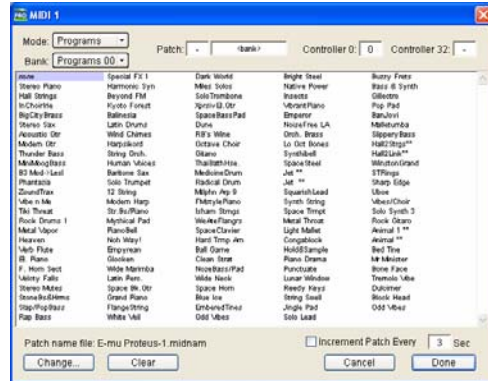

Patch Select dialog with patch names

Once patch names have been imported into Pro Tools, they are available for that MIDI device in all sessions.

To clear patch names:

- In the Patch Select dialog, click Clear and then click Done.

MIDI patch name files (.midnam) can be edited in any text editor, or you can use third-party patch librarian and editor software to create your own custom patch names.

Hard Drive Configuration and Maintenance

It is recommended that you start with a newly formatted external or secondary internal audio drive. You should also periodically defragment your audio drive to ensure continued system performance.

 *Always back up any important data on your drive before formatting it, as it will erase all data on the drive.*

Avoid Recording to the System Drive

Recording to your system drive is not recommended. Recording and playback on a system drive may result in lower track counts or fewer plug-ins.

Supported Drive Formats and Drive Types

Drive Formats

Mac Mac systems should use drives formatted with HFS+ or HFS file system only.

 *HFS drives are supported as Transfer drives only.*

Windows Windows XP systems should use drives formatted as NTFS only.

 *Windows systems can also support Mac drives formatted with HFS+ system (also commonly referred to as Mac OS Extended). Refer to the Pro Tools Reference Guide for more information (Help > Pro Tools Reference Guide).*

Hard drive performance depends on factors including system configuration, number of tracks, session sample rate, density of edits, and the use of crossfades and other processes such as Beat Detective in a session.

For complete hard drive requirements, visit our website (www.avid.com).

FireWire Hard Drives

Avid recommends qualified FireWire drives and (on Windows systems) a qualified FireWire host adapter.

For complete information on track count and the supported number and configuration of FireWire drives, visit our website (www.avid.com)

ATA/SATA Hard Drives

A qualified internal ATA/SATA drive may be used as a dedicated audio drive.

For complete information on track count with internal drives, refer to our website (www.avid.com).

SCSI Hard Drives

Avid recommends qualified SCSI hard drives and a qualified SCSI host bus adapter (HBA) card or (on Windows systems) a qualified built-in SCSI HBA connector on the motherboard.

For complete information on track count and the supported number and configuration of SCSI drives, visit our website (www.avid.com).

Formatting an Audio Drive

Formatting Mac Audio Drives

For optimum performance, audio drives should be formatted as Mac OS Extended (Journaled).

To format an audio drive:

1 Launch the Disk Utility application, located in Macintosh HD/Applications/Utilities.

2 Click the Erase tab.

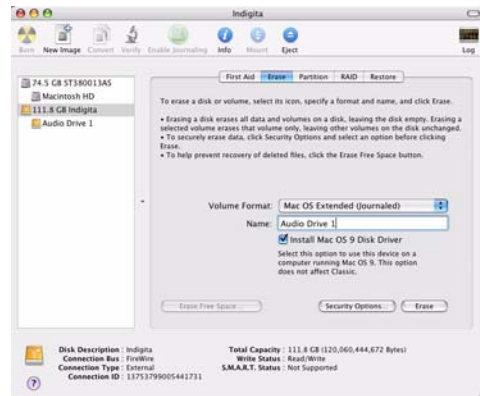

Disk Utility (Mac OS X)

3 Select the drive you want to initialize in the column on the left side of the window.

4 Choose the Mac OS Extended (Journaled) format.

⚠ Do not choose the “Case-Sensitive” format option. Pro Tools will not operate properly with case-sensitive formatted drives.

5 Type a name for the new volume.

6 If you plan to connect the drive to a Mac OS 9 computer, select Install Mac OS 9 Drivers (Mac OS 9 options only appear in 10.5 or below).

7 Click Erase.

The drive appears on the Desktop with the new volume name.

Formatting Windows Audio Drives

For optimal performance, audio drives should be formatted as NTFS.

⚠ Pro Tools only supports Basic drive types. Do not convert the drive to a Dynamic type.

To format an audio drive (Windows 7, Windows Vista, and Windows XP):

- 1 Right-click Computer (Windows 7, Windows Vista) or My Computer (Windows XP) and choose Manage.
- 2 Under Storage, choose Disk Management.

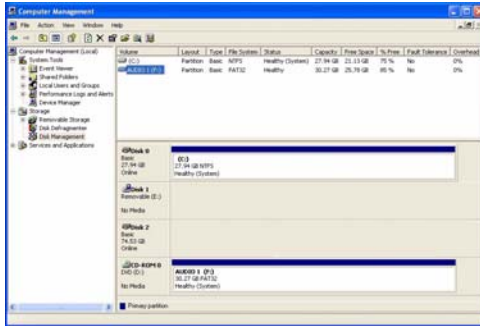

Disk Management window (Windows XP)

- 3 If the volume is “Healthy,” do the following:

 *Healthy volumes are volumes that have previously been partitioned and formatted.*

- In the Disk Management window, right-click the hard drive you will use for audio and choose Format.
- In the Format window, name the volume.
- Choose a file system. For optimum performance, audio drives should be formatted as NTFS.
- Select Perform a quick format.
- Make sure Enable file and folder compression is not selected.
- Set the Allocation unit size to Default.
- Click OK.

- 4 If the volume is “Unallocated,” do the following:

- In the Disk Management window, Right-click the hard drive you will use for audio and choose New Partition.

- In the New Partition Wizard window, click Next.
- When prompted, select the partition type.

 *Avid recommends using Primary partitions, instead of Extended partitions.*

- Follow the on-screen instructions to select a partition size and other partition settings.
- When prompted, choose a file system. For optimum performance, audio drives should be formatted as NTFS.
- Select Perform a quick format.
- Make sure Enable file and folder compression is not selected.
- Set the Allocation unit size to Default.
- Click OK.

Partitioning Drives

Partitioning creates a logical volume or volumes on a physical drive, almost as if you were creating virtual hard drives. Partitions can then be formatted with the appropriate file system (NTFS for Windows, HFS+ for Mac).

 *Mac OS allows drives larger than 4096 MB to be seen as whole volumes. Drives must be initialized with a disk utility that recognizes the 2 terabyte limit. Single Pro Tools audio files cannot exceed 3.4 GB in size.*

 *Windows XP allows drives formatted with the NTFS file system to be seen as whole volumes. Single Pro Tools audio files cannot exceed 3.4 GB in size.*

Seek Times on Partitioned Drives

Seek times are actually faster on partitioned drives (assuming that reads and writes are performed on a single partition), since the heads only have to seek within the partition boundaries, rather than the whole capacity of the drive.

Smaller partitions perform faster than larger partitions, but this comes at the expense of contiguous storage space. When you partition a drive, you will need to find the compromise that best suits your performance and storage requirements.

⚠ *Avoid distributing audio files within a session over different partitions on the same drive since this will adversely affect drive performance.*

Defragmenting an Audio Drive

Mac Systems

When working with larger files (such as video), you can limit fragmentation by backing up your important files to another disk, erasing the files from the original hard disk, then copying the files back, instead of doing a defragmentation.

Window Systems

Periodically *defragment* audio drives to maintain system performance.

For maximum recording and playback efficiency, data should be written to your hard drive in a contiguous fashion—minimizing the seek requirements to play back the data. Unfortunately, your computer can't always store the sound files in this way and must write to disk wherever it can find space.

In multitrack recording, audio tracks are written in discrete files, spaced evenly across the disk. While fragmentation of individual files may be zero, the tracks may be far enough apart that playback will still be very seek-intensive. Also, the remaining free space on the disk will be discontinuous, increasing the likelihood of file fragmentation on subsequent record passes.

Increased fragmentation increases the chance of disk errors, which can interfere with playback of audio, and result in performance errors.



On Windows, to avoid fragmentation, format drives with higher cluster sizes (such as 32K).

Optimizing (Defragmenting) Drives

To prevent fragmentation, you can optimize your drive, which rearranges your files into a contiguous format. Most optimizing software lets you run a check on a drive to find out the percentage of fragmentation. If your drive shows moderate to heavy fragmentation, you should consider optimizing it.

If you use your system for intensive editing, or if you frequently delete audio or fade files from your hard drive, you may need to optimize your drives on a weekly basis, or even every few days, since it doesn't take long for even a large hard drive to become fragmented.

Backing Up Data Before Optimizing

Since your files will be rewritten by the optimization process, always make a backup copy of the data on your hard drive before you optimize it. You should also use a hard drive utility to find and repair any problems before optimizing data or re-initializing your drives. If there is any damage to your hard drive's directories prior to optimizing, serious data loss may result.

Defragmenting Windows Audio Drives

To defragment an audio drive (Windows 7 and Windows Vista):

- 1 Click Start.
- 2 Type “disk defragmenter” in the search field at the bottom. “Disk Defragmenter” should appear at the top of the search results.
- 3 Click the Disk Defragmenter.
- 4 Click the Defragment disk button (Windows 7) or the Defragment now button (Windows Vista). Follow the on-screen instructions.
- 5 When defragmenting is complete, close the Disk Defragmenter window.

 *In Windows 7 you can Ctrl-Click on the drive names to select multiple drives to defragment, and once more than one drive is selected, the button changes to “Defragment disks.”*

 *The “Defragment Now” (Vista only) command defragments all your hard drives. This can take a lot of time, especially on systems with multiple drives.*

Advanced users can use the command line tool `Defrag.exe` to defragment individual drives. See your Windows Vista documentation for more information.

To defragment an audio drive (Windows XP):

- 1 Right-click My Computer and choose Manage.
- 2 Under Storage, choose Disk Defragmenter.
- 3 In the Disk Defragmenter window, choose the drive you want to defragment
- 4 Click the Defragment button and follow the on-screen instructions.

- 5 When defragmenting is complete, close the Computer Management window.

Using Mac Drives on Windows Systems

Pro Tools for Windows lets you record and play back sessions directly from a Mac-formatted (HFS+) drive connected to a Windows system. This functionality requires that all Mac session and audio files be stored on Mac-formatted drives.

During Pro Tools installation, make sure to select the Mac HFS+ Disk Support option. This option lets your Pro Tools system read, write, record, and play back using Mac-formatted HFS+ disks.

 *For information on sharing sessions between Mac and Windows systems, see the Pro Tools Reference Guide (Help > Pro Tools Reference Guide).*

Formatting and Maintaining HFS+ Drives

To format and partition any drives as HFS+, connect the drives to a Mac computer and use the Apple OS X Disk Utility to format the drives as Mac OS Extended (Journaled).

Hard Disk Storage Space

Mono audio tracks recorded with 16-bit resolution at 44.1 kHz (CD quality) require approximately 5 MB of hard disk space per minute. The same tracks recorded with 24-bit resolution require about 7.5 MB per minute.

Stereo audio tracks recorded with 16-bit resolution at 44.1 kHz (CD quality) require approximately 10 MB of hard disk space per minute. The same tracks recorded with 24-bit resolution require about 15 MB per minute.

Table 6 lists the required disk space for certain track numbers and track lengths, to help you estimate your hard disk usage.

Table 6. Required hard drive space for audio tracks (44.1 kHz and 48 kHz sessions shown)

Number of Tracks and Length	16-bit at 44.1 kHz	16-bit at 48 kHz	24-bit at 44.1 kHz	24-bit at 48 kHz
1 mono track, 1 minute	5 MB	5.5 MB	7.5 MB	8.2 MB
1 stereo track (or two mono tracks), 5 minutes	50 MB	55 MB	75 MB	83 MB
1 stereo track (or two mono tracks), 60 minutes	600 MB	662 MB	900 MB	991 MB
24 mono tracks, 5 minutes	600 MB	662 MB	900 MB	991 MB
24 mono tracks, 60 minutes	7 GB	7.8 GB	10.5 GB	11.6 GB
32 mono tracks, 5 minutes	800 MB	883 MB	1.2 GB	1.3 GB
32 mono tracks, 60 minutes	9.4 GB	10.4 GB	14 GB	15.4 GB

Troubleshooting

Backing Up Your Work

It is highly recommended that you back up your work on a regular basis, and especially before making changes to your system configuration.

Backing Up Your Session Data

Back up your session and audio data frequently. There are a variety of media that are suited to back up projects of various sizes, from automated tape backup systems to high-capacity optical drives, or to CD burners.

The best way to back up an entire session is to use the Save Copy In command. This command lets you save the session file and all of its associated files to a new location.



You can also use the Auto Save Backup feature (in the Operation Preferences page) to have Pro Tools automatically save backups of the session file while you work.

Backing Up Your System Configuration

After configuring your system and Pro Tools, you should save an image of your system drive using a backup utility such as Norton Ghost (Windows) or Bombich Carbon Copy Cloner (Mac). By doing this, you can quickly restore your system configuration and settings if you encounter any problems.

Common Issues

Pro Tools Won't Launch

Problem

When you double-click the Pro Tools application or a Pro Tools session file, Pro Tools doesn't launch, or displays an error message.

Possible Solutions

- ◆ Check to be sure your computer has the required amount of RAM to launch Pro Tools. Visit www.avid.com/compatibility.
- ◆ Try a complete restart. Turn off your audio interfaces, computer peripherals and your computer, and then turn them on again in the proper sequence.

◆ If you tried to launch Pro Tools by double-clicking a Pro Tools session file, do the following:

- Close any error message.
- Double-click the Pro Tools application.
- In Pro Tools, choose File > Open Session to open the session.

◆ Reinstall the Pro Tools application, using the Pro Tools Installer disc.

Audio Interface Is Not Recognized

Problem

When you launch Pro Tools it does not recognize an audio interface, or a connected audio interface is not available.

Possible Solutions

- ◆ Turn off your computer and check to be sure your cables are properly and securely connected to your computer and to your audio interface.
- ◆ Verify that your Hardware Setup dialog settings are correct.

Performance Factors

There are several conditions that may adversely affect the performance of Pro Tools. These include:

Network Connections Close any network connections unless you are using them for network interchange of audio data.

Background Applications Any software utilities that run in the background or generate disk activity, such as virus protection, disk optimization, or file savers, should be turned off or removed.

Screen Savers Screen saver software should be completely disabled on your computer before running Pro Tools.

Power Saver Features Some automatic power saver features, such as those that spin down the system hard drive, can affect Pro Tools performance. These features should be turned off.

Before You Call Avid Support

Register Your System

Register your purchase by following the instructions on the Registration Information Card included with your system. By registering, you become eligible to receive the following:

- Technical support information
- Software update and upgrade notices
- Hardware warranty information

Gather Important Information

Avid wants to help you resolve problems as quickly and efficiently as possible. If you collect the following information before you contact Avid Support, it will make the diagnosis of your problem easier.

System Information

Computer

- Make, model, processor speed
- Amount of system RAM
- Operating system (version of Windows or Mac OS)
- Any Drivers, Disk Utilities, or other system-related applications you may have installed

Pro Tools Hardware

- Type of cards, interfaces, or peripherals

Hard Drives

- Make, Model
- Drive size (GB)
- Drive speed (RPM)
- Drive type (SCSI, FireWire, IDE/ATA)
- Utility used to format the drive
- Number and size of partitions on the drive

Pro Tools Software

- Pro Tools software version
- Plug-In versions
- Other Pro Tools software options or components
- Additional plug-ins from Avid Development Partners

Other Hardware

Refer to the manufacturer's documentation for operational details.

The most common hardware additions include:

- 1394 (FireWire) cards for Windows systems (manufacturer, model)
- Video Capture cards (manufacturer, model)

To verify that your hardware is qualified for use with your Pro Tools system, visit:

www.avid.com/compatibility

Other Software

If you are using other audio or video applications, refer to the manufacturer's documentation for operational details.

Make note of any other software that was running when a problem occurred.

Diagnostic Information

Note any DAE errors or other error codes you encounter. Additionally, note the ability to reproduce the problem under different conditions, for example, with another session, or after changing settings (such as the Hardware Buffer Size).

Resources

Whether you are new to Pro Tools or just starting out with your new system, we encourage you to read and utilize the many guides that Pro Tools provides. There are also useful online resources available, giving you everything from Pro Tools tips to Pro Tools answers.

About the Pro Tools Guides

In addition to any printed guides included with your system, PDF versions of the printed guides and many additional Pro Tools guides and Read Mes are installed automatically during Pro Tools installation (see “Documentation Installed Automatically with Pro Tools” on page 78). The PDFs are located in the Digidesign/Documentation folder on your local drive.

 *Printed copies of the Pro Tools Reference Guide and other guides in the Pro Tools guide set can be purchased separately from the Avid Store (<http://shop.avid.com>).*

User Guide

This *User Guide* for your system gives you detailed instructions for setting up and configuring software and hardware for optimum performance.

Printed Intro to Pro Tools Guide

The printed *Intro to Pro Tools* has tutorials on using Pro Tools (such as recording in a Pro Tools session, importing audio from a CD, and creating an audio CD from a Pro Tools session).

Guides Accessible in Pro Tools

The main Pro Tools guides are accessible from the Pro Tools Help menu. (Choose Help, then select a guide.)

These include:

- *Pro Tools Shortcuts*, provides a complete list of keyboard and Right-click shortcuts for Pro Tools.
- *Audio Plug-Ins Guide*, describes the audio plug-ins included with Pro Tools for both real-time and file-based audio processing as well as many other paid plug-in option offered from Avid.
- *Pro Tools Menus Guide*, covers all the Pro Tools on-screen menus.
- *Pro Tools Reference Guide*, explains Pro Tools software in extensive detail.

Documentation Installed Automatically with Pro Tools

When you install Pro Tools, you get useful PDF versions of many Pro Tools guides and Read Mes. This documentation can be found in the following locations:

Mac Applications/Digidesign/Documentation

Windows C:\Program Files\Digidesign\Documentation

 *To view or print PDF guides, you can use Adobe Reader (recommended) or Apple Preview (Mac only).*

Read Me Files

These contain late-breaking information and known issues pertaining to Pro Tools software and hardware configurations. Read Me files are installed in the Documentation folder when you install Pro Tools.

Helpful Online Resources

Once you get going, here are some helpful online resources:

- For questions about installation, visit Avid's online Knowledge Base. Go to:
<http://www.avid.com/onlinesupport>
- Get useful information, help, and tips from the worldwide community of Pro Tools users at the online User Conference. Go to:
<http://duc.avid.com>
- If you can't find your answer on the User Conference or the Knowledge Base, contact Avid email support. Go to:
<http://www.avid.com/support>

appendix h

Compliance Information

Environmental Compliance

Disposal of Waste Equipment by Users in the European Union



This symbol on the product or its packaging indicates that this product must not be disposed of with other waste. Instead, it is your responsibility to dispose of your waste equipment by handing it over to a designated collection point for the recycling of waste electrical and electronic equipment. The separate collection and recycling of your waste equipment at the time of disposal will help conserve natural resources and ensure that it is recycled in a manner that protects human health and the environment. For more information about where you can drop off your waste equipment for recycling, please contact your local city recycling office or the dealer from whom you purchased the product.

Proposition 65 Warning

⚠ *This product contains chemicals, including lead, known to the State of California to cause cancer and birth defects or other reproductive harm. Wash hands after handling.*

Perchlorate Notice

This product may contain a lithium coin battery. The State of California requires the following disclosure statement: "Perchlorate Material – special handling may apply, See www.dtsc.ca.gov/hazardouswaste/perchlorate."

Recycling Notice



EMC (Electromagnetic Compliance)

Avid declares that this product complies with the following standards regulating emissions and immunity:

- FCC Part 15 Class B
- EN 55022 Class B
- EN 55204 Class B
- AS/NZS 3548 Class B
- CISPR 22 Class B

FCC Compliance for United States

Radio and Television Interference

This equipment has been tested and found to comply with the limits for a Class B digital device, pursuant to Part 15 of the FCC Rules.

DECLARATION OF CONFORMITY

We, Avid, 2001 Junipero Serra Boulevard
Daly City, CA 94014-3886, USA
650-731-6300

declare under our sole responsibility that the product Mbox

complies with Part 15 of FCC Rules.

Operation is subject to the following two conditions:

- (1) this device may not cause harmful interference, and
- (2) this device must accept any interference received, including interference that may cause undesired operation.

Communication Statement

NOTE: This equipment has been tested and found to comply with the limits for a Class B digital device, pursuant to Part 15 of the FCC Rules. These limits are designed to provide reasonable protection against harmful interference in a residential installation. This equipment generates, uses, and can radiate radio frequency energy and, if not installed and used in accordance with the instructions, may cause harmful interference to radio communications. However, there is no guarantee that interference will not occur in a particular installation. If this equipment does cause harmful interference to radio or television reception, which can be determined by turning the equipment off and on, the user is encouraged to try and correct the interference by one or more of the following measures:

- Reorient or locate the receiving antenna.
- Increase the separation between the equipment and receiver.
- Connect the equipment into an outlet on a circuit different from that to which the receiver is connected.
- Consult the dealer or an experienced radio/TV technician for help.

Any modifications to the unit, unless expressly approved by Avid, could void the user's authority to operate the equipment.

Australian Compliance



Canadian Compliance

This Class B digital apparatus complies with Canadian ICES-003

Cet appareil numérique de la classe A est conforme à la norme NMB-003 du Canada

CE Compliance

(EMC and Safety)



Avid is authorized to apply the CE (Conformité Européenne) mark on this compliant equipment thereby declaring conformity to EMC Directive 89/336/EEC and Low Voltage Directive 73/23/EEC.

Safety Compliance

Warning



Important Safety Instructions

- 1) Read these instructions.
- 2) Keep these instructions.
- 3) Heed all warnings.
- 4) Follow all instructions.
- 5) Do not use this equipment near water.
- 6) Clean only with dry cloth.
- 7) Do not block any ventilation openings. Install in accordance with the manufacturer's instructions.
- 8) Do not install near any heat sources such as radiators, heat registers, stoves, or other equipment (including amplifiers) that produce heat.
- 9) Do not defeat the safety purpose of the polarized or grounding-type plug. A polarized plug has two blades with one wider than the other. A grounding type plug has two blades and a third grounding prong. The wide blade or the third prong are provided for your safety. If the provided plug does not fit into your outlet, consult an electrician for replacement of the obsolete outlet.
- 10) Protect power cords from being walked on or pinched particularly at plugs, convenience receptacles, and the point where they exit from the equipment.
- 11) Only use attachments/accessories specified by the manufacturer.
- 12) For products that are not rack-mountable: Use only with a cart, stand, tripod, bracket, or table specified by the manufacturer, or sold with the equipment. When a cart is used, use caution when moving the cart/equipment combination to avoid injury from tip-over.
- 13) Unplug this equipment during lightning storms or when unused for long periods of time.
- 14) Refer all servicing to qualified service personnel. Servicing is required when the equipment has been damaged in any way, such as power-supply cord or plug is damaged, liquid has been spilled or objects have fallen into the equipment, the equipment has been exposed to rain or moisture, does not operate normally, or has been dropped.
- 15) For products that are a Mains powered device:
The equipment shall not be exposed to dripping or splashing and no objects filled with liquids (such as vases) shall be placed on the equipment.
Warning! To reduce the risk of fire or electric shock, do not expose this equipment to rain or moisture.
- 16) For products containing a lithium battery:
CAUTION! Danger of explosion if battery is incorrectly replaced. Replace only with the same or equivalent type.
- 17) The equipment shall be used at a maximum ambient temperature of 40° C.

index

A

- audio
 - digital connections 41
- Audio MIDI Setup (AMS) (Macintosh) 59
- authorizing Pro Tools LE
 - Mac 7
 - Windows 14

C

- Cache Size 22
- Clean Uninstall (Mac) 9
- Clock Source 24
 - Internal setting 24
 - S/PDIF (digital) setting 24
- CPU Usage Limit 19, 20

D

- DAE Playback Buffer Size 21
- DMA option (Windows), enabling 27
- drive formatting
 - Mac 68
 - Windows 69
- drive maintenance 67
- drive requirements 3

E

- Energy Saver (Mac), turning off 25

F

- FireWire requirements 68

G

- gain
 - headphones 32
 - input 31

H

- hard drives
 - drive formats 67
 - FireWire requirements 68
 - formatting 68, 69
 - formatting (Mac) 68
 - IDE/ATA requirements 68
 - maintenance 67, 70
 - optimizing 70
 - partitioning 69
 - requirements 3
 - SCSI requirements 68
 - space requirements 72
- Hardware Buffer Size 18
- headphones
 - gain control 32
 - output 32, 33

I

- I/O Setup
 - Windows 24
- IDE/ATA requirements 68
- Ignore Errors During Playback/Record option 20
- indicators
 - peak level 31, 32
 - phantom power 32
 - USB connection 33
- input and output connectors 34
- inputs
 - analog 35
 - digital 34
 - gain 31
 - monitoring 33
- installing Pro Tools LE
 - Mac 5
 - Windows 11
- installing QuickTime (Windows) 13

J

journaling (Mac), enabling 27

L

latency

Hardware Buffer Size 18

M

Mbox

features 1

MIDI

connections 42

requirements 2

setup (Macintosh) 59

setup (Windows) 63

MIDI Studio Setup (MSS) (Windows) 63

Minimize Additional I/O Latency option 21

mono switch 33

N

network cards (Windows), disabling 29

network connections 74

O

optimizing hard drives 70

outputs

Monitor outputs 34

P

partitioning hard drives 69

Patch Select dialog

Macintosh 62

Windows 66

peak indicators 31, 32

phantom power 39

indicator 32

when to use 32, 39

Plug-In Streaming Buffer 23

Plug-In Streaming Buffer Size 22

plug-ins

multiprocessors 19

Pro Tools

demo session (Windows) 9, 15

removing (Windows) 9, 15

Pro Tools LE

capabilities 2

configuration (Windows) 18

installing (Mac) 5

installing (Windows) 11

Processor Scheduling performance (Windows) 30

Q

QuickTime

installing (Windows) 13

R

recording

digital inputs 41

removing Pro Tools

Windows 9, 15

RTAS Processors setting 19

S

S/PDIF 34

Safe Uninstall (Mac) 9

Sample Rate 23

screen savers 74

SCSI requirements 68

Software Update (Mac), turning off 25

sources

analog 35

DI 35

digital 34

line 35

microphone 35

selecting 32

Spotlight indexing (Mac), disabling 26

Startup items (Windows), disabling 30

Stereo Width control 41, 42

system

optional optimizations (Windows) 29

recommended optimizations (Windows) 29

required optimizations (Windows) 27

shutting down 17

starting up 17

system optimization

Mac 25

Windows 29

system settings

Cache Size 22

Clock Source 24

CPU Usage Limit 20

Hardware Buffer Size 18

I/O Setup 24

Plug-In Streaming Buffer 23

Plug-In Streaming Buffer Size 22

Sample Rate 23

T

technical support 4

TRS 38

U

uninstalling Pro Tools

Mac 9

Windows 15

USB connection indicator 33

User Account Control (UAC)

disabling 28

W

website 78



Avid
2001 Junipero Serra Boulevard
Daly City, CA 94014-3886 USA

Technical Support (USA)
Visit the Online Support Center at
www.avid.com/support

Product Information
For company and product information,
visit us on the web at www.avid.com