

Series 45 Frame F  
Open Circuit Axial  
Piston Pumps

Service Manual

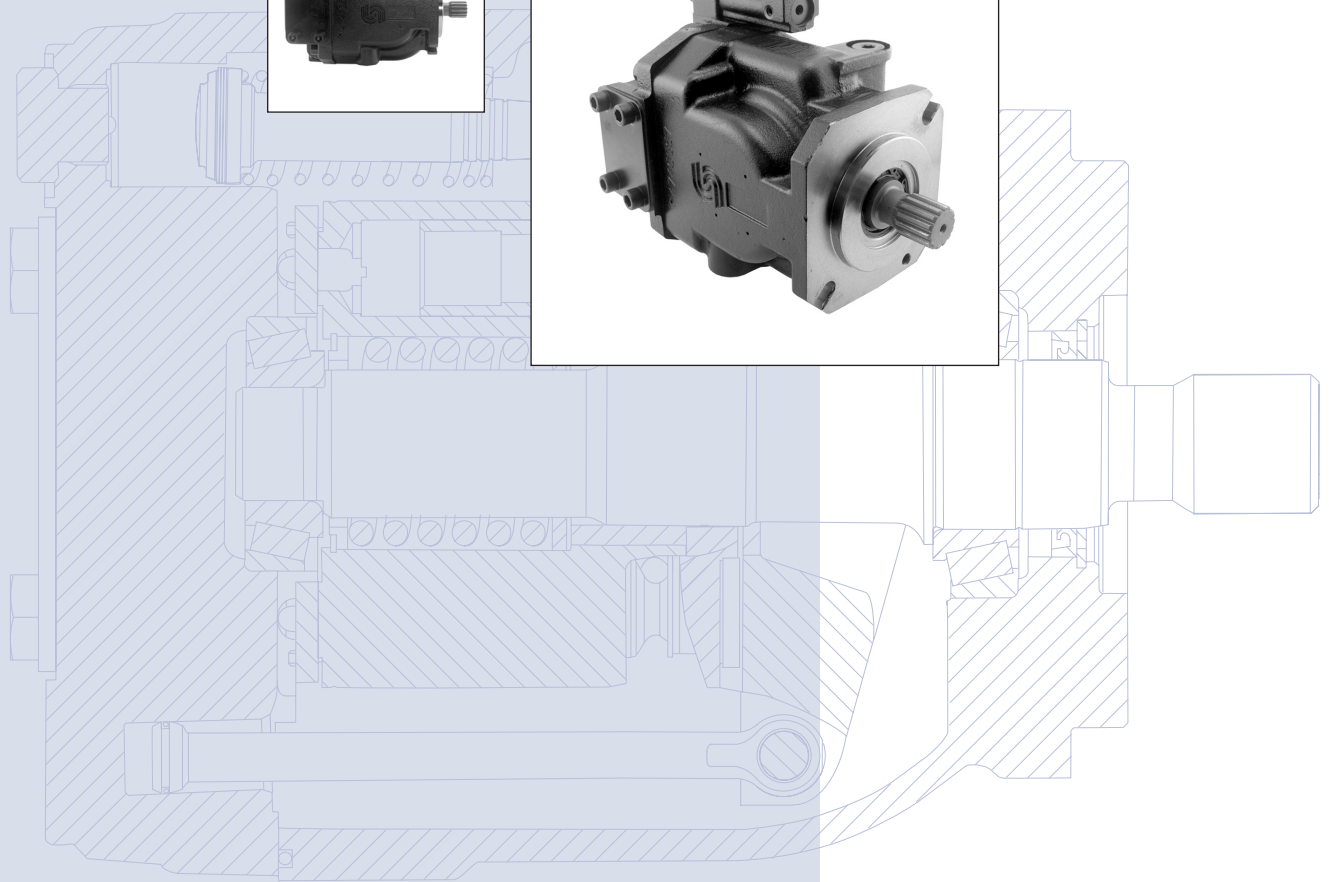

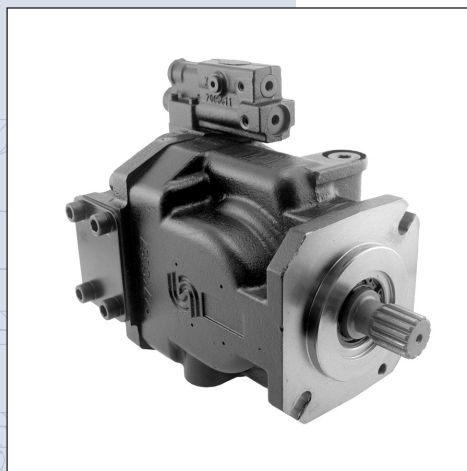

## HISTORY OF REVISIONS

### *Table of Revisions*

Date	Page	Changed	Rev.
October 2012	various	add electric controls	AF
November 2010	last	new back page	AE
February 2010	last	Fix Osaka address	AD
July 2009	21	Add Pressure change - PC adjustment specs	AC
September 2007			AB
November 2006	-	First edition	AA

© 2012 Sauer-Danfoss. All rights reserved.

Sauer-Danfoss accepts no responsibility for possible errors in catalogs, brochures and other printed material. Sauer-Danfoss reserves the right to alter its products without prior notice. This also applies to products already ordered provided that such alterations aren't in conflict with agreed specifications. All trademarks in this material are properties of their respective owners. Sauer-Danfoss and the Sauer-Danfoss logotype are trademarks of the Sauer-Danfoss Group.



**INTRODUCTION**

Overview .....5  
 Safety precautions .....5  
     Unintended machine movement .....5  
     Flammable cleaning solvents.....5  
     Fluid under pressure.....5  
     Personal safety .....5  
 Warranty .....6  
 Symbols used in Sauer-Danfoss literature.....6  
 General description .....7  
 System circuit.....8

**TECHNICAL SPECIFICATIONS**

General specifications .....9  
     Type of mounting .....9  
     Auxiliary mounting pad options .....9  
     Control options.....9  
     Port options .....9  
     Direction of rotation .....9  
     Installation position .....9  
     Technical specifications.....9  
 Hydraulic parameters.....10  
     Inlet pressure.....10  
     Pressure compensator valve setting .....10  
     Case pressure .....10  
     Hydraulic fluid .....10  
     Temperature range.....11  
     Fluid viscosity .....11  
     Filtration .....11

**FEATURES**

Displacement limiter.....12  
 Auxiliary mounting pads .....12  
 Input shafts.....12  
 Control options .....13  
     PC control .....13  
     LS control .....14  
     Electric Proportional Controls .....15  
     Electric On/Off Controls.....15

**PRESSURE MEASUREMENT**

Required tools .....16  
 Port locations and gauge installation .....16

**INITIAL START-UP PROCEDURES**

General.....17  
 Start-up procedure .....17

**FLUID AND FILTER MAINTENANCE**

Recommendations.....18



<b>TROUBLESHOOTING</b>	Excessive noise and / or vibration .....	19
	Actuator response is sluggish .....	19
	System operating hot .....	20
	Low pump output flow .....	20
	Pressure or flow instability .....	20
	System pressure not reaching PC setting .....	21
	High inlet vacuum .....	21
<b>ADJUSTMENTS</b>	PC control .....	22
	LS control .....	23
<b>MINOR REPAIR</b>	Shaft seal replacement .....	24
	Auxiliary pads .....	25
	LS and PC Controls .....	26
	Electric Controls .....	28
	Servo Control Orifice .....	30
	Plug and fitting sizes and torques .....	31



## OVERVIEW

This manual includes information for the installation, maintenance, and minor repair of the Series 45 Frame F open circuit axial piston pumps. The manual includes a description of the units and their individual components, troubleshooting information, and minor repair procedures. Performing installation, maintenance, and minor repair of Series 45 Frame F axial piston pumps according to the procedures in this manual will not affect your warranty.

Performing minor repairs requires the unit to be removed from the vehicle/machine. Thoroughly clean the unit before beginning maintenance, or repair activities. Since dirt and contamination are the greatest enemies of any type of hydraulic equipment, follow cleanliness requirements strictly. This is especially important when changing the system filter and when removing hoses or plumbing.

A worldwide Global Service Partner Network is available for major repairs. Major repairs require the removal of the unit's endcap, which voids the warranty unless done by a Global Service Partner. Sauer-Danfoss Global Service Partners are trained by the factory and certified on a regular basis. You can locate your nearest Global Service Partner using the distributor locator at [www.sauer-danfoss.com](http://www.sauer-danfoss.com)

## SAFETY PRECAUTIONS

Always consider safety precautions before beginning a service procedure. Protect yourself and others from injury. Take these general precautions whenever servicing a hydraulic system.

### Unintended machine movement

#### Warning

---

Unintended movement of the machine or mechanism may cause injury to the technician or bystanders. To protect against unintended movement, secure the machine or disable / disconnect the mechanism while servicing.

---

### Flammable cleaning solvents

#### Warning

---

Some cleaning solvents are flammable. To avoid possible fire, do not use cleaning solvents in an area where a source of ignition may be present.

---

### Fluid under pressure

#### Warning

---

Escaping hydraulic fluid under pressure can have sufficient force to penetrate your skin causing serious injury and/or infection. This fluid may also be hot enough to cause burns. Use caution when dealing with hydraulic fluid under pressure. Relieve pressure in the system before removing hoses, fittings, gauges, or components. Never use your hand or any other body part to check for leaks in a pressurized line. Seek medical attention immediately if you are cut by hydraulic fluid.

---

### Personal safety

#### Warning

---

Protect yourself from injury. Use proper safety equipment, including safety glasses, at all times.

---





























## WARRANTY

Performing installation, maintenance, and minor repairs according to the procedures in this manual will not affect your warranty. Major repairs requiring the removal of a unit's endcap voids the warranty unless done by a Sauer-Danfoss Global Service Partner.

## SYMBOLS USED IN SAUER-DANFOSS LITERATURE

These symbols are in the illustrations and text of this manual. They communicate helpful information at the point where it is most useful to the reader.

In most instances, the appearance of the symbol itself denotes its meaning. The legend below defines the symbol and explains its purpose.

	WARNING may result in injury		Tip, helpful suggestion
	CAUTION may result in damage to product or property		Lubricate with hydraulic fluid
	Reusable part		Apply grease / petroleum jelly
	Non-reusable part, use a new part		Apply locking compound
	Non-removable item		Inspect for wear or damage
	Option – either part may exist		Clean area or part
	Superseded – parts are not interchangeable		Be careful not to scratch or damage
	Measurement required		Note correct orientation
	Flatness specification		Mark orientation for reinstallation
	Parallelism specification		Torque specification
	External hex head		Press in – press fit
	Internal hex head		Pull out with tool – press fit
	Torx head		Cover splines with installation sleeve
	O-ring boss port		Pressure measurement / gauge location or specification

## GENERAL DESCRIPTION

Sauer-Danfoss Series 45 Frame F open circuit piston pumps convert input torque into hydraulic power. The input shaft transmits rotational force from the prime mover to the cylinder block. Tapered roller bearings support the shaft at the front and rear of the pump. The cylinder block connects to the input shaft through splines on the shaft. A lip-seal at the front end of the pump prevents leakage where the shaft exits the pump housing. The spinning cylinder block contains nine reciprocating pistons. Each piston has a brass slipper connected at one end by a ball joint. The slippers are held to the swashplate by the spring retainer and block spring. The block spring also holds the cylinder block to the valve plate. The reciprocating movement of the pistons occurs as the slippers slide against the inclined swashplate during rotation. The valve plate connects one half of the cylinder block to pump inlet and the other half to pump outlet. As each piston cycles in and out of its bore, fluid is drawn from the inlet and displaced to the outlet thereby imparting power into the system circuit. A small amount of fluid leaks from the cylinder block / valve plate and slipper / swashplate interfaces for lubrication and cooling. Case drain ports return this fluid to the reservoir.

The angle of the swashplate controls the volume of fluid displaced into the system circuit. The bias piston forces the swashplate into an inclined position (into stroke). The servo piston opposes the action of the bias piston and spring, forcing the swashplate out of stroke when hydraulic pressure in the control circuit rises above the spring force.

The pump control, by varying the pressure at the servo piston, controls the displacement of fluid in the system circuit. Controls designed for **Pressure Compensation (PC)** or **Load Sensing (LS)** are available. For a detailed description of control operation, refer to *Control options, operation*, page 13.

### *Pump and control sectional view*

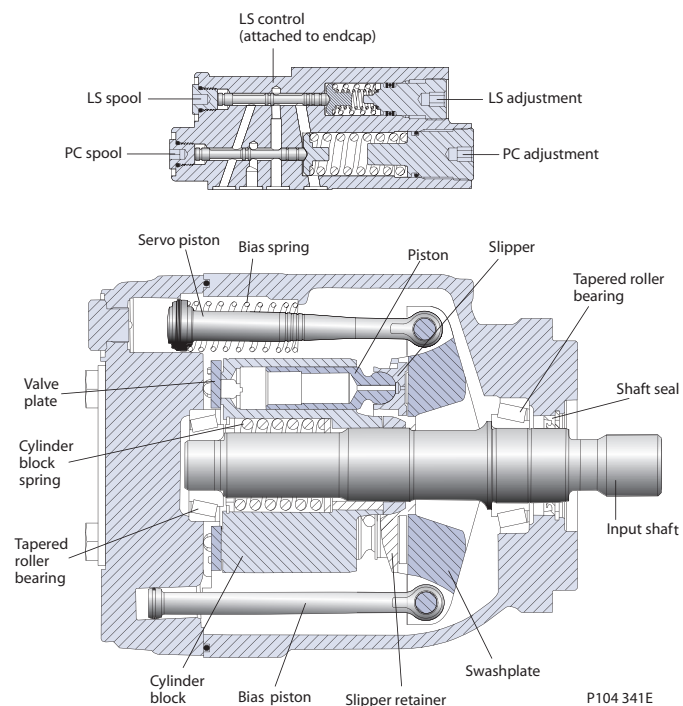

**SYSTEM CIRCUIT**

The pump receives fluid directly from the reservoir through the inlet line. A screen in the inlet line protects the pump from large contaminants. The pump outlet feeds a PVG-32 multi-section, load sensing, directional control valve. The PVG valve directs pump flow to the cylinder and gear motor. A heat exchanger cools the fluid returning from the valve. A filter cleans the fluid before it returns to the reservoir.

Flow in the circuit determines the speed of the actuators. The position of the PVG valve determines the flow demand. A hydraulic pressure signal (LS signal) communicates demand to the pump control. The pump control monitors the pressure differential between pump outlet and the LS signal, and regulates servo pressure to control the swashplate angle. Swashplate angle determines pump flow.

Actuator load determines system pressure. The pump control monitors system pressure and will decrease the swashplate angle to reduce flow if system pressure reaches the PC setting. A system relief valve in the PVG valve acts as a back-up to control system pressure.

*Pictorial circuit diagram*

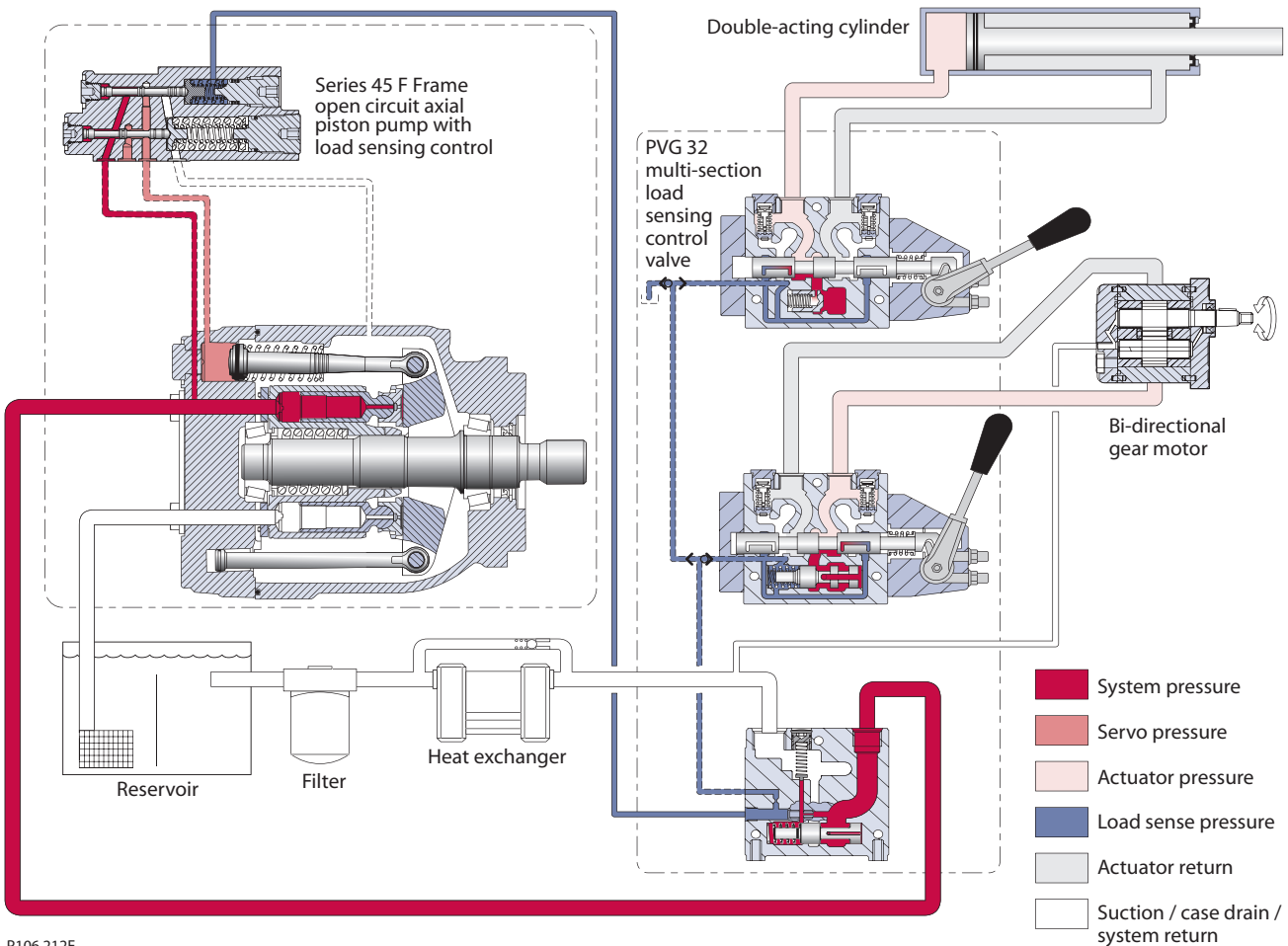

P106 212E

<sup>1</sup> Full available flow is a function of pump displacement, operating speed, and efficiency. Refer to *Series 45 Frame F Axial Piston Open Circuit Pumps Technical Information, 520L0948* for details.





**GENERAL  
SPECIFICATIONS**

**Type of mounting**

SAE-C mounting flange.

**Auxiliary mounting pad options**

SAE-A, SAE-B, SAE-B-B, SAE-C, SAE C-C

**Control options**

PC: Pressure Compensator

LS: Load Sensing (with PC)

**Port options**

Inlet and system ports: SAE flanged ports, code 61 Inlet Code 62 outlet.  
Axial (end) ports or radial (side) ports.

All other ports: SAE straight thread O-ring boss.

**Direction of rotation**

Clockwise or counterclockwise.

**Installation position**

Installation position is discretionary. To satisfy inlet pressure conditions, we recommend you locate the pump below the lowest level of hydraulic fluid in the reservoir. The housing must always be filled with hydraulic fluid.

**Technical specifications**

*Features and options*

Feature		Unit	Model	
			F74B	F90C
Maximum displacement		cm <sup>3</sup> [in <sup>3</sup> ]	74 [4.52]	90 [5.49]
Flow at rated speed (theoretical)		l/min [US gal/min]	177.6 [46.9]	198 [52.3]
Input torque at maximum displacement (theoretical)		N•m/bar [lbf•in/1000 psi]	1.178 [719]	1.432 [874]
Mass moment of inertia of internal rotating components		kg•m <sup>2</sup> [slug•ft <sup>2</sup> ]	0.00630 [0.00465]	0.00650 [0.00480]
Weight	Axial ports	kg [lb]	29 [63]	
	Radial ports		31.8 [70.1]	
Rotation			Clockwise, Counterclockwise	
Mounting			SAE B 2 blot, SAE-C 4 bolt	
Auxiliary mounting			SAE-A, SAE-B, SAE-BB, SAE-C	
System ports (type)			4-bolt split flange	
System ports (location)			Axial, Radial	
Control types			PC, Remote PC, LS, Electric	
Shafts	Splined		14 tooth, 17 tooth	
	Straight		Ø 31.75 mm [1.25 in]	
Displacement limiters			Optional, adjustable	



**GENERAL SPECIFICATIONS (continued)**

Ratings			Model	
			G74B	G90C
Input speed <sup>1</sup>	minimum	min <sup>-1</sup> (rpm)	500	500
	continuous		2400	2200
	maximum		2800	2600
Working pressure	continuous	bar [psi]	310 [4495]	260 [3770]
	maximum		400 [5800]	350 [5075]
External shaft loads	External moment (M <sub>e</sub> )	N•m [lbf•in]	300 [2655]	
	Thrust in (T <sub>in</sub> ), out (T <sub>out</sub> )	N [lbf]	2900 [650]	
Bearing life	at 140 bar [2030 psi]	B <sub>10</sub> hours	31 300	17 400
	at 210 bar [3045 psi]		1110	5700
	at 260 bar [3770 psi]		4810	2490
	at 310 bar [4495 psi]		3080	1636
Mounting flange load moments	Vibratory (continuous)	N•m [lbf•in]	3730 [33 000]	
	Shock (maximum)		13 220 [117 000]	

1. Input speeds are valid at 1 bar absolute [0 in Hg vac] inlet pressure. See *Inlet pressure vs. speed* charts.

**HYDRAULIC PARAMETERS**

**Inlet pressure**

Minimum pressure, continuous = 0.8 bar absolute [6.7 inch Hg vacuum]  
(at reduced maximum pump speed)

Minimum pressure, cold start = 0.5 bar absolute [15.1 inch Hg vacuum]

**Pressure compensator valve setting**

*PC control setting range*

Model	bar	psi
F74B	100–310	1450–4495
F90C	100–260	1450–3770

**Case pressure**

Maximum continuous: 0.5 bar [7 psi] above inlet  
Intermittent: 2 bar [29 psi] cold start

**Hydraulic fluid**

Refer to Sauer-Danfoss publication: *Fluids and Filtration* **520L0463**. For information on biodegradable fluids refer to *Biodegradable Hydraulic Fluids*, **520L0465**. See *Fluid and filter maintenance*, page 17 for recommended fluid and filter change intervals.

**HYDRAULIC  
PARAMETERS  
(continued)**

**Temperature range**

*Temperature limits*

<b>Minimum (intermittent, cold start)</b>	- 40° C [- 40° F]
<b>Continuous<sup>1</sup></b>	82° C [180° F]
<b>Maximum<sup>2</sup></b>	104° C [220° F]

**Fluid viscosity**

*Fluid viscosity limits*

<b>Condition</b>		<b>mm<sup>2</sup>/s (cSt)</b>	<b>SUS</b>
v min.	continuous	9	58
	intermittent	6.4	47
v max.	continuous	110	500
	intermittent (cold start)	1000	4700

**Filtration**

Required cleanliness level: ISO 4406 Class 18/13 or better. Refer to Sauer-Danfoss publications *Fluids and Filtration 520L0463* and *Design Guidelines for Selecting and Maintaining the Required Hydraulic Fluid Cleanliness 520L0465*. See *Fluid and filter maintenance*, page 18 for recommended fluid and filter change intervals.

<sup>1</sup> Hydraulic fluid viscosity must be maintained within the prescribed limits.

<sup>2</sup> As measured at the hottest point in the system, e.g. drain line.



### DISPLACEMENT LIMITER

Frame F Series 45 pumps are available with an optional adjustable maximum displacement limiter. The adjustable stop limits the pump's maximum displacement. The displacement change per turn is 6.8 cm<sup>3</sup>/turn [0.47 in<sup>3</sup>/turn] for the F90C and 6.0 cm<sup>3</sup>/turn [6.1 in<sup>3</sup>/turn] for the F74B

#### Displacement limiter

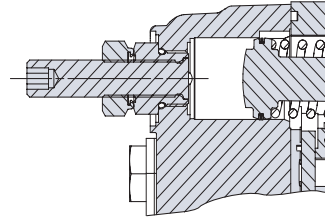

P104 345

### AUXILIARY MOUNTING PADS

Auxiliary mounting pads are available for all radial ported Series 45 pumps. These pads are typically used for mounting auxiliary hydraulic pumps.

Since the auxiliary pad operates under case pressure, you must use an O-ring to seal the auxiliary pump mounting flange to the pad. Oil from the main pump case lubricates the drive coupling. For details refer to *Series 45 F Frame Axial Piston Open Circuit Pumps Technical Information 520L0948*.

#### Auxiliary pad options

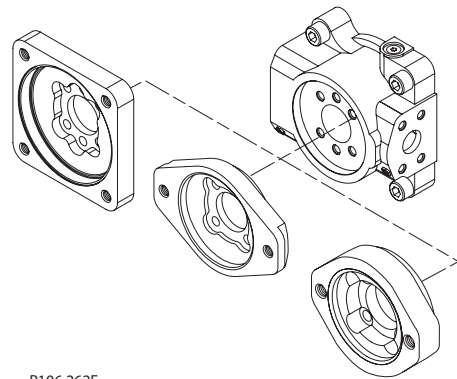

P106 262E

### INPUT SHAFTS

Series 45 F Frame pumps are available with a variety of splined and straight keyed shafts. For information on shafts refer to *Series 45 F Frame Axial Piston Open Circuit Pumps Technical Information 520L0948*.

## CONTROL OPTIONS

The Series 45 Frame F pumps have two control options, a **Load Sensing (LS)** control with **Pressure Compensator (PC)** or a **PC only** control.

### Operation

#### General

The bias piston and spring (1&2) acts at all times to push the swashplate (4) to maximum angle causing the pump to stroke. The servo piston (3) acts against the bias piston and spring to reduce the swashplate angle causing the pump to destroke. Swashplate angle determines pump outlet flow. The pump control, depending on conditions in the system circuit, sets swashplate angle by metering system pressure to the servo piston.

*Cross-section pump*

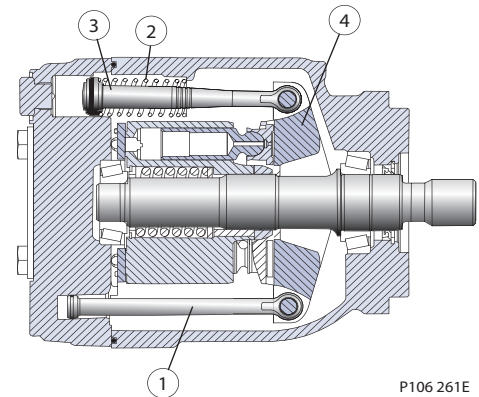

P106 261E

**Bias spring and servo piston set swashplate position**

### PC control

The PC control design maintains a constant pressure in the hydraulic circuit as flow varies. The PC control modulates pump flow accordingly to maintain system pressure at the PC setting as the PC adjusting plug (4) and spring (5) define.

*Cross-section PC control*

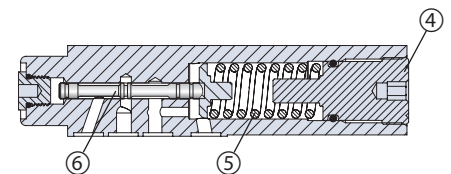

P104 049

**PC spool shifts to port system pressure to servo piston**

When system pressure, acting on the non-spring end of the PC spool (6), overcomes the force of the PC spring (5), the spool shifts porting system pressure to the servo piston and the swashplate angle decreases. When system pressure drops below the PC setting, the PC spring shifts the spool in the opposite direction connecting the servo piston to pump case and the swashplate angle increases. The swashplate is maintained at whatever angle is required to keep system pressure at the PC setting.



**Control options  
(continued)**

**LS control**

The LS control design matches pump flow with system demand. The LS control senses the flow demand of the system as a pressure drop across the **External Control Valve (ECV)**. As the ECV opens and closes, the pressure delta across the valve changes. When opening, the delta decreases. When closing, the delta increases. The LS control then increases or decreases pump flow to the system until the pressure delta becomes equal to the LS setting as defined by the LS adjusting plug (7) and spring (8).

*Cross-section LS control*

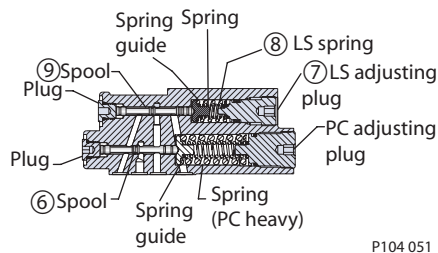

**LS spool shifts to port system pressure to servo piston**

to the spring end. This arrangement allows the LS spool to act on the delta between system pressure and LS pressure. The LS spring sets the threshold of operation (LS setting).

Because the swashplate is biased to maximum angle, the pump attempts to deliver full flow to the hydraulic system. When the flow being delivered exceeds demand, the pressure delta across the ECV is great enough to overcome spring force and shift the LS spool porting system pressure to the servo piston. The pump de-strokes reducing flow until the delta across the ECV becomes equal to the LS setting. When flow being delivered is less than demand, the delta across the ECV drops below the LS setting and the LS spring shifts the spool connecting the servo piston to pump case. The pump strokes increasing flow until the delta across the ECV becomes equal to the LS setting.

When the external control valve is placed in neutral, it connects the LS signal line to drain. With no LS pressure acting on the non-spring end of the LS spool, the pump adjusts stroke to whatever position necessary to maintain system pressure at the LS setting. The pump is now in standby mode.

Because of the series arrangement of the LS and PC spools, the PC spool will override the LS spool. If at any time system pressure reaches the PC setting, the PC spool will shift blocking the passage that connects the LS spool with the servo piston, thus porting system pressure to the servo piston causing the pump to destroke.

*Typical load-sensing control valve*

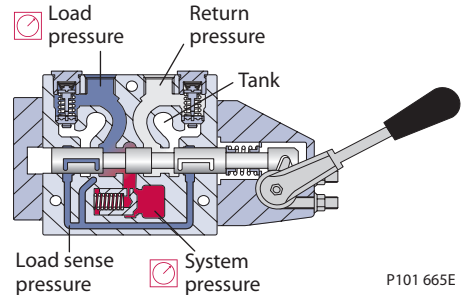

**Pressure drop across external control valve defines system demand**

The LS control consists of two spool valves that connect the servo piston either to pump case or system pressure. The PC spool (6) controls the pressure-compensating function of the control as previously described. The LS spool (9) controls the load-sensing function. The PC spool has priority over the LS spool.

Through internal porting, system pressure (upstream of ECV) is applied to the non-spring end of the LS spool, and through hydraulic line connected at port X, LS pressure (downstream of ECV) is applied

**CONTROL OPTIONS  
(CONTINUED)**

**Electric Proportional Controls**

**PLUS+1 Compliance**

All Series 45 Electric controls have met and passed the Sauer-Danfoss PLUS+1 compliance standard testing, and as such, this Series 45 control is PLUS+1 compliant. PLUS+1 compliance blocks are available on the Sauer-Danfoss website, within the PLUS+1 Guide section.



COMPLIANT

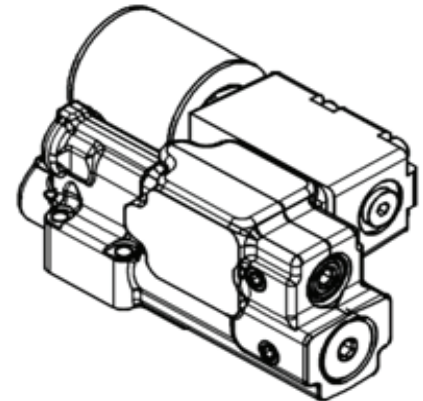

**Electric Proportional Control Principle**

The Electric Proportional Control consists of a proportional solenoid integrated into a Remote Pressure Compensated control. This control allows the pump to be operated at any pressure limit between the Load Sense and Pressure Compensation settings by varying the current sent to the solenoid.

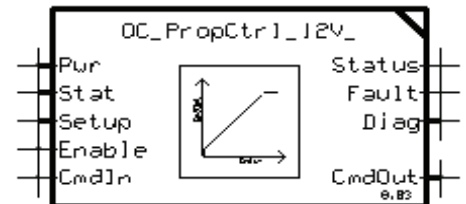

**Electric On/Off Controls**

**PLUS+1 Compliance**

All Series 45 Electric controls have met and passed the Sauer-Danfoss PLUS+1 compliance standard testing, and as such, this Series 45 control is PLUS+1 compliant. PLUS+1 compliance blocks are available on the Sauer-Danfoss website, within the PLUS+1 Guide section.



COMPLIANT

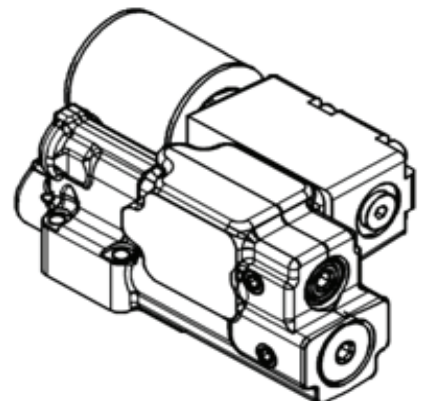

**Electric On-Off Control Principle**

The Electric On/Off Control consists of an On/Off solenoid integrated into a Remote Pressure Compensated control. This control allows the pump to be operated at either the Load Sense pressure setting when "On", or the Pressure Compensation pressure setting when "Off".

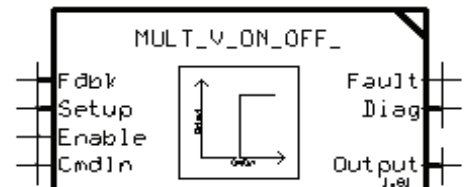

**REQUIRED TOOLS**

The service procedures described in this manual can be performed using common mechanic's hand tools. Special tools, if required are shown. Calibrate pressure gauges frequently to ensure accuracy. Use snubbers to protect gauges.

**PORT LOCATIONS AND GAUGE INSTALLATION**

The illustration below shows gauge port locations. Recommended pressure gauges and fittings are in the table.

*Gauge and port information*

Port	Purpose	Range of gauge	Fitting
M2	System pressure	0-300 bar [0-5000 psi]	9/16 - 18 O-ring fitting
M4	Servo pressure	0-300 bar [0-5000 psi]	9/16 - 18 O-ring fitting
L1, L2	Case pressure	0-10 bar [0-100 psi]	7/8 - 14 O-ring fitting
X1	LS signal	0-300 bar [0-5000 psi]	7/16 - 20 O-ring fitting (tee into LS signal line)

*Gauge port locations*

**Legend**

- B = Main pressure line
- S = Suction line
- L1, L2 = Case drain lines
- X = Load sensing pressure port
- M2 = Gauge port for port B
- M4 = Gauge port — servo pressure

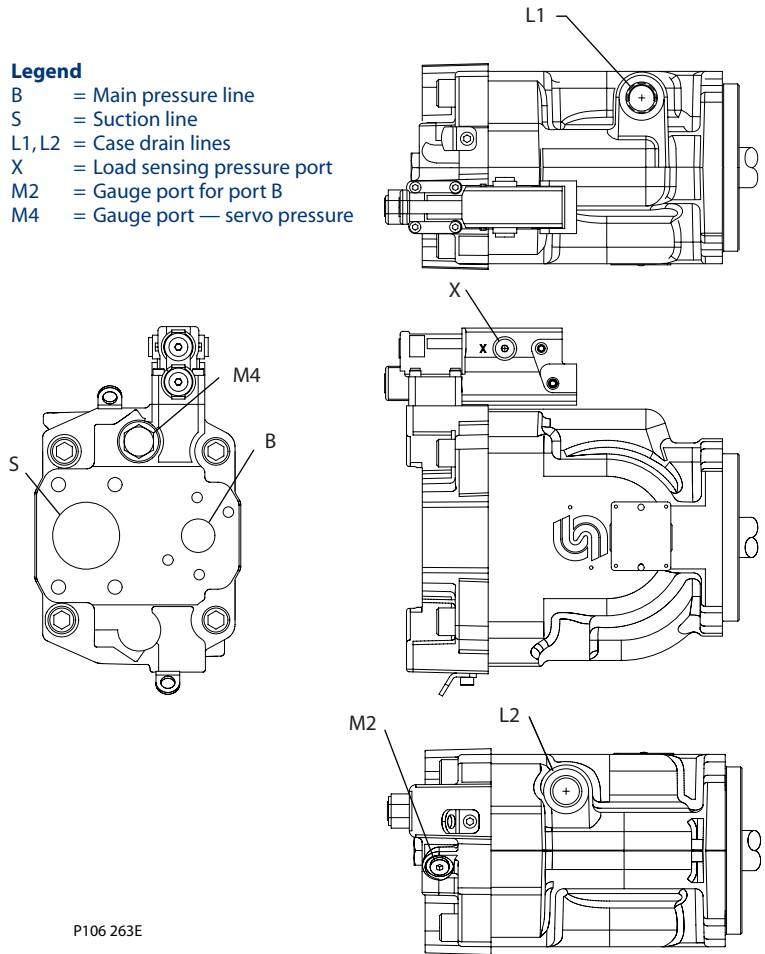

P106 263E





## GENERAL

Follow this procedure when starting-up a new Series 45 installation or when restarting an installation in which the pump has been removed.

### Warning

Unintended movement of the machine or mechanism may cause injury to the technician or bystanders. To protect against unintended movement, secure the machine or disable/disconnect the mechanism while servicing.

Prior to installing the pump, inspect for damage incurred during shipping. Make certain all system components (reservoir, hoses, valves, fittings, heat exchanger, etc.) are clean prior to filling with fluid.

## START-UP PROCEDURE

### CAUTION

Incorrect shaft alignment may result in damage to drive shaft, bearings, or seal which can cause external oil leakage.

1. Connect the pump to the prime mover. Ensure that pump shaft is properly aligned with the shaft of the prime mover. 
2. Fill the main pump housing with clean filtered hydraulic fluid. Pour filtered oil directly into the upper most case drain port.
3. To ensure the pump stays filled with oil, install the case drain line in the upper most case drain port.
4. Fill the inlet line leading from the pump to the reservoir. Check the inlet line for properly tightened fittings. Be certain it is free of restrictions and air leaks.
5. Fill the reservoir with recommended hydraulic fluid. Always filter fluid through a 10 micron filter pouring into the reservoir. Never reuse hydraulic fluid.
6. Install a gauge at port or M2 to monitor system pressure during start up.

---

Follow recommendations in the vehicle / machine operator's manual for prime mover start up procedures.

---

7. While watching the pressure gauge installed at M2, jog the prime mover or run at the lowest possible speed until system pressure builds to normal levels (minimum 11 bar [160 psi]). Once system pressure is established, increase to full operating speed. If system pressure is not maintained, shut down the prime mover, determine cause, and take corrective action. Refer to *Troubleshooting*, page 19.
8. Operate the hydraulic system for at least fifteen minutes under light load conditions.
9. Check and adjust control settings as necessary after installation. Refer to *Adjustments*, page 22.
10. Shut down the prime mover and remove the pressure gauge. Replace plug at port M2.
11. Check the fluid level in the reservoir; add clean filtered fluid if necessary.

The pump is now ready for operation.



## RECOMMENDATIONS

To ensure optimum life of Series 45 products, perform regular maintenance of the fluid and filter. Contaminated fluid is the main cause of unit failure. Take care to maintain fluid cleanliness when servicing.

Check the reservoir daily for proper fluid level, the presence of water, and rancid fluid odor. Water in the fluid may be noted by a cloudy or milky appearance or free water in the bottom of the reservoir. Rancid odor indicates the fluid has been exposed to excessive heat. Change the fluid immediately if these conditions occur. Correct the problem immediately.

Change the fluid and filter per the vehicle / machine manufacturer's recommendations or at these intervals:

### *Fluid and filter change interval*

Reservoir type	Maximum change interval
Sealed	2000 hours
Breather	500 hours

Change the fluid more frequently if it becomes contaminated with foreign matter (dirt, water, grease, etc.) or if the fluid is subjected to temperature levels greater than the recommended maximum.

---

Dispose of used hydraulic fluid properly. Never reuse hydraulic fluid.

---

Change filters whenever the fluid is changed or when the filter indicator shows that it is necessary to change the filter. Replace all fluid lost during filter change.



**EXCESSIVE NOISE AND /  
OR VIBRATION**

Item	Description	Action
Check fluid level in reservoir.	Insufficient hydraulic fluid causes cavitation.	Fill the reservoir to proper level.
Check for air in system.	Air in system causes noisy, erratic control.	Purge air and tighten fittings. Check inlet for leaks.
Check pump inlet pressure / vacuum.	Improper inlet conditions cause erratic behavior and low output flow.	Correct pump inlet pressure / vacuum conditions. Refer to <i>Hydraulic parameters</i> , page 10.
Inspect shaft couplings.	A loose or incorrect shaft coupling causes excessive noise and / or vibration.	Repair or replace coupling and ensure that correct coupling is used.
Check shaft alignment.	Misaligned shafts create excessive noise and / or vibration.	Correct shaft misalignment.
Hydraulic fluid viscosity above acceptable limits.	Hydraulic fluid viscosity above acceptable limits or low fluid temperature will not allow the pump to fill or control to operate properly.	Allow system to warm up before operating, or use fluid with the appropriate viscosity grade for expected operating temperatures. See <i>Hydraulic Fluids, Series 45 F Frame Technical Information Manual, 520L0948</i> .

**ACTUATOR RESPONSE IS  
SLUGGISH**

Item	Description	Action
Check external system relief valve setting.	Low external relief valve setting slows down system.	Adjust external relief valve setting following manufacturer's recommendations. External relief setting must be above PC setting to operate properly.
Check PC and LS control setting.	Low PC setting prevents the pump from achieving full stroke. Low LS setting limits output flow.	Adjust PC and LS setting. Refer to <i>Adjustments</i> , pages 22 and 23.
Check LS control signal pressures.	Incorrect LS signal will not allow pump to operate correctly.	Inspect system to ensure that proper LS signal transmit to pump.
Internal system leaks.	Worn internal parts don't allow the pump to operate properly.	Refer to Sauer-Danfoss Global Service Partner for required repair.
Hydraulic fluid viscosity above acceptable limits.	Hydraulic fluid viscosity above acceptable limits or low fluid temperature will not allow the pump to fill or control to operate properly.	Allow system to warm up before operation or sue fluid with the appropriate viscosity grade for expected operating temperatures. See <i>Hydraulic Fluids, Series 45 F Frame Technical Information Manual, 520L0948</i> .
Check external system valves.	Malfunctioning valves may not allow system to respond properly.	Repair or replace system valving as required.
Check pump case pressure.	High case pressure causes the system to be sluggish.	Correct case drain line restrictions.
Check pump inlet pressure / vacuum.	High inlet vacuum causes low output flow.	Correct inlet pressure conditions.



### SYSTEM OPERATING HOT

Item	Description	Action
Check fluid level in reservoir.	Insufficient volume of hydraulic fluid will not meet cooling demands of system.	Fill reservoir to proper level. Verify proper size of reservoir.
Inspect heat exchanger. Check air flow and input air temperature for the heat exchanger.	Insufficient air flow, high input air temperature, or undersized heat exchangers will not meet cooling demands of the system.	Clean, repair, or replace heat exchanger as required. Verify proper size of heat exchanger.
Check external system relief valve setting.	Fluid passing through relief valve adds heat to system.	Adjust external system relief valve setting following manufacturer's recommendations. External relief valve setting must be above PC setting for proper operation.
Check pump inlet pressure / vacuum.	High inlet vacuum adds heat to system.	Correct inlet pressure / vacuum conditions.

### LOW PUMP OUTPUT FLOW

Item	Description	Action
Check fluid level in reservoir.	Insufficient hydraulic fluid will limit output flow and cause internal damage to pump.	Fill the reservoir to proper level.
Hydraulic fluid viscosity above acceptable limits.	Fluid viscosity above acceptable limits or low fluid temperature will not allow the pump to fill or control to operate properly.	Allow system to warm up before operating, or use fluid with the appropriate viscosity grade for expected operating temperatures. See <i>Hydraulic fluids, Series 45 F Frame Technical Information Manual, 520L0948</i> .
Check external system relief valve setting.	External relief valve set below PC setting causes low output flow.	Adjust external relief valve following manufacturer's recommendation. External relief valve setting must be above PC setting to operate properly.
Check PC and LS control setting.	Low PC setting prevents the pump from achieving full stroke.	Adjust PC and LS setting. Refer to <i>Adjustment</i> , page 22.
Check pump inlet pressure / vacuum.	High inlet vacuum causes low output flow.	Correct inlet pressure conditions.
Check input speed.	Low input speeds decrease flow.	Adjust input speed.
Check pump rotation.	Incorrect rotational configuration causes low flow.	Use pump with appropriate rotational configuration.

### PRESSURE OR FLOW INSTABILITY

Item	Description	Action
Check for air in system.	Air in system causes erratic operation.	Activate PC allowing system to bleed air. Check inlet line for leaks and eliminate source of air ingress.
Check control spools.	Sticking control spools cause erratic operation.	Inspect spools for free movement in bore. Clean or replace.

**PRESSURE OR FLOW  
INSTABILITY  
(continued)**

Item	Description	Action
Check LS setting.	Low LS setting may cause instability.	Adjust LS setting to proper level. See <i>Adjustments</i> , page 22.
Check LS signal line.	Blocked LS signal line interferes with proper LS operation.	Remove blockage.
Check external relief valve and PC setting.	Insufficient pressure differential between PC setting and external relief valve.	Adjust external relief valve or PC control settings to appropriate level. Relief valve setting must be above PC setting to operate properly.
Check external relief valve.	Chattering external relief valve may cause unstable feedback to pump control.	Adjust or replace relief valve.

**SYSTEM PRESSURE NOT  
REACHING PC SETTING**

Item	Description	Action
Check PC control setting.	System pressure will not rise above PC setting.	Adjust PC to appropriate setting. Refer to <i>Adjustments</i> , page 22.
Check external relief valve.	External relief valve setting below PC setting prevents pressure compensation.	Adjust external relief valve according to manufacturer's recommendations. External relief valve must be set above PC setting to operate properly.
Inspect PC control spring.	Broken, damaged, or missing spring will cause erratic operation.	Replace the spring as required.
Inspect PC spool for wear.	Wear of PC spool causes internal leakage in the control.	Replace the spool as required.
Inspect PC spool for proper orientation.	Improper orientation results in poor operation.	Correct orientation of spool.
Check PC control for contamination.	Contamination may interfere with movement of the PC spool.	Clean PC control components, take appropriate action to eliminate contamination.

**HIGH INLET VACUUM**

**⚠ Caution**  
High inlet vacuum causes cavitation which can damage internal pump components.

Item	Description	Action
Check fluid temperature.	Low temperature increases viscosity. High fluid viscosity causes high inlet vacuum.	Allow system to warm up before operating.
Inspect inlet screen.	Blocked or restricted inlet screen causes high inlet vacuum.	Clean screen / remove blockage.
Check inlet piping.	Too many fittings, bends, or long piping causes high inlet vacuum.	Eliminate fittings to make path more direct.
Hydraulic fluid viscosity above acceptable limits.	High fluid viscosity causes high inlet vacuum.	Select fluid with appropriate viscosity for expected operating temperature. See <i>Hydraulic fluids, Series 45 F Frame Technical Information Manual, 520L0948</i> .



**PC CONTROL**

PC setting is indicated in the pump model code. Refer to the *Series 45 Frame F Open Circuit Axial Piston Pumps Technical Information Manual*, **520L0948**, for more information.

Before performing adjustments, read page 16, *Pressure measurement*.

**▲ Warning**  
Escaping hydraulic fluid under pressure can have sufficient force to penetrate your skin causing serious injury and/or infection. Relieve pressure in the system before removing hoses, fittings, gauges, or components.

Unintended movement of the machine or mechanism may cause injury to the technician or bystanders. To protect against unintended movement, secure the machine or disable / disconnect the mechanism while servicing.

1. Install a pressure gauge in port M2 to measure system pressure. Install a pressure gauge in case drain port L1 or L2 to measure case pressure. **▲ !**
2. Start the prime mover and allow fluid to reach normal operating temperature. Operate a hydraulic function to its full extension, loading the pump to maximum pressure and zero flow.
3. Loosen the PC set screw and turn the PC adjusting plug until the gauge at port M2 indicates the desired setting<sup>1</sup>. Clockwise rotation increases pressure, counterclockwise rotation decreases; approximate gain 42 bar [610 psi] per turn.

*PC control adjustment*

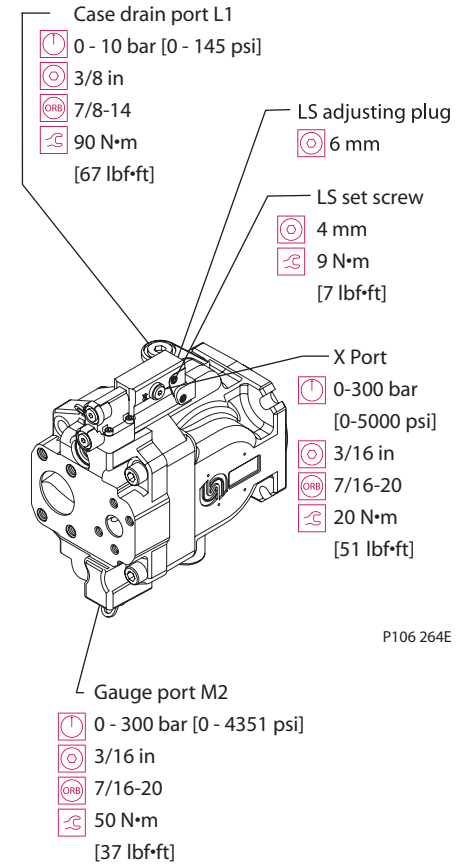

P106 264E

If the pressure does not increase, an external system relief valve may require adjustment. External system relief valve must be set above the PC setting for proper operation.

**! Caution**  
Contamination can damage internal components and void the manufacturer's warranty. Take precautions to ensure system cleanliness when removing and reinstalling system lines.

4. While holding the position of the PC adjusting plug, torque the PC set screw to 9 N•m [7 lbf•ft].
5. Stop the prime mover, remove the pressure gauges, and return the system to its normal operating configuration.

*Pressure change*

Control option	PC adjustment	LS adjustment
LS, LD, LB, LE, PC, RP	42 bar/rev [609 PSI/rev]	17.2 bar/rev [250 PSI/rev]
BB, BC, BP, BS	36 bar/rev [534 PSI/rev]	
AB, AC, AD, AJ, AS	8.5 bar/rev [123 PSI/rev]	

<sup>1</sup> P C setting is referenced to case pressure. Subtract case pressure from system pressure to compute the actual setting.

### LS CONTROL

**▲ Warning**  
Escaping hydraulic fluid under pressure can have sufficient force to penetrate your skin causing serious injury and/or infection. Relieve pressure in the system before removing hoses, fittings, gauges, or components.

Unintended movement of the machine or mechanism may cause injury to the technician or bystanders. To protect against unintended movement, secure the machine or disable / disconnect the mechanism while servicing.

**⚠ Caution**  
Contamination can damage internal components and void the manufacturer's warranty. Take precautions to ensure system cleanliness when removing and reinstalling system lines.

If the pressure does not increase, an external system relief valve may require adjustment. External system relief valve must be set above the PC setting for proper operation.

The LS setting is indicated in the pump model code. Refer to the *Series 45 Frame F Open Circuit Axial Piston Pumps Technical Information Manual, 520L0948*, for more information.

Before performing adjustments, read page 16, *Pressure measurement*.

1. Install a pressure gauge in port M2 to measure system pressure. Install a pressure gauge in drain port L1 or L2 to measure case pressure. Tee-in a gauge to the LS / remote PC signal line (port X). **▲ ⚠**
2. Start the prime mover and allow fluid to reach normal operating temperature. Slowly operate a hydraulic function that will demand approximately half flow from the pump, but keep system pressure below the PC set point.
3. Loosen the LS set screw. While watching the pressure gauges, turn the LS adjusting plug until the desired pressure differential between port M2 and port X is achieved<sup>1</sup>. Clockwise rotation increases the setting, counterclockwise rotation decreases it; approximate gain = 17 bar [250 psi] per turn.
4. While holding the position of the LS adjusting plug, torque the LS set screw to 9 N•m [7 lbf•ft].
5. Operate a hydraulic function to its full extension loading the pump at maximum pressure and zero flow.
6. Loosen the PC set screw and turn the PC adjusting plug until the pressure gauge at port M1 or M2 indicates the desired setting<sup>2</sup>. Clockwise rotation increases pressure, counterclockwise rotation decreases it; approximate gain = 42 bar [610 psi] per turn.
7. While holding the position of the PC adjusting plug, torque the PC set screw to 9 N•m [7 lbf•ft].
8. Stop the prime mover, remove the pressure gauges, and return the system to its normal operating configuration.

### LS control adjustment

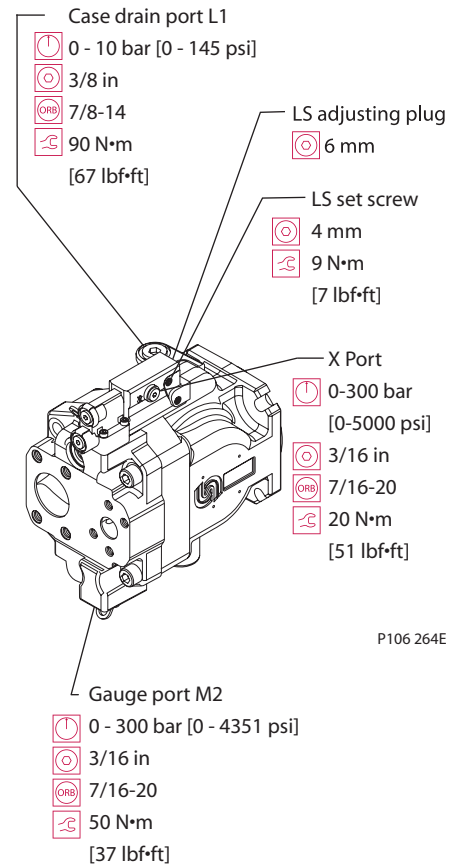

P106 264E

### Adjusting plug, set screw, and gauge locations shown

<sup>1</sup> The LS setting is a differential pressure. Subtract pilot pressure at port X from system pressure at port M2 to compute the actual setting.  
<sup>2</sup> PC setting is referenced to case pressure. Subtract case pressure from system pressure to compute the actual setting.



**SHAFT SEAL  
 REPLACEMENT**

The Series 45 open circuit variable pumps use a lip-type shaft seal. You can replace this seal without major disassembly of the unit. Replacing the shaft seal requires removing the pump from the machine.

**Removal**

1. Using the appropriate snap-ring pliers, remove the retaining ring (K010) from the housing.
2. Remove the shaft seal (K020) from the bore in the pump housing and discard. ⚠

⚠ **Caution**  
 Don't damage the pump housing or shaft.

Puncture the face of the seal with a packing hook, or use a slide-hammer type puller to remove the seal.

**Installation**

3. Inspect the pump housing and new seal for damage. Inspect the sealing area on the shaft for rust, wear, or contamination. Polish the sealing area on the shaft if necessary.
4. Lubricate the lip of the new shaft seal with clean hydraulic fluid. Place a protective sleeve over the shaft end to prevent damage to the seal during installation.
5. Keeping the seal perpendicular to the shaft, press the new seal into the housing just far enough to clear the retaining ring groove. ⚠ Install seal with the cupped side toward the shaft bearing. Do not damage the seal during installation.
6. Using the appropriate snap ring pliers, install the seal retaining ring.
7. Remove the installation sleeve.

⚠ **Caution**  
 Premature bearing failure can result if the shaft seal contacts the shaft bearing. Press the seal into the housing only far enough to clear the retaining ring groove.

*Shaft seal and retaining ring*

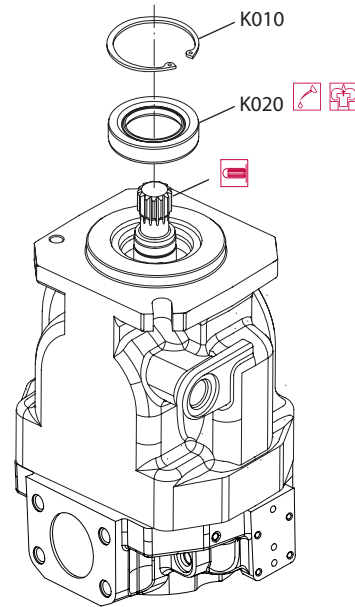

E101 254



## AUXILIARY PADS

You may install auxiliary mounting pads on pumps equipped with through-drive radial ported end caps. Follow these steps to either remove, replace, or exchange auxiliary mounting pads.

### Removal

1. Remove the screws (J130), retaining the cover plate (J110) or auxiliary pump (not shown). Remove the shipping cover or auxiliary pump and its seal (J120).
2. Remove the drive coupling (J140) if present.
3. Remove the 4 screws (J100) retaining the pad adapter (J080) to the endcap. Discard the pad adapter O-ring (J090) if present.

### Installation

4. Lubricate new O-ring (J090) with petroleum jelly. Install the pad adapter to the endcap.
5. Install the 4 screws (J100) and torque to 55 N•m [40 lbf•ft].
6. Install the drive coupling (J140) if present.
7. Install shipping cover or auxiliary pump with seal (J120). **⚠**
8. Install the screws (J130) and torque to 105 N•m [77 lbf•ft].

**⚠ Caution**  
Shipping cover is intended only to retain coupling during shipment and storage. Do not operate pump with coupling and shipping cover installed.

### Auxiliary mounting pads

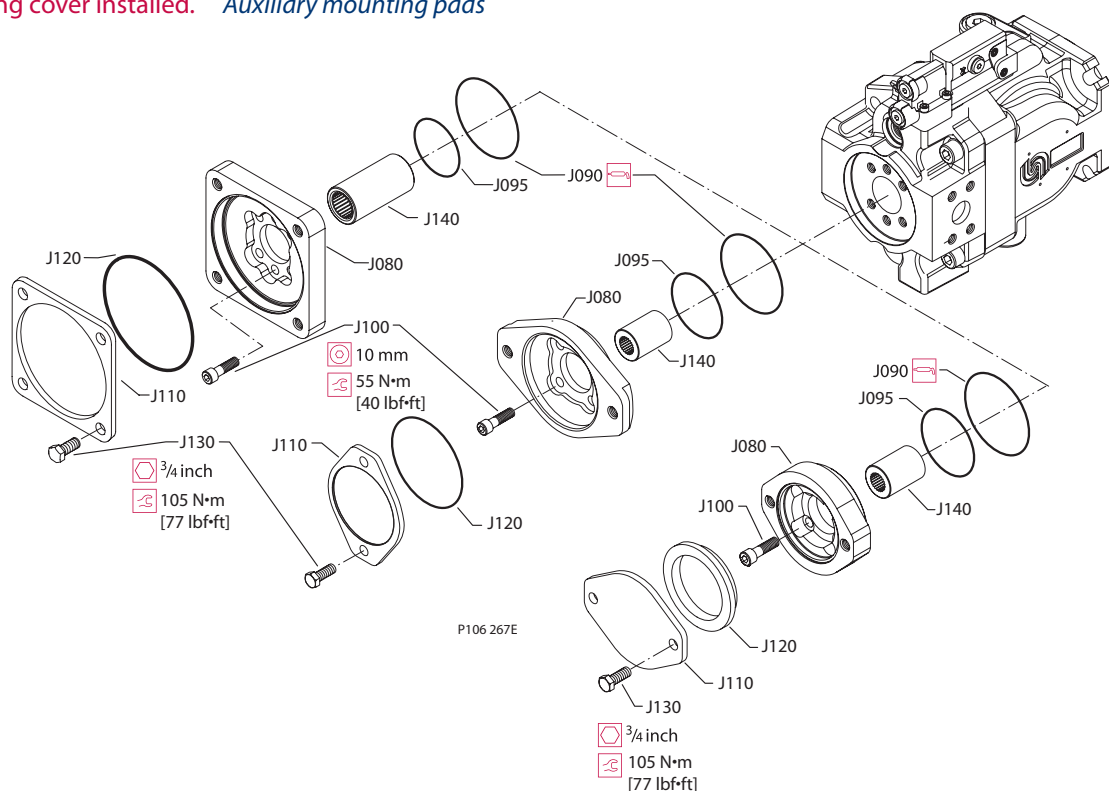

## LS AND PC CONTROLS

### Disassembly

1. Remove the 4 screws (C300) holding the control housing onto the endcap.
2. Remove the control and discard the 4 interface O-rings (C200).
3. Remove the PC set screw (C102), PC adjusting plug (C138), O-ring (C138A), springs (C134, C135), and seat (C133). Discard the O-ring.
4. Remove the plug (C103), O-ring (C103A), and PC spool (C132) from the control housing. Discard the O-ring. Note orientation of the spool for reassembly.

For PC only controls, skip steps 5 through 7

5. Remove the plug (C105) and O-ring (C105A), or the plug (C106) and O-ring (C106A). Discard the O-ring (C105A or C106A).
6. Remove the LS set screw (C102), LS adjusting plug (C118), O-ring (C118A), back-up rings (C118B), springs (C114, C115), and seat (C113). Discard the O-ring and backup rings.
7. Remove the plug (C104), O-ring (C104A), and LS spool (C112) from the control housing; discard the O-ring. Note orientation of the spool for reassembly.

### Inspection

8. Inspect the adjusting plugs for wear at the tips and where they contact the seat; replace as necessary.
9. Inspect the springs and spring guides for wear or damage; replace as necessary.
10. Carefully inspect the spools. Ensure the sealing lands are free of nicks and scratches. Check the ends that contact the spring guides for wear. Replace spools as necessary.
11. Inspect the control housing for damage. Check the spool bores for excessive wear.
12. Clean all parts and lubricate spools, springs, guides, and new O-rings with clean hydraulic fluid.

### Control assembly

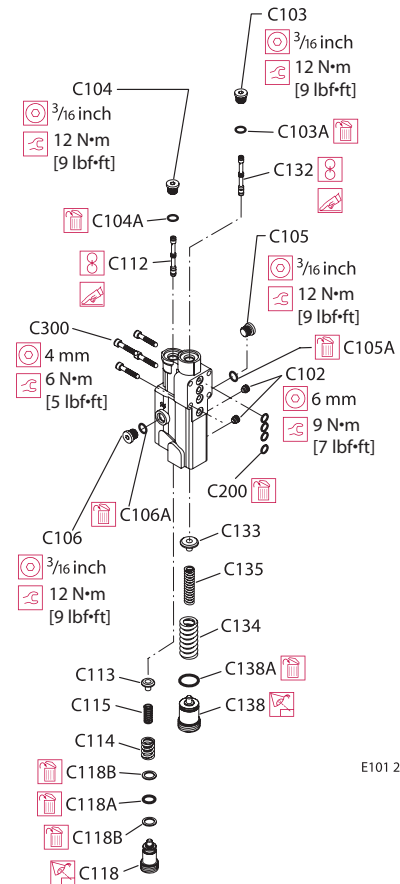

E101 226

**LS control shown; parts C104 through C106 and C112 through C118 are not used on PC control**

**LS AND PC CONTROLS  
(continued)**

**Reassembly**

13. Install the PC spool (C132), spherical end first, into the PC bore. Using a new O-ring (C103A), install the plug (C103). Torque the plug (C103) to 12 N•m [9 lbf•ft].
14. Place the two PC springs (C134, C135) onto the spring guide (C133) and install into the PC bore. Place a new O-ring (C138A) onto the PC adjusting screw and thread it into the PC bore until flush, then make another full turn. Install and torque the PC set screw (C102) to 9 N•m [7 lbf•ft].

For PC only controls, skip steps 15 through 17.

15. Install the LS spool (C112), spherical end first, into the LS bore. Using a new O-ring (C105A or C106A), install the plug (C105 or C106). Torque the plug (C105 or C106) to 12 N•m [9 lbf•ft].
16. Using a new O-ring (C104A), install the plug (C104). Torque the plug to 12 N•m [9 lbf•ft].
17. Place the two LS springs (C114, C115) onto the spring guide (C113) and install into the LS bore. Place a new O-ring (C118A) and back-up rings (C118B) onto the LS adjusting screw and thread it into the LS bore until flush, then make another full turn. Install and torque the LS set screw (C102) to 9 N•m [7 lbf•ft].
18. Using petroleum jelly to retain them, install 4 new interface O-rings (C200) in the recesses on the control housing.
19. Install the control assembly onto the endcap using the 4 screws (C300). Torque the screws to 6 N•m [5 lbf•ft]. Torque screws in a criss-cross pattern and re-torque the first screw to ensure proper torque retention.
20. Check and adjust the control setting. See *Adjustments*, page 22.

*Control assembly*

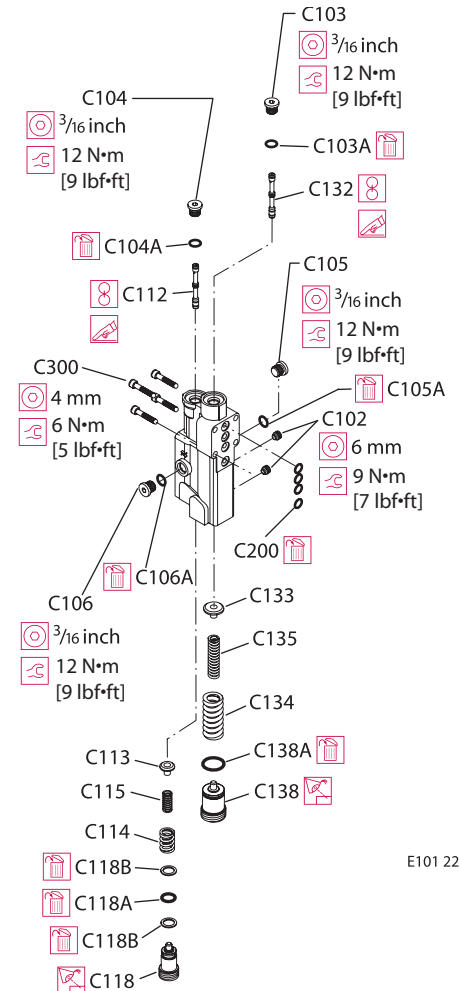

E101 226

**LS control shown; parts C104 through C106 and C112 through C118 are not used on PC control**

**ELECTRIC CONTROLS**

**Disassembly**

1. Remove four screws (C300).
2. Remove the control and discard the four O-rings (C200).
3. Remove set screws (C102), PC adjusting plug (C138) with O-ring (C138A), springs (C134, C135), and seat (C133). Discard the O-ring if it is damaged.
4. Remove plug (C103). Remove PC spool (C132). Note orientation of the spool for reassembly.
5. Remove plug (G030), and orifice (G020).
6. Remove LS adjusting plug (C118), springs (C114, C115), and seat (C113).
7. Remove plug (C104), and spool (C112). Note the orientation of the spool for reassembly.
8. Remove four screws (C151). Remove the manifold (C152) and discard the two interface O-rings (C154).
9. For electric proportional controls only:  
 Remove the electric control manifold drain orifice (C149).
10. Remove plug (C153). Remove the cartridge valve nut (C125), electric solenoid (C155), and cartridge valve (C150) from the electric control manifold.

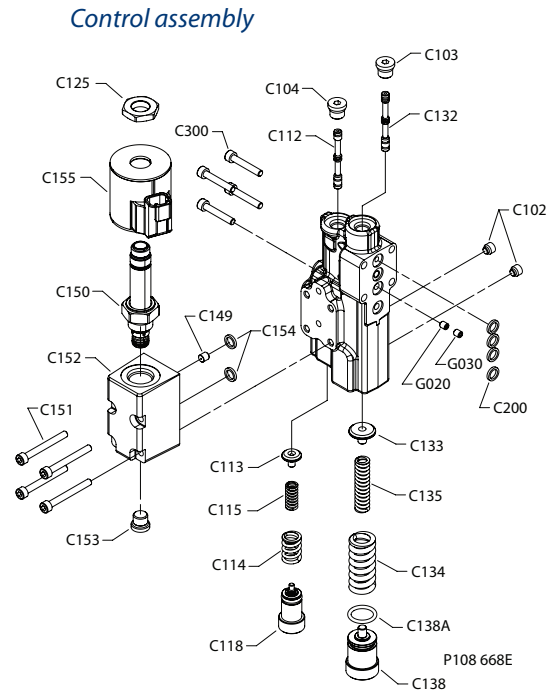

**Inspection**

1. Inspect the adjusting plugs for wear at the tips and where they contact the springs; replace as necessary.
2. Inspect the springs and spring guides for wear or damage; replace as necessary.
3. Carefully inspect the spools. Ensure the sealing lands are free of nicks and scratches. Check the ends that contact the spring guides for wear. Replace spools as necessary.
4. Inspect the control housing for damage. Check the spool bores for excessive wear.
5. Remove debris from orifices if necessary. Ensure the servo control orifice backup plug is clean, and remove debris if necessary.
6. Clean all parts and lubricate spools, springs, guides and new O-rings with clean hydraulic fluid.



**ELECTRIC CONTROLS**  
(continued)

**Reassembly**

1. Install the servo control orifice (G020), and torque to 2-3.4 N•m [18-30 in•lb]. Then install the orifice backup plug (G030), and torque to 2-3.4 N•m [18-30 in•lb].
2. Install the PC spool (C132), spherical end first, into the PC bore. Install plug (C103). Torque the plug to 10.8 - 13.5 N•m [8 - 10 lbf•ft].
3. Place the two PC springs (C134, C135) onto the spring guide (C133) and install into the PC bore. Place a new O-ring (C138A) onto the PC adjusting screw (C138) and thread it into the PC bore until flush, then make another full turn. Install and torque the PC set screw (C102) to 7.5 - 10.8 N•m [5.5-8 lbf•ft].
4. Install the LS spool (C112), spherical end first, into the LS bore.
5. Install plug (C104). Torque the plug to 10.8 - 13.5 N•m [8 - 10 lbf•ft].
6. Place the two LS springs (C114, C115) onto the spring guide (C113) and install into the LS bore. Thread adjusting screw (C118) into the LS bore until flush, then make another full turn. Install and torque the LS set screw (C102) to 7.5 - 10.8 N•m [5.5-8 lbf•ft].
7. Install the electric control manifold drain orifice (C149) and torque to 2-3.4 N•m [18-30 in•lb].
8. Install the cartridge valve (C150) into the electric control manifold (C152). Torque to 25.8-28.5 N•m [19-21 lbf•ft]. DO NOT OVERTORQUE the cartridge valve.
9. Install the electric solenoid (C155), and solenoid coil nut (C125). Torque to 6.8-9.5 N•m [5-7 lbf•ft].
10. Install plug (C153). Torque the plug to 10.8 - 13.5 N•m [8 - 10 lbf•ft].
11. Using petroleum jelly to retain them, install the two interface O-rings (C154) in the recesses on the electric control manifold.
12. Install the manifold assembly onto the control housing using four screws (C151). Torque the screws to 5.4 - 7.5 N•m [4 - 5.5 lbf•ft]. Torque the screws in a criss-cross pattern and re-torque the first screw to ensure proper torque retention.
13. Using petroleum jelly to retain them, install the four interface O-rings (C200) in the recesses on the control housing.
14. Install the control assembly onto the endcap using the four screws (C300). Torque the screws to 5.4 - 7.5 N•m [4 - 5.5 lbf•ft]. Torque screws in a criss-cross pattern and re-torque the first screw to ensure proper torque retention.
15. Check and adjust the control setting. See *Adjustments*, page 23-24.

**SERVO CONTROL ORIFICE**

**Disassembly**

1. Remove four screws (C300).
2. Remove the control and discard the four O-rings (C200).
3. Remove PC plug (C103), and PC spool (C132) from the control housing.

---

Note the orientation of the spool for reassembly.

---

4. Remove backup plug (G030), and orifice (G020).

**Reassembly**

1. Install the orifice (G020), and torque to 2-3.4 N•m [18-30 in•lb]. Then install the orifice backup plug (G030), and torque to 2-3.4 N•m [18-30 in•lb].
2. Install the PC spool (C132), spherical end first, into the PC bore. Install plug (C103). Torque the plug to 10.8 - 13.5 N•m [8 - 10 lbf•ft].
3. Using petroleum jelly to retain them, install the four O-rings (C200) in the recesses on the control housing.
4. Install the control assembly onto the endcap using four screws (C300). Torque the screws to 5.4 - 7.5 N•m [4 - 5.5 lbf•ft]. Torque screws in a criss-cross pattern and re-torque the first screw to ensure proper torque retention.

*Control assembly*

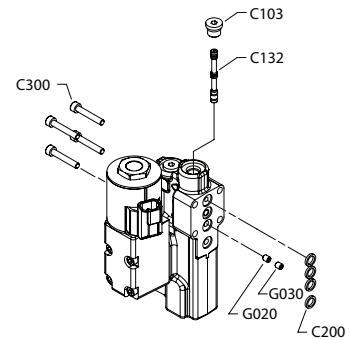

P108 669E

**PLUG AND FITTING SIZES  
AND TORQUES**

If any plugs or fittings are removed from the unit during service, install and torque as indicated here. This drawing is a composite. Individual pump configurations may be different. The illustration below shows the appropriate wrench size and torque for plugs that may be installed in the pump:

*Plug locations, sizes, and torques*

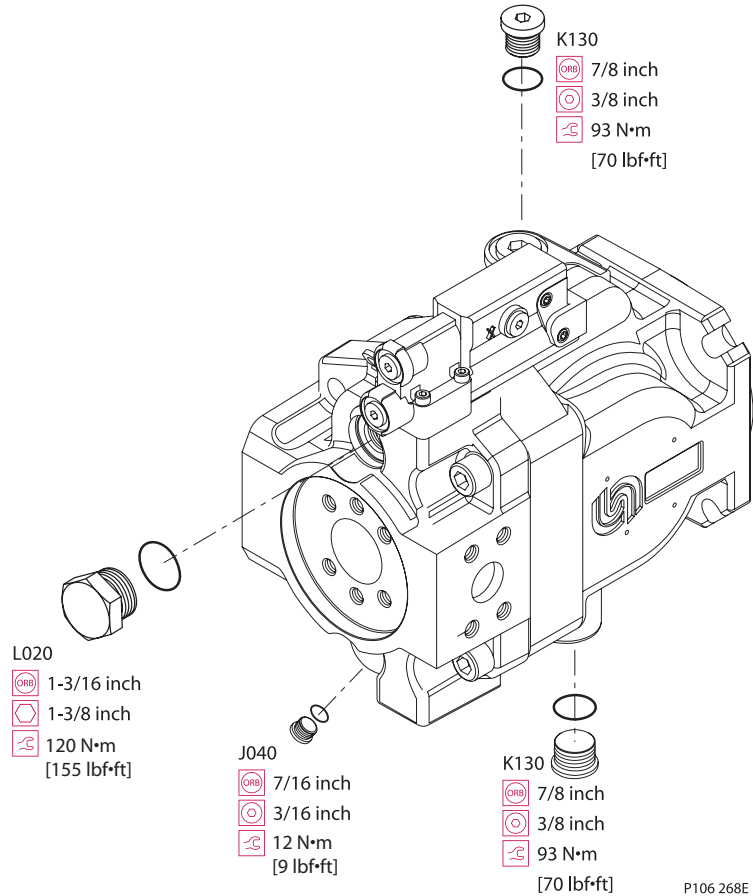

P106 268E



**Products we offer:**

- Bent Axis Motors
- Closed Circuit Axial Piston Pumps and Motors
- Displays
- Electrohydraulic Power Steering
- Electrohydraulics
- Hydraulic Power Steering
- Integrated Systems
- Joysticks and Control Handles
- Microcontrollers and Software
- Open Circuit Axial Piston Pumps
- Orbital Motors
- PLUS+1™ GUIDE
- Proportional Valves
- Sensors
- Steering
- Transit Mixer Drives

**Members of the Sauer-Danfoss Group:**

**Comatrol**

[www.comatrol.com](http://www.comatrol.com)

**Schwarz Müller-Inverter**

[www.schwarzmueller-inverter.com](http://www.schwarzmueller-inverter.com)

**Turolla**

[www.turollaocg.com](http://www.turollaocg.com)

**Hydro-Gear**

[www.hydro-gear.com](http://www.hydro-gear.com)

**Sauer-Danfoss-Daikin**

[www.sauer-danfoss-daikin.com](http://www.sauer-danfoss-daikin.com)

**Sauer-Danfoss** is a global manufacturer and supplier of high-quality hydraulic and electronic components. We specialize in providing state-of-the-art technology and solutions that excel in the harsh operating conditions of the mobile off-highway market. Building on our extensive applications expertise, we work closely with our customers to ensure exceptional performance for a broad range of off-highway vehicles.

We help OEMs around the world speed up system development, reduce costs and bring vehicles to market faster.

Sauer-Danfoss – Your Strongest Partner in Mobile Hydraulics.

**Go to [www.sauer-danfoss.com](http://www.sauer-danfoss.com) for further product information.**

Wherever off-highway vehicles are at work, so is Sauer-Danfoss.

We offer expert worldwide support for our customers, ensuring the best possible solutions for outstanding performance. And with an extensive network of Global Service Partners, we also provide comprehensive global service for all of our components.

Please contact the Sauer-Danfoss representative nearest you.

Local address:

Sauer-Danfoss (US) Company  
2800 East 13th Street  
Ames, IA 50010, USA  
Phone: +1 515 239 6000  
Fax: +1 515 239 6618

Sauer-Danfoss ApS  
DK-6430 Nordborg, Denmark  
Phone: +45 7488 4444  
Fax: +45 7488 4400

Sauer-Danfoss GmbH & Co. OHG  
Postfach 2460, D-24531 Neumünster  
Krokamp 35, D-24539 Neumünster, Germany  
Phone: +49 4321 871 0  
Fax: +49 4321 871 122

Sauer-Danfoss-Daikin LTD.  
Shin-Osaka TERASAKI 3rd Bldg. 6F  
1-5-28 Nishimiyahara, Yodogawa-ku  
Osaka 532-0004, Japan  
Phone: +81 6 6395 6066  
Fax: +81 6 6395 8585