

# *Home Refueling Appliance for CNG vehicles Mod. HRA G 1.5 P30 & P36*



## **User's Manual**

**This Home Refuelling Appliance (HRA) should only be installed and serviced by authorized and trained personnel.**

STAMP OF AUTHORIZED TECHNICAL SERVICE

**BRC - FuelMaker - M.T.M. S.r.l. U.**  
**Via Industria, 6 - 12062 - Cherasco - CN - ITALY**  
**International Technical Assistance**  
**Tel. +39.0172.48.68.628 0172.48.68.363 - 0172.48.68.623.- Fax +39.0172.486.630**  
**e-mail: [compressorservice@brc.it](mailto:compressorservice@brc.it) - [www.brcfuelmaker.it](http://www.brcfuelmaker.it)**  
**North America – Canada Technical Assistance**  
**Tel. +1.705.341.19.23**  
**e-mail: [d.stubbings@brc.it](mailto:d.stubbings@brc.it)**

**SUMMARY**

1. SAFETY INSTRUCTIONS ..... 4

2. INTRODUCTION ..... 6

3. PHILL MODELS ..... 6

4. TECHNICAL SPECIFICATIONS ..... 7

5. GENERAL INFORMATION ..... 7

6. FUNCTIONS OF USER’S CONTROL PANEL .....10

7. MAINTENANCE INSTRUCTIONS.....17

8. HRA REMOVAL .....17

9. DISPOSAL.....18

10. WARRANTY CERTIFICATE .....19

11. CE CONFORMITY DECLARATION .....20

12. CERTIFICATE SIL 1 .....22

**TABLES SUMMARY**

TABELLA 1 - PHILL MODELS ..... 6

TABELLA 2 - TECHNICAL SPECIFICATION ..... 7

TABELLA 3 – COMPENSATION PRESSURE / TEMPERATURE ..... 9

TABELLA 4 -WORKING HOURS CODES ..... 11

TABELLA 5 - *ERRORS DIAGNOSTICS*..... 12

# 1. SAFETY INSTRUCTIONS

## **COMPONENTS ARE NON REPLACEABLE BY USER**

USERS SHOULD NOT CARRY OUT ANY MAINTENANCE ON INTERNAL COMPONENTS.

Internal components should only be maintained and overhauled at BRC FuelMaker's premises or by authorized dealers.

Do not open or tamper with modules or the warranty will be invalidated; tampering with or opening modules could be dangerous and cause damage to the compressor and cause serious injury or even death.

## **READ CAREFULLY BEFORE INSTALLATION**

HRAs should only be installed by trained and personnel authorized by BRC FuelMaker.

Please read carefully the manual provided before installation and use.

If you have any questions or concerns during installation, please contact your local BRC FuelMaker Distributor.

## **LOCATION OF Home Refueling Appliance (HRA)**

HRAs can be installed both indoors (Garage) and outdoors in safe and protected areas as per installation instructions and local jurisdictional codes.

The HRA and vehicle have to be located in the same ambient temperature during the refuelling operation to ensure correct temperature compensation.

See Table 2 for temperature compensated maximum fuelling pressures.

## **REFUELING APPLIANCE FOR CNG (Compressed Natural Gas) VEHICLES ONLY**

Do not use HRA for any other purpose or it may result in serious injury and/or death to and also cause serious damage to structures. Vehicle gas cylinder should be certified for storing CNG at a 3600 psig or 250 Bar pressure or higher. HRA is suitable for residential applications, and all installations must comply with installation manuals and local jurisdictional code requirements.

## **REFUELING INSTRUCTIONS**

Do not refuel with engine turned on and be sure that any possible ignition source is absent. Do not smoke or expose to open flames during refuelling.

## **IF YOU SMELL GAS**

Open all windows and doors in the location of the HRA if the unit is installed indoors.

Immediately close the manual valve on natural gas supply line; and, if possible, the valve on the vehicle cylinder. Switch off any possible ignition sources and contact an Authorized Service Centre.

## **REFUELING HOSE**

The refuelling hose must be protected from damage and abrasion. After refuelling your car, ensure that the refuelling nozzle is returned to its' holder. In case of hose and connector abrasions or wear, contact your Authorized Technical Centre for service.



**WARNING : DO NOT USE SOLVENT OR AGGRESSIVE CHEMICAL AGENTS FOR CLEANING THE OUTSIDE. USE ONLY GENTLE DETERGENTS OR SOAP.**

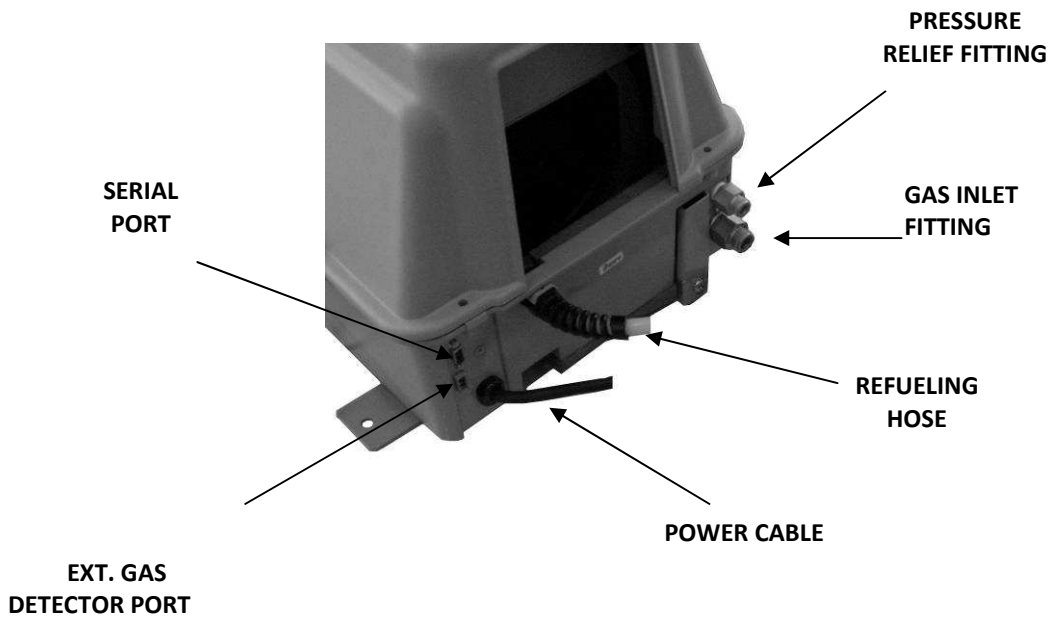
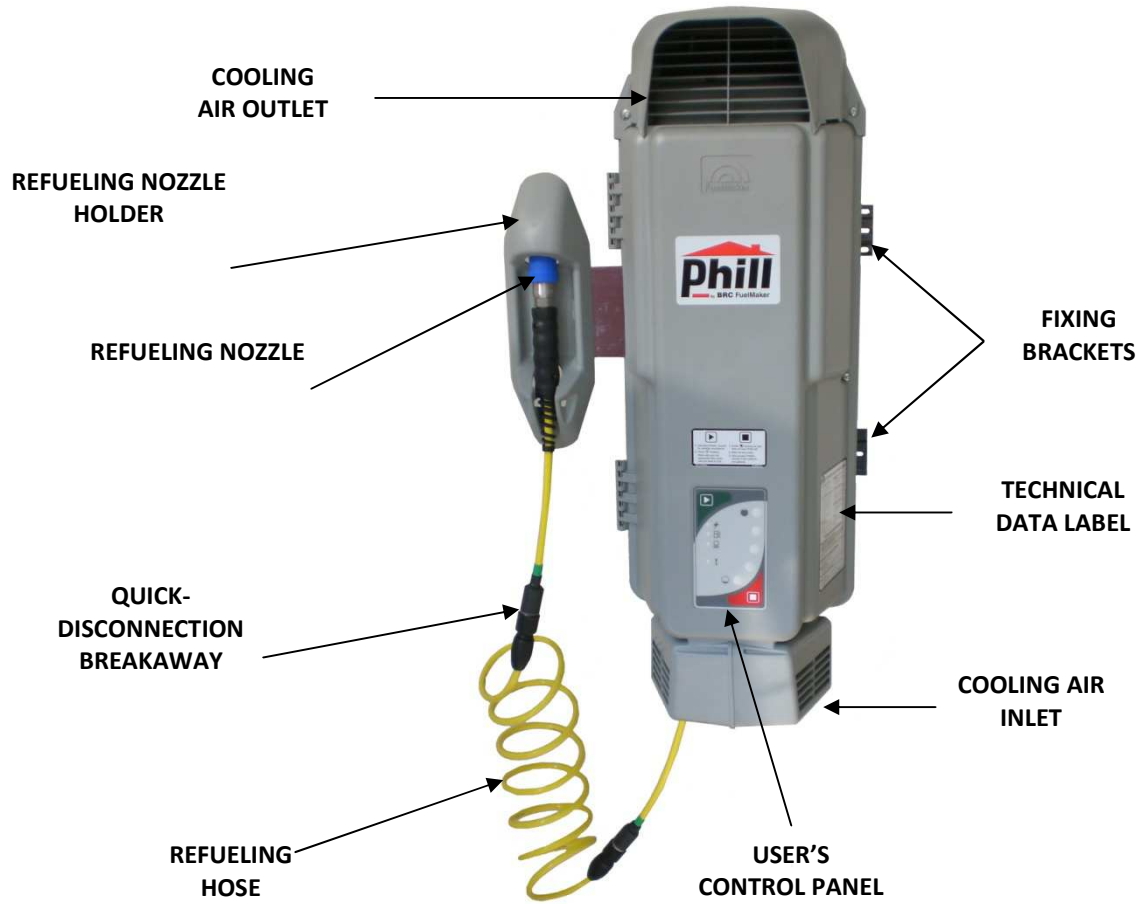

## 2. INTRODUCTION

HRA has been developed for both indoors (Garage) and outdoors installation, for compressing Natural Gas for vehicle use.

Model P30 is designed to refuel at a pressure of 207 bar/3,000 psi at 20° C/68° F (ambient temperature) with a Nominal Flow of 1,3 sm<sup>3</sup>/h at 50 Hz (1.01 scfm-0.5 GGE/h at 60 Hz).

Model P36 is designed to refuel at a pressure of 248 bar/3,600 psi at 15° C/59° F (ambient temperature) with a Nominal Flow of 1,3 sm<sup>3</sup>/h at 50 Hz (1.01 scfm-0.5 GGE/h at 60 Hz).

A HRA is equipped with Internal Gas Sensor/Air Flow Switch and Internal Dryer.

## 3. PHILL MODELS

CODE	E77HRAG15P30	E77HRAG15P36	E77HRAG15P30B	E77HRAG15P36B	E77HRAG15P30L	E77HRAG15P36L
MODEL	HRA P30 Gen 1.5	HRA P36 Gen 1.5	HRA P30 Gen 1.5	HRA P36 Gen 1.5	HRA P30 Gen 1.5	HRA P36 Gen 1.5
DESCRIPTION	STANDARD (FULL EQUIPPED)		BASIC		SMART	
LOCATION	Indoor / outdoor	Indoor / outdoor	Indoor / outdoor	Indoor / outdoor	Outdoor	Outdoor
INTERNAL DEVICES						
Internal Gas Detector	YES	YES	YES	YES	NO	NO
Air Flow switch	YES	YES	YES	YES	NO	NO
Gas Dryer	YES	YES	NO	NO	NO	NO

Tabella 1 - Phill models



**WARNING** Phill models without the gas dryer (Smart and Basic) are available but they can be used only if the gas is already dried. We recommend to use gas with dew point at the maximum delivery pressure of 5°C lower than the minimum ambient temperature.



**WARNING** In case of outdoor installation with adequate ventilation the Phill Smart use without the internal gas detector is allowed

The Phill software is designed for the constant monitoring of the all compressor components The software checks for pressure increase as well as the maximum filling pressure compensation in reference to the ambient temperature in order to avoid overpressures due to external temperature rising after filling. The automatic compensation system is determined by the temperature sensor installed on the main board (function activated by the manufacturer).

The Phill is air cooled and operates operating temperature between -40°C/-40°F and +45°C/113°F.

The Phill ventilation system operates through a fan located in the compressor lower side. The cooling air inlet is equipped with a grid while the exhaust is located in the compressor upper side or rear side.

Start, stop, and monitoring are performed by the User Control Panel.

## 4. TECHNICAL SPECIFICATIONS

1.

<b>GAS CIRCUIT</b>	
Max Filling Pressure	<b>207 bar (3,000 psig) at 20° C (68°F) ambient 248 bar (3,600 psig) at 15° C (59°F) ambient</b>
Min Inlet Pressure	<b>17 mbar (7" w.c.)</b>
Max Inlet Pressure	<b>35 mbar (14" w.c.)</b>
Nominal Flow	<b>1.3 sm<sup>3</sup>/h at 21° C / 15°C - 0.017 bar inlet 1.01 scfm-0.5 GGE/h @ 70°F/59°F-7" w.c.</b>
<b>WIRING CIRCUIT</b>	
Electrical Supply	<b>220-240 Volt AC Single Phase, 50/60 Hz</b>
Wiring Circuit Capacity	<b>15 Amp</b>
Full Load Amperes	<b>5.5/5.0 Amp</b>
Average Consumption	<b>0.85 kWh</b>
<b>MECHANICS</b>	
Dimensions (L x P x A)	<b>762 x 356 x 330 mm (30"x14"x13")</b>
Weight	<b>49 Kg/110 lb (packaging included )</b>
Noise	<b>40 dBa at 5 m/16.5 ft.</b>
Covering Protection Level	<b>IP 24</b>
Operating Temperature	<b>From - 40° C to + 46° C (-40°F +115°F)</b>

**Tabella 2 - Technical specification**

## 5. General information

### - Vehicle Refuelling Point

HRA must be installed in the same location and ambient temperature as the vehicle to be refuelled to ensure that the correct temperature compensated pressure is delivered to the vehicle; always consider the max length of refuelling hose and ensure that the refuelling hose does not obstruct pedestrian crossings or passageways.

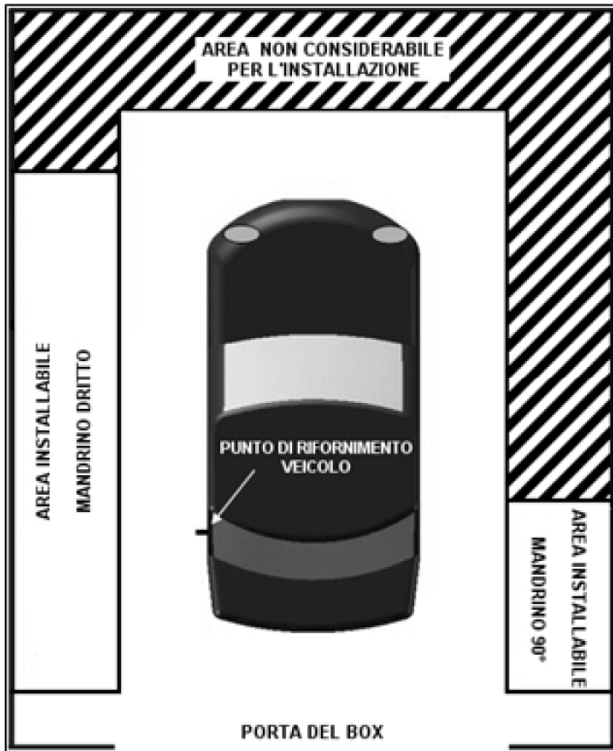

Example for refueling point

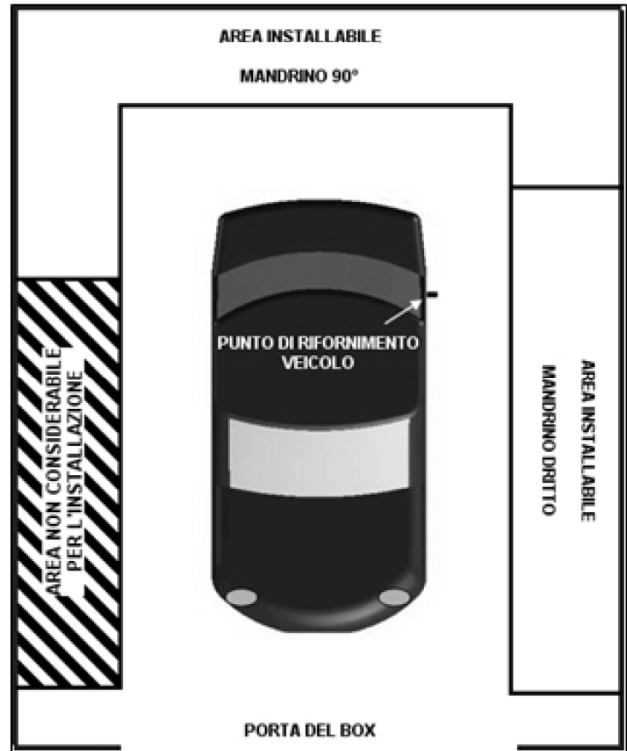

Example for refueling point

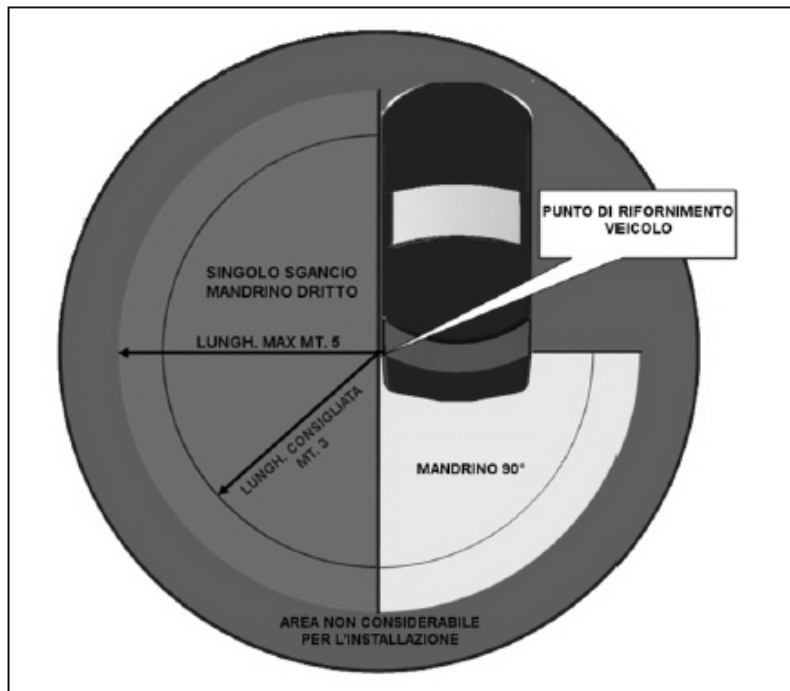

Max distances

**- Impact Protection**

HRA should be installed 1,5 mt-5 ft high from the floor so that there will no risk of collision with vehicle. In case of a bigger vehicle, such as VAN or SUV, additional impact protection may be required (see pict. 5). Local utilities and codes should be consulted.



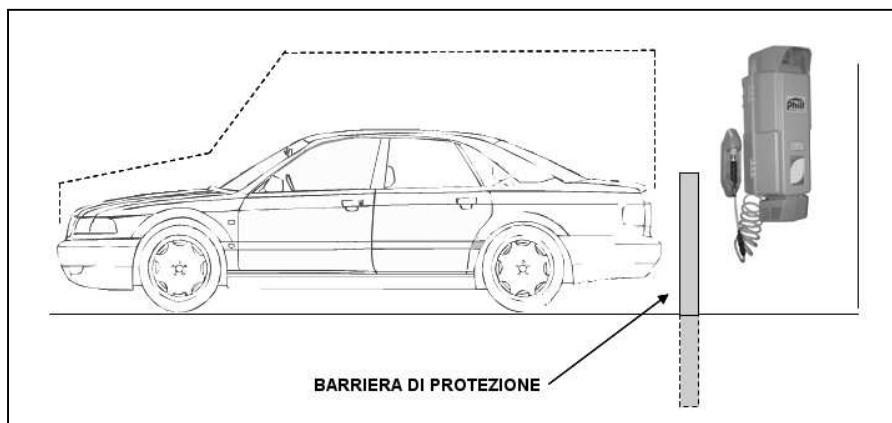

**Protection against Bumps**

**- Refueling Hose**

The HRA refuelling hose must be replaced by authorized personnel trained by BRC-FuelMaker. It can only be replaced using the correct hose manufactured for use with the HRA to prevent serious injury and or death and damage to property. A quick disconnect breakaway device is installed in the case of a vehicle driving away when the refuelling hose is still connected. It parts in two to avoid uprooting HRA from its support, leaving the end of the hose connected to the vehicle. In the case of a drive away with the hose connected, the hose should only be removed from the vehicle by an authorized service personnel . Call technical service, do not try to remove fitting to avoid damages and/or injuries.

**- Pressure Relief**

A pressure relief line allows discharging of natural gas in the unlikely event that the system overpressures; it is important keep the pressure relief line free from dirt, material or ice.

**- External gas sensor**

HRA can be equipped with an External Gas Sensor (*Optional*) if necessary or required by local code. The External Gas Sensor is connected to the port situated in the lower side of HRA. Once the sensor installed, it will have to be enabled in the software by an authorized installation technician.

If ambient temperature detected is lower than - 40° C/-40° F or higher than +45° C/113° F the software will not allow the HRA to start for safety reasons and an error will be indicated by the User’s Control Panel.

Pressure P30	Pressure P36	Ambient Temperature
207 ± 7bar (3,000± 100 psi)	248 ± 7.0 bar (3,600 ± 100 psi)	21° / 15° C (70° / 59° F) or higher
183 ± 7.5 bar (2,654 ± 108 psi)	229 ± 7.5 bar (3,321 ± 108 psi)	10° C / 50° F
166 ± 8.0 bar (2,407 ± 116 psi)	211 ± 8.0 bar (3.060 ± 116 psi)	0° C / 32° F
150 ± 8.5 bar (2,175 ± 123 psi)	194 ± 8.5 bar (2,813 ± 123 psi)	- 10° C / 14° F
133 ± 9.0 bar (1,929 ± 130.5 psi)	177 ± 9.0 bar (2.567 ± 130.5 psi)	- 20° C / - -4° F
116 ± 9.5 bar (1,682 ± 137.7 psi)	160 ± 9.5 bar (2,320 ± 137.7 psi)	- 30° C / - -22° F
100 ± 10.0 bar (1,450 ± 145 psi)	143 ± 10.0 bar (2,074 ± 145 psi)	- 40° C / - -40° F

**Tabella 3 – Compensation pressure / temperature**



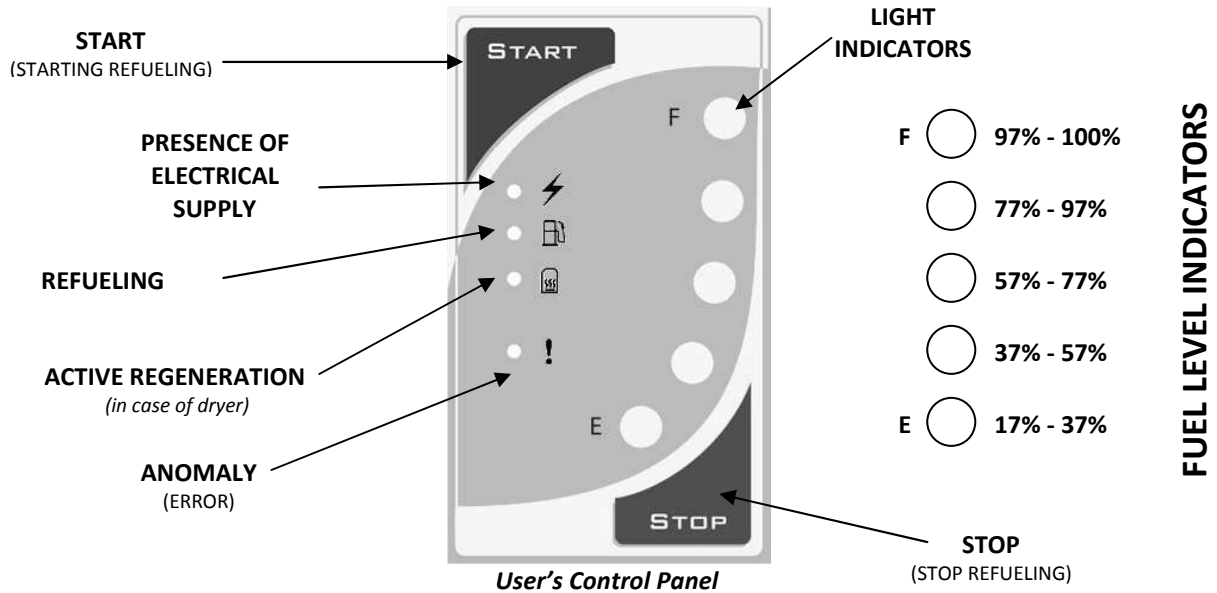

User’s should periodically check that the air inlet and exhaust system are free from dirt or obstruction; that the refuelling hose does not have abrasions, is kinked or have signs of breakage; and that vehicle storage system is tested and compliant to safety regulations.

## 6. FUNCTIONS OF USER'S CONTROL PANEL

Through the User's Panel, you can Start or manually Stop the unit. The Panel has a START button and a STOP button, three LEDs on the left showing State of the unit - Presence of Electrical Supply, Refuelling, Active Regeneration and Error (Red), and 5 LEDs on the right showing Fuel level indication, Errors or Working Hours (see pict. 16).



### OPERATING INSTRUCTIONS

	<p><b>1)</b></p> <p>With engine off, check the absence of danger, connect Refuelling Nozzle to the vehicle fuelling receptacle and verify it is correctly connected by pulling it slightly to ensure it will not disconnect.</p>
	<p><b>2)</b></p> <p>Push the START button. The HRA will start working.</p>
	<p><b>3)</b></p> <p>If compressor has stopped automatically go to the next step; if you need to stop refuelling while in progress, press the STOP button.</p>
	<p><b>4)</b></p> <p>Disconnect refuelling hose from vehicle and return the refuelling nozzle to the nozzle holder.</p>

A HRA is equipped with diagnostic software constantly monitoring and controlling the unit's operation. Light indicators can show different conditions by pushing START and STOP buttons in a specific sequence.

**DISPLAY HRA WORKING HOURS**

Push STOP to reset panel, then keep START and STOP buttons pressed. Fuel level indicators lights will show unit working hours. See table below to identify hours code.

Da 0 a 249	Da 250 a 449	Da 500 a 749	Da 750 a 999	Da 1000 a 1249	Da 1250 a 1449	Da 1500 a 1749	Da 1750 a 1999
Da 2000 a 2249	Da 2250 a 2449	Da 2500 a 2749	Da 2750 a 2999	Da 3000 a 3249	Da 3250 a 3499	Da 3500 a 3749	Da 3750 a 3999
Da 4000 a 4249	Da 4250 a 4449	Da 4500 a 4749	Da 4750 a 4999	Da 5000 a 5249	Da 5250 a 5499	Da 5500 a 5749	Da 5750 a 6000

Tabella 4 -Working Hours codes

**DISPLAY ERRORS**

In the case of an error condition, the system stops HRA from working allowing the unit to be reset or locking out the system depending on the error condition. If the error can be reset, refuelling will restart by first pushing the STOP button to reset Panel and then the START one. In the case of an internal error or gas leak detection, the system will shut down and lock itself off. An authorized service technician will be required to service and reset the HRA.



**WARNING: If software blocks HRA, do not disconnect electrical supply as the unit will run when required exhaust fans and maintain gas sensors until service can be provided. Failure to do so may result in serious injury and/or death and/or property damage.**

When the Error Light is illuminated the User can press and hold the Stop button, With the Stop Button depressed the User's panel will display the last error code recorded. PC diagnostic software is available to display unit's current parameters and Errors Archive. See table below to identify error code and know the possible corrective action to carry out.



ERROR CODE	CORRECTIVE ACTION	ERROR CODE	CORRECTIVE ACTION
 <p><b>Low Inlet Pressure 00001</b></p>	<ul style="list-style-type: none"> <li>- Check the right inlet pressure</li> <li>- Check that inlet manual valve is open</li> <li>- Check the adequate diameter of supply pipe</li> <li>- Check reducer (if present).</li> </ul>	 <p><b>Engine Overvoltage 00101</b></p>	<ul style="list-style-type: none"> <li>- Check that voltage range is included between 216 V AC and 252 V AC</li> <li>- Check HRA right connection to the electrical supply line</li> </ul>
 <p><b>High pressure sensor alarm 00010</b></p>	<p>Disconnect electrical supply for 1 minute and connect it again.</p> <p>If anomaly persists, call technical support.</p>	 <p><b>Int. Gas Sensor Alarm 00110</b></p>	<ul style="list-style-type: none"> <li>- Check possible external cause: <ul style="list-style-type: none"> <li>- Refuelling fitting</li> <li>- Vehicle equipment</li> <li>- Refuelling pipe</li> <li>- Gas Inlet pipe</li> <li>- Material stored into refuelling area</li> </ul> </li> <li>- If no causes are found, close gas manually and call technical support.</li> </ul>
 <p><b>Overpressure 10111</b></p>	<p>Disconnect electrical supply for 1 minute and connect it again.</p> <p>If anomaly persists, call technical support.</p>	 <p><b>Ambient temperature out of range 01110</b></p>	<p>Ambient temperature out of range:</p> <ul style="list-style-type: none"> <li>- Tamb &lt;-45°/-49°F</li> <li>- Tamb &gt;55°C/131°F</li> </ul> <p>Temperature sensor malfunction</p>
 <p><b>Blow down over pressure 00011</b></p>	<p>Back pressure from the car tank. Stop the HRA, Re-START after 5-10 minutes.</p> <p>If the problem remains close the car tank valve and call the technical support.</p> <p>Do not use the car</p>	 <p><b>Insufficient pressure increasing 00111</b></p>	<p>Check possible leakages:</p> <ul style="list-style-type: none"> <li>- Safety Disconnection device</li> <li>- Refuelling fitting</li> <li>- Vehicle equipment and filling point.</li> </ul> <p>This error could occurs if the car tank is almost empty. Fill the tank partly.</p> <p>Re-START the HRA</p>

Tabella 5 - Errors Diagnostics

ERROR CODE	CORRECTIVE ACTION	ERROR CODE	CORRECTIVE ACTION
 <p><b>Motor overtemperature 00100</b></p>	<p>Check:</p> <ul style="list-style-type: none"> <li>- Supply voltage</li> <li>- Possible air inlets obstruction</li> <li>- Air discharge dimension, min.125mm/4.9", max. length 15mt/49ft with max. 3 changes of direction-Fan</li> </ul>	 <p><b>High pressure drop 01000</b></p>	<p>Check possible external cause:</p> <ul style="list-style-type: none"> <li>- Refuelling fitting</li> <li>- Vehicle equipment</li> <li>- Refuelling pipe</li> <li>- Gas Inlet pipe</li> </ul>
 <p><b>Combi-valve alarm 10110</b></p>	<p>Disconnect electrical supply for 1 minute and connect it again.</p> <p>If anomaly persists, call technical support.</p>	 <p><b>Bypass-valve malfunction 11000</b></p>	<p>Disconnect electrical supply for 1 minute and connect it again.</p> <p>If anomaly persists, call technical support.</p>
 <p><b>Dryer alarm 10000</b></p>	<p>Condenser or evaporator or heater Dryer malfunction.</p> <p>Call technical support.</p>	 <p><b>Dryer condenser temperature out of range 11001</b></p>	<p>Dryer condenser temperature out of range: &lt; -55°C/-67°F &gt;105°C/221°F</p> <p>Call technical support.</p>
 <p><b>Dryer evaporator temperature out of range 11010</b></p>	<p>Dryer evaporator temperature out of range: &lt; -55°C/-67°F &gt;105°C/221°F</p> <p>Call technical support.</p>	 <p><b>Peltier power adsorption 11011</b></p>	<ul style="list-style-type: none"> <li>- Disconnect electrical supply for 1 minute and connect it again.</li> </ul> <p>If anomaly persists, call technical support.</p>

**Table 5 - Errors Diagnostics (Continue)**

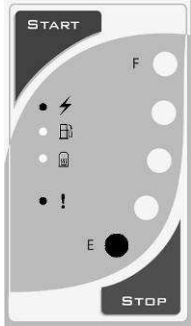
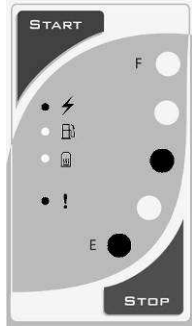
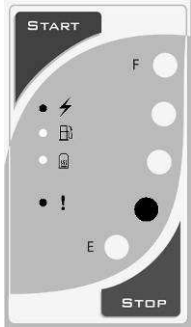
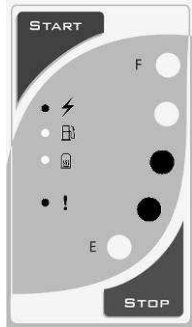
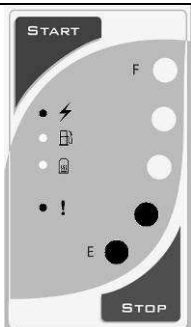
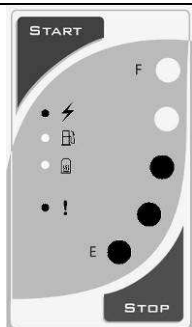
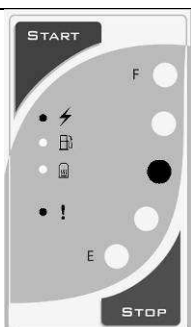
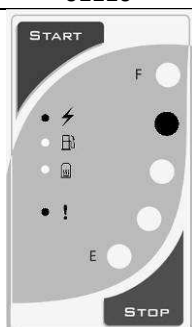
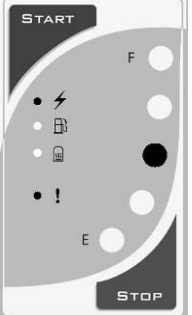
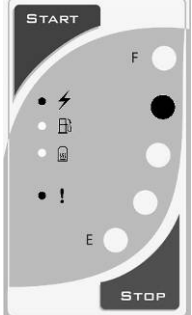
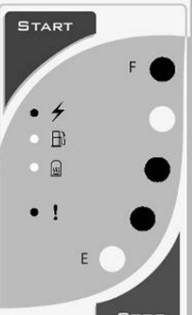
ERROR CODE	CORRECTIVE ACTION	ERROR CODE	CORRECTIVE ACTION
 <p><b>Inadequate Cooling Air Flow</b> <b>01001</b></p>	<p>Check:</p> <ul style="list-style-type: none"> <li>- Possible cooling air inlet obstructions</li> <li>- Air discharge dimension, min 125 mm max length 15 mt with max 3 changes of direction</li> <li>- Fan</li> <li>- Ensure operation of air flow switch checking for debris blocking movement</li> </ul>	 <p><b>Ext. Gas Sensor Alarm</b> <b>01101</b></p>	<p>- Check possible external cause:</p> <ul style="list-style-type: none"> <li>- Refuelling Nozzle</li> <li>- Vehicle equipment</li> <li>- Refuelling Hose</li> <li>- Gas Inlet pipe</li> <li>- Material stored into refuelling area</li> </ul> <p>Eliminate leakage source (close manual valve) and call authorized technical support.</p>
 <p><b>Max Refueling Time</b> <b>01010</b></p>	<ul style="list-style-type: none"> <li>- Check possible leakages:</li> <li>- Refuelling Nozzle</li> <li>- Vehicle equipment</li> <li>- Refuelling hose</li> </ul> <p>Restart HRA.</p>	 <p><b>Electrical error non-maintainable</b> <b>11111</b></p>	<p>Disconnect electrical supply for 1 minute and connect it again.</p> <p>If error condition persists, call technical support.</p>
 <p><b>High Inlet Pressure</b> <b>01011</b></p>	<p>Check conformity of gas supply line pressure to technical specifications.</p> <p>Check the pressure regulator (if present).</p>	 <p><b>Back-Pressure</b> <b>22222</b></p>	<p>Do not disconnect electrical supply. Do not force refueling fitting disconnection from vehicle.</p> <p>Try to stop and restart HRA every 5-10 minutes.</p> <p>If problem persists, close vehicle manual valve, call technical support.</p> <p><b>Do not use vehicle until error has been corrected.</b></p>
 <p><b>High Pressure Gas Leakage</b> <b>01100</b></p>	<p>Check possible obstructions or damages:</p> <ul style="list-style-type: none"> <li>- Safety Disconnection device</li> <li>- Refuelling fitting</li> <li>- Vehicle filling point</li> <li>- Refuelling pipe</li> </ul>	 <p><b>Start Button Error</b> <b>10001</b></p>	<p>Check:</p> <ul style="list-style-type: none"> <li>- Connections</li> <li>- Adapter board</li> <li>- Cables</li> </ul> <p>Try to stop and restart HRA.</p> <p>If problem persists, replace user's control panel.</p>

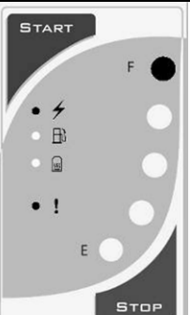
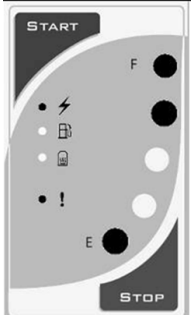
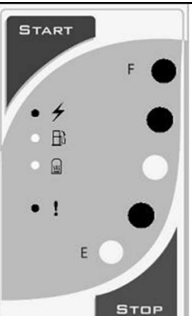
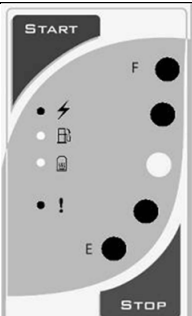
Table 5 - Errors Diagnostics (Continue)

ERROR CODE	CORRECTIVE ACTION	ERROR CODE	CORRECTIVE ACTION
 <p><b>Stop button error 10010</b></p>	<p>Check:</p> <ul style="list-style-type: none"> <li>- Connections</li> <li>- Adapter board</li> <li>- Cables</li> </ul> <p>Try to stop and restart HRA.</p> <p>If problem persists, replace user's control panel.</p>	 <p><b>Air flow error 01111</b></p>	<ul style="list-style-type: none"> <li>- Check possible cooling system obstruction</li> <li>- Check the free movement of flow meter blade</li> <li>- Check sensor supply voltage</li> <li>- Replace flow meter</li> </ul>
 <p><b>Internal gas sensor error 10011</b></p>	<ul style="list-style-type: none"> <li>- Check and clean internal gas sensor</li> <li>- Check connections</li> <li>- Check sensor supply voltage</li> <li>- Replace sensor</li> </ul>	 <p><b>Internal gas sensor calibration error 10100</b></p>	<ul style="list-style-type: none"> <li>- Check sensor supply voltage</li> <li>- Replace sensor</li> </ul>
 <p><b>TRIAC error 10101</b></p>	<p>Disconnect electrical supply for 1 minute and connect it again.</p> <p>If anomaly persists, call technical support.</p>	 <p><b>POWER OFF error 11110</b></p>	<p>Possible problem related to excessive jumps of line voltage.</p> <p>- If problem is not the line, Disconnect electrical supply for 1 minute and connect it again.</p>
 <p><b>Remote communication error 11101</b></p>	<ul style="list-style-type: none"> <li>- Possible failure due to the remote device.</li> <li>- Check the connection</li> <li>- If the problem is not connecting call for service</li> </ul>	 <p><b>Sudden pressure increase 11100</b></p>	<ul style="list-style-type: none"> <li>- Possible obstruction of the tube of high pressure in the event of a sudden pressure increase</li> <li>- Call technical support.</li> </ul>

**Table 5 - Errors Diagnostics(Continue)**

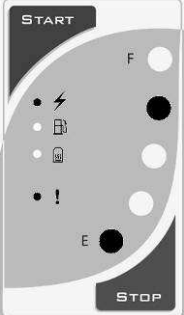
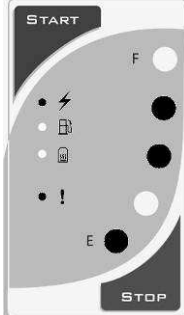
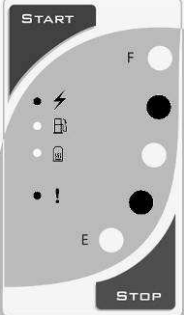
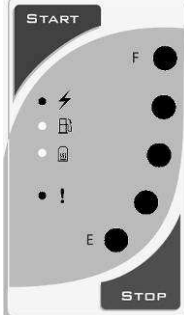
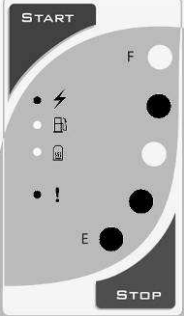
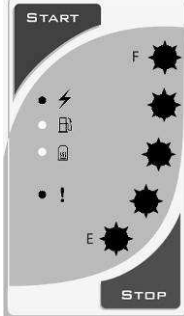
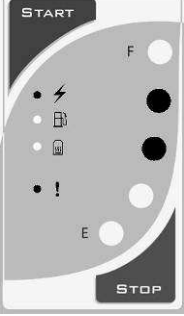
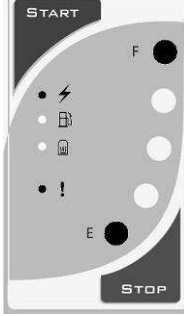
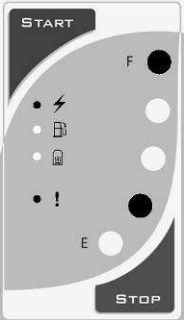
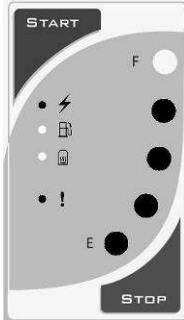
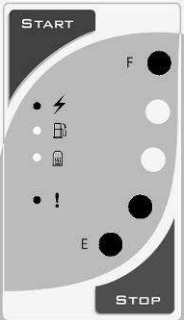
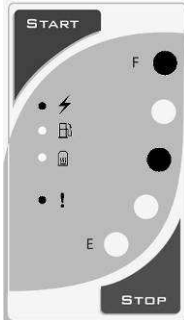
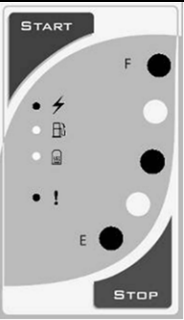
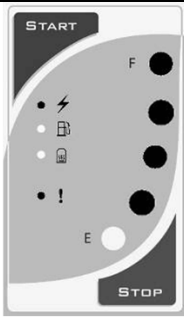
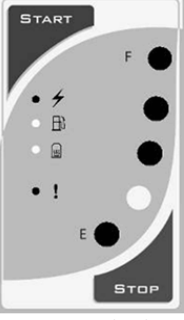
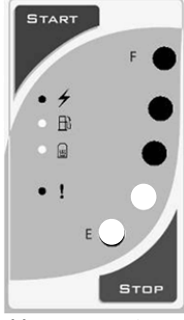

 <p>Calibration error</p>	<p>- Disconnect electrical supply for 1 minute and connect it again</p>	 <p>Software error</p>	<p>- Disconnect electrical supply for 1 minute and connect it again</p>
--	---	---	---

Table 5 - Errors Diagnostics(Continue)

Optional functions can be supplied exclusively by the manufacturer:

- **Empty Tank Function**  
 When the tank is completely empty this function allows to make a forced compression to create the necessary conditions for overcoming the error of **Insufficient pressure increasing 00111**.  
 The compressor is placed in standby condition recognizable through the blinking of both filling and error indicators. To activate this function press three times in three seconds the START button (in case of incorrect procedure the error **High Pressure Gas Leakage 01100** appears).  
 During the compression the filling indicator remains alight while the error indicator blinks.  
 At the end of the compression the leak test is performed. If the test is positive the error indicator switch-off and the HRA continues compressing. If the leak test is not passed the **High Pressure Gas Leakage 01100** appears and the HRA stop.  
 By pressing the STOP button the "Empty tank" function can be stopped and the **High Pressure Gas Leakage 01100** error appears.  
 During Empty tank (recognizable by the error indicator blinking) supervision is always recommended.
- **Final pressure compensation** function in reference to the ambient temperature. The maximum filling pressure varies according to the regulations in force in the country of installation. If this function is not required is possible to disable it.
- **Bypass regeneration function.** In case of Dryer error during the regeneration process the HRA stops this function but the filling goes on. If the by-pass regeneration function is active the Dryer indicator blinks. The bypass regeneration will stop if one dryer regeneration cycle is completed at least.
- **Evaporator function (Nafion) Membrane.** In case of ambient temperature lower than 5°C/41°F the membrane heater switch on in order to avoid damages due to ice formation. The heater shutdown if the ambient temperature reaches 7°C/44.6°F.
- **CMPDrying.** This function can be performed by the system before a regeneration in order to purge the moisture eventually accumulated in the compressor (a number of conditions such as: regeneration required, filling started from 4s, output pressure ≤ 400 psi have to be satisfy). This function is not possible whit HRA models not equipped with dryer.
- **Dryer, Internal gas sensor Air Flow Control.** These accessories can be avoided if required
- **Optional functions activated/deactivated by the dealer with the manufacturer permission only:**
  - External gas detector (provided by manufacturer).
  - Maximum filling time.
  - Filling pressure increasing check.
  - Maximum filling pressure reduction in reference to HRA working hours.
  - Time between regenerations.



## 7. MAINTENANCE INSTRUCTIONS

Users and unauthorized personnel should not access internal components for safety reasons; after installation, authorized personnel should close Cover applying the suitable seal provided with the handbook. HRA should only kept maintained by authorized personnel suitably trained.

Technical service should always:

- 1 Compare errors shown by HRA with table 4
- 2 Try to solve problem verifying installation or replacing components
- 3 Test HRA to verify if problems have been eliminated
- 4 Close and seal HRA



### **WARNING:**

Any other operation not described in this manual should only be carried out by BRC-FuelMaker at its premises. Any service completed by UNAUTHORIZED personnel will invalidate the warranty and may cause damage to the compressor, serious injury and/or death.

### **- Ordinary Maintenance Inspection**

Periodically check that the outlet pressure is correct (see table 2), verify that refuelling hose does not show abrasions, cutting or swelling; always contact an authorized service technician if damage to the hose is noted. Always check refuelling nozzle and the quick-disconnect breakaway device, contact an authorized service technician if damage is noted. Check that pressure relief and front/rear air inlets are free from material or ice.

**Any attempt to tamper with or open modules can cause damage, serious injury and/or death , and invalidate the warranty.**

## 8. HRA REMOVAL

If you need to remove the unit, follow these instructions:

- Check that Electric Supply button is OFF and gas inlet valve closed.
- Check the absence of voltage on electric supply cable and disconnect it.
- Disconnect Inlet and Discharge pipe from HRA verifying the absence of overpressures; close fittings.
- Pack HRA with its original packaging.

For further information, please feel free to contact Technical Service.

## 9. DISPOSAL

### RIGHT DISPOSAL

At the end of the HRA's life, it should be removed and disposed according to installation Country laws in force.

A suitable separate collection for the following recycle and environmental disposal helps to avoid possible negative effects on environment and health and favours re-use and/or recycle of HRA materials.



**DO NOT DISPOSE COMPRESSOR TOGETHER WITH DOMESTIC WASTE**



**PHILL CONTAINS MATERIAL ABSORBING MERCAPTAN FROM NATURAL GAS DURING REFUELING OPERATIONS**

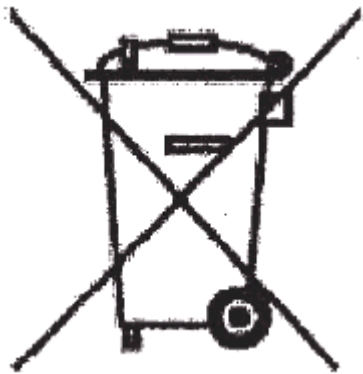

**Waste from Electrical and Electronic Equipment (WEEE)**  
**(Valid for European Union and other European Countries with waste separate collection systems)**



This symbol  on HRA, or on its documents means that product should be disposed at the end of its life according to directive 2002/96/CE about waste from Electrical and Electronic Equipment (WEEE) and implementation in national law.

HRA should not be disposed as urban waste but rather be delivered to the suitable collection point for electrical and electronic equipment.

Phill contains material absorbing mercaptan from natural gas during refueling operations. In case of wrong HRA disposal, you will be responsible for it in accordance with laws in force.

For further information about disposal and recycle of HRA please contact authorised offices or call your local **BRC FuelMaker Distributor**

## 10. WARRANTY CERTIFICATE

### WARRANTY CONDITIONS

M.T.M. Srl guarantees products for 24 months starting from the date of purchasing, within the limit of 2,000 working hours.

Purchasing should be proved by a fiscally valid receipt issued by the seller (fiscal ticket, invoice or transportation bill) identifying the product, the date of purchasing and/or delivery.

During the whole warranty period M.T.M. Srl engages itself to:

- (a) restore faulty products assuming all burdens of expenses concerning spare parts and transportation
- (b) replace faulty products not usefully repairable (e.g. when repair will cost more than replacement).

### GENERAL CONDITIONS

In order to benefit from warranty, the user will contact the seller and/or installer that will repair the machine having ascertained the working defect.

If seller and/or installer cannot solve the problem, the machine will be forwarded to BRC FuelMaker that will repair it or replace it with a new one at its own discretion.

The machine will be returned to BRC FuelMaker in its original packaging; lack of this packaging will automatically cause the warranty forfeiture.

Warranty will be acknowledged only if the purchasing receipt will be sent by fax or mail at the moment of the intervention request:

**BRC FuelMaker – Warranty Dept.**

**Fax: +39 0172.486.630**

**E.mail: Compressorservice@brc.it**

**This warranty will not cover:**

- a) Fair wear and tear
- b) Damages deliberately caused or due to negligence
- c) Damages caused by inobservance of working instruction or by a wrong installation
- d) Damages on non-functioning components that do not jeopardize the regular machine work, scratches and difference in colours included
- e) Accidental damages caused by foreign body or substance, especially included the non-standard composition of the gas supplied to the machine (gas quality).
- f) Repairs carried out by unauthorized assistance centres or repairs realized with non original spare parts
- g) Damages caused by transportation

# 11. CE CONFORMITY DECLARATION

BRC FuelMaker  
M.T.M. S.r.l.  
Via La Morra n°1  
12062 Cherasco (CN) \_ Italy



Tel. +39 017248681  
Fax. +39 0172593113

## CE DECLARATION OF CONFORMITY DICHIARAZIONE DI CONFORMITA' CE

Application of Council Directives: 2006/42/CE - Machinery Directive  
*Direttive comunitarie applicate* 2006/95/CE - Low Voltage Equipment  
2004/108/CE - The EMC Directive  
97/23/CE - PED Directive

Notified body charged of the conformity assessment:  
CSI S.p.A. – V.le Lombardia, 20 – 20021 BOLLATE (MI) – N.Id. 0497  
Terms of CE certificate according to B procedure: PED/0497/612/06  
Terms of CE certificate according to D procedure: PED/0497/613/06

Manufacturer's Name: MTM S.r.l. Società Unipersonale  
*Costruttore*  
Manufacturer's Address: Via La Morra n°1  
*Indirizzo del costruttore* 12062 Cherasco Cn, Italia

Equipment Type: Vehicle Refuelling Appliance  
*Tipologia apparecchiatura* *Apparecchio di erogazione ad uso privato di Gas Naturale per autotrazione.*

Trade Name Model No(s): HRA-P30-G1.5; HRA-P36-G1.5  
*Modello*  
Trade Mark: BRC FuelMaker  
*Marchio*

Standard(s) to which Conformity is Declared:  
*Normative applicabili a cui si dichiara la conformità:*

	Standard	Description
1	EN 60335-1:2002	Household and similar electrical appliances - Safety Part I: General requirements
2	UNI EN ISO 12100-1 UNI EN ISO 12100-2	List of Hazards assessment
3	E.S.R. (2006/42/CE)	List of Essential Health and Safety Requirements Applicable Standards for the Adopted Solutions
4	UNI EN ISO 14121: 2009	Safety of machinery – Principles for risk assessment
5	EN 60950-1 : 2001	Information Technology Equipment –Safety – Part I: General requirements
6	EN 60730-1	Automatic electrical controls for household and similar use. General requirements
7	EN 60730-2-9	Automatic electrical controls for household and similar use; Part.2: Particular requirements for temperature sensing controls
8	EN 61508	Functional safety of electrical / electronic / programmable electronic safety-related systems
9	UL 1998	Software in Programmable Components
10	NGV1/ISO 14469	Road Vehicle – Compressed Natural Gas Vehicle Refuelling Systems
11	NGV4.4/CSA 12.54 – 1999	Breakaway Devices for Natural Gas Dispensing Hoses and Systems
12	NGV4.2/CSA 12.52 -1999	Hoses for Natural Gas Vehicles and Dispensing Systems
13	PrEN 13945	Draft European standard for NGV refuelling appliances - at polling stage
14	CSA 12.6 - 04	Vehicle Refuelling Appliances
15	AGA 2-90	Natural Gas Vehicle Fueling Appliances
16	APG GNV1	Domestic Filling Equipment for Vehicles Running on Natural Gas
17	NFPA-52: 2006	Compressed Natural Gas (CNG) Vehicular Fuel System Code
18	AG806 - 1992	Approval Requirements for Vehicle Refuelling Appliances
19	C22.2 No. 182.3 – M1987	Special Use Attachment Plugs, Receptacles, and Connectors.
20	C22.2 No. 14-95 (R2000)	Industrial Control Equipment
21	C22.2 No. 77-95 (R2000)	Motors With Inherent Overheating Protection
22	UL Std No. 508	Safety requirements for Industrial Control Equipment
23	UL Std No. 508C	Safety Power Conversion Equipment
24	C22.2 No.236-M2005	Heating and Cooling Equipment



BRC FuelMaker  
M.T.M. S.r.l.  
Via La Morra n°1  
12062 Cherasco (CN) \_ Italy



Tel. +39 017248681  
Fax. +39 0172593113

25	EN 55022:1998+A1:2000	Electromagnetic Immunity
26	EN 55014-1:2000	Discontinuous Test
27	EN 61000-6-1:2001	Generic Immunity standard for residential, Commercial and light-industrial environments
28	EN 61000-6-3:2001	Generic Emission standard for residential, Commercial and light-industrial environments
29	EN 61000-4-2	Electrostatic Discharge Test
30	EN 61000-4-3	Radiated RF Immunity Test
31	EN 61000-4-4	Electric Fast Transient Test
32	EN 61000-4-5	Fast Surge Test
33	EN 61000-4-6	Conducted Immunity Test
34	EN 61000-4-11	Voltage Dip and Interruptions
35	EN 61000-3-2	Harmonic
36	EN 61000-3-3: 1995, +A1: 2001	Flicker

We, hereby declare that the BRC FuelMaker Vehicle Refuelling Appliance conforms to the following directives:  
*Si dichiara inoltre che il VRA della BRC-FuelMaker soddisfa le seguenti normative:*

- Test Report EN 60335-1: Household and similar electrical appliances – Safety Part 1: General requirements
- Risk Assessment as per EN 1050 & List of Hazards as per ISO 12100 (EN292)
- Machinery Directive (2006/42/CE) – List of Essential Health and Safety Requirements Applicable Standards for the Adopted Solutions
- Machinery Directive (2006/42/CE) – Description of problem and solution
- CSA Test Report 159937-1799097, Project 1799097: Performance testing to cover HRA for residential indoor and outdoor installation and operation
- CSA Test Report 159937-1799099, Project 1799099: Evaluation of the – Controller Module with Integral Power Supply
- CSA Test Report 159937-1805736, Project 1875401: Evaluation of the of the Safety Control Software
- CSA Test Report 159937-1601190, Project 1898919: Evaluation of Cable Pass Through
- CSA Test Report 159937-1591887 , Project 1591887: Electromagnetic Compatibility of HRA for residential and commercial installation and operation.

Mariano Costamagna  
The Legal Representative  
Il Legale Rappresentante



**M.T.M. srl**  
*Società Unipersonale*  
**IL PRESIDENTE**  
Costamagna Mariano

Date 15/02/2011  
Data

# 12. CERTIFICATE SIL 1

## TEST CERTIFICATE

### CERTIFICATO DI PROVA

**REGISTRATION No.** : 827  
NUMERO DI REGISTRAZIONE

**PRODUCT** : HOME REFUELING APPLIANCE  
PRODOTTO

**APPLICANT** : M.T.M. S.r.l.  
RICHIEDENTE VIA LA MORRA 1 - 12062 CHERASCO CN

**MANUFACTURER** : M.T.M. S.r.l.  
CoSTRUTTORE

**TRADE MARK** : M.T.M.  
MARCA

**MODEL/TYPE REF.** : HRA 1.5  
MODELLO/RIF. DI TIPO

---

**TEST RESULTS**  
RISULTATO DELLE PROVE

A sample of above product was found to be in compliance with the  
 Technical specification(s) / standard(s) listed below.  
*Un campione del prodotto specificato è stato provato ed è risultato conforme alle  
 norme/specifiche tecniche qui sotto indicate*

---

**TEST DETAILS**  
DETTAGLI DELLE PROVE

TEST REPORTS REFERENCES NO. <small>RIFERIMENTO RAPPORTI DI PROVA</small>	TECHNICAL SPECIFICATIONS / STANDARDS <small>SPECIFICHE TECNICHE / NORME DI RIFERIMENTO</small>
50AL00032	<b>IEC 61508 : 2010</b> SIL 1 FOR ALL SAFETY FUNCTION

**Place and Date of issue** : Milan, 2012/09/27  
LUOGO E DATA DI EMISSIONE Milano,

  
**IMQ**

This Test Certificate is the result of testing a sample of the product submitted, in accordance with the provisions of the specified Technical Specifications/Standards. It does not imply any judgment on the production and it does not permit the use of a mark of conformity. Only full reproductions of this Certificate are allowed without written permission of IMQ.  
*Questo Certificato di Prova è il risultato delle prove effettuate sul campione di prodotto presentato, seguendo le prescrizioni della corrispondente norma/ specifica tecnica citata. Esso non implica un giudizio sulla produzione e non permette l'uso di un marchio di conformità. Solo la completa riproduzione del Certificato è permessa senza l'autorizzazione scritta dell'IMQ.*



IMQ S.p.A. Società a socio unico I-20138 Milano - Via Quintilano 43 - tel. 0250731(r.a.) - fax 0250991500 - info@imq.it - www.imq.it  
 Rea: MI 1595884 - Registro Imprese MI 12898410159 - C.F./P.I.: 12898410159 - Capitale sociale 4.000.000 euro.

