

User Manual

Series B Series BA

960003E
Rev. 2

BOLZONI
AURAMO 

Safety Instructions



WARNING !!!

Know the capacity and limitations of your machine. Do not overload the lift truck or the attachment. Please note that the rated capacity of the truck/attachment combination may be less than the capacity shown on the attachment nameplate. The lift truck manufacturer is responsible for calculating the rated capacity for the combination. See the lift truck nameplate.



WARNING !!!

Never stand on the forks or on the load



WARNING !!!

Never stand under a load or attachment.



WARNING !!!

Never stand in the attachment operating area or between the forks.

WARNING !!!

Limit driving with a raised load to the minimum. Never accelerate or brake powerfully with a raised load.

WARNING !!!

Handle only those products **which** the attachment has been designed for. It is unsafe to lift any other objects.

WARNING !!!

Do not risk the lift truck stability by sideshifting. Sideshift only when the load is lowered down or near its seat. Use extreme caution when handling off-centered loads.

WARNING !!!

Always check the operating condition of the attachment before use. Never use a defective or damaged attachment. Repairs may be done by authorized personnel only.

Contents

1. General	4
1.1 Notices	
1.2 Safety Instructions	
2. Introduction	5
2.1 Bolzoni Auramo B-Series and BA-Series	
2.2 Nameplate	
3. Installation Instructions	7
3.1 Lift Truck Requirements	
3.2 Handling and Storage	
3.3 Installation	
3.4 Hose Flush	
3.5 Connecting the Hoses	
3.6 Air Removal	
3.7 Checks Before Operating the Clamp	
4. User Instructions	16
4.1 General Instructions	
4.2 Bale Handling	
4.3 Roll Handling	
4.4 Tips for Safe Operation	
5. Periodic Maintenance	19
5.1 Daily Checks	
5.2 Inspection and Service	
5.3 Tightening the Bolts	
5.4 Lubricants	
6. Trouble Shooting	22
6.1 General	
6.2 Safety Warnings	
6.3 Hydraulic System: B-Series	
6.4 Hydraulic System: BA-Series	
6.5 Trouble Shooting	
7. Service and Repairs	29
7.1 General	
7.2 Notes on Service Actions	
7.3 Service Instructions	
8. Spare Parts	33
8.1 Spare Parts Book	
8.2 Spare Parts Orders	

1. General

This manual contains installation, maintenance and service instructions for standard Bolzoni Auramo B-Series and BA-Series clamp attachments.

Please read this manual carefully before using or servicing this equipment. In this way, you will ensure safe and error-free operation of the clamp attachment right from the start.

Make sure that you know how the clamp works before you attempt to use it.

Every country has its own safety regulations concerning lift trucks and lift truck attachments. It is the responsibility of the user to know and follow these regulations. If safety recommendations given in this manual should differ from your local regulations, you should always follow the local regulations.

1.1 Notices

You will find three different levels of notices in this manual:

WARNING !!! - These paragraphs contain information that will help you prevent injuries.

CAUTION !!! - These paragraphs contain information that will help you prevent damage to the equipment.

NOTE !!! These paragraphs contain information that will help you service the equipment.

1.2 Safety Instructions

Always check the operating condition of the clamp attachment before use. Never use a defective or damaged attachment.

Never stand under a load or clamp attachment.

Never stand in the clamp operating area or between the clamping surfaces.

Handle only those products which the clamp attachment has been designed for. It is unsafe to lift any other objects.

Know the capacity and limitations of your machine.

2. Introduction

2.1 Bolzoni Auramo B-Series and BA-Series

Bolzoni Auramo B- and BA-series clamp attachments and fork positioners have several different models, which can be used for various load-handling operations.

All models have the following properties in common:

- Parallel arm opening and closing movement.
- Built-in sideshift.
- Well-protected valve block and connection hoses behind the attachment body.
- Rugged design
- Strong body, with favorable lost-load center, maximizing the residual capacity of the truck.

B-Series clamps have an aluminum-profile frame with T-profile arm carriers.

BA-Series clamps have a steel-profile frame with T-profile arm carriers.

Clamp and fork arms are available for varying load-handling needs. Typical applications include pulp-bale handling, wastepaper bale handling, paper roll handling, pallet handling, drum handling, tine handling, and other similar applications. Please refer to Bolzoni Auramo product specifications for further information about handling possibilities.

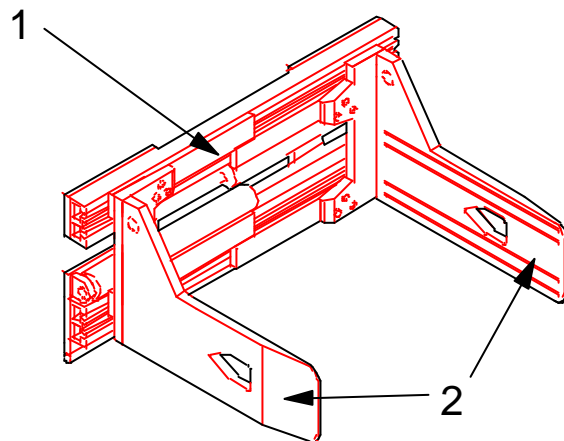
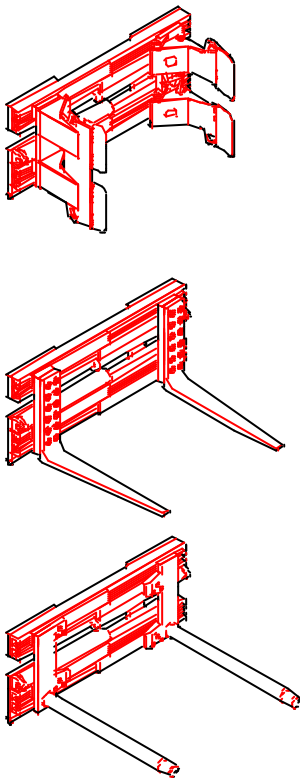

1. Clamp body
2. Clamp arms

Picture: Main components of a B/BA-Series clamp attachment

2.2 Nameplate

Every Bolzoni Auramo lift truck attachment has a unique serial number. This identification information can be found on the attachment nameplate, which is fastened to the clamp body.

Serial number and clamp attachment model must always be given when ordering spare parts or when making inquiries concerning the clamp.

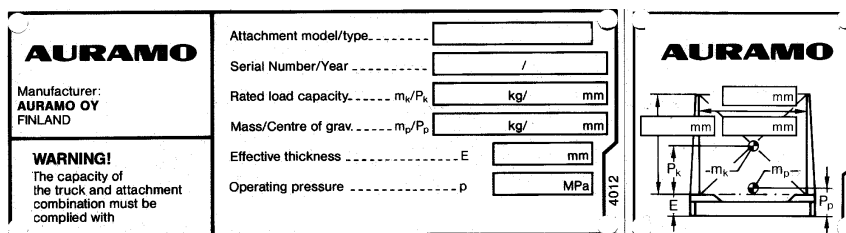

Figure: Nameplate

1. Attachment model
2. Serial number, production year
3. Rated load capacity (= allowed load in kg or lbs. at given load center)
4. Weight and center of gravity
5. Effective thickness
6. Maximum operating pressure
7. Opening range or roll range (max/min)

NOTE !!!

Damaged or lost nameplate should be replaced.

3. Installation Instructions

3.1 Lift Truck Requirements

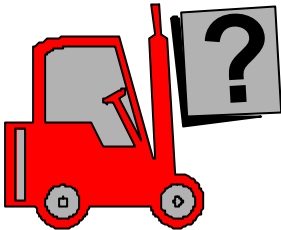

All lift truck capacity tables assume that the lift truck is operated with forks only. The rated capacity is given for a load with a center of gravity a particular distance from the vertical face of the forks. This distance is called the load center. Loads with a center of gravity further than this will reduce the lift truck rated capacity.

Attachments reduce the lift truck rated capacity. The lift truck capacity must be re-rated when an attachment is selected.

At the very least, the following factors should be taken into account when selecting the lift truck for the application:

- The effective thickness of the attachment pushes the load center forward.
- Attachment operation may further increase the load center. Example: Load extenders and tilting attachments.
- Attachment's own weight increases the lifted total load.

WARNING !!!

Never use the lift truck & attachment combination to lift more than its rated capacity, as stability factors will be changed. The lift truck may become unsafe.

3.1.1 Clamp Attachment Rated Capacity

Rated Capacity

The rated capacity given for each clamp is a nominal value defined by the clamp construction and clamping force. Rated capacity does not take into consideration properties of the load or working conditions.

Therefore, the net working capacity of a truck-clamp combination is not a fixed value. It is defined by the clamp rated capacity and the truck rated capacity at certain heights, loads and working conditions.

Net Capacity

The lift truck dealer or manufacturer must calculate the net working capacity for the lift truck-clamp combination.

WARNING !!!

Clamp attachment decreases the lift truck rated capacity.

WARNING !!!

The truck is dangerous to the driver and to persons working near the truck if the driver does not know the net working capacity.

Net capacity information must always be visible from the driver's seat.

WARNING !!!

The lift truck manufacturer is responsible for giving the final capacity rating to the forklift/attachment combination.

3.1.2 Hydraulic Pressure and Oil Flow Recommendations

Model	Recommended Oil Flow Rate l/min	Maximum Connection Pressure MPa	Maximum Clamping Pressure MPa	Hydraulic Functions
B-150-XX	25 — 40	16.0	16.0	2
B-200-XX	40 — 50	16.0	14.0	2
B-250-XX	40 — 50	16.0	16.0	2
B-320-XX	50 — 60	16.0	16.0	2
B-400-XX	50 — 60	16.0	16.0	2
BA-50-XX	60 — 80	16.0	16.0	2
BA-65-XX	60 — 80	16.0	16.0	2

Model	Recommended Oil Flow Rate gpm	Maximum Connection Pressure psi	Maximum Clamping Pressure psi	Hydraulic Functions
B-150-XX	6.6 — 10.6	2,320	2,320	2
B-200-XX	10.6 — 13.2	2,320	2,030	2
B-250-XX	10.6 — 13.2	2,320	2,320	2
B-320-XX	13.2 — 15.9	2,320	2,320	2
B-400-XX	13.2 — 15.9	2,320	2,320	2
BA-50-XX	15.9 — 21.2	2,320	2,320	2
BA-65-XX	15.9 — 21.2	2,320	2,320	2

Hydraulic pressure defines the operation force of the attachment. The attachment structure, cylinder seals, hoses and other hydraulic components define the maximum allowed hydraulic pressure.

If the lift truck produces more hydraulic pressure than what is allowed to any of the unprotected functions of the attachment, separate pressure relief valves must be installed into the lift truck or attachment hydraulic system.

WARNING !!!

Never exceed the maximum connection and operating pressures.

Oil flow to the attachment defines the operation speed of the attachment forks or arms. Generally it could be said that the higher the oil flow, the faster the forks or arms move.

However, there is a limit on how much oil can be forced through the lift truck and attachment hydraulic system. Too much oil flow may lead to:

- Excessive oil heating

- Decreased component lifetime
- Possible operation malfunctions

Too little oil flow also has its drawbacks as the following symptoms may occur:

- Slow operation
- Problems with simultaneous arm movement with multiple arm clamps
- Possible operation malfunctions

Normally the attachments operate well within a wide oil flow range. More than normal attention should be paid into the oil flow when selecting an attachment with multiple arm pairs or a very wide opening.

Note also that the hydraulic hoses going over the lift mast, hose reels, swivel blocks and hose connectors may throttle the oil flow to the attachment and affect the available operation speed.

3.1.3 Hydraulic Oils

Use petroleum-based hydraulic oil as recommended by the truck manufacturer.

If you wish to use aqueous-based or biohydraulic oils, please contact Bolzoni Auramo.

3.1.4 Hydraulic Functions

Standard Bolzoni Auramo B-Series and BA-Series clamps require two (2) hydraulic functions from the lift truck hydraulic system in order to enable clamping and sideshifting motions.

3.2 Handling and Storage of the Clamp Attachment

Prior to installation check the clamp carefully to ensure that no damage occurred during transportation.

3.2.1 Lifting the clamp

If you have to lift the clamp during installation, make sure that the capacity of your lifting device is adequate for the load.

WARNING !!!

Never go under a hanging load. Beware of load swing when lifting.

3.2.2 Long Period Storage

If, for any reason, the clamp has to be stored for an extended period, follow the instructions given below in order to prevent damage caused by corrosion:

- Clean the clamp carefully
- Lubricate and grease all parts that require lubrication (see Chapter 5 for instructions).
- Protect all parts that might corrode with a suitable corrosion inhibitor or grease.
- Move arms to a totally closed position (so that the piston rods are completely inside the cylinders).
- Protect the clamp from the effects of the weather. Store it inside or under a proper cover.
- Check the condition of the clamp during storage and, if possible, regularly run all hydraulic functions of the clamp several times.

3.3 Installation

Before installation carry out the following checks:

- Make sure that the lift truck fulfills all clamp requirements (Section 3.1).
- Check that the clamp mounting type is the same as the one used on the truck.
- Check that the lift truck hydraulic oil level is correct.
- Check that the lift truck auxiliary hosing and fittings are in good condition.
- Clean the fork carriage. Make sure that it has no defects or wear that could prevent the installation or use of the clamp attachment.

3.3.1 Installation, Standard Carriages

Installation to the most common standard fork carriages (types ISO 2328-2, 2328-3, 2328-4) is as follows:



- Remove the lower mounting hooks. With quick-change mounting models, open the lower mounting hooks.
- Lift the clamp to the carriage, so that it hangs from the upper mounting hooks.
- Center the clamp horizontally on the carriage.

- Install the lower mounting hooks. With quick-change models, close the lower mounting hooks.
- To prevent the clamp from moving on the carriage, two side locator blocks have to be welded to the upper carriage bar.
- Side locator blocks can also be welded to the upper mounting hooks, in which case the blocks must be positioned so that they are properly engaged in the mating notch on the truck carriage. In turn, centering the clamp might prove slightly more difficult. Welding instructions come supplied with the clamp.

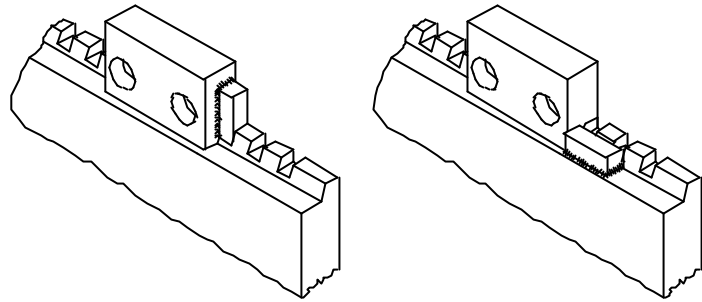
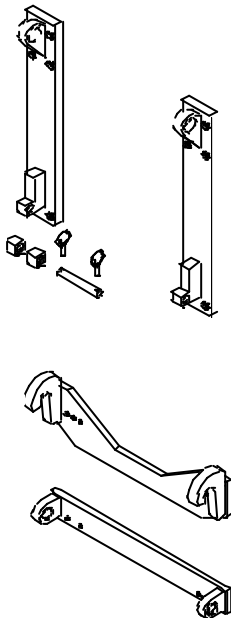

Figure: Positioning side locator blocks to the upper mounting hook or alternatively to the upper carriage bar.

WARNING !!!

Upper mounting hooks must be properly engaged on the upper carriage bar before fastening lower mounting hooks. If not properly engaged, the clamp can drop.

3.3.2 Installation of Special or Large Mountings



Pin type and hook type mountings, which are common in heavy-duty clamp models, are normally installed as follows:

- Remove lower pins.
- Hang the clamp to the truck carriage from upper hooks or pins.
- Center the clamp.
- Attach lower pins and fasten them properly.

WARNING !!!

Upper mounting hooks must be properly engaged on the upper carriage bar before fastening lower mounting hooks. If not properly engaged, the clamp might drop.

Instructions for special mountings can be found in the clamp spare parts book or in separate mounting instructions.

3.4 Hose Flush

Flush the truck mast hosing before you connect it to the clamp attachment. It is estimated that up to 80% of all defects in hydraulic systems are caused by dirty hydraulic oil. Oil from the mast hoses should be run through the oil filter during the flushing to minimize the amount of debris and dirt in the hoses.

- Connect each hose pair with suitable fittings. If needed, use an extra hose.
- Turn the truck on and actuate control valves in both directions for about 40 seconds.

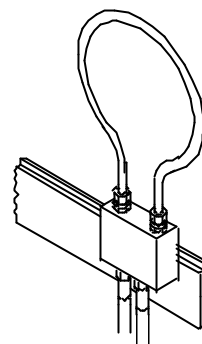

Figure: An example of a hose-flush connection

NOTE !!!

Hose flushing reduces the service costs in the long run!

3.5 Connecting the Hoses

Dimensions of the lift truck mast hoses and other hydraulic components must be adequate to meet the needs of a clamp attachment. In this way there is no excessive power loss or damage caused by oil overheating. Whenever possible, avoid 90-degree fittings as these cause large pressure loss.

For hydraulic connections, standard clamps have a connection block at the back of the clamp.

Standard connection fitting sizes: B- and BA-Series clamps

- B Series: European and international models, Ø 12 mm (M18x1,5 , 24°, DIN 2353)
- BA Series: European and international models, Ø 15 mm (M18x1,5, 24°, DIN 2353)
- US & Canadian models, JIC-8
- Special connection fittings are available on request.

Hose connections are located as follows (as seen from driver's seat):

- opening and closing of the arms on the right side
- sideshift on the left side

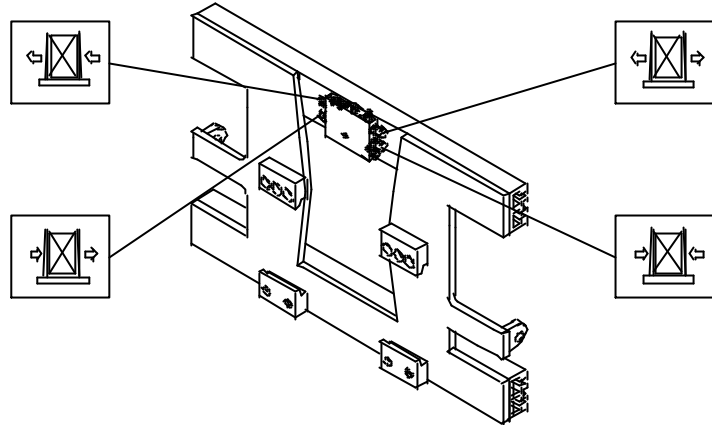

Figure: Hose connections of the B- and BA-Series clamp

- Attach connection hoses to fittings as shown in the figure. Make sure that hoses do not twist when tightening the fittings.
- Check that the hose lengths are correct. Check that the hoses are not pressed or chafed by any of the lift mast or attachment components.
- Do not use a smaller hose-bending radius than recommended by the hose manufacturer.

CAUTION !!!

Do not over-tighten hose fittings.

3.6 Air Removal

Air in the hydraulic system can cause extra flex or movements in clamp functions.

- Remove air by carrying out all movements (clamping and sideshift) several times between respective end positions.

WARNING !!!

Clamp arms can move unpredictably if there is air in the system.

3.7 Checks Before Operating the Clamp

Check the mounting and all functions of the clamp before using it for the first time.

3.7.1 Mounting and Clamp Mechanics

- Check all parts of the clamp to see that no damage occurred during the transportation.
- Check that there are no loose bolts or joints.
- Check that installation on the truck is correct.
- Check that the clamp is centered on the truck.

3.7.2 Hydraulic Parts

- Wipe clean all hydraulic parts.
- Check truck oil level.
- Run all movements (clamping and sideshift) several times between respective end positions.
- Check all cylinders, valves, hoses and fittings for any leaks.
- Check that hosing is correct also when pressurized.
- Check that arms move at the same speed, and if necessary adjust the speed (see 7.3.3 for instructions).

3.7.3 Clamping Force Test

It is recommended that regular clamping force tests are carried out in order to minimize the possibility of load damage. This is especially important with paper roll clamps and other clamps handling sensitive loads.

- Check clamping force by using the Bolzoni Auramo Test Pad, Test Stand, Test Cylinder or any other suitable device.
- Check that the clamping force is maintained when clamping for an extended time period. Leave the pressure on for 5-10 minutes and check for the loss of pressure. Clamping force may decrease up to 10% in ten minutes maximum.

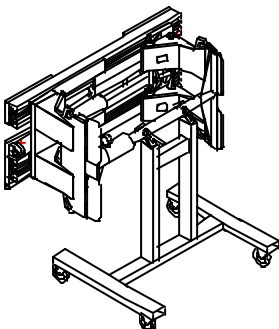

Figure: Bolzoni Auramo Test Cylinder for testing the clamping force

3.7.4 Action Test

- If possible test all clamp attachment functions with an actual load.
- Check that all movements also work when handling a load.
- Check the hydraulic system for any leaks or other problems.
- Check that the clamping force is correct for the load.

3.7.5 Operation Times

It is difficult to give exact values for clamping and sideshift times because the available pump flow volume affects movement speeds. Thus the values given below should be considered as guidelines only.

Clamping max-min	4-15 seconds, depending on the clamp size
Opening min-max	4-15 seconds, depending on the clamp size
Sideshift	4-15 seconds, depending on the clamp size

If measured operation times are much slower than given values, check all hydraulic system connections and the pump flow volume. If necessary, contact your Bolzoni Auramo representative.

4. User Instructions

This section gives some basic instructions on how to handle loads with different B- and BA-Series clamp attachment models.

4.1 General Instructions

Using the lift truck

Only trained and authorized operators may use the lift truck and the clamp attachment.

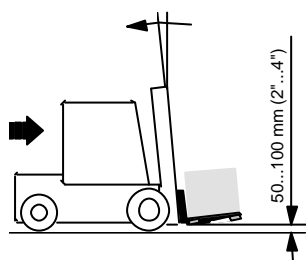

Driving with the load

Drive carefully and safely. Avoid strong acceleration and braking. Always drive with the load lowered down and, if possible, the mast tilted backwards. **No speeding! No overloading!** - consult the lift truck nameplate for available lifting capacity!

Parking

Always lower the load (and attachment) down when parking. Shut the power off and set the brakes on when leaving the truck unattended.

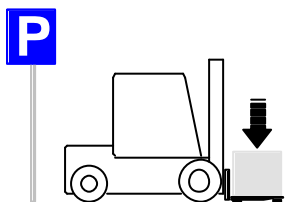

Loading

When taking a load or pallet from a stack, back away only so far as to be able to lower the load safely. Never accelerate or brake powerfully when the load is up, as this can lead to loss of balance.

Use extreme care when sideshifting or tilting raised loads.

Sideshifting

Do not risk the lift truck stability with sideshift. Sideshift only when the load is lowered down or near its seat. Use extreme caution when handling off-centered loads.

WARNING !!!

All B- and BA-Series clamps, with an internal sideshift, may be able to sideshift more than ± 100 mm (± 4 ").

The amount of available internal sideshift depends on the frame width and the arm opening. When the clamping arms or forks are in a totally open or closed position, there is no sideshift available.

4.2 Bale Handling

Pulp bales, wastepaper bales and other equivalent bales.

- Always grip bales or bale units in such a way that they are properly held between clamp arms.
- Do not push bale arms too deep - bales should not touch the clamp body.
- Do not clamp or lift bales with clamp arm tips only. Use the whole arm length to clamp the load.

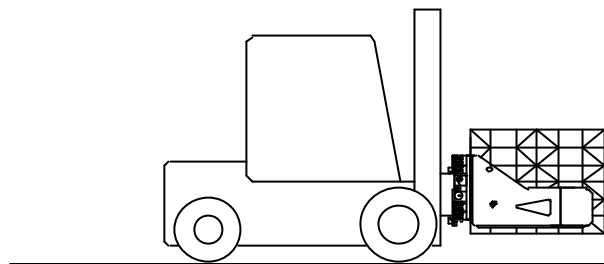

WARNING !!!

Always work safely.

Do not stand in the lift truck operating area or in front of the moving direction.

Never stand under a load or clamp attachment.

4.3 Paper Roll Handling

- Open arms only so far as to allow a roll to be clamped safely.
- Drive the truck into a position where the roll guides on the arms just touch the roll.
- Never drive the truck so near that the roll touches the arm carriers, because in such a position the roll can easily be damaged during the clamping operation.

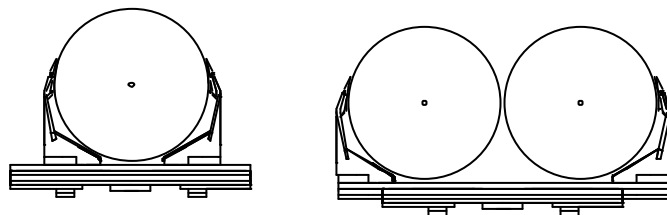

- Always grip the roll in such a way that the clamp attachment is aligned to the roll. Misalignment leads easily to roll damage. When handling single rolls or two parallel rolls, always grip the roll(s) so that the arms are centered between the ends of the roll.

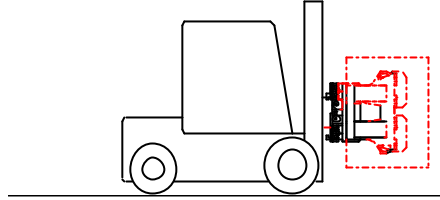

- Rolls must be side by side when clamping two parallel rolls. Otherwise rolls can slide on the floor during clamping thus causing roll end damage.
- When handling multiple rolls on top of each other, clamp attachments having split long arms are to be used. Grip the rolls in such a way that each roll is clamped by its own contact pad.

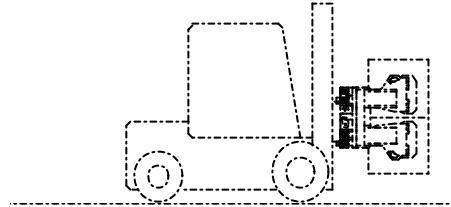
**WARNING !!!**

Always work safely.

Do not stand in the lift truck operating area or in front of the moving direction.

Never stand under a load or clamp attachment.

4.3 Tips for Safe Operation

- Clamp the load correctly.
- Drive carefully and safely. Avoid strong acceleration and braking.
- Always drive with the load lowered down and with the mast in a vertical or backward-tilt position. Note that too much tilt backward or forward increases the risk of roll or bale edge damage.
- When taking a load from the stack, back away only so far as to be able to lower the load safely. Never accelerate or brake powerfully when the load is up, as this can lead to loss of balance.
- Do not release the load before it is in place. Never let the load fall down.
- Beware of slackness in the mast chains.

5. Periodic Maintenance

5.1 Daily Checks

Check that there are no leaks, worn hoses or loosened parts in the clamp. Check the clamp frame and arms for defects or cracks.

Check that there are no sharp edges on such parts that come into contact with the load. Remove any such edges, for example, by grinding them.

Check all arms and contact pads and clean them if necessary. Contact pads (roll clamp models only) should move easily when tested by hand.

Check that the clamping force is correct for your load. Use an Bolzoni Auramo test cylinder if necessary. If needed, adjust clamping pressure to suit your needs. Never exceed a clamp's maximum operating pressure.

WARNING !!!

Always check the clamp operating condition before you use it. Never use a defective or damaged clamp.

Never exceed the maximum operating pressure.

5.2 Inspection and Service

WARNING !!!

In the following service actions the clamp is to be moved hydraulically. Do not leave any body parts between moving clamp attachment parts.

Do not remove pressurized parts.

Beware of part movements when removing hoses or pipes.

Do not climb on the clamp.

Carry out the following checks and services twice a year or every 300 hours, (whichever comes first).

- Clean the clamp
- Carry out all routine tasks mentioned in Section 5.1
- Open arms completely and apply an even layer of grease to the arm carriers and bearings. Open and close arms several times, and add grease wherever necessary.

- Protect all moving parts that are susceptible to rust (such as springs and pull rods). Apply grease to hinge pins (roll clamp models only). Be careful not to use too much grease or other lubricants, as these should not be allowed to touch roll or contact pads.
- Flush mast hoses, see Section 3.4 for instructions.
- Check the clamp for parts that might become defective or cause other trouble during the next service interval.
- Especially check arm carriers, hinge pins and their bushings.
- Roll clamps: Check contact pads, contact pad pull rods, contact pad springs and wear plates. Check also the arm pivot mechanism (split arm clamps only).
- Bale clamps: Check wear bars, check arm welds and mounting bolts.
- Fork clamps: Check the forks. Ensure that there are no visible cracks, especially in the fork heel area. Replace excessively worn, defective or damaged forks.
- Replace or repair all parts showing signs of excessive wear.
- Arm carriers, arm bearings and/or the clamp frame should be replaced if the play is such that it disturbs the normal use. Replacement is also necessary if arm movement is blocked or slowed down due to excessive wear or bending.

5.3 Tightening the Bolts

Most bolts on Bolzoni Auramo B- and BA-Series clamps are secured using LOCTITE 270. Bolts under high stresses are also tightened to a certain fastening torque. Normally retightening of the bolts is unnecessary.

Should loose bolts be found during daily checks, open them, apply some LOCTITE 270 to the bolt threads and retighten them. Also remember to check the tightness of bolts within the immediate area.

The following bolts are to have the specific fastening torque of:

Mounting Bolts				
Model	Bolt Size	Recommended fastening torque		
		Nm	kpm	lbs-ft
B-150-XX	M20	540 Nm	55 kpm	400 lbs-ft
B-200-XX	M20	540 Nm	55 kpm	400 lbs-ft
B-250-XX	M20	540 Nm	55 kpm	400 lbs-ft
B-320-XX	M20	540 Nm	55 kpm	400 lbs-ft
B-400-XX	M20	540 Nm	55 kpm	400 lbs-ft
BA-50-XX	M20	540 Nm	55 kpm	400 lbs-ft
BA-65-XX	M20	540 Nm	55 kpm	400 lbs-ft

Arm-fastening bolts				
Model	Bolt Size	Recommended fastening torque		
		Nm	kpm	lbs-ft
B-150-XX	M16	280 Nm	29 kpm	210 lbs-ft
B-200-XX	M16	280 Nm	29 kpm	210 lbs-ft
B-250-XX	M16	280 Nm	29 kpm	210 lbs-ft
B-320-XX	M16	280 Nm	29 kpm	210 lbs-ft
B-400-XX	M20	540 Nm	55 kpm	400 lbs-ft
BA-50-XX	M24	950 Nm	97 kpm	710 lbs-ft
BA-65-XX	M24	950 Nm	97 kpm	710 lbs-ft

Arm-girder (aluminum profile) bolts		Recommended fastening torque		
Model	Bolt Size	Nm	kpm	lbs-ft
B-150-XX	M16	190 Nm	19 kpm	140 lbs-ft
B-200-XX	M16	190 Nm	19 kpm	140 lbs-ft
B-250-XX	M16	190 Nm	19 kpm	140 lbs-ft
B-320-XX	M16	190 Nm	19 kpm	140 lbs-ft
B-400-XX	M16	190 Nm	19 kpm	140 lbs-ft

Cylinder fastening nuts		Recommended fastening torque		
Model	Nut Size	Nm	kpm	lbs-ft
B-150-XX		The clamping cylinder fastening nuts must be left relatively loose, as the the cylinder and piston rod must be able to move in relation to the clamp body.		
B-200-XX				
B-250-XX				
B-320-XX				
B-400-XX				
BA-50-XX		Grease the ball surfaces of the nut and its counterparts. Apply some LOCKTITE 270 glue onto the thread. Tighten the nut until it stops. Open the nut 1/4 to 1/2 rounds.		
BA-65-XX				

5.4 Lubricants (Greases)

The following lubricants are to be used on lubrication points on Bolzoni Auramo B- and BA-Series clamps:

Rounded sides of cylinder fastening nuts (clamping cylinders)

- Molyb Alloy MA412 (or equivalent)

All other lubrication points:

- Mobilplex 47 (or equivalent good quality grease)

6. Troubleshooting

6.1 General

It is estimated that up to 80% of all problems and defects in hydraulic systems originate from dirty hydraulic oils.

In most cases, dirty oil is the reason for various valve problems and excessive wear in seals and o-rings.

Because all clamp attachment hydraulic functions move back and forth, it is possible that the same debris might be moving in the oil for a very long time unless special attention is paid to cleanliness.

Bolzoni Auramo strongly recommends that the hydraulic oil and oil filters be changed regularly.

6.2 Safety Warnings

During all troubleshooting operations, work will be carried out near the clamp. Always work safely.

WARNING !!!

Do not open pressurized components.

Hydraulic components can be hot. Use suitable protection.

Beware of leaks. High-pressure oil can damage the eyes and skin. Always wear protection goggles having side-protection.

Do not remove cartridge valves when pressure is on.

Do not put your body parts between or near moving clamp parts.

Do not climb on the clamp.

6.3 Hydraulic System: B-Series

B-Series clamp attachments are manufactured with several different hydraulic options. In this manual you will find a description of our standard hydraulics. Standard hydraulics have a clamping function, a fast opening and a built-in sideshift (two hydraulic functions required).

Other possible hydraulic options are:

- Clamping hydraulics: Clamping and opening of the arms. One hydraulic function required. No sideshift.
- Independent hydraulics: Arms can be moved independently. Two hydraulic functions required. No sideshift.

6.3.1 Circuit Schematic, B-Series, Standard Hydraulics

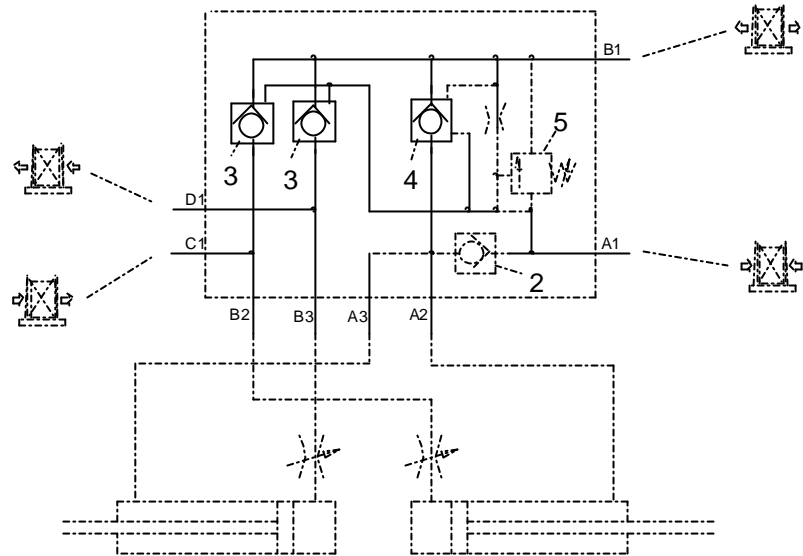

Figure: Circuit Schematic, Standard B-Series clamps

6.3.2 Hosing Diagram and Valves, B-Series

The figure below shows the hydraulic components of a standard B-Series clamp.

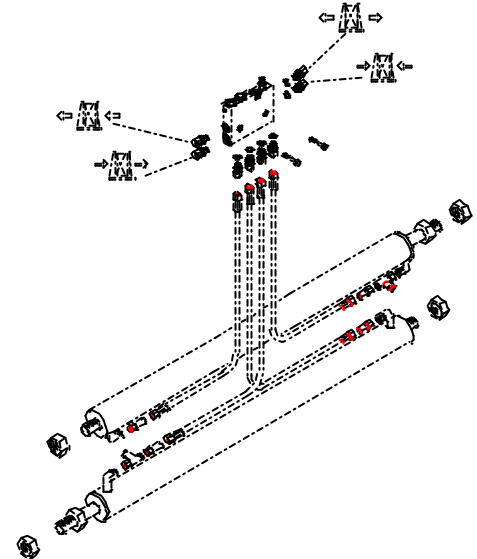

Figure: Hosing Diagram

Clamping Valve Block, B-Series

The clamping valve block controls all arm functions. In the figure below, the main components and functions of a clamping valve are indicated and described. Numbers in the figure correspond to those in the spare parts book.

- Check-valve cartridge (2): This valve holds the clamping pressure on.
- Check-valve cartridges (2 pcs.) (3): These valves enable sideshift motion.
- Check-valve cartridge (4): Controls the opening function.
- Main pressure-relief valve cartridge (5): This valve is used to control the clamping force of the clamp attachment.

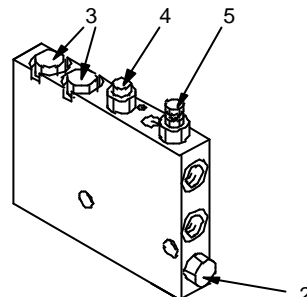

Figure: Clamping Valve Block

6.4 Hydraulic System: BA-Series

BA-Series clamp attachments are manufactured with several different hydraulic options. In this manual you will find a description of the standard hydraulic system. Standard hydraulics has a clamping function and a built-in sideshift (two hydraulic functions required). Other possible hydraulic options are:

- Clamping hydraulics: Clamping and opening of the arms. One hydraulic function required. No sideshift.
- Independent hydraulics: Arms can be moved independently. Two hydraulic functions required. No sideshift.

6.3.1 Circuit Schematic, BA-Series, Standard Hydraulics

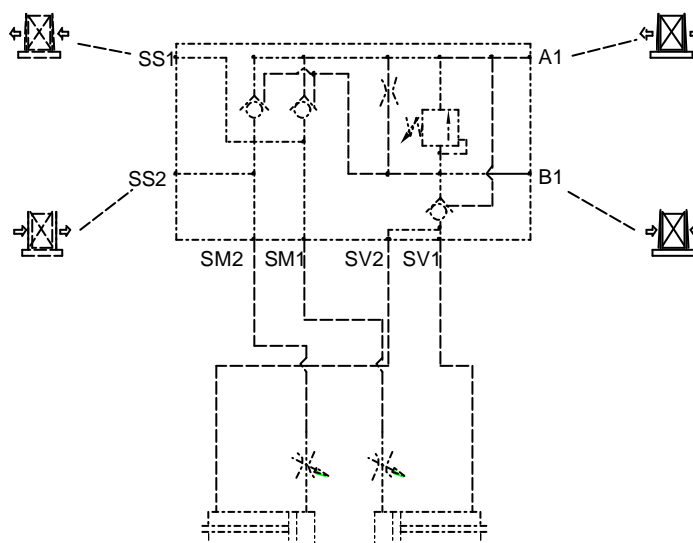

Figure: Circuit Schematic, Standard BA- Series clamps

6.3.2 Hosing Diagram and Valves, BA-Series

The figure below shows the hydraulic components of a standard BA Series clamp.

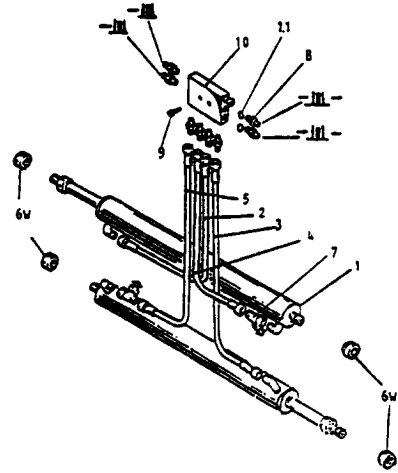

Figure: Hosing Diagram

Clamping Valve Block, Series BA

The clamping valve block controls all arm functions. In the figure below, the main components and functions of a clamping valve are indicated and described. Numbers in the figure correspond to those in the spare parts book.

- Main pressure-relief valve cartridge (1): This valve is used to control the clamping force of the clamp attachment.
- Check-valve cartridges (3 pcs.) (20): One check-valve (20P) keeps the clamping pressure and the other two enable the built-in sideshift function.

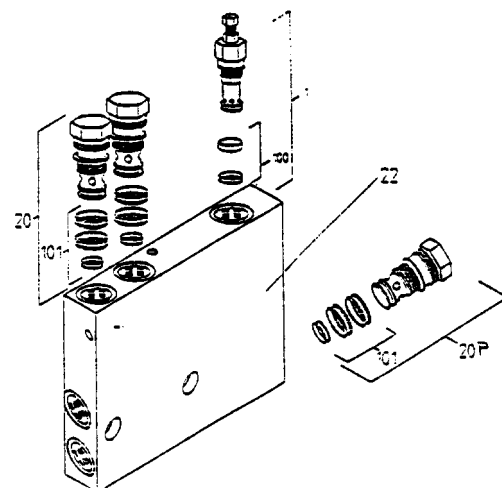

Figure: Clamping Valve Block

6.5 Trouble Shooting

Problem: No pressure in the clamp

Possible cause: Hose connection between the clamp and truck is defective

- Check all connections. If needed, replace them.

Possible cause: Failure in the truck hydraulic system

- Check that oil is coming from truck hydraulic system.

Problem: Pressure is on, arms do not move

Possible cause: Defective or worn arm carriers or arm carrier bearings

- Clean and repair or replace arm carrier bearings and/or arm carriers

Possible cause: Bent frame girders or clamp frame

- Check and straighten or replace damaged parts.

Possible cause: Incorrect hose connection

- Check the hoses. Rectify connections if needed.

Possible cause: Dirt in check valve

- Clean or replace check valves.

Possible cause: Pressure-relief valve defective or wrongly set

- Replace valve or correct the setting.

Possible cause: Leak in pressure cylinders

- Check and replace seals if needed.

Problem: Clamping force too small

Possible cause: Hydraulic pressure is too low

- Check truck pressure settings. Measure pressure coming from the truck. Pressure must be the same as, or higher than, what is required for the clamp.
- Check the oil level.
- Check for external leaks. If needed, clean components before examination.
- Blocked hose or fitting. Repair or replace.

Possible cause: Wrong setting in the main pressure-relief valve

- Check clamping pressure with the Bolzoni Auramo test cylinder. The pressure can be adjusted by turning the adjustment screw (clockwise - pressure increases, counterclockwise - pressure decreases). **Never exceed the maximum operating pressure of the clamp !**

Possible cause: Leak in check valve

- Clean or replace check valves or short arm pressure-relief valve.

Possible cause: Leak in cylinder seals

- Replace seals.

Possible cause: Too much pressure in tank line

- Check hoses and repair if needed.

Possible cause: Dirty arm carriers or arm-carrier bearings

- Clean and lubricate arm carriers and bearings.

Possible cause: Defective or worn arm carriers or arm-carrier bearings

- Clean and repair or replace arm carrier bearings and/or arm carriers

Problem: Clamping force OK, load falls

Possible cause: Worn friction surfaces

- Replace contact pads or friction surfaces.

Possible cause: Damaged arms

- Check the tightness of all arm fastening bolts. Check the condition of the arms. Repair or replace arms.

Possible cause: Operator error

- Check that the load is clamped correctly and that there is no overloading.

Possible cause: Wrong clamp for the load

- Check if clamp capacity, arm opening range and arm models are suitable for the load.

Problem: Loss of clamping force

Possible cause: Leaks in hoses or fittings

- Check for external leaks. If needed, clean components before check.

Possible cause: Leak in check valve

- Clean or replace check valves.

Possible cause: Leak in cylinder seals

- Replace seals.

Problem: Clamp arms close or open too slowly

Possible cause: Oil flow from the pump is too small or much too high

- Check the pump and replace/repair it if needed. Note flow rate recommendation (see Section 3.1.3).

Possible cause: Defect in hoses or hoses are too small

- Repair or replace with correct sizes.

Possible cause: Restrictor valves in the cylinders have wrong setting.

- Adjust valves.

Problem: Arms move roughly

Possible cause: Air in the system

- Remove air by totally opening and closing arms several times.

Possible cause: Dirt in hydraulic system

- Clean system and change oil and oil filter.

Problem: Arms do not move at the same speed

Possible cause: Dirt between arms and body or uneven wear

- Clean the clamp. If this proves ineffective, adjust restrictor valves from cylinders (see Section 7.3).

Problem: Built-in sideshift does not work

Possible cause: Arms are either too open or too closed

- The built-in sideshift function is carried out using the same cylinders as the clamping function. Thus, possible sideshift movement depends on the position of the arms. When the arms are totally open or totally closed, there is no available sideshift. Maximum sideshift is available when the arms are in the middle of their movement range.

Possible cause: Leak in check valve

- Clean or replace check valves.

7. Service and Repairs

7.1 General

Bolzoni Auramo Oy and its authorized representatives are anxious to answer all customer questions concerning Bolzoni Auramo service and products.

To help us resolve any problem you may be having as fast and accurately as possible, please check the following information before contacting us:

Clamp attachment type, serial number and production year. This information can be found on the clamp nameplate.

How and under which operating conditions the trouble occurs.

Type of operation, estimated work hours of the clamp.

Any other information you think will help us to help you.

7.2 Notes on Service Actions

Clean the clamp carefully before removing or replacing any parts.

Protect the environment. Always put used oil into a proper tank.

Do not let dirt or debris enter into the hydraulic system. Always protect open fittings with a proper cap. Clean all parts carefully before installing them onto the clamp.

7.3 Service Instructions

In the following pages you will find instructions on how to perform such service actions and repairs that are outside the normal maintenance schedule.

WARNING !!!

Read instructions carefully before you do anything. Repairs done incorrectly are safety hazards.

Follow all safety instructions given in previous chapters.

7.3.1 Hose Change

- Clean the clamp carefully before removing or replacing any parts.
- If the hose leaks from the fitting, first try to tighten the fitting. Change the hose only if this does not help.
- Label all hoses before removing them. This makes re-assembly significantly easier.
- Protect all open fittings with a proper cap.
- Make sure that hose length is correct before installing it. Always compare the length of new and old hoses.
- Make sure that enough play length is left on the hose before fastening.
- Do not over-tighten hose fittings. Over-tightening will easily cause damage to valve blocks or fittings. Make sure that hoses do not twist when tightening the fittings.

WARNING !!!

Never remove or tighten pressurized parts or hoses.

7.3.2 Seal Change, Clamp Cylinders

- Remove hoses, protect open fittings with proper caps.

WARNING !!!

Never remove pressurized parts or hoses.

- Open the housing (51).
- Pull the piston assembly and housing (20, 51, 50) out of the cylinder shell (10).

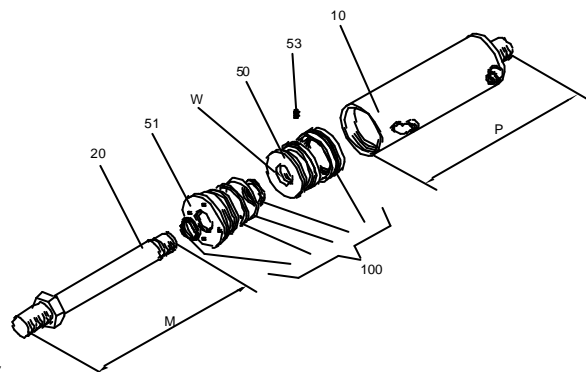

Figure: Clamp Cylinder

- Use a blunt screwdriver to take old seals away from the piston. If necessary cut the seals to remove them.

CAUTION !!!

Do not scratch piston surfaces with sharp tools.

Note the direction of the seals.

- Open the grub screw (53). If necessary, heat the screw before opening.
- Unscrew the piston (50) from the piston rod (20).
- Slide the housing (51) off the piston end of the rod.
- Remove old seals from housing.

CAUTION !!!

Do not scratch housing surfaces with sharp tools.

Note the direction of the seals.

- Clean and check piston, piston rod, cylinder shell and housing. See if there are any scratches, wear, corrosion, cracks or other similar defects that could prevent normal operation of the cylinder.
- Replace all damaged or worn parts.
- Install new seals to the housing.
- Lubricate seals and piston rod.
- Slide housing onto the rod from the piston end of the rod.
- Install the piston back onto the piston rod. Use LOCTITE 542 to secure the joint.
- Screw the grub screw back into the piston. Use LOCTITE 270 to lock the screw.

- Install new seals on the piston.
- Oil the cylinder shell.
- Slide piston assembly into the cylinder shell.
- Screw the housing into the cylinder shell.

- If possible, test run the cylinder before re-assembling it to the clamp. Max. test pressure is 22 MPa (220 bar, 3,200 psi).

- Re-install the cylinder to the clamp.
- Connect hoses.
- Test run all cylinder functions. Check for leaks.

7.3.3 Arm Synchronization

B-Series and BA-Series clamps have restrictor valves in arm cylinders. These valves enable arm-movement synchronization.

Restrictor valves have been adjusted at our factory but due to operating conditions or wear it is possible that the arms may begin to move at different speeds. In this case, you have to re-adjust the valves.

- Fully open the adjustment screws of both restrictor valves.
- Test the arm speeds at normal running power.
- Slightly tighten the adjustment screw of the faster arm. Test the speed again. Continue adjusting until both arms move at the same speed.

7.3.4 Replacement of Wear Bars

Bale clamps have welded wear bars underneath the arms. These bars are made of special wear resistant steel.

The purpose of these bars is to protect the arms from wearing during normal bale-handling operations.

Bars should be replaced before they become totally worn out.

- Remove the remnants of an old bar by, for example, grinding. Weld a new bar at the same location.
- Check also if there is excessive wear to other parts of the clamp and repair if necessary.

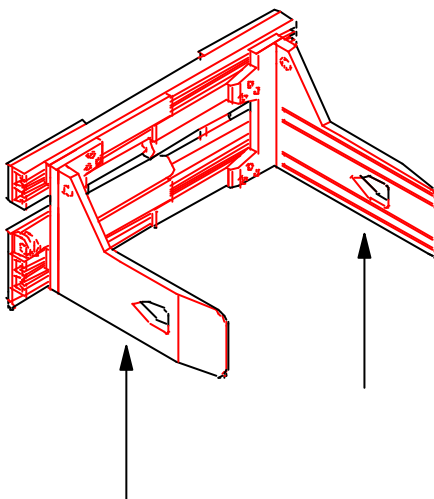

Figure: Location of wear bars

8. Spare Parts

Bolzoni Auramo and its authorized dealers supply spare parts for all products manufactured by Bolzoni Auramo.

8.1 Spare Parts Book

A unique Spare Parts Book comes with each clamp attachment. This book consists of four main parts:

Machine Card

Includes attachment definitions as mentioned in the order. The Machine Card also contains the same information as the attachment nameplate.

Construction List

The Construction is a list of the main parts of the clamp attachment. It contains part numbers for sub-construction spare parts.

Spare Parts List

Contains part numbers and part quantities in sub-constructions.

Some parts contain other parts (for example clamp cylinders and valves) and have their own spare parts lists. These lists are referenced in the sub-construction spare parts list.

Make sure that correct part numbers are quoted, especially where a part number is dependent on part dimensions or pressure used in the system (such as clamp cylinders and valves).

Quality Control Report

Includes results from tests and inspections carried out during the final check.

8.2 Ordering Spare Parts

In order to ensure a fast and error-free ordering of spare parts, always include at least the following data with your order:

- Name
- Delivery address
- Possible order number

- Clamp type and serial number
- Spare parts number
- Quantity
- Delivery type

Unless otherwise specified in the order, Bolzoni Auramo will deliver spare parts in such a way as it finds suitable.

NOTE !!!

Spare Parts Books are unique for each clamp attachment. Always use the correct book when ordering spare parts.

Make sure that the serial number in the Spare Parts Book is the same as the one on the attachment nameplate.

