

CO2 Transmitter/ Controller

Model #: AT-VLB-02-PID-NL-M1

User Manual



Specifications

Power supply	24VAC (50/60HZ±10%), 24VDC
Consumption	1.6 W max.
Gas sensor	Carbon Dioxide : Non-Dispersive Infrared Detector (NDIR) ABC Logic Self Calibration (default: effective)
CO ₂ measuring range	0~2,000ppm
Accuracy@25°C(77°F),2000ppm	±40ppm +3% reading
Stability	<2% of FS over life of sensor
Non linearity	<1% of FS
Response time	<2 minutes for 90% step change
Warm up time for each turning-on	<5minutes (operational)
1x analog output	0~10VDC(default), other voltage output type selectable by jumper J1 Linear or PID output type selectable by jumper J3 See 'Analog Output Type Selection' for details
Storage conditions	-10~70°C (-40~158°F) /0~95%RH, non condensing
Operation conditions	0~50°C (32~122°F); 0~95%RH, non condensing
Net weight/ Dimensions	110g/102mm×90mm×40mm
Installment standard	65mm×65mm(2"×4") wire box, or hang on a nail
Version	V. E072

Mounting and Wire Connection

- ◆ Notice the supply power voltage of the monitor: 24VAC. Do not install the monitor on voltages higher than marked on the monitor.
- ◆ Follows the step 1to step 4 in figure1 to remove the cover. Please note use your nails or other unship tools to depress the both clips which are on the sides of the monitor. Mount the monitor on the place where you want to detect CO₂ level. Do not mount it near diffuser or any steam source, in direct sunlight.
- ◆ Mount the wall plate first, there are two dimensions available (see figure 2). Place the monitor against the wall at desired location; make sure wires can be passed through the holes on the wall plate.
- ◆ Connect wires to terminal strips, (see figure 3). Make sure wiring connection correct and secure. Follows the step 5 to step 7 in figure 4 to close the cover.



Figure.1 Open it

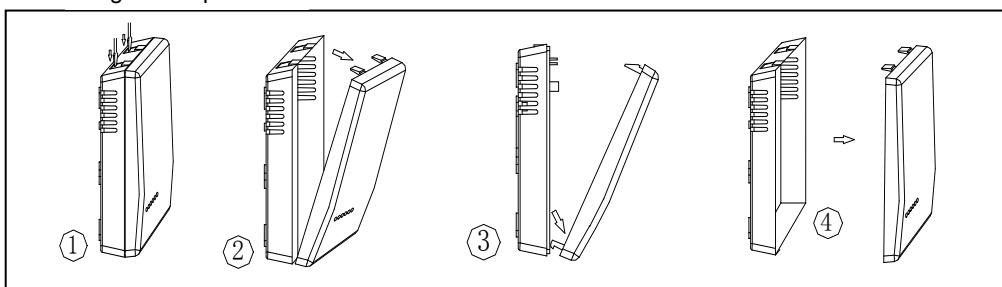

Figure.2 wall plate

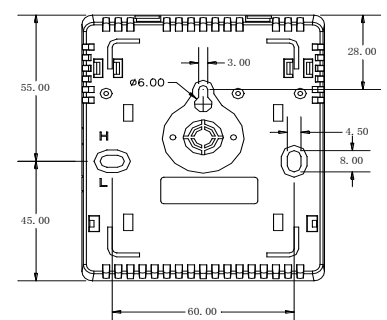

Figure.3 wiring diagram

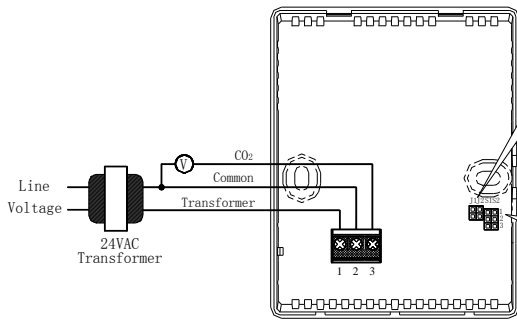
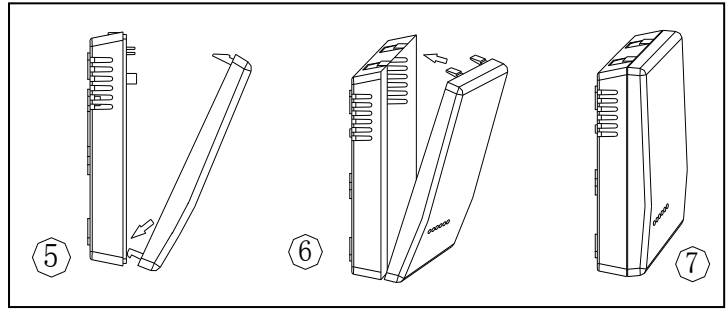

Figure.4 close it



Output and jumper selection

Connection Terminal	Function	Electrical Data
1	G+	Power(+)
2	G0	Power ground (-)
3	OUT	Analog output (+) selectable
		0~10VDC = 0~2,000ppm CO2 (default)

Analog Output Type Selection

Power off and open the front cover. You may see a group of jumpers at the bottom right of the PCB board.

First, set jumper S2 and S3 to be voltage output state (both with the 2nd and 3rd pin connected).

Then select voltage output type via jumper J1:

J1	voltage output
connection	10VDC
disconnection	0~10VDC (default)

Then select voltage output type between linear output and PID output via jumper J3:

J3	Voltage output type
connection	Linear output
disconnection	PID output (default)

Use jumper J4 & J5 to select CO2 set point for PID output:

J4	J5	CO2 set point for PID output
disconnection	disconnection	600ppm
connection	disconnection	800ppm
disconnection	connection	1000ppm (default)
connection	connection	1200ppm

Important Instructions:

1. Don't shake or hit the monitor too much in shipment or in mounting to protect the internal infrared CO2 sensor from any damage and excursion of infrared receiver.
2. When First use CO2 monitor, or Reuse CO2 monitor after a long time in stock, Keep the CO2 monitor energized continuously for at least 2 days to let CO2 sensor's ABC Logic™ self-calibration system operate properly. If it's measurement is still incorrect, then let its ABC Logic™ Self Calibration System work as follows: During a 14-day period, place the CO2 monitor twice in outdoors or unoccupied places where CO2 level is around 400ppm. Each time let it being there for more than 4 hours. If the CO2 measurement is in its accuracy limit, it indicates the measurement right.

Notice: Use of cellular telephones or radio transceivers with two feet of the sensor during calibration process could cause sensor interference, calibration errors and affect sensor accuracy. Please refrain from using these devices during sensor calibration.