



ONE SYSTEMS®

PORTABLE OUTDOOR POWERED SYSTEM 15a

POPS15a USER MANUAL



The exclamation point within an equilateral triangle is intended to alert the user to the presence of important operation and maintenance instructions.



High voltage:

The lightening flash with arrowhead symbol within an equilateral triangle is intended to alert the user to the presence of uninsulated “dangerous voltage” within the product’s enclosure that may be of sufficient magnitude to constitute a risk of electric shock to persons.



NOTE: The POPS 15a uses an auto-detection circuit that senses and adjusts internal operating voltages to the AC Mains supply. The POPS 15a will operate between 104VAC and 253VAC.

Although the AC Mains is automatically selected the user must insure that the proper AC Mains cable is supplied (GFCI enabled for 115VAC operation and PRCD enabled for 230VAC operation)



The Portable Outdoor Powered System 15a (**POPS15a**) was designed by One Systems to fulfill a unique need in the professional audio marketplace. The **POPS15a** was designed for use in any direct-weather outdoor applications, such as sporting events, theme park events, civic celebrations and general outdoor presentations. The **POPS15a** was designed for ALL weather applications and all its components were developed for use in rain, snow and other inclement weather applications. The highly-portable design is also ideal for mobile applications in gymnasiums, indoor and outdoor swimming pools and meeting rooms. The unique “narrow profile” integrated woofer and enclosure design provide superior acoustic output with excellent sight-line characteristics.

Specifications

Frequency Response:	50 Hz – 18,000 Hz
Coverage Pattern:	60° H X 40° V
Input / Thru:	3-Pin XLR-type (IP 67) (Pin 2 +)
Power	
Peak - Total System:	2,000 Watts
Continuous- Total System:	1,000 Watts
Peak Low Frequency:	1,000 Watts
Peak High Frequency:	1,000 Watts
Continuous Low Frequency:	500 Watts
Continuous High Frequency:	500 Watts
AC Mains Power:	104 VAC – 253 VAC (50 Hz – 60 Hz)
Max Acoustic Output (Peak):	130 dB*

Weather Performance:

IEC 529 / IP 56

Rigging:

M10 Stainless Steel (7 Points)

Supplied Accessories:

AC Mains Cable (100 Ft - 30.5 m)
Input / Output XLR-XLR (100 Ft - 30.5 m)
(Both Cables Supplied on Cable Reels)

Dimensions (H X W X D):

742 X 370 X 434 mm
29.2 X 14.6 X 17.1 inches

Weight

29 kg (64 lbs)

Operating temperature

0C – 40C (32F – 104F)

Available Accessories

POPS Sub a
M10 eyebolt kit

* NOTE: Actual measured response using a calibrated SPL meter with peak responding meter. Stimulus was a 1/3 octave band of pink noise with a 1 second duration.

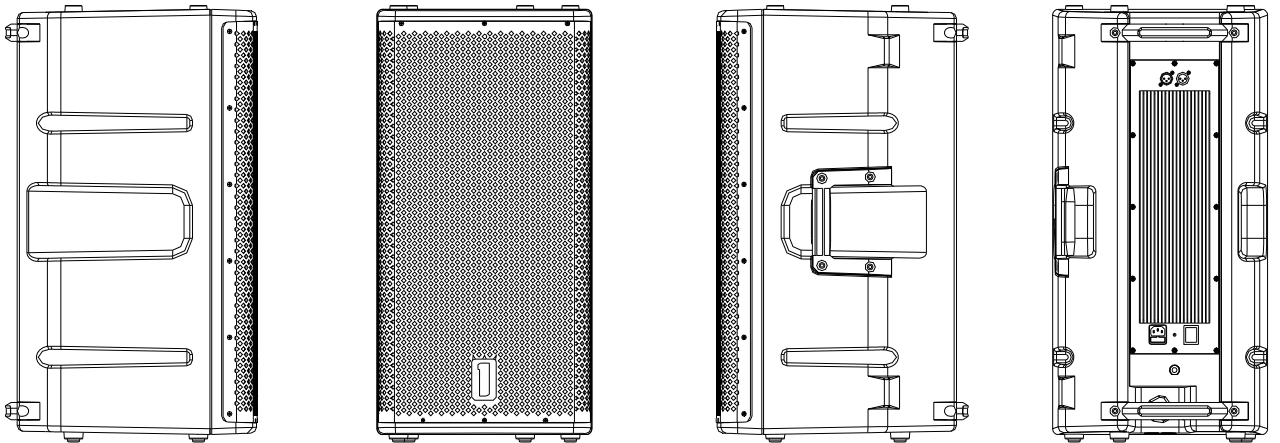

The image below shows **POPS15a** mounted on **POPSSub a** using the pole supplied with the **POPSSub a**.

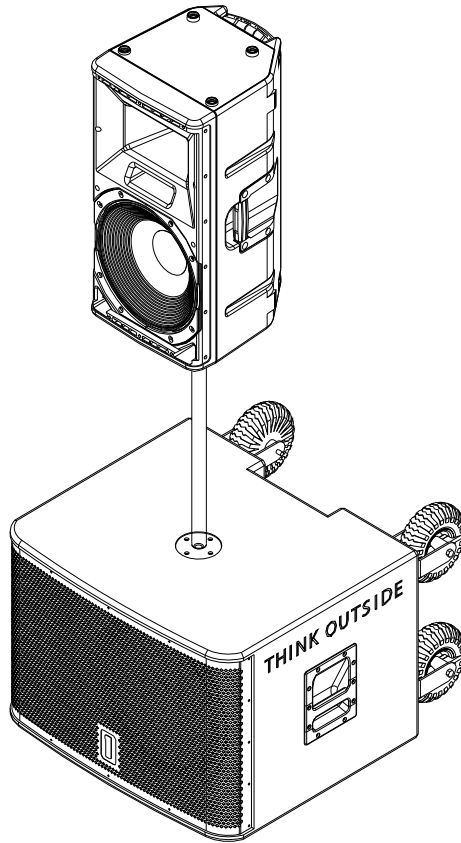

Read all of the instructions included in this manual



NOTE: The AC mains supply end of the **POPS15a** power cable **MUST** be plugged into a supply source that has a GROUND FAULT CIRCUIT INTERRUPTER (GFCI). The 115 V version is supplied with an in-line GFCI. The 230 Vac version is supplied with a Portable Residual Current Device (PRCD). In Europe, these devices are also referred to as Residual Current Devices or Residual Current Circuit Breakers.

NOTE: THE RESET ON THIS DEVICE SHOULD BE TESTED TO VERIFY PROPER OPERATION OF THE SAFETY DEVICE!

POPS15a is supplied with an “in line” GFCI device for use in countries that use 115VAC. **DO NOT** bypass this device or disable. The end of the AC Mains cable that is plugged in to the AC Mains supply must be in a dry condition.

POPS15a is supplied with an “in line” PRCD device for use in countries that use 230VAC. DO NOT bypass this device or disable. The end of the AC Mains cable that is plugged in to the AC Mains supply must be in a dry condition.



NOTE: If a hard-wired GFCI or PRCD device is already located at the AC Mains source connection then the “in line” devices may be removed. **THIS MUST BE DONE BY A LICENSED ELECTRICIAN THAT IS FAMILIAR WITH ALL LOCAL AND NATIONAL ELECTRICAL CODES AND PRACTICES.**

DO NOT BYPASS THE GFCI OR PRCD DEVICE UNLESS YOU ARE FULLY LICENSED AND QUALIFIED TO DO SO!

Copies of this manual should be retained by both the system installer AND end user.

This manual must be read and understood and ALL warnings must be followed.

Follow all instructions to insure optimal product performance.

POPS15a's amplifier is a convection-cooled device and requires at least 7 inches (178 mm) of clearance behind the enclosure to allow the heat sink to adequately cool the internal electronics.

SEE SECTION BELOW ON THE **POPS15a** AND HIGH TEMPERATURE, AMBIENT ENVIRONMENTS AND SOLAR GAIN.

DO NOT INSTALL NEAR ANY HEAT SOURCES!

Use **ONLY** the supplied AC Mains connector. **DO NOT SUBSTITUTE!**

Protect the AC Mains power cord from being walked on or otherwise damaged and inspect for damaged connections and damaged insulation.

THE AC MAINS CONNECTION WHERE THE AC MAINS CABLE IS CONNECTED TO THE AC MAINS LINE MUST BE LOCATED IN A DRY LOCATION!

Use **ONLY** the supplied XLR/XLR cable. **DO NOT SUBSTITUTE!**

POPS15a may be suspended. **DO NOT SUSPEND ANY ITEMS OR OTHER ENCLOSURES BELOW THE POPS15a.**

DO NOT SUBSTITUTE SUSPENSION HARDWARE.

SUSPENSION SHOULD BE DONE BY SOMEONE FAMILIAR WITH LOCAL AND NATIONAL CODES AND SAFE SUSPENSION PRACTICES

WARRANTY

ONE SYSTEMS products are warranted by ONE SYSTEMS, INC. or ONE SYSTEMS Global Co. Ltd for a period of 5 years (3 years for all electronic products). This warranty period begins with the date of purchase by the original end-user of the product. All products are warranted against defects in materials and workmanship.

This Limited Warranty does not cover product abuse including, but not limited to, mechanical and thermal failures associated with excessive input power applied to ONE SYSTEMS loudspeaker systems. In addition, damage caused by accident, misuse or failure to observe instructions included in the following manuals: "Outdoor installation of loudspeakers" and "Rigging and Suspension of ONE SYSTEMS products" (These manuals may be found on the ONE SYSTEMS web site, www.ONESYSTEMS.com) is not covered. Other acts which are not the fault of ONE SYSTEMS are not covered. Defects or damages resulting from service, testing, product modification or alteration by someone other than ONE SYSTEMS or its authorized agents or service centers are not covered. ONE SYSTEMS is not responsible for misrepresentations by the seller or other parties.

All products covered by this limited warranty must be shipped to an authorized service center (see details below) prepaid. ONE SYSTEMS will pay all material and labor costs associated with repair or replacement of covered products. ONE SYSTEMS will pay all return costs associated with products covered under the terms of this limited warranty.

Limitation of Implied Warranties

ANY IMPLIED WARRANTIES, INCLUDING WITHOUT LIMITATION THE IMPLIED WARRANTIES OF MERCHANTABILITY AND FITNESS FOR A PARTICULAR PURPOSE, SHALL BE LIMITED TO THE DURATION OF THIS LIMITED WARRANTY, OTHERWISE THE REPAIR, REPLACEMENT, OR REFUND AS PROVIDED UNDER THIS EXPRESS LIMITED WARRANTY IS THE EXCLUSIVE REMEDY OF THE END USER (CONSUMER), AND IS PROVIDED IN LIEU OF ALL OTHER WARRANTIES, EXPRESS OR IMPLIED. IN NO EVENT SHALL ONE SYSTEMS, OR ANY OF ITS OPERATING DIVISIONS, BE LIABLE, WHETHER IN CONTRACT OR TORT (INCLUDING NEGLIGENCE) FOR DAMAGES IN EXCESS OF THE PURCHASE PRICE OF THE PRODUCT, ACCESSORY OR SOFTWARE, OR FOR ANY INDIRECT, INCIDENTAL, SPECIAL OR CONSEQUENTIAL DAMAGES OF ANY KIND, OR LOSS OF REVENUE OR PROFITS, LOSS OF BUSINESS, LOSS OF INFORMATION OR DATA, SOFTWARE OR APPLICATIONS OR OTHER FINANCIAL LOSS ARISING OUT OF OR IN CONNECTION WITH THE ABILITY OR INABILITY TO USE THE PRODUCTS, ACCESSORIES OR SOFTWARE TO THE FULL EXTENT THESE DAMAGES MAY BE DISCLAIMED BY LAW.

Some states and jurisdictions do not allow the limitation or exclusion of incidental or consequential damages, or limitation on the length of an implied warranty, so the above limitations or exclusions may not apply. This warranty provides specific legal rights, and other rights may exist from state to state or from one jurisdiction to another

REGULATORY AND SAFETY DATA

This product was tested to International Standards for safe operation. **POPS15a** is compliant with EN60065. Test certification may be obtained from One Systems.

CONTENTS

POPS15a system contains three cartons. The contents of the cartons are as follows:

POPS15a ENCLOSURE

One Portable Outdoor Powered System 15a (**POPS15a**) that includes a Bi-Amplified class D digital power amplifier system with on-board Digital Signal Processing (DSP).

AC MAINS CABLE REEL

100 ft. (30.5 m) of SJOW-rated AC mains cable with an IP 68-rated cable end connector designed to mate to the connector on **POPS15a**'s enclosure. The cable is supplied on a portable cable reel. This cable assembly consists of a moisture-resistant connector designed to be plugged into **POPS15a**.

The other end of this cable assembly consists of either a GFCI (Ground Fault Circuit Interrupter) and the appropriate mating plug for 115 V AC Mains voltage or a Portable Residual Current Device (PRCD) for 230 V AC Mains voltage.

NOTE: THIS CABLE END MUST BE IN A DRY LOCATION!



POPS15a cable end
Showing GFCI device

AC Mains End (MUST BE USED IN
DRY LOCATION)

INPUT/OUTPUT CABLE

100 FT. (30.5 M) of SJOW-rated two-conductor shielded input/output cable with an IP 67 rating. The cable is supplied on a portable cable reel.



RECOMMENDED ACCESSORIES

Although not supplied with the **POPS15a**, One Systems recommends using **POPS15a** enclosures with a high-quality loudspeaker stand. One Systems recommends using a stand with a “crank up” feature to allow easy vertical adjustments. On Stage Stands model SS8800B+ or equivalent is recommended. (On Stage Stands may be contacted at 1-800-289-8889 to determine the dealer closest to your location).

One Systems also highly recommends the **POPSSub a**. This active subwoofer is an ideal match for the **POPS15a**. **POPSSub a** and **POPS15a** are shown below:



NOTE: The **POPSSub a** is supplied with a pole designed to mount the **POPS15a** to the **POPSSub a**. DO NOT SUBSTITUTE OTHER POLES AND MOUNT ONLY THE **POPS15a** ON TOP OF THE **POPSSub a**!

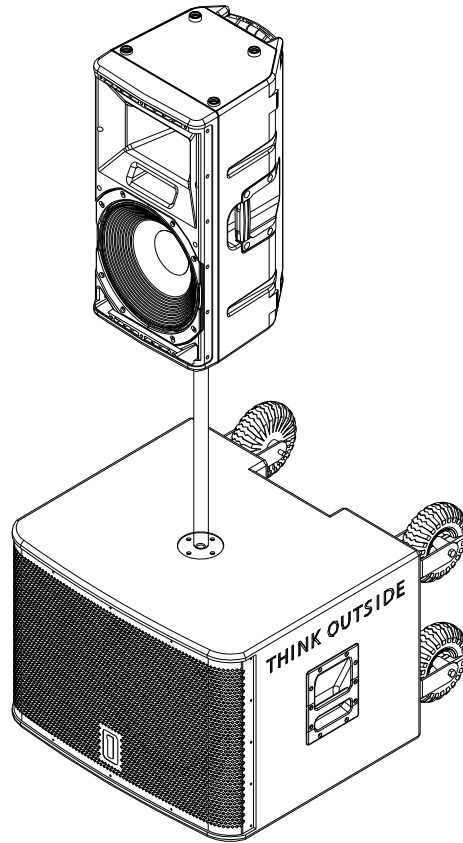

OTHER ACCESSORIES

One Systems also offers an M10 eyebolt kit that consists of 4 pieces of a 304-grade stainless steel eyebolt for use with **POPS15a**. This eye bolt kit is designed for temporary suspension of **POPS15a**.

FEATURES AND APPLICATIONS

POPS15a is a very unique product and may be used in “wet” outdoor environments. The AC Mains and input/output connectors are designed to provide a high degree of ingress protection. All mechanical connections are rated IP 67 or higher. **POPS15a** may be safely installed in outdoor environments as long as **ONLY** the supplied cables are utilized. **DO NOT SUBSTITUTE CABLES.**

POPS15a is a professional product and is designed to be used with a high-quality mixing console. **POPS15a** does not provide any additional, user-selectable, equalization or gain. Both equalization and gain functions should be provided by the mixing console.

One Systems does not feel that adding additional EQ and gain functions are appropriate for truly professional products. The addition of redundant functions

such as EQ and gain are usually the cause of clipping and distortion. These functions are easily provided by either an outboard mixing console or outboard EQ devices.

POPS15a features an onboard digital signal processor (DSP) that performs analog to digital conversion, equalization, high-order crossover, delay and system dynamics processing.

POPS AND HIGH AMBIENT TEMPERATURES

POPS15a has been designed to work in a wide range of ambient temperatures. When using **POPS15a** however, consideration must be given to both the ambient temperature and the added heat produced by exposure to direct sunlight.

In a “shaded” environment, **POPS15a** is rated for normal operation up to 40° C (104° F). In environments where **POPS15a** is subjected to direct sunlight, a portion of that direct solar energy is absorbed by the enclosure and the external heat sink. **POPS15a**’s color and resin formulations have been specifically designed to minimize the thermal/solar gain of the enclosure and the heat sink has been clear- anodized to minimize its solar gain as well.

It is recommended that whenever possible **POPS15a** should be used in either a shaded area, or shade provided via an external “umbrella” type of sun shade.

Solar gain precautions should be taken any time the ambient (air) temperature is 90 F (32 C) or higher and if **POPS15a** is intended to be used in direct sunlight.

SETUP AND USE OF POPS15a

All connections to **POPS15a** are made on the rear amplifier panel. The input panel is shown below:



ON/Off Switch

AC MAINS CONNECTION

Prior to connecting the AC mains cable, insure that the AC mains switch on the **POPS15a** is in the OFF position.



NOTE: If the POPS 15a is being used with the POPS Sub a, the best practice is to turn on the POPS 15a PRIOR to turning on the POPS Sub a. During the turn off sequence, either the POPS 15a or the POPS Sub a may be turned off first!



NOTE: DO NOT CONNECT THE AC MAINS CABLE TO **POPS15a** IF WATER OR MOISTURE IS PRESENT IN EITHER END OF THE CONNECTOR!



POPS15a MUST be connected to the correct AC Mains voltage! There are two (2) versions of the **POPS15a**, both use the same enclosure but different AC Mains cables: 115 VAC or 230 VAC. You MUST insure that you have the correct AC Mains cable version that matches your AC Mains voltage! The required AC mains frequency is between 50 Hz and 60 Hz.

POPS15a uses a waterproof AC mains connector system. To mate the AC mains cable with the AC mains connector on the amplifier's input plate, align the cable end with the amplifier panel's connector and push with sufficient force until you hear a "click" sound that indicates the cable and chassis connector are properly mated. Support the **POPS15a**'s enclosure with one hand while performing this operation. The AC mains connector is shown below. It is located on the lower portion of the **POPS15a**'s input panel.



INSURE THAT THE AC MAINS CABLE IS SECURLY CONNECTED AND "LOCKED" INTO POSTION. DO NOT USE **POPS15a** IF THE AC MAINS CONNECTOR IS NOT SECURELY-MATED TO THE AMPLIFIER MODULE!



AC Mains panel connector



NOTE: ALWAYS turn off the AC mains power BEFORE attempting to disconnect the AC mains cable from **POPS15a's** amplifier module!

To disconnect the cable end of the AC mains connector pull back on the collar of the cable end connector in the direction shown on the connector. While pulling back on the collar pull the cable end connector away from the chassis connector. It is necessary to physically support the enclosure while disconnecting the AC Mains connector to avoid pulling the enclosure over if the enclosure is not securely mounted.

The AC mains supply end of the cable is shown in the image below (Image 1)

Once the AC mains cable is connected to **POPS15a's** amplifier, the other end of the AC mains cable may be connected to the AC mains supply. This end of the AC mains cable is a standard connector and **MUST** be connected in an area that is **DRY**. The figure below shows both ends of the AC mains cable. The connector on the right side of this photo is the IP 68-rated cable end that should be connected to the AC mains input on **POPS15a's** amplifier module. The connector on the left side of this photo is connected to the AC mains supply located in a dry area.

NOTE: The configuration of the connector on the left side will vary depending on which region of the world **POPS15a** is used in.



AC mains cable ends (Image 1)

AC Mains supply end (115 V AC version shown)



DO NOT CONNECT THE AC MAINS END OF THE AC MAINS CABLE IN AN AREA THAT IS WET OR SUBJECT TO CONDENSATION OR DAMP CONDITIONS!

The AC Mains end of the cable assembly uses an “in line” GFCI device (115 V AC) or a PRCD device (230 V AC). DO NOT disconnect this device!

NOTE: The AC Mains cable is an extension cable. It is a high-quality cable with low line loss. Connecting the AC Mains cable to another extension cable will produce additional line loss and can result in low ac mains voltage at the **POPS** amplifier module. It is not recommended that additional extension cables be used with this AC Mains connector.

Once the AC mains cable is securely connected to the amplifier and AC mains supply, **POPS15a** may be powered up. A good practice is to make sure the audio levels on the mixer’s output (or other source output) are reduced or muted prior to applying power to **POPS15a**.

NOTE: When power is applied to **POPS15a** and the unit is turned on there is a short delay before the pilot light illuminates.



Signal Present

Pilot Light



NOTE: If the pilot light does not illuminate within 30 seconds, the unit may be in a FAULT CONDITION. The unit should be returned to One Systems for evaluation.

THERE ARE NO USER-SERVICABLE PARTS INSIDE. DO NOT REMOVE THE AMPLIFIER MODULE!

AUDIO CONNECTIONS

POPS15a includes two male XLR connectors. This configuration differs from the standard male input and female out/thru due to the water and moisture requirements of the product. Both the input and output/thru XLR connectors on the **POPS15a** are made by Neutrik and require use of Neutrik connectors NC3FXX-HD-D. The supplied XLR to XLR audio cable has two of the NC3FXX-HD-D connectors.

The image below illustrates the top portion of the **POPS15a** input plate. Both the audio input and audio thru connectors are shown. In this image both connectors are shown with their water covers in place.

POPS15a also includes a "signal present" indicator and is positioned immediately below the Pilot light. This indicator will illuminate when an audio signal is present at the input to the system. The threshold is approximately -25dBV.



When the audio connectors are not in use the water covers should be inserted in the XLR connector. (Example: If the audio input is being used but the audio thru connector is not being used the water cover should be inserted in the audio thru XLR)



The image above shows both the INPUT and THRU connections with their water covers in place.

Connect the audio out from the console/mixer using the supplied XLR to XLR cable.

POPS15a also features an audio output/thru. This connection **MUST** also use a Neutrik NC3FXX-HD-D cable end connector. The picture below shows the water cover removed from the image for clarity. The water covers are permanently attached to **POPS15a's** input plate and will hang down from the panel when not inserted in the audio input or audio thru XLR connectors.



Input



NOTE: Care must be exercised to insure that each end of the XLR connector is securely seated into the mating panel connector and gets locked into place. Insert the connector into the panel's connector until a soft "click" is heard. This indicates the cable end is properly retained in the panel connector. To remove the XLR connector, simply squeeze the rubber "boot" of the connector on the top and bottom as near to the panel end of the boot as possible.

Failure to properly seat and secure the connector will significantly reduce the water protection features designed into the connector's assembly.



DO NOT USE THE CONNECTOR IF MOISTURE IS PRESENT IN THE PANEL CUTOUT OF THE XLR CONNECTOR. THE PANEL'S CONNECTOR MUST BE DRIED PRIOR TO CONNECTION!

POPS15a's input section also allows for "paralleling" multiple **POPS15a** systems. This function is achieved by using the output/thru XLR connector located next to the input XLR connector on **POPS15a's** amplifier module. This input is shown below.



Input

Thru

NOTE: Neutrik NC3FXX-HD-D connectors **MUST** be used for ALL audio connections on **POPS15a!**



WARNING: DO NOT SUBSTITUTE “NORMAL” XLR CABLE CONNECTORS. FAILURE TO USE NEUTRIK NC3FXX-HD-D CONNECTORS WILL COMPROMISE THE WATER / MOISTURE RATING OF **POPS15a** AND MAY RESULT IN UNSAFE CONDITIONS. NEUTRIK NC3FXX-HD-D CONNECTORS MUST BE USED FOR ALL CONNECTIONS ON **POPS15a**.

RIGGING AND SUSPENSION OF POPS15a

POPS15a features 7 x M10 (metric) stainless steel rigging points. The enclosure may be suspended for temporary installations. There are four M10 points on the top of the enclosure, two on the bottom of the enclosure and a single “pull up” point on the rear, bottom portion of the enclosure.

WARNING: The single M10 point on the rear of the enclosure is NOT intended for suspension of the enclosure and should NOT be used for suspension. The M10 point on the rear of the enclosure is for pull up and aiming ONLY!

The M10 rigging points are shown in the image below.

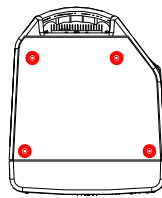

TOP

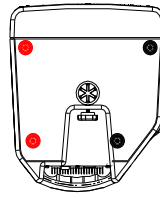

BOTTOM

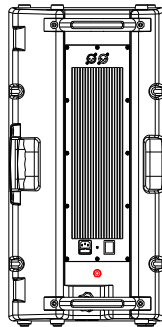

BACK
PULL UP ONLY!

Rigging Points Shown Above

DO NOT USE THE BACK POINT FOR SUSPENSION
THIS POINT IS FOR “PULL UP” ONLY!



POPS15a may be mounted to any high-quality loudspeaker stand with a standard 1.375 inch (35 mm) diameter mounting pole. The mounting pole **MUST** be located on a level surface that is capable of safely supporting the weight of both the loudspeaker stand and the **POPS15a**. It is necessary to verify safe operation with the loudspeaker stand supplier/manufacturer.

DO NOT ADD OR SUSPEND ANY ITEMS TO THE POPS15a OR LOUDSPEAKER'S STAND



WARNING

DO NOT ATTEMPT TO SUSPEND ONE SYSTEMS PRODUCTS WITHOUT UNDERSTANDING LOCAL AND NATIONAL CODES THAT APPLY TO OVERHEAD SUSPENSION OF PRODUCTS.

DO NOT ATTEMPT TO SUSPEND ONE SYSTEMS PRODUCTS UNLESS YOU ARE A PROFESSIONAL WITH KNOWLEDGE OF LOCAL AND NATIONAL CODES RELATED TO SAFE SUSPENSION AND ARE EXPERIENCED IN SUSPENDING PRODUCTS OVERHEAD.

ONE SYSTEMS IS NOT RESPONSIBLE FOR FAILURES RELATED TO NON-COMPLIANCE WITH LOCAL AND NATIONAL CODES AND SAFE SUSPENSION PRACTICE.

DO NOT ATTEMPT TO SUSPEND THIS PRODUCT WITHOUT READING AND UNDERSTANDING THE DOCUMENT “ Rigging and Suspension of ONE SYSTEMS Products”. THIS DOCUMENT MAY BE FOUND AT: www.onesystems.com. In the “Education” section of the One Systems website.

ALL ASSOCIATED RIGGING IS THE RESPONSIBILITY OF OTHERS.

USING POPS15a (Application and Trouble-Shooting Tips)

POPS15a is a high-quality professional sound reinforcement system designed for use in both direct weather outdoor applications as well as high ambient noise indoor applications. Some basic precautions will insure long-term reliability.



Although **POPS15a** is designed for direct weather applications insure that no part of the front of the enclosure is directed upward beyond vertical. The high-frequency section of **POPS15a** is horn-loaded and water can collect in the horn's throat and driver if the horn is tilted upward.

EQUALIZATION AND GAIN

POPS15a has all the required equalization and gain functions included in its internal Digital Signal Processor (DSP). Both the equalization and gain functions have been optimized for flat frequency response and maximized system dynamics. **POPS15a** does not have user-settable external gain or EQ.

All system gain should be set via the outboard mixing console. The mixing console should be capable of providing sufficient output signal levels to supply the necessary voltage levels to drive **POPS15a** to full power and still insure adequate headroom in the mixing console. The mixing console needs to be capable of driving 100 feet (30.5 m) of balanced cable as well as the **POPS15a**.

NOTE: When both **POPS15a** and **POPSSub a** are used as a system, care should be exercised since the **POPSSub a** does feature an external, user-adjustable, gain control to select the desired levels of bass and sub-bass output relative to the **POPS15a**'s full-range output.

If additional equalization is required, care should be taken to avoid excessive EQ in any band, but particularly at low frequencies. Excessive equalization can produce "band selective" clipping and distortion. All EQ boost levels should be monitored if system distortion is present.

Applications that require excessive low frequency equalization are almost always an indication that a subwoofer is required. One Systems offers the **POPSSub a**. **POPSSub a** is a companion product designed for use with **POPS15a** and will provide substantial low frequency acoustic output.

DISTORTED SOUND

When desired levels exceed **POPS15a**'s gain structure limitations, the internal dynamics processing functions will engage and provide system protection. However, it is still possible to "overdrive" the input section of the system or to overdrive, or clip the output stages of the source electronics. If distorted sound is present the following steps should be taken:

1. Verify that the mixer's output is not clipping or overloaded. If the output metering section of the mixing console is continuously in the "red" then the

output level should be reduced. (Occasional “red” indications are usually fine, depending on the mixing console’s output capability).

1. Also verify that any other electronic devices in the signal chain are not being overdriven.
2. Verify that excessive equalization is not present anywhere in the signal chain.
3. Verify that AC mains levels are within the required range.



Voltage measurements on the AC Mains should be performed by a licensed electrician or individual trained in making high voltage measurements.

NO SOUND

1. Verify that signal is present on the input of **POPS15a**. If the signal present light is illuminated and there is still no output please contact your One Systems dealer or One Systems directly.
2. Verify that there is AC Mains voltage on **POPS15a**'s AC Mains input
3. If AC Mains voltage is present, verify that **POPS15a**'s fuse is not blown. If **POPS15a**'s fuse is blown you **MUST** replace it with the type noted on the panel directly above the fuse holder!



NOTE: IF THE FUSE IS BLOWN, REPLACE ONLY WITH THE SAME TYPE OF FUSE. THIS FUSE TYPE IS NOTED ON THE SPEAKER'S INPUT PANEL NEAR THE FUSE HOLDER. THE LOCATION OF THE FUSE HOLDER IS SHOWN BELOW.



Fuse Holder



The fuse holder is a waterproof design. Insure that its gasket is properly seated when replacing the fuse. Insure that the fuse holder's cover is securely tightened. **DO NOT OVERTIGHTEN THE FUSE HOLDER COVER.**

PRODUCT SERVICE



There are **NO** user-serviceable parts inside **POPS15a** (see "Replacement of Components" section below for clarification and exceptions to this statement).

POPS15a's amplifier module **MUST** be serviced by an individual authorized by One Systems.

POPS15a's amplifier is attached to the enclosure using 12 x M4 stainless steel machine screws with special "sealing washers". The unique self-sealing feature of these washers forms a waterproof seal between the amplifier module and the enclosure.

The washers are supplied by Gaynor Industries and are Gaynor Industries part number LTN37164

DO NOT SUBSTITUTE WASHER TYPES.

Replacement of Components



DO NOT ATTEMPT ANY REPAIRS UNLESS POPS15a's AMPLIFIER HAS BEEN DISCONNECTED FROM THE AC MAINS SOURCE!

REPLACEMENT OF COMPONENTS MUST BE PERFORMED BY A QUALIFIED TECHNICIAN OR ONE KNOWLEDGABLE IN THE REPLACEMENT OF TRANSDUCER COMPONENTS!

In the event of woofer failure, the woofer may be accessed by removing the front grille and then removing the woofer. This should be done by a qualified technician or contractor. There is no need to remove the amplifier's panel in the event of a woofer failure. Insure that proper wiring polarity is observed. Note the wiring polarity before disconnecting the woofer and observe this polarity when replacing it.

In the event of a compression driver failure, the amplifier module must be removed to gain access to the compression driver. Remove the 12 stainless steel screws located around the perimeter of the amplifier module.



USE EXTREME CARE WHEN HANDLING **POPS15a**'s AMPLIFIER MODULE. THE COMPONENTS ON IT ARE FRAGILE AND THE MODULE MUST NOT BE SET DOWN ON THE COMPONENT SIDE OR DAMAGE WILL OCCUR!

Care should be exercised when disconnecting the amplifier module from the woofer and the compression driver. Be sure to observe the wiring polarity of both the woofer and the compression driver.

NOTE: The wires for the compression driver may be disconnected from the **POPS15a**'s amplifier by simply removing the Phoenix connector with the orange and yellow wires from the terminal block on the amplifier module. Before removing, insure that these are the wires running to the compression driver.

The compression driver is a "screw on" type and is easily removed once the amplifier module has been removed. Once the compression driver's diaphragm has been replaced and re-mounted on the horn, the amplifier may be re-mounted.

Insure that both the woofer and compression driver are connected with the correct polarity.

Use the same stainless steel screws and LTN37164 washers to mount the amplifier's module to the enclosure. Insure that no wires are located between the amplifier module and the enclosure when re-mounting the amplifier module.



ONE SYSTEMS®

PORTABLE OUTDOOR POWERED SYSTEM

POPSSUBa USER MANUAL



The exclamation point within an equilateral triangle is intended to alert the user to the presence of important operation and maintenance instructions.



High voltage

The lightning flash with arrowhead symbol within an equilateral triangle is intended to alert the user to the presence of uninsulated “dangerous voltage” within the products enclosure that may be of sufficient magnitude to constitute a risk of electric shock to persons.



NOTE: The POPS Sub uses an auto-detection circuit that senses and adjusts internal operating voltages to the AC Mains supply. The POPS Sub will operate between 104VAC and 253VAC. However, there are separate AC Mains cable assemblies for 115VAC or 230VAC operation!

Although the AC Mains is automatically selected the user must insure that the proper AC Mains cable is supplied (GFCI enabled for 115VAC operation and PRCD enabled for 230VAC operation)

	CAUTION	
	RISK OF ELECTRIC SHOCK, DO NOT OPEN!	
CAUTION: TO REDUCE THE RISK OF ELECTRICAL SHOCK, DO NOT REMOVE COVER. NO USER SERVICEABLE PARTS INSIDE. REFER SERVICING TO QUALIFIED SERVICE PERSONNEL.		

The Portable Outdoor Powered System Sub (**POPSSub**) was designed by One Systems to provide additional bass and sub bass response for the **POPS15** system. The **POPSSub** features an 18 inch (457 mm) diameter woofer that delivers extremely high acoustic output capability at very low frequencies. The **POPSSub** was designed for use in any direct weather outdoor application, such as sporting events, theme park events, civic celebrations and general outdoor presentations. **POPSSub** was designed for ALL weather applications and all components, including all electronics and transducers have been developed for use in rain, snow and other inclement weather applications. The highly portable design is also ideal for portable applications in gymnasiums, indoor and outdoor swimming pools and meeting rooms. **POPSSub** features large diameter pneumatic (air-filled) wheels to allow for easy transportation on soft, wet, grassy surfaces such as football fields, soccer pitches, baseball diamonds etc.

Specifications

Frequency Response:	40 Hz – 80 Hz
Coverage Pattern:	Essentially omnidirectional
Input:	3-Pin XLR-type (IP 67) (Pin 2 +)
Outputs:	Thru (balanced) High Pass Filtered out (balanced)
Power	
Peak - Total System:	2,000 Watts
Continuous- Total System:	1,000 Watts
AC Mains Power:	104 V AC – 253 V AC (50 Hz – 60 Hz)
Max Acoustic Output (Peak):	128dB*
Weather Performance:	IEC 529 / IP 56
Supplied Accessories:	AC Mains Cable (100Ft / 30.5 m) Input /Output XLR-XLR (6.6 Ft / 2 m) 1.375 inch (35 mm) manual crank-up pole

Dimensions (H X W X D):

344.5 X 790 X 909.8 mm
21.44 X 31.1 X 35.82 inches

Weight

40 kg (88.2 lbs)

Operating Temperature

0C – 40C (32F – 104F)

Available Accessories

POPS 15

* NOTE: Max Acoustic Output is based on smoothed overall system response, not peak driver response.

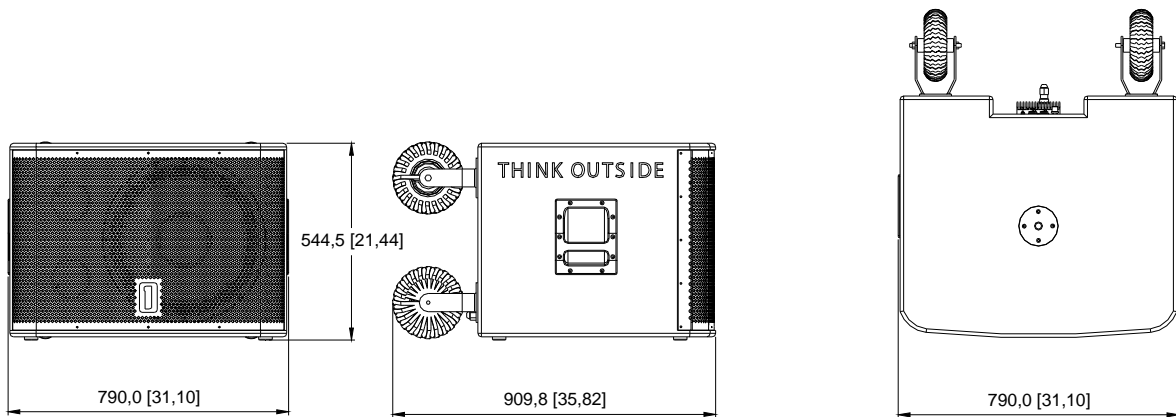

The image below shows **POPS15** mounted on the **POPSSub** using the pole supplied with the **POPSSub**:

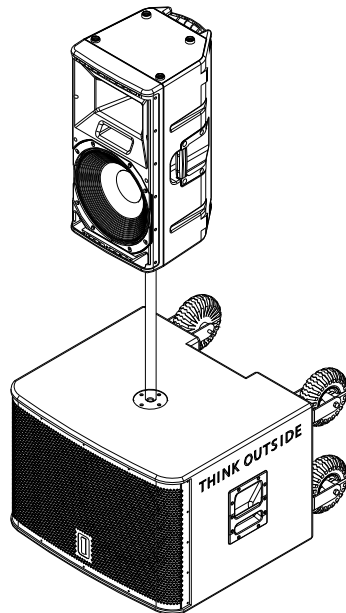



Read all of the instructions included in this manual

NOTE: The AC mains supply end of the **POPS** Sub power cable **MUST** be plugged into a supply source that has a GROUND FAULT CIRCUIT INTERRUPTER (GFCI). The 115 VAC version is supplied with an in-line GFCI. The 230 VAC version is supplied with a Portable Residual Current Device (PRCD). In Europe, these devices are also referred to as Residual Current Devices or Residual Current Circuit Breakers.

NOTE: THE RESET ON THIS DEVICE SHOULD BE TESTED TO VERIFY PROPER OPERATION OF THE SAFETY DEVICE!

The POPS Sub is supplied with an “in line” GFCI device for use in countries that use 115VAC. **DO NOT** bypass this device or disable. The end of the AC Mains cable that is plugged in to the AC Mains supply must be in a dry condition.

The POPS Sub is supplied with an “in line” PRCD device for use in countries that use 230VAC. **DO NOT** bypass this device or disable. The end of the AC Mains cable that is plugged in to the AC Mains supply must be in a dry condition.



NOTE: If a hard-wired GFCI or PRCD device is already located at the AC Mains source connection then the “in line” devices may be removed. **THIS MUST BE DONE BY A LICENSED ELECTRICIAN THAT IS FAMILIAR WITH ALL LOCAL AND NATIONAL ELECTRICAL CODES AND PRACTICES.**

DO NOT BYPASS THE GFCI OR PRCD DEVICE UNLESS YOU ARE FULLY LICENSED AND QUALIFIED TO DO SO!

Copies of this manual should be retained by both the system installer **AND** end user.

- This manual must be read and understood and **ALL** warnings must be followed.
- Follow all instructions to insure optimal product performance.
- Copies of this manual should be retained by both the system installer **AND** end user.
- This manual must be read and understood and **ALL** warnings must be followed.
- Follow all instructions to insure optimal product performance.

POPSSub's amplifier is a convection-cooled device and requires at least 7 inches (178 mm) of clearance behind the enclosure to allow the heat sink to adequately cool the internal electronics.

SEE SECTION BELOW ON **POPSSub** AND HIGH TEMPERATURE AMBIENT ENVIRONMENTS AND SOLAR GAIN.

DO NOT INSTALL NEAR ANY HEAT SOURCES!

Use ONLY the supplied AC Mains connector. DO NOT SUBSTITUTE!

Protect the AC Mains power cord from being walked on or otherwise damaged and inspect for damaged connections and damaged insulation.

Use ONLY the supplied XLR/XLR cable. DO NOT SUBSTITUTE!

There are NO user serviceable parts inside the enclosure. DO NOT REMOVE THE AMPLIFIER MODULE! (See Service section for details OR contact One Systems)

WARRANTY

ONE SYSTEMS products are warranted by ONE SYSTEMS, Inc, and ONE SYSTEMS GLOBAL Co. Ltd for a period of 5 years. (3 years for all electronic products) This warranty period begins with the date of purchase by the original end-user of the product. All products are warranted against defects in materials and workmanship.

This Limited Warranty does not cover product abuse including, but not limited to, mechanical and thermal failures associated with excessive input power applied to ONE SYSTEMS loudspeaker systems. In addition, damage caused by accident, misuse or failure to observe instructions included in the following manuals: "Outdoor installation of loudspeakers" and "Rigging and Suspension of ONE SYSTEMS products" (These manuals may be found on the ONE SYSTEMS web site, www.ONESYSTEMS.com) is not covered. Other acts which are not the fault of ONE SYSTEMS are not covered. Defects or damages resulting from service, testing, product modification or alteration by someone other than ONE SYSTEMS or its authorized agents or service centers are not covered. ONE SYSTEMS is not responsible for misrepresentations by the seller or other parties.

All products covered by this limited warranty must be shipped to an authorized service center (see details below) prepaid. ONE SYSTEMS will pay all material and labor costs associated with repair or replacement of covered products. ONE SYSTEMS will pay all return costs associated with products covered under the terms of this limited warranty.

Limitation of Implied Warranties

ANY IMPLIED WARRANTIES, INCLUDING WITHOUT LIMITATION THE IMPLIED WARRANTIES OF MERCHANTABILITY AND FITNESS FOR A PARTICULAR PURPOSE, SHALL BE LIMITED TO THE DURATION OF THIS LIMITED WARRANTY, OTHERWISE THE REPAIR, REPLACEMENT, OR REFUND AS PROVIDED UNDER THIS EXPRESS LIMITED WARRANTY IS THE EXCLUSIVE REMEDY OF THE END USER (CONSUMER), AND IS PROVIDED IN LIEU OF ALL OTHER WARRANTIES, EXPRESS OR IMPLIED. IN NO EVENT SHALL ONE SYSTEMS, OR ANY OF ITS OPERATING DIVISIONS, BE LIABLE, WHETHER IN CONTRACT OR TORT (INCLUDING NEGLIGENCE) FOR DAMAGES IN EXCESS OF THE PURCHASE PRICE OF THE PRODUCT, ACCESSORY OR SOFTWARE, OR FOR ANY INDIRECT, INCIDENTAL, SPECIAL OR CONSEQUENTIAL DAMAGES OF ANY KIND, OR LOSS OF REVENUE OR PROFITS, LOSS OF BUSINESS, LOSS OF INFORMATION OR DATA, SOFTWARE OR APPLICATIONS OR OTHER FINANCIAL LOSS ARISING OUT OF OR IN CONNECTION WITH THE ABILITY OR INABILITY TO USE THE PRODUCTS, ACCESSORIES OR SOFTWARE TO THE FULL EXTENT THESE DAMAGES MAY BE DISCLAIMED BY LAW.

Some states and jurisdictions do not allow the limitation or exclusion of incidental or consequential damages, or limitation on the length of an implied warranty, so the above limitations or exclusions may not apply. This warranty provides specific legal rights, and other rights may exist from state to state or from one jurisdiction to another.

REGULATORY AND SAFETY DATA

This product was tested to International Standards for safe operation. The **POPSSub** is compliant with EN60065. Test certification may be obtained from One Systems.

CONTENTS

The **POPSSub** system is shipped in three cartons. The contents of the cartons are as follows:

POPSSub ENCLOSURE

One Portable Outdoor Powered Systems Sub (**POPSSub**) that includes a class-D digital power amplifier. The complete **POPSSub** is rated to IEC 529 / IP 56.

Also included in this carton is a 1.375 inch (35 mm) standard diameter mounting pole for use with **POPS15**.



NOTE: The POPS Sub MUST be located on level ground when the POPS 15 is mounted on top of the supplied pole.



DO NOT USE OTHER SYSTEMS THAN THE **POPS15** WHEN MOUNTING ON THE POLE.

DO NOT SUBSTITUTE OTHER MOUNTING POLES ON **POPS** Sub's ENCLOSURE!

AC MAINS CABLE

100ft (30.5 m) of SJOW-rated AC mains cable with an IP 68-rated cable end connector designed to mate to the input panel of the **POPSSub** enclosure.

INPUT/OUTPUT CABLE

6.6 FT. (2 M) of SJOW-rated two-conductor shielded input/output cable with an IP 67 rating.

FEATURES AND APPLICATIONS

POPSSub is a very unique product and may be used in “wet” outdoor environments. Its AC Mains and input/output connectors are designed to provide a high degree of ingress protection. All mechanical connections are rated IP 67 or higher. **POPSSub** may be safely installed in outdoor environments as long as **ONLY** the supplied cables are utilized. **DO NOT SUBSTITUTE CABLES.**

POPSSub is a professional product and is designed to be used with a high-quality mixing console. The **POPSSub** does not provide any additional, user-selectable equalization. Equalization functions should be provided by the mixing console or other outboard devices.

One Systems does not feel that adding additional EQ functions are appropriate for truly professional products. The addition of redundant functions such as EQ can cause clipping and distortion.

The system's dynamics processing consists of a compressor/limiter function designed to provide both ultra fast threshold system protection and maximized system dynamics.

POPS AND HIGH AMBIENT TEMPERATURES

POPSSub has been designed to work in a wide range of ambient temperatures. When using the **POPSSub** however, consideration must be given to the ambient temperature as well as the heat produced by exposure to direct sunlight.

In a "shaded" environment, the **POPSSub** is rated for normal operation up to 40° C (104° F). In environments where **POPSSub** is subjected to direct sunlight, a portion of that direct solar energy is absorbed by the enclosure and the external heat sink. **POPSSub**'s color and resin formulations have been specifically designed to minimize the thermal/solar gain of the enclosure and the heat sink has been clear-anodized to minimize its solar gain as well.

It is recommended that whenever possible, **POPSSub** should be used in either a shaded area, or in shade provided via an external "umbrella" type of sun shade.

Solar gain precautions should be taken any time the ambient (air) temperature is 90° F (32° C) or higher and if **POPSSub** is intended to be used in direct sunlight.

SETUP AND USE OF POPSSub

AC MAINS CONNECTION

The AC mains are connected to the POPS Sub using the supplied cable ONLY. DO NOT SUBSTITUTE!



NOTE: If the POPS Sub is being used with the POPS 15 the best practice is to turn on the POPS 15 PRIOR to turning on the POPS Sub. During the turn off sequence, either the POPS 15 or the POPS Sub may be turned off first!

Prior to connecting the AC mains cable, insure that the AC mains switch on the **POPSSub** is in the OFF position.



On/Off Switch



NOTE: DO NOT CONNECT THE AC MAINS CABLE TO THE POPSSub IF WATER OR MOISTURE IS PRESENT IN THE CONNECTOR!

POPSSub will operate on any AC mains voltage between 104 volts and 253 volts. The required AC mains frequency is between 50 Hz and 60 Hz.

POPSSub uses a waterproof AC mains connector system. To mate the AC mains cable with the AC mains connector on the input plate, align the cable end with the amplifier's panel connector and push with sufficient force until you hear a "click" sound that indicates the cable end and chassis end are properly mated. Support the **POPSSub**'s enclosure with one hand while performing this operation. The AC mains connector is shown below. It is located on the lower portion of **POPSSub**'s input panel.



AC Mains panel connector



INSURE THAT THE AC MAINS CABLE IS SECURLY CONNECTED AND IS “LOCKED” INTO POSTION. DO NOT USE THE **POPSSub** IF THE AC MAINS CONNECTOR IS NOT SECURLY-MATED TO THE AMPLIFIER MODULE!



DO NOT CONNECT THE AC MAINS END OF THE AC MAINS CABLE IN AN AREA THAT IS WET OR SUBJECT TO CONDENSATION OR DAMP CONDITIONS!

The AC Mains end of the cable assembly uses an “in-line” GFCI device (115 V AC) or a PRCD device (230 V AC). DO NOT disconnect this device!

To disconnect the cable end of the AC mains connector, pull back on the collar of the cable’s end connector in the direction shown on the connector. While pulling back on the collar, pull the cable end connector away from the chassis connector.



NOTE: ALWAYS turn off the AC mains power BEFORE attempting to disconnect the AC mains cable from **POPSSub**’s amplifier module!

The AC mains supply end of the cable is shown in the image below.



Cable end
(connected to POPS Sub)

AC Mains end

Once the AC mains cable is connected to **POPSSub**’s electronics, the other end of the AC mains cable may be connected to the AC mains supply. This end of the AC mains cable is a standard connector and MUST be connected in an area that is DRY. The figure above represents both ends of the AC mains cable. The connector on the left side of this figure is the IP 68-rated cable end that should be

connected to the AC mains input on **POPSSub**'s amplifier module. The connector on the right side of this image is connected to the AC mains supply located in a dry area. (The connector shown on the right side will vary depending on local AC Mains connection requirements!)

NOTE: The AC Mains cable is an extension cable. It is a high-quality cable with low line loss. Connecting the AC Mains cable to another extension cable will produce additional line loss and can result in low ac mains voltage at the POPSSub amplifier module. It is not recommended that additional extension cables be used with this AC Mains connector.

Once the AC mains cable is securely connected to both the amplifier and AC mains supply end, **POPSSub** may be powered up. A good practice is to make sure the audio levels on the mixer's output (or other source output) are reduced or muted prior to applying power to **POPSSub**.

NOTE: When power is applied to the **POPSSub** and the unit is turned on, there is a short delay before the pilot light illuminates.



Pilot Light



NOTE: If the pilot light does not illuminate within 30 seconds the unit may be in a **FAULT CONDITION**. The unit should be returned to One Systems for evaluation.

THERE ARE NO USER-SERVICABLE PARTS INSIDE. DO NOT REMOVE THE AMPLIFIER MODULE!

AUDIO CONNECTIONS

POPSSub includes two male XLR connectors. This configuration differs from the standard male input and female out/thru due to the water and moisture requirements of this product. Both the input and output/thru XLR connectors on the POPSSub are male Neutrik plugs and require Neutrik cable end connectors

NC3FXX-HD-D. The supplied XLR to XLR audio cable has two of the NC3FXX-HD-D connectors.

The POPS Sub also features a High Pass Filters output. This output is a 4th order (24dB/Octave) high pass output designed to provide a drive signal to the POPS 15 enclosure. This is a balanced output with pin 2 positive.

The image below illustrates the top portion of **POPSSub**'s input plate. Both the audio input and audio thru connectors as well as the HP filtered output are shown. In this image all connectors are shown with their water covers in place.

NOTE: **POPSSub** also features an audio "signal present" indicator LED that is next to the Pilot Light. This indicator will illuminate when there is an audio signal present at the XLR input. The threshold for this indicator is approximately -25dBV.



When the audio connectors are not in use, the water covers should be inserted in the XLR connector. (Example: If the audio input is being used but the audio thru connector is not being used, the water cover should be inserted in the audio thru XLR to prevent moisture intrusion).



Audio Input, Thru and HP Filtered Weather Covers

The image above shows both the input and thru connectors with water covers in place.



NOTE: Care must be exercised to insure that each end of the XLR connector is securely seated in the mating panel connector and locked into place. Insert the connector into the panel connector until a soft "click" is heard. This indicates the

cable end is properly mated to the panel connector. To remove the XLR connector simply squeeze the rubber “boot” of the connector on the top and bottom as near to the panel end of the boot as possible.

Failure to properly seat and secure the connector will reduce the water protection features designed into the connector assembly.



Audio Input

The POPS Sub also features an audio “thru” output. This connection MUST also use a Neutrik NC3FXX-HD-D cable end connector.



Audio Input

Audio “Thru” Output

Connect the audio output from the console/mixer using the supplied XLR to XLR cable using the Audio Input XLR as shown below.

The wiring is also shown below for the **POPS**Sub and **POPS**15.

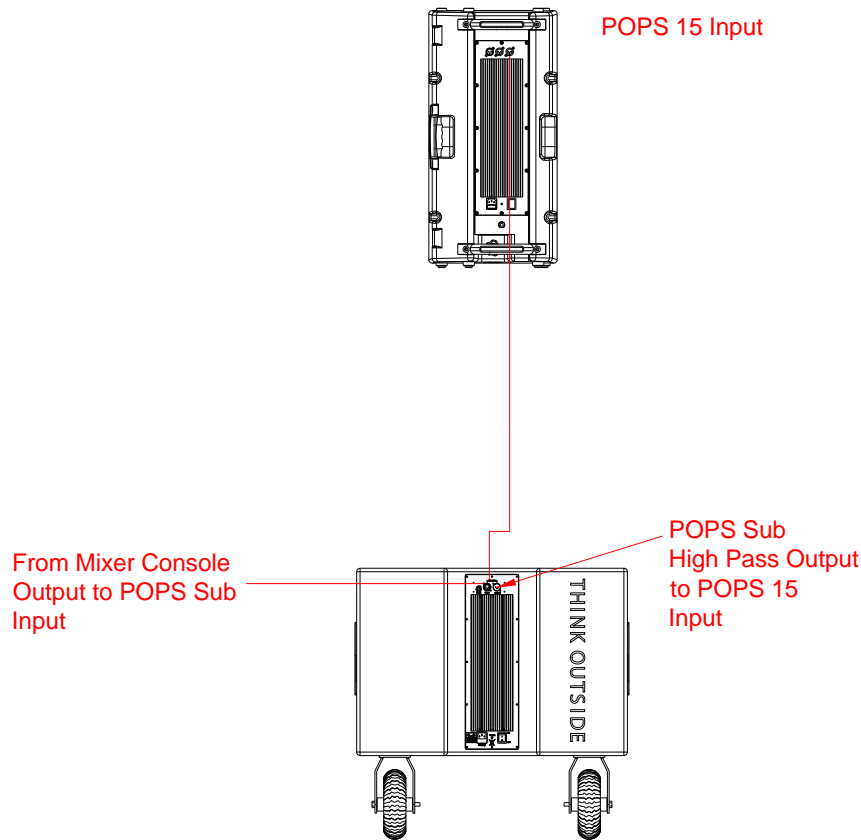

As noted above, the mixing console's output is wired to the **POPS** Sub's input. The **POPS** Sub's High-Pass Output is wired to the input of the **POPS** 15. The XLR connectors supplied with **POPS**15 and **POPS**Sub must be used for these connections. **DO NOT SUBSTITUTE!**



DO NOT USE THE CONNECTOR IF MOISTURE IS PRESENT IN THE PANEL PORTION OF THE XLR CONNECTOR. THE PANEL'S CONNECTOR MUST BE DRIED PRIOR TO CONNECTION!



WARNING: DO NOT SUBSTITUTE XLR CABLE END CONNECTORS. FAILURE TO USE NEUTRIK NC3FXX-HD-D CABLE END CONNECTORS WILL COMPROMISE THE WATER / MOISTURE RATING OF THE **POPSSUB AND MAY RESULT IN UNSAFE CONDITIONS. NEUTRIK NC3FXX-HD-D CONNECTORS MUST BE USED FOR ALL CONNECTIONS ON THE **POPS**SUB.**

USING THE POPSSub (Application and Trouble-Shooting Tips)

POPSSub is a high-quality professional sound reinforcement system designed for use in both direct weather outdoor applications as well as high ambient noise indoor applications. The **POPSSub** is designed to be used with the **POPS15**. Some basic precautions will insure long-term reliability.



INSURE THAT THE **POPSSub** IS PLACED ON LEVEL GROUND THAT IS CAPABLE OF SUPPORTING THE WEIGHT OF BOTH THE **POPSSub** AND THE TOP POLE-MOUNTED ENCLOSURE .

FAILURE TO INSURE A FLAT SURFACE THAT IS CAPABLE OF SUPPORTING THE ENTIRE WEIGHT OF THE **POPSSub** AND **POPS15** MAY RESULT IN INJURY AND PROPERTY DAMAGE!

GAIN

POPSSub has an external gain control designed to match the subwoofer's acoustic output with the **POPS15**. Care should be exercised when setting this gain level to insure that the overall system gain structure is below the system's electronic overload (below clipping levels).

The optimal "starting" point of the **POPSSub**'s gain function is at the 50% rotation position. (half-way between the rotation extremes of the gain function control)

In this position, adding the **POPSSub**'s output to the output of the **POPS15** will increase the low-frequency output at 50 Hz by 6 dB and over 8 dB at 40 Hz. Increasing the gain control to max will produce approximately another 4 dB of output from the 50% position.

Rotating the gain in the counter clockwise direction from the 50% position will rapidly reduce the gain of the **POPSSub**.

The output gain of the mixing console should be set at a low level and then the gain of the **POPSSub** should be set to the desired level to achieve the required overall system acoustic response.

Then the gain of the mixing console should be increased to achieve the desired output levels. If any distortion or clipping is detected, the gain of either the mixing console output or the gain of the **POPS Sub** should be reduced.

The **POPSSub**'s gain control location is shown in the picture below:



POPS Sub Gain

EQUALIZATION

The **POPSSub** has all the required equalization functions included in its amplifier's circuitry. The equalization functions have been optimized for flat frequency response and maximized system dynamics. **POPSSub** does not have user-adjustable external EQ.

The mixing console should be capable of providing sufficient output signal levels to supply the necessary voltage levels to drive the **POPS15** and **POPSSub** to full power and still insure adequate headroom. The mixing console should be capable of driving 100 feet (30.5 m) of balanced cable as well as the **POPS15**.

If additional equalization is required, care should be taken to avoid excessive EQ in any band, but particularly at low frequencies. Excessive equalization can produce "band selective" clipping and distortion. All EQ boost levels should be monitored if system distortion is present.

DISTORTED SOUND

When input levels to the **POPSSub** exceed the amplifier's gain capability, internal dynamics processing functions will engage and provide system protection. However, it is still possible to "overdrive" the input section of the enclosure. If distorted sound is present the following steps should be taken:

1. Verify that the mixer's output is not clipping or overloaded. If the output metering section of the mixing console is continuously in the "red" then the output level should be reduced. (occasional "red" indications are usually fine and are dependent on the mixing console output capability).
2. Verify that excessive equalization is not present anywhere in the signal chain.

3. Verify that AC mains levels are within the required range.



Voltage measurements on the AC Mains should be performed by a licensed electrician or individual trained in making high voltage measurements.

NO SOUND

1. Verify that signal is present on the input of **POPSSub**.
2. Verify that there is AC Mains voltage on the AC Mains input to the **POPSSub**
3. If AC Mains voltage is present, verify that **POPSSub**'s fuse is not blown.



NOTE: IF THE FUSE IS BLOWN, REPLACE ONLY WITH THE SAME TYPE OF FUSE. THIS FUSE TYPE IS NOTED ON THE INPUT PANEL NEAR THE FUSE HOLDER. THE LOCATION OF THE FUSE HOLDER IS SHOWN BELOW.



FUSE HOLDER



The fuse holder is a waterproof design. Insure that the gasket is properly seated when replacing the fuse. Insure that the fuse holder cover is securely tightened. DO NOT OVER-TIGHTEN THE FUSE HOLDER'S COVER.

PRODUCT SERVICE



There are NO user-serviceable parts inside the **POPSSub**. NOTE: See section below titled "Replacement of Components" for woofer servicing.

The **POPSSub's** amplifier module **MUST** be serviced by an individual authorized by One Systems.

POPSSub's amplifier is attached to **POPSSub's** enclosure using 12 x M4 stainless steel machine screws with self-sealing washers. The unique self-sealing feature of these washers forms a waterproof seal between the amplifier module and the enclosure.

The washers are supplied by Gaynor Industries and are Gaynor Industries part number LTN37164

DO NOT SUBSTITUTE WASHER TYPES.

Replacement of Components



REPLACEMENT OF COMPONENTS MUST BE PERFORMED BY A QUALIFIED TECHNICIAN OR ONE KNOWLEDGABLE IN THE REPLACEMENT OF TRANSDUCER COMPONENTS!

DO NOT ATTEMPT ANY REPAIRS UNLESS **POPSSUB'S AMPLIFIER HAS BEEN DISCONNECTED FROM THE AC MAINS SOURCE!**

In the event of woofer failure, the woofer may be accessed by removing the front grill and then removing the woofer. This should be done by a qualified technician or contractor. There is no need to remove the amplifier panel in the event of a woofer failure.



USE EXTREME CARE WHEN HANDLING **POPSSUB'S AMPLIFIER MODULE. THE COMPONENTS ON IT ARE FRAGILE. THE MODULE MUST NOT BE SET ON ITS COMPONENT SIDE OR DAMAGE WILL OCCUR!**