

Installation Instruction Gekave Internal Repair Clamp

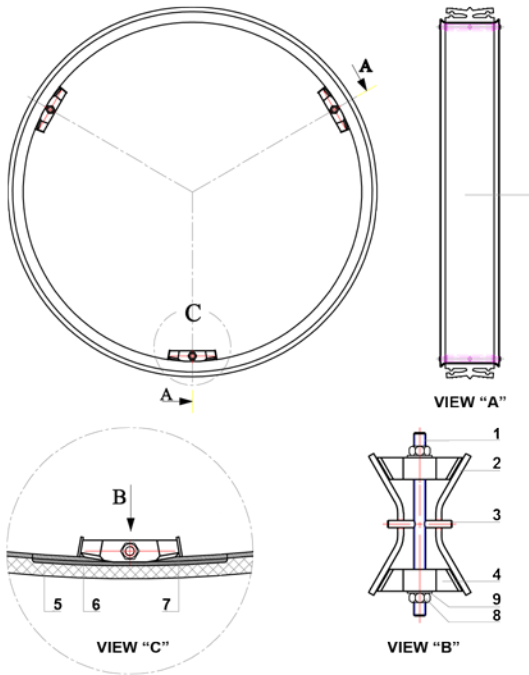

- | | |
|---------------------|--------------|
| 1. Bolt * | 6. Armour |
| 2. Turnbuckle stud | 7. Scale |
| 3. Tension pin * | 8. Nut |
| 4. Turnbuckle block | 9. SS Washer |
| 5. Gasket | |

* 1+3 are connected

IMPORTANT: Always check that you have a correct and fully functional product before you start any excavations or repairs. When in doubt, take a spare unit with you to avoid delaying the work.

GEKAVE

Before installation:

1. Check the internal diameter of the pipe and make sure you are using correctly sized clamps.
2. Clean the pipe to remove as much dirt and corrosion as possible from the surface. Scrape the pipe to remove dirt and corrosion so that the surface is smooth.
3. Make sure no foreign material sticks to the gasket as it is placed in the pipe, nor becomes lodged between gasket and pipe as the nuts are tightened.
4. Keep threads free of foreign material to facilitate tightening.
5. Use a torque wrench to achieve proper torque. Also make sure you use the right wrench size (step 6).
6. Bolts are often not sufficiently tightened if a torque wrench is not used. Take extra care in this situation to ensure proper tightening.

Installation:

Step 1

Mark the pipe where the ends of the clamp will be. After installation use this mark to confirm that the clamp has been properly positioned.

Step 2

Thoroughly clean the pipe surface area to be covered by the clamp. Apply lubricant to pipe and rubber inside the clamp to ensure a proper seal. **DO NOT use grease!**

Step 3

Place the gasket carefully with the grooves against the inside of the pipe. The leakage should be in the middle of the grooves.

Step 4

Place one scale with 2 armours on the bottom of the gasket and install the tension pins/bolts. Place the next scale with 1 armour on one of the tension pins/bolts.

Place the last scale without armours on the other tension pin/bolt and install the last tension pin/bolt.

Step 5

Install all the turnbuckle blocks, SS washers and nuts on the bolts.

Step 6

Then use a torque wrench with a handle of at least 300 mm in length to tighten all nuts evenly and crosswise in 20 Nm increments to a maximum of 140 Nm. This exerts pressure on the bolts so that the sections will expand against the inside of the pipe.

Note: The gap between the turnbuckle blocks should be equal on all turnbuckle studs.

Wrench size:

Recommended torque M16: 140 Nm 24

Always pressure test for leak. If leakage occurs repeat step 4, 5 & 6. Then pressure test again.

Step 6

Wait 20 minutes and then retighten to proper torque.

Note: When installed on plastic pipes, please contact your supplier.



All our quotations, all orders placed with us and all contracts concluded with us are subject to the METAALUNIECONDITIONS, filed with the registrar of the District Court of Rotterdam, as stipulated in the latest text lodged with the said Court. The conditions of delivery and payment have been sent to you earlier and are in your possession, but if they are not, they will be sent to you again upon request. All agreements are subject to the law of the Netherlands.

All disputes arising from offers and agreements, however such disputes may be called, shall be submitted to the competent Dutch Court.