

SOLO-KC

COMPACT GSM DOOR ENTRY UNIT



INSTALLATION MANUAL

Version: Solo_KC_Manual_V1_7-04042013

Valid from SW release: "SOLO v1.0.10 , Rel. Date:20120716".

Contents

1	FOR YOUR SAFETY	6
2	INTRODUCTION	7
3	FEATURES AND APPLICATIONS	8
4	START UP	9
5	LED DISPLAY	10
6	CLEAR ALL PROGRAMMED DATA FROM SIM	11
7	CONNECTING DIAGRAM	12
8	PROGRAMMING SOLO KC	13
9	THE SOLO KC PARAMETERS	14
9.1	ALARM SUPPORT	14
9.2	OUTPUT MANAGEMENT	16
9.3	SECURITY LEVEL - SL.....	17
9.4	PREPAID CARD CREDIT AND VALIDITY INFORMATION.....	19
9.5	SET-UP PARAMETERS.....	21
9.6	INTERCOM.....	25
9.7	CLIP.....	29
9.8	EVENT LOGING	30
9.9	SPECIAL SMS COMMANDS	31
10	PRINT-OUT OF THE PARAMETERS	33
10.1	RECEIVE ALL PARAMETERS (PALL)	33
10.2	CHECK SW REVISION (PSW).....	33
10.3	CHECK SIGNAL QUALITY (PSQ)	33
10.4	RECEIVE TELEPHONE NUMBERS (PTN).....	33
10.5	RECEIVE LINKS (PLN).....	33
10.6	RECEIVE OUTPUT FILTER VALUE (POD).....	33
10.7	RECEIVE ACCESS TELEPHONE NUMBERS (PSL).....	34
10.8	RECEIVE OUTPUT PARAMETERS (POS)	34
10.9	RECEIVE ALL PROGRAMMED SMS MESSAGES (P#)	34
10.10	RECEIVE SET UP PARAMETERS VALUE (PPA)	34
10.11	RECEIVE CREDIT PARS PARAMETERS (PCREF).....	34
10.12	RECEIVE CREDIT PARS PARAMETERS (PCN)	34
10.13	RECEIVE ALL CLIP PARAMETERS (PCLP)	34
10.14	RECEIVE INTERCOM BUTTON 1 PARAMETERS (PDEA)	35
10.15	RECEIVE INTERCOM BUTTON 2 PARAMETERS (PDEB)	35
10.16	RECEIVE INTERCOM BUTTON 3 PARAMETERS (PDEC)	35
10.17	RECEIVE INTERCOM BUTTON 4 PARAMETERS (PDED)	35
10.18	RECEIVE INTERCOM BUTTON 5 PARAMETERS (PDEE).....	35
10.19	RECEIVE INTERCOM BUTTON 6 PARAMETERS (PDEF).....	36
10.20	RECEIVE INTERCOM BUTTON 7 PARAMETERS (PDEG)	36
10.21	RECEIVE INTERCOM BUTTON 8 PARAMETERS (PDEH).....	36

10.22	STATE OF THE CREDIT FOR THE PREPAID CARD	36
10.23	STATE OF THE OUTPUTS (PORC).....	36
10.24	RECEIVE SOLO LOG	37
11	CHANGING PARAMETERS USING THE SMS COMMANDS	38
12	DEFAULT SETTINGS ON SOLO KC.....	39
13	PARAMETERS PRINT-OUT COMMANDS	42
14	TECHNICAL SPECIFICATIONS.....	43
15	CONTACTS	44

Figures

Figure 1: Enclosures options.....	8
Figure 2: SOLO KC Connection diagram.....	12

Tables

Table 1: Remote alarm reporting parameters.....	14
Table 2: Remote alarm reporting example.....	15
Table 3: DTMF control example	15
Table 4: Output management parameters	16
Table 5: Output management parameters example.....	17
Table 6: SL parameter.....	18
Table 7: SL example	18
Table 8: Prepaid card validity parameters.....	20
Table 9: Credit example.....	20
Table 10: Set-up parameters.	23
Table 11: Set-up parameters example.....	24
Table 12: Intercom parameters.	27
Table 13: Intercom parameters example.....	28
Table 14: CLIP parameters.	29
Table 15: CLIP parameters example.....	29
Table 16: LOG parameters.....	30
Table 17: LOG parameters example.	31
Table 18: SMS commands.	32
Table 19: SMS commands example.....	32
Table 20: SOLO default settings.....	41
Table 21: SOLO parameters print out commands.	42

1 FOR YOUR SAFETY

Read these simple guidelines. Not following them may be dangerous or illegal. Read the complete user guide for further information.

SWITCH ON SAFELY

Do not switch the unit on when use of wireless phone is prohibited or when it may cause interference or danger.

INTERFERENCE

All wireless phones and units may be susceptible to interference, which could affect performance.

SWITCH OFF IN HOSPITALS

Follow any restrictions. Switch the unit off near medical equipment.

SWITCH OFF IN AIRCRAFT

Follow any restrictions. Wireless devices can cause interference in aircraft.

SWITCH OFF WHEN REFUELING

Do not use the unit at a refueling point. Do not use near fuel or chemicals.

SWITCH OFF NEAR BLASTING

Follow any restrictions. Do not use the unit where blasting is in progress.

USE SENSIBLY

Use only in the normal position as explained in the product documentation. Do not touch the antenna unnecessarily.

2 INTRODUCTION

SOLO KC is a simple GSM intercom communication system that is designed to ensure low-cost, reliable and single box solution for intercom application. It is designed for unlimited range, wire free GSM intercom and CLIP support.

In addition SOLO KC stay-alive messages, credit detection etc...

3 FEATURES AND APPLICATIONS

Features:

- ⇒ Built-in 4 band GSM module
- ⇒ Up-to 8 buttons call support
- ⇒ 1 output (relay supported)
- ⇒ Up to 100 telephone numbers for CLIP support
- ⇒ Programming by USB SIM Key editor
- ⇒ Programming by USB direct connection
- ⇒ Remote programming by SMS commands

Applications:

- ⇒ Single box, wire free intercom solution
- ⇒ Remote gate opener (CLIP)



Figure 1: Enclosures options

4 START UP

⇒ Insert SIM card to be used for SOLO KC in your personal mobile phone.

IMPORTANT

ERASE THE PIN CODE!

- ⇒ Insert SIM card in SOLO KC device. The unit must be switched OFF when you insert the SIM!
- ⇒ Connect output to SOLO KC.
- ⇒ Connect power cable to SOLO KC device
- ⇒ Connect device to source power supply voltage.
- ⇒ Wait until LED3 (yellow) start flashing in 3s (<1s ON/3s OFF) interval and LED1 (green) starts flashing. This is set in around 1 minute.
- ⇒ SOLO KC unit is now ready to operate.

IMPORTANT

Before sending any SMS commands to SOLO KC device, SOLO KC must be in normal operation!

NOTE

SOLO KC device will “beep” in 15s interval until the device is not in normal operation. When the device goes in normal operation this is notified by 3 “beeps”.

5 LED DISPLAY

GREEN LED (LED1)

- Indicates the level of the GSM signal from 1 to 5 LED flashes (1 is weak signal, 5 is excellent signal)

Red LED (LED2)

- When LED 2 is ON the unit has a problem with a GSM network connection or the GSM part of the unit is out of order. In this case immediately call the service!

Yellow LED (LED3)

- Short flashing indicates that the GSM module is ON, but it is not yet connected on the GSM network. After connection, yellow led is flashing with short pulse ON and a long pulse OFF.

6 CLEAR ALL PROGRAMMED DATA FROM SIM

This is highly recommended when a SIM card you are going to use for the SOLO KC is not new and it already has some data stored in the phone book memory.

By sending this SMS to SOLO KC all programmed parameters and numbers are cleared:
;SDCLR;

After sending SMS you should wait at least 60 second for the command to be executed!

NOTE

By sending this command to the SOLO KC all programmed data are erased from the SIM card, including SMS messages! After the device will start it will be configured with factory defaults.

7 CONNECTING DIAGRAM

Before connection the SOLO KC please take a look at connection diagram.

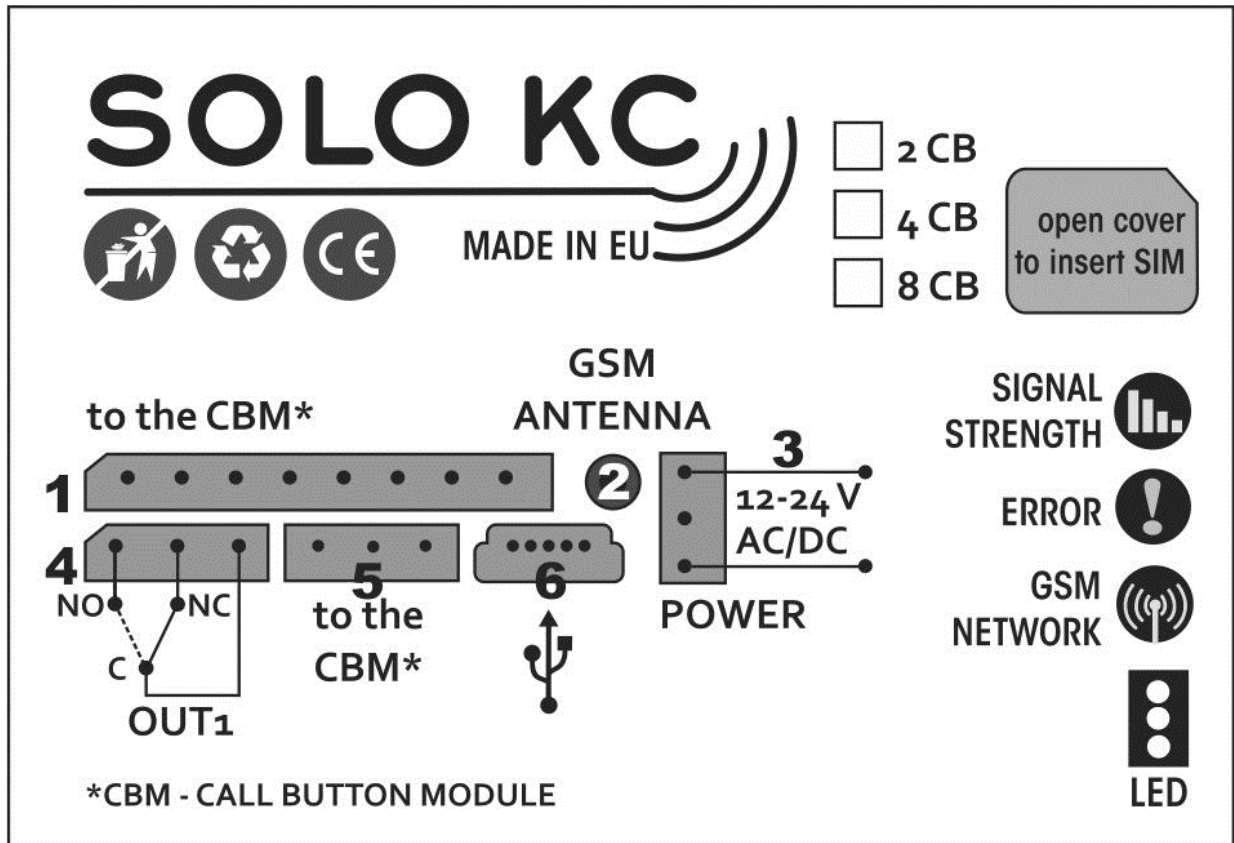

Figure 2: SOLO KC Connection diagram

8 PROGRAMMING SOLO KC

SOLO KC device supports different types of programming:

- ⇒ To program SOLO KC parameters put the SIM card into your personal GSM phone. Add programming parameters in **SIM Card “Phone Book”**.
- ⇒ You can program SOLO KC remotely by SMS command.
- ⇒ You can program SOLO KC with USB key and SIM manager.
- ⇒ You can program SOLO KC with direct USB connection, with the use of configuration software running on PC

NOTE

To receive configuration software for PC please contact your local distributor.

9 THE SOLO KC PARAMETERS

To support versatile functionality of SOLO KC different parameters are used. The parameters are divided in logical sections and are described in the following chapters.

9.1 ALARM SUPPORT

Local generated SOLO KC alarms are being managed by next set of parameters.

Parameters are used to define the way to report the alarm event.

NOTE	SOLO KC device send SMS messages for reporting alarm events.
-------------	--------------------------------------------------------------

9.1.1 TN parameter

Telephone numbers for remote alarm reporting are listed as TN parameters. Remote alarm reporting on SOLO KC is done via SMS messages.

9.1.2 LN parameter

This parameter is used to link alarm event to the telephone numbers from TN list.

9.1.3 Table of parameters

Name	Comment
TN1	1 st telephone number
TN2	2 nd telephone number
TN3	3 rd telephone number
TN4	4 th telephone number
TN5	5 th telephone number
LN5	Periodic test SMS. No. linking (TN1 – TN5)
LN6	SIM card refill. No. linking (TN1 – TN5)
LN7	NAC list. No. linking (TN1 – TN5) (see note)
LN8	Log status. No. linking (TN1 – TN5)

Table 1: Remote alarm reporting parameters

Note:

When telephone number (calling or messaging SOLO KC) is not on the CLIP list, not acknowledge event occurs (NAC). The telephone number responsible for this event will be send to TN user for notification.

Example:

◆ **Direct programming on the SIM card**

SOLO KC PROGRAMMING TABLE		
SIM CARD PHONE BOOK		
Name	Number	Description
TN1	042376678	1st telephone number
LN5	13	Input 1 reports alarm to TN1 & TN3
LN6	1234	Input 2 reports alarm to TN1 & TN2 & TN3 & TN4
LN7	1	NAC event sent to TN1

Table 2: Remote alarm reporting example

◆ **Remote programming by SMS**

;TN1=042376678;LN5=13;LN6=1234;LN7=1;

9.1.4 CONTROLLING OUTPUTS WITH DTMF

SOLO KC can control the outputs with the use of DTMF. This is very useful function in the intercom application.

To control the outputs the user must press the combination of 2 digits. First digit is used to select the output, the second digit is used to activate (1) or deactivate (0) the output. There is a special case when the user can select for first digit (output selection) number 0. In this case all outputs control by the same time.

Combination must be pressed in 2s interval, and must be 3s apart to be valid.

NOTE

SOLO KC must be in voice connection to support DTMF output control!

Example:

DTMF combination	Description
00	Deactivate ALL outputs
01	Activate ALL outputs
11	Activate output 1
10	Deactivate output 1

Table 3: DTMF control example

9.2 OUTPUT MANAGEMENT

SOLO KC supports the possibility to report ongoing functions and any other events locally via 1 output. The behavior is defined using next parameters

9.2.1 OS parameter

SOLO device has 1 dedicated relay supported output. Output can be configured to different behavior:

- ⇒ OS = 0 – Disabled
- ⇒ OS = 1 – Bi-stable toggle mode
- ⇒ OS = xxx – Mono-stable pulse mode (duration in seconds)

9.2.2 OD parameters

OD parameter is used to link the events directly to output.

9.2.3 OP1 parameter

Parameters are used to invert the polarity of the outputs.

- ⇒ 0 – normal
- ⇒ 1 – inverted

9.2.4 Table of parameters

Name	Comment
OS1	Operation mode for output 1
OD5	NAC direct link to output
OD6	Voice active indication
OD7	Button pressed indication
OP1	Invert control for output 1

Table 4: Output management parameters

Example:

◆ **Direct programming on the SIM card**

SOLO KC PROGRAMMING TABLE		
SIM CARD PHONE BOOK		
Name	Number	Description
OS1	1	Bi-stable toggle mode
OS1	14	Mono-stable pulse mode (14s pulse)
OD5	1	NAC event activates output 1
OP1	1	Output 1 inverted

Table 5: Output management parameters example

◆ **Remote programming by SMS**
;OS1=1;OS1=14;OD5=1;OP1=1;

NOTE

SOLO KC has only 1 output, please do not use this output in many functions, because it may result in confusion.

9.3 SECURITY LEVEL - SL

SL parameter from 0 to 5 defines which telephone number stored in the phone book from TN1 – TN5 can enter into programming and remote control of the SOLO KC (dialing the SOLO KC phone number or sending the SMS).

NOTE

When the SL level is 0, an access to the SOLO KC is possible from any phone!

IMPORTANT

Before any SL number is programmed the SOLO KC can accept ALL CALLS. Remote SMS programming and remote controlling is possible from any phone!

Name / value	Comment
SL = 0	All calls and SMS are accepted
SL = 1	Only number stored under parameter TN1 has access to unit
SL = 2	Numbers stored under parameters TN1 to TN2 have access to unit
SL = 3	Numbers stored under parameters TN1 to TN3 have access to unit
SL = 4	Numbers stored under parameters TN1 to TN4 have access to unit
SL = 5	Numbers stored under parameters TN1 to TN5 have access to unit

Table 6: SL parameter

Example:

◆ **Direct programming on the SIM card**

SOLO KC PROGRAMMING TABLE		
SIM CARD PHONE BOOK		
Name	Number	Description
SL	3	Numbers stored under parameters TN1 to TN3 have access to unit

Table 7: SL example

◆ **Remote programming by SMS**

;SL=3;

9.4 PREPAID CARD CREDIT AND VALIDITY INFORMATION

SOLO KC can be used with prepaid SIM cards and its limitations. To be able to overcome this limitation of the prepaid SIM cards, SOLO KC offers the possibility of automatic checking mechanism for credit and time expiration.

NOTE

SOLO KC automatically sends warning SMS when the credit reaches low level defined by LCV parameter or SIM card validity is near to expiration.

NOTE

For support of different GSM providers contact support.

9.4.1 LCV and SCV parameter

LCV is used to set the limit for low credit event. If the credit on prepaid SIM cards falls below this limit SMS is send.

SCV the period of valid operating time varies with different GSM network providers. The value can be programmed from 1 to 360 days. The default value does not presume any kind of expiry warning.

For example in Slovenia SCV are 90 and in Italy 360 days

9.4.2 CC1, CC2 and CC3 parameters

Number used to check low credit value. They are provided from the GSM providers.

- ⇒ CC1 - This method can be used by any GSM provider that supports Unstructured Supplementary Service Data
- ⇒ CC2 - This method is dedicated to Italian TIM mobile provider
- ⇒ CC3 - This method is dedicated to Italian Vodafone mobile provider

9.4.3 CREF, CTIM, CVODA parameters

Parameters are used to find the credit value of the prepaid SIM card. Strings under these parameters are used to pars the replay message from the GSM provider.

- ⇒ CREF - Pars string for the replays received from CC1 number
- ⇒ CVODA - Pars string for the replays received from CC2 number
- ⇒ CTIM - Pars string for the replays received from CC3 number

9.4.4 Table of parameters

Name	Comment
LCV	Low credit value, bottom limit for low credit event.
SCV	SIM card validity time (in days)
CC1	Credit number for credit check universally used
CC2	Credit number for credit check dedicated for Italian TIM mobile provider
CC3	Credit number for credit check dedicated for Italian Vodafone mobile provider
CREP	String for parsing replay message from CC1 number
CVODA	String for parsing replay message from CC2 number
CTIM	String for parsing replay message from CC3 number

Table 8: Prepaid card validity parameters

Example:

◆ Direct programming on the SIM card

SOLO KC PROGRAMMING TABLE		
SIM CARD PHONE BOOK		
Name	Number	Description
CC1	*448#	Si.mobil
CC2	4916	TIM Italy
CC3	404	Vodafone Italy
LCV	4	Low credit message will be send bellow 4

Table 9: Credit example

◆ Remote programming by SMS

;CC1=*448#;CC2=4916;CC3=404;LCV=4;

9.5 SET-UP PARAMETERS

Different parameters are used to support versatile functionality of SOLO KC.

9.5.1 HTN parameter

Hidden telephone number is a parameter used in order to conceal the telephone number of the SOLO KC device. The default value is set to “1” which means that the number is displayed.

9.5.2 UDC parameter

Parameter is used to synchronise SOLO KC clock to GSM network clock. User must enter here the number of the SOLO KC SIM card (Telephone number of SOLO KC device).

9.5.3 RAN parameter

Parameter is used to provide support for auto-answer options for SOLO KC device. The number defines the numbers of rings needed for SOLO KC device to answer the incoming call. The incoming number must be on the TN list for SOLO KC device to answer.

NOTE

If auto-answer function is enabled and same telephone number is on TNx list and CLIP list, than this number will be used in CLIP function. CLIP function has priority over auto-answer function.

9.5.4 TST parameter

A test SMS is sent periodically. SOLO KC can send the test message in the interval ranging from 1 hour to 240 hours.

Example:

To send test SMS TST value is set to 12, the numbers linked to “LN5” receive a test message every 12 hours.

9.5.5 TSTT parameter

TSTT parameter is used to define reference point for sending test message. If this parameter is set than after restart of the ZEUS4-MC first test SMS will be send out at time defined with TSTT parameter.

Parameter value is defined in hours.

Example:

To receive first test SMS at 20.00h TSTT value must be set to 20

NOTE

By setting TSTT=0 this function is disabled

9.5.6 MNF parameter

When it is necessary to fix the GSM network to one provider the user can use the MNF parameter. The MNF parameter switches automatic network searching to manual.

Example:

MCC/MNC code for Si.mobil is 29340, Mobitel is 29341, TIM is 22201, and Vodafone Italy is 22210.

More information about national MCC/MNC codes can be acquired at:

http://en.wikipedia.org/wiki/Mobile_Network_Code

9.5.7 MIC parameter

MIC parameter enables you to change the sound level on microphone

9.5.8 SPK parameter

SPK parameter enables you to change the speaker sound level.

9.5.9 MUT parameter

MUT parameter enables you mutates the speaker sound while initiating voice connection.

9.5.10 ARST parameter

ARST parameter defines periodic of auto restart time (in hours) of the SOLO KC device.

9.5.11 ADF parameter

Parameter is used to define voice refresh function, to prevent blocking of SIM in some networks.

9.5.12 LNG parameter

LNG parameter switches between the preprogrammed languages:

- ⇒ 0 - English
- ⇒ 1 - Italian
- ⇒ 2 - Slovenian
- ⇒ 3 - Croatian
- ⇒ 4 - Dutch
- ⇒ 5 - German
- ⇒ 6 - Spanish

9.5.13 BUZ parameter

Parameter is used to control buzzer functionality on SOLO KC. Buzzer is used to audio support some events on SOLO KC device

9.5.1 SPO parameter

Parameter is used to define the starting point on the SIM card from where toward the parameters are written.

NOTE

This parameter is only used when programming is done via SMS or directly over USB connection. This parameter must be send first before other parameters.

9.5.2 LOT parameter

LOT parameter is used to define the time out control for voice calls. The start of voice connection starts the LOT timer. If the voice connection is still ON when the LOT timer expires SOLO KC disconnects ongoing voice connection.

9.5.3 #0 parameter

Parameter is used to define head of the SMS message. It is used by the user to uniquely define the name of the SOLO KC device. This name will be put in front of every SMS the user will receive.

NOTE

The text for a name if written together with the parameter name.
Example: #0DEMO

9.5.4 Table of parameters

Name	Comment
UDC	Tel. number of SOL KC device
RAN	Auto answer ring number
HTN	Hidden telephone number
TST	SMS test time out
TSTT	Periodic test SMS start time
MNF	Manual GSM provider selection
MIC	Microphone volume control
SPK	Speaker volume control
ARST	Time out control for automatic system restart
ADF	Auto dial functionality (Call TN1)
LNG	Language selection
BUZ	Buzzer control
LOT	Voice time out control
#0	Unique name for SMS reporting

Table 10: Set-up parameters.

Example:

◆ **Direct programming on the SIM card**

SOLO KC PROGRAMMING TABLE		
SIM CARD PHONE BOOK		
Name	Number	Description
HTN	0	Hidden telephone number of the SOLO KC device
MNF	29340	Manual fixing of the GSM provider (Si.mobil)
LNG	1	Switch on Italian language
MIC	2	Microphone volume level
SPK	20	Speaker volume level
TST	24	24 hours periodic test SMS
BUZ	0	Mute buzzer
LOT	50	Voice connection will be terminated after 50s
#0HOUSE1	1	SOLO KC name

Table 11: Set-up parameters example.

◆ **Remote programming by SMS**

;HTN=0;MNF=29340;LNG=1;MIC=2;SPK=20;TST=24;BUZ=0;LOT=50;
;#0HOUSE1=1;

9.6 INTERCOM

Intercom functionality is supported by a set of parameters, used to tweak the functionality to each user needs.

For each button SOLO KC incorporates a group of parameters. There are up to 8 groups of parameters.

9.6.1 xTN1 to xTN5 parameters

Parameters are the call numbers for intercom application.

9.6.2 RTNx parameter

Parameter defines the ring time time-out. RTNx timer is started when the call button is pressed. If the RTNx timer expires before the GSM voice connection is established then SOLO KC device calls the next number in xTN1-xTN5 call list.

NOTE

When the button is pressed the call is first made to the 1st telephone number on the list, if the user under 1st telephone number on the list does not answer the call then the call is made to 2nd number if this user answers the call, then SOLO KC will not call further numbers.

9.6.3 DTMF auto dial functionality

This function is used to provide a support for SOLO KC device to be able select extended numbers via DTMF command.

9.6.3.1 SDNx parameter

Parameter is used to set the DTMF number in auto self select function.

9.6.3.2 SDDx parameter

Parameter is used to set the delay (in s) for sending DTMF number in auto self select function.

NOTE

After the voice connection is established the SOLO KC will send out SDNx DTMF number, after SDDx time out time. Useful function for automatic extension selection.

9.6.4 Time zone

Time zone supported when both time limits are set (TZSx and TZEx). When the current time is in the limits of the time zone parameters the button event calls the number from xTN1 to xTN4, else button event calls xTN5.

9.6.4.1 TZSx parameter

Parameter is used to configure the start time for the time zone functionality - 24h time format.

9.6.4.2 TZEx parameter

Parameter is used to configure the end time for the time zone functionality - 24h time format.

9.6.5 Table of parameters

Name	Comment
ATN1	Button 1, Telephone number 1.
ATN2	Button 1, Telephone number 2.
ATN3	Button 1, Telephone number 3.
ATN4	Button 1, Telephone number 4.
ATN5	Button 1, Telephone number 5.
RTNA	Button 1, time out control for voice connection.
SDNA	Button 1, DTMF number to send.
SDDA	Button 1, delay for DTMF number to send.
TZSA	Button 1, time zone start period.
TZEA	Button 1, time zone end period.
BTN1	Button 2, Telephone number 1.
BTN2	Button 2, Telephone number 2.
BTN3	Button 2, Telephone number 3.
BTN4	Button 2, Telephone number 4.
BTN5	Button 2, Telephone number 5.
RTNB	Button 2, time out control for voice connection.
SDNB	Button 2, DTMF number to send.
Sddb	Button 2, delay for DTMF number to send.
TZSB	Button 2, time zone start period.
TZEB	Button 2, time zone end period.
CTN1	Button 3, Telephone number 1.
CTN2	Button 3, Telephone number 2.
CTN3	Button 3, Telephone number 3.
CTN4	Button 3, Telephone number 4.
CTN5	Button 3, Telephone number 5.
RTNC	Button 3, time out control for voice connection.
SDNC	Button 3, DTMF number to send.
SDDC	Button 3, delay for DTMF number to send.
TZSC	Button 3, time zone start period.
TZEC	Button 3, time zone end period.
DTN1	Button 4, Telephone number 1.
DTN2	Button 4, Telephone number 2.

Name	Comment
DTN3	Button 4, Telephone number 3.
DTN4	Button 4, Telephone number 4.
DTN5	Button 4, Telephone number 5.
RTND	Button 4, time out control for voice connection.
SDND	Button 4, DTMF number to send.
SDDD	Button 4, delay for DTMF number to send.
TZSD	Button 4, time zone start period.
TZED	Button 4, time zone end period.
ETN1	Button 5, Telephone number 1.
ETN2	Button 5, Telephone number 2.
ETN3	Button 5, Telephone number 3.
ETN4	Button 5, Telephone number 4.
ETN5	Button 5, Telephone number 5.
RTNE	Button 5, time out control for voice connection.
SDNE	Button 5, DTMF number to send.
SDDE	Button 5, delay for DTMF number to send.
TZSE	Button 5, time zone start period.
TZEE	Button 5, time zone end period.
FTN1	Button 6, Telephone number 1.
FTN2	Button 6, Telephone number 2.
FTN3	Button 6, Telephone number 3.
FTN4	Button 6, Telephone number 4.
FTN5	Button 6, Telephone number 5.
RTNF	Button 6, time out control for voice connection
SDNE	Button 6, DTMF number to send.
SDDE	Button 6, delay for DTMF number to send.
TZSE	Button 6, time zone start period.
TZEE	Button 6, time zone end period.
GTN1	Button 7, Telephone number 1.
GTN2	Button 7, Telephone number 2.
GTN3	Button 7, Telephone number 3.
GTN4	Button 7, Telephone number 4.
GTN5	Button 7, Telephone number 5.
RTNG	Button 7, time out control for voice connection
SDNG	Button 7, DTMF number to send.
SDDG	Button 7, delay for DTMF number to send.
TZSG	Button 7, time zone start period.
TZEG	Button 7, time zone end period.
HTN1	Button 8, Telephone number 1.
HTN2	Button 8, Telephone number 2.
HTN3	Button 8, Telephone number 3.
HTN4	Button 8, Telephone number 4.
HTN5	Button 8, Telephone number 5.
RTNH	Button 8, time out control for voice connection
SDNH	Button 8, DTMF number to send.
SDDH	Button 8, delay for DTMF number to send.
TZSH	Button 8, time zone start period.
TZEH	Button 8, time zone end period.

Table 12: Intercom parameters.

Example:

◆ **Direct programming on the SIM card**

SOLO KC PROGRAMMING TABLE		
SIM CARD PHONE BOOK		
Name	Number	Description
ATN1	040713470	Button 1, Telephone number 1.
ATN2	+38643364850	Button 1, Telephone number 2.
RTNA	30	Button 1, time out control for voice connection.
CTN1	040414414	Button 3, Telephone number 1.
CNT2	042340880	Button 3, Telephone number 1.
RTNC	40	Button 3, time out control for voice connection.

Table 13: Intercom parameters example.

◆ **Remote programming by SMS**

;ATN1=040713470;ATN2=+38643364850;RTNA=30;CTN1=040414414;CTN2=042340880;RTNC=40;

9.7 CLIP

CLIP is used to provide the “free of charge” options to control the outputs.

9.7.1 CLPEN parameter

Parameter used to enable CLIP functionality.

9.7.2 CLPOU parameter

Parameter used to choose which output will be controlled by the CLIP functionality.

9.7.3 CLP1 ... CLP100 parameter

Set of telephone number, which can control the output. The number not on CLP list is not able to control the output using clip functionality.

9.7.4 Table of parameters

Name	Comment
CLPEN	Enable CLIP functionality
CLPOU	Control output pin when CLIP event
CLPI	CLIP input activation condition
CLP1	CLIP number 1
.	.
.	.
.	.
CLP100	CLIP number 100

Table 14: CLIP parameters.

Example:

◆ Direct programming on the SIM card

SOLO KC PROGRAMMING TABLE		
SIM CARD PHONE BOOK		
Name	Number	Description
CLPEN	1	Enable CLIP functionality
CLPOU	1	CLIP control output 1
CLP1	040414414	CLIP number 1
CLP2	042340880	CLIP number 2

Table 15: CLIP parameters example.

◆ Remote programming by SMS

;CLPEN=1;CLPOU=2;CLP1=040414414;CLP2=042340880;

9.8 EVENT LOGGING

SOLO KC device support logging of specific events. SOLO KC logs CLIP event. Log event consist of event type, time and telephone number or input number.

9.8.1 LOGN parameter

Parameter is used for defining the number of events printed out on PLOG request.

9.8.2 LOGI parameter

Parameter is used to define the media used for logging of events on SOLO. User can select between nonvolatile memories on SOLO KC or select USB to transfer events directly via USB to PC.

- ⇒ LOGI=0 Logging is OFF
- ⇒ LOGI=1 Logging in internal memory
- ⇒ LOGI=2 Logging to USB interface

9.8.3 ALC parameter

Parameter is used to control behavior when log on SOLO KC is full. User can select between auto log clear or manual clear of log.

- ⇒ ALC=0 Automatically delete buffer when memory is FULL
- ⇒ ALC=1 Memory buffer must be deleted manually when it is FULL

9.8.4 Table of parameters

Name	Comment
LOGN	Number of log events for printing out
LOGI	Log interface
ALC	Automatic log clear

Table 16: LOG parameters.

Example:

◆ **Direct programming on the SIM card**

SOLO KC PROGRAMMING TABLE		
SIM CARD PHONE BOOK		
Name	Number	Description
LOGN	5	5 log events will be printed out on PLOG command
LOGI	0	No logging of the events
ALC	1	Log is auto cleared when full

Table 17: LOG parameters example.

◆ **Remote programming by SMS**

;LOGN=5;LOGI=0;ALC=1;

9.9 SPECIAL SMS COMMANDS

These commands can only be issued only over SMS message, and are used to control some special functions of SOLO KC device.

9.9.1 ORC command

Command is used to control outputs directly via SMS message

9.9.2 SDCLR command

SDCLR command is used to delete all parameters and SMS on SIM card. After delete process is completed the system will be restarted. Now SOLO KC will be loaded with factory default settings.

9.9.3 LCRL command

Command clears log on SOLO KC device.

9.9.4 CLPCLR command

Command is used to delete all CLP numbers.

9.9.5 MRES command

Command is used to manually restart GSM module on SOLO KC device.

9.9.6 SSRES command

Command is used to manually restart SOLO KC device.

9.9.7 Table of parameters

Name	Comment
ORC1	Control of output 1
ORC2	Control of output 2
SDCLR	Delete all SIM content
LCRL	Delete log on SOLO KC device
MRES	Manual reset of GSM module
SSRES	Manual reset of SOLO device

Table 18: SMS commands.

Example:

◆ Remote programming by SMS

SMS commad	Description
;ORC1=1;	Activate output 1
;ORC2=0;	Deactivate output 2
;SDCLR;	Clear all data on SIM
;LCLR;	Delete log on SOLO KC device
;MRES;	Manual reset of GSM module
;SSRES;	Manual reset of SOLO KC device

Table 19: SMS commands example.

10 PRINT-OUT OF THE PARAMETERS

The user can check the settings of ALL parameters on the SOLO KC.

10.1 RECEIVE ALL PARAMETERS (PALL)

By sending this command to SOLO KC you receive SMS messages with all parameters that are currently programmed in the unit:

;PALL;

10.2 CHECK SW REVISION (PSW)

By sending this command to SOLO KC you receive SMS messages with current SW version running on SOLO KC device:

;PSW;

10.3 CHECK SIGNAL QUALITY (PSQ)

By sending this command to SOLO KC you receive SMS messages with signal quality SOLO KC device is connected to network:

;PSQ;

10.4 RECEIVE TELEPHONE NUMBERS (PTN)

By sending this command to SOLO KC you receive SMS message with all currently programmed telephone numbers (TN1 – TN5):

;PTN;

10.5 RECEIVE LINKS (PLN)

By sending this command to SOLO KC you receive SMS message with all currently programmed links (LN5 –LN8):

;PLN;

10.6 RECEIVE OUTPUT FILTER VALUE (POD)

By sending this command to SOLO KC you receive SMS message with all currently programmed direct output links (OD5 – OD7):

;POD;

10.7 RECEIVE ACCESS TELEPHONE NUMBERS (PSL)

By sending this command to SOLO KC you receive SMS message with programmed SL level:
;PSL;

10.8 RECEIVE OUTPUT PARAMETERS (POS)

By sending this command to SOLO KC you receive SMS message with all currently programmed Outputs parameters (OS1):
;POS;

10.9 RECEIVE ALL PROGRAMMED SMS MESSAGES (P#)

By sending this command to SOLO KC you receive SMS message with all currently programmed alarm SMS messages (#0):
;P#;

10.10 RECEIVE SET UP PARAMETERS VALUE (PPA)

By sending this command to SOLO KC you receive SMS message with all currently programmed Setup parameters (TST, MNF...):
;PPA;

10.11 RECEIVE CREDIT PARS PARAMETERS (PCREF)

By sending this command to SOLO KC you receive SMS message with all currently programmed credit parse parameters (CREF, CVODA...):
;PCREF;

10.12 RECEIVE CREDIT PARS PARAMETERS (PCN)

By sending this command to SOLO KC you receive SMS message with all currently programmed credit check number (CC1, CC2, CC3):
;PCN;

10.13 RECEIVE ALL CLIP PARAMETERS (PCLP)

By sending this command to SOLO KC you receive SMS message with all currently programmed CLIP functionality related parameters (CLPEN, CLPOU, CLPx):
;PCLP;

NOTE

User can use ;PCLP=x,y; to limit the number of CLIP numbers to be printed.
x = start number
y = end number
Example
;PCLP=1,30; Prints first 30 CLIP numbers

10.14 RECEIVE INTERCOM BUTTON 1 PARAMETERS (PDEA)

By sending this command to SOLO KC you receive SMS message with all currently programmed button 1 group parameters (ATN1, ATN2, ATN3, ATN4, ATN5, RTNA, SDNA, SDDA, TZSA, TZEA):

;PDEA;

10.15 RECEIVE INTERCOM BUTTON 2 PARAMETERS (PDEB)

By sending this command to SOLO KC you receive SMS message with all currently programmed button 2 group parameters (BTN1, BTN2, BTN3, BTN4, BTN5, RTNB, SDNB, SDDB, TZSB, TZEB):

;PDEB;

10.16 RECEIVE INTERCOM BUTTON 3 PARAMETERS (PDEC)

By sending this command to SOLO KC you receive SMS message with all currently programmed button 3 group parameters (CTN1, CTN2, CTN3, CTN4, CTN5, RTNC, SDNC, SDDC, TZSC, TZEC):

;PDEC;

10.17 RECEIVE INTERCOM BUTTON 4 PARAMETERS (PDED)

By sending this command to SOLO KC you receive SMS message with all currently programmed button 4 group parameters (DTN1, DTN2, DTN3, DTN4, DTN5, RTND, SDND, SDDD, TZSD, TZED):

;PDED;

10.18 RECEIVE INTERCOM BUTTON 5 PARAMETERS (PDEE)

By sending this command to SOLO KC you receive SMS message with all currently programmed button 5 group parameters (ETN1, ETN2, ETN3, ETN4, ETN5, RTNE, SDNE, SDDE, TZSE, TZEE):

;PDEE;

10.19 RECEIVE INTERCOM BUTTON 6 PARAMETERS (PDEF)

By sending this command to SOLO KC you receive SMS message with all currently programmed button 6 group parameters (FTN1, FTN2, FTN3, FTN4, FTN5, RTNF, SDNF, SDDF, TZSF, TZEF):

;PDEF;

10.20 RECEIVE INTERCOM BUTTON 7 PARAMETERS (PDEG)

By sending this command to SOLO KC you receive SMS message with all currently programmed button 7 group parameters (GTN1, GTN2, GTN3, GTN4, GTN5, RTNG, SDNG, SDDG, TZSG, TZEG):

;PDEG;

10.21 RECEIVE INTERCOM BUTTON 8 PARAMETERS (PDEH)

By sending this command to SOLO KC you receive SMS message with all currently programmed button 8 group parameters (HTN1, HTN2, HTN3, HTN4, HTN5, RTNH, SDNH, SDDH, TZSH, TZEH):

;PDEH;

10.22 STATE OF THE CREDIT FOR THE PREPAID CARD

By sending this command to SOLO KC you receive SMS message with Credit amount on your prepaid SIM card:

;PCCx;

Where x is the number of programmed prepaid function in use.

10.23 STATE OF THE OUTPUTS (PORC)

By sending this command to SOLO KC you receive SMS message with current outputs state.

;PORC;

10.24 RECEIVE SOLO LOG

By sending this command to SOLO KC you receive SMS message with log on SOLO device.
;PLOG;

NOTE

User can use ;PLOG=x,y; to define the number of logs to be printed.

x = start event

y = end event

Example

;PLOG=1, 30; Prints first 30 log events

11 CHANGING PARAMETERS USING THE SMS COMMANDS

All programming parameters for SOLO KC can also be sent by SMS command. Each SMS command should start and stop with semicolon. If the confirmation SMS is needed, put “+” at the beginning of the command SMS.

NOTE

Use “+” only with configuration commands, not with print out commands.

If you would like to check which telephone numbers are programmed in SOLO KC please use the following command:

;PTN;

Return SMS is (example):

;TN1=0;TN2=0;

If you would like to enter telephone numbers in to SOLO KC you can use the following example:

;TN1=040713470;TN2=+38643364850;

If you would like to receive confirmation SMS write “+” before SMS command:

;+TN1=040713470;TN2=+38643364850;

Return SMS from SOLO KC is:

;TN1=040713470;TN2=+38643364850;

NOTE

You can use the same programming procedure for all parameters.

It is also possible to change different parameters with one SMS. Consider that the SMS message should not be longer than **160 characters** (included space characters).

If you would like to change the following parameters **TN1, OS1, OS2, LN1** and would like to receive confirmation SMS, try next example:

;+TN1=+38640713470;OS1=15;LN1=1;

Send SMS message to SOLO KC telephone number and in a few seconds you receive SMS message from SOLO KC.

12 DEFAULT SETTINGS ON SOLO KC

SOLO PROGRAMMING TABLE		
Name	Default Value	Short Description
TN1	Empty	Telephone number 1
TN2	Empty	Telephone number 1
TN3	Empty	Telephone number 2
TN4	Empty	Telephone number 3
TN5	Empty	Telephone number 4
OS1	5	Output 1 mode
OD5	0	NAC indication
OD6	0	Voice active indication
OD7	0	Call button pressed indication
LN5	Empty	Periodic SMS text, link to tel. numbers
LN6	Empty	SIM card refill, link to tel. numbers
LN7	Empty	NAC, link to tel. numbers
LN8	Empty	LOG full, link to tel. numbers
SL	0	Security level
#0	“User Location”	SMS main head text
CC1	Empty	Check credit Num 1
CC2	Empty	Check credit, TIM Italy
CC3	Empty	Check credit, Vodafone Italy
UDC	Empty	Tel. number of SOLO device
HTN	1	Hidden telephone number
RAN	0	Auto answer ring number
SCV	0	SIM card time validity
TST	24	Periodic test SMS timeout
TSTT	0	Periodic test SMS start time
MNF	0	Network connection type
MIC	15	Microphone volume setting (0 - 40)
MUT	0	Mute functionality
SPK	10	Speaker volume setting (0 - 20)
LCV	4	Low credit value
LNG	0	Language selection
LOT	90	Connection time out value
LOGN	5	Number of log events for printing out
LOGI	0	Log interface
ALC	1	Automatic log clear
ADF	90	Auto dial functionality (Call TN1)
ARST	0	Automatic reset timeout
CREF	“EUR”	Parse text(contact support)
CTIM	“EURO”	Parse text(contact support)
CVODA	“E”	Parse text(contact support)
OP1	0	Output invert 1

SOLO PROGRAMMING TABLE		
Name	Default Value	Short Description
BUZ	1	Buzzer control
SPO	1	SIM card starting position
CLPEN	1	Enable CLIP functionality
CLPOU	1	Control output pin when CLIP event
CLP1	Empty	CLIP number 1
.	.	
CLP100	Empty	CLIP number 100
ATN1	Empty	Button 1, Telephone number 1
ATN2	Empty	Button 1, Telephone number 2
ATN3	Empty	Button 1, Telephone number 3
ATN4	Empty	Button 1, Telephone number 4
ATN5	Empty	Button 1, Telephone number 5
RTNA	25	Ring time, Button 1
SDNA	0	DTMF number to send
SDDA	0	Delay for DTMF to send
TZSA	0	Time zone start interval
TZEA	0	Time zone end interval
BTN1	Empty	Button 2, Telephone number 1
BTN2	Empty	Button 2, Telephone number 2
BTN3	Empty	Button 2, Telephone number 3
BTN4	Empty	Button 2, Telephone number 4
BTN5	Empty	Button 2, Telephone number 5
RTNB	25	Ring time, Button 2
SDNB	0	DTMF number to send
SDDB	0	Delay for DTMF to send
TZSB	0	Time zone start interval
TZEB	0	Time zone end interval
CTN1	Empty	Button 3, Telephone number 1
CTN2	Empty	Button 3, Telephone number 2
CTN3	Empty	Button 3, Telephone number 3
CTN4	Empty	Button 3, Telephone number 4
CTN5	Empty	Switch 3, Telephone number 5
RTNC	25	Ring time, Button 3
SDNC	0	DTMF number to send
SDDC	0	Delay for DTMF to send
TZSC	0	Time zone start interval
TZEC	0	Time zone end interval
DTN1	Empty	Button 4, Telephone number 1
DTN2	Empty	Button 4, Telephone number 2
DTN3	Empty	Button 4, Telephone number 3
DTN4	Empty	Button 4, Telephone number 4
DTN5	Empty	Button 4, Telephone number 5
RTND	25	Ring time, Button 4
SDND	0	DTMF number to send

SOLO PROGRAMMING TABLE		
Name	Default Value	Short Description
SDDD	0	Delay for DTMF to send
TZSD	0	Time zone start interval
TZED	0	Time zone end interval
ETN1	Empty	Button 5, Telephone number 1
ETN2	Empty	Button 5, Telephone number 2
ETN3	Empty	Button , Telephone number 3
ETN4	Empty	Button 5, Telephone number 4
ETN5	Empty	Button 5, Telephone number 5
RTNE	25	Ring time, Button 5
SDNE	0	DTMF number to send
SDDE	0	Delay for DTMF to send
TZSE	0	Time zone start interval
TZEE	0	Time zone end interval
FTN1	Empty	Button 6, Telephone number 1
FTN2	Empty	Button 6, Telephone number 2
FTN3	Empty	Button 6, Telephone number 3
FTN4	Empty	Button 6, Telephone number 4
FTN5	Empty	Button 6, Telephone number 5
RTNF	25	Ring time, Button 6
SDNF	0	DTMF number to send
SDDF	0	Delay for DTMF to send
TZSF	0	Time zone start interval
TZEF	0	Time zone end interval
GTN1	Empty	Button 7, Telephone number 1
GTN2	Empty	Button 7, Telephone number 2
GTN3	Empty	Button 7, Telephone number 3
GTN4	Empty	Button 7, Telephone number 4
GTN5	Empty	Switch 7, Telephone number 5
RTNG	25	Ring time, Button 7
SDNG	0	DTMF number to send
SDDG	0	Delay for DTMF to send
TZSG	0	Time zone start interval
TZEG	0	Time zone end interval
HTN1	Empty	Button 8, Telephone number 1
HTN2	Empty	Button 8, Telephone number 2
HTN3	Empty	Button 8, Telephone number 3
HTN4	Empty	Button 8, Telephone number 4
HTN5	Empty	Button 8, Telephone number 5
RTNH	25	Ring time, Button 8
SDNH	0	DTMF number to send
SDDH	0	Delay for DTMF to send
TZSH	0	Time zone start interval
TZEH	0	Time zone end interval

Table 20: SOLO default settings.

13 PARAMETERS PRINT-OUT COMMANDS

SOLO PROGRAMMING TABLE	
Name	Short Description
PALL	Prints all parameters available on SOLO.
PSW	Prints SW version of SOLO.
PSQ	Prints GSM network signal quality of SOLO.
PTN	Prints TNx numbers.
PLN	Prints LNx links.
POD	Prints ODx parameters.
PSL	Prints SL parameter.
POS	Prints OSx parameters.
P#	Prints #x parameters.
PPA	Prints various setup parameters.
PCLP	Prints CLIP parameters.
PLOG	Prints log of the SOLO.
PCREF	Prints credit pars parameters.
PCN	Prints credit request numbers.
PCC1	Prints credit for SOLO (universal request).
PCC2	Prints credit for SOLO. (TIM Italy).
PCC3	Prints credit for SOLO. (VODAFONE Italy).
PORC	Prints (controls) the status of outputs.
PDEA	Prints intercom button 1 parameters.
PDEB	Prints intercom button 2 parameters.
PDEC	Prints intercom button 3 parameters.
PDED	Prints intercom button 4 parameters.
PDEE	Prints intercom button 5 parameters.
PDEF	Prints intercom button 6 parameters.
PDEG	Prints intercom button 7 parameters.
PDEH	Prints intercom button 8 parameters.
PERR	Special debug command, contact supplier for details.

Table 21: SOLO parameters print out commands.

14 TECHNICAL SPECIFICATIONS

Description	Value
Power Supply	12 - 24V AC/DC
Current consumption - peak	2A
Current consumption - transmitting mode	250mA
Current consumption - idle mode	40mA
Quad band GSM module (Cinterion)	850/900/1800/1900 MHz
PCB dimensions	91 × 82 mm
Unit dimensions	220 × 125 × 30 mm
Call buttons	Up to 8
Built-in Antenna SMA	1
Weight	470 g
Alarm inputs	/
Alarm outputs (relay)	1
12V DC Power Supply input	Yes
12-24V AC/DC Power Supply input	Yes

15 CONTACTS

MARS COMMERCE d.o.o.

MIRKA VADNOVA 19
4000 KRANJ
SLOVENIA

TEL: + 386 4 280 74 00

E-MAIL: info@mars-commerce.si

WEB SITE: www.mars-commerce.com

SALES

E-MAIL: sales@mars-commerce.com

TEL: +386 4 280 74 06