

Installation Manual

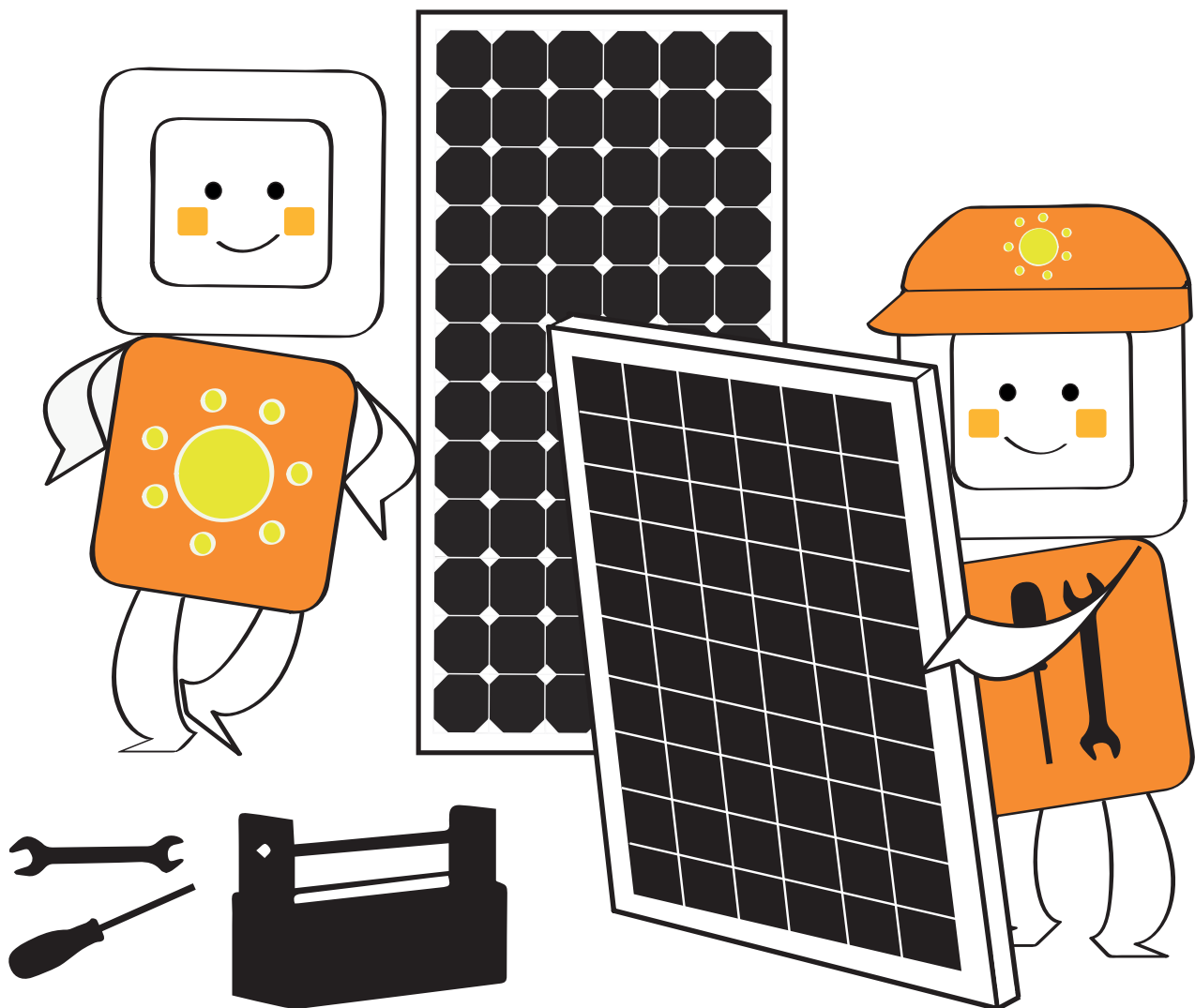

Monocrystalline Modules and Polycrystalline Modules

This manual contains information regarding the safe installation and handling of photovoltaic modules produced by ZNSHINE PV-Tech Co., Ltd. ("ZNSHINE SOLAR"). All the instructions provided in this manual should be read carefully and understood before attempting to install the modules. Please contact ZNSHINE SOLAR Customer Service for further explanation.

These instructions are intended for dealers and installers involved in the planning, installation and commissioning of photovoltaic systems with polycrystalline or monocrystalline solar modules by ZNSHINE SOLAR. They are meant to provide you with valuable information to ensure a smooth and correct installation of ZNSHINE SOLAR modules. ZNSHINE SOLAR modules are made of carefully selected materials. They are tested and approved by acknowledged independent certification authorities and may only be installed by qualified professional companies. Please observe the standards and regulations applying to photovoltaic systems in the relevant countries, as well as the rules of the employers' liability insurance associations for accident protection. Failure to comply with these can result in major injuries and damage.

Specifications and assembly instructions from this installation guide are based on the standards applicable in Europe. Special conditions should always be clarified by an expert so that the roof requirements as well as other individual requirements are duly taken into account. Keep these installation instructions in a safe place!

Overview

1. Product Identification pag. 2
2. Safety pag. 2
2.1 General Safety	
2.2 Handling Safety	
2.3 Installation Safety	
2.4 Fire Safety	
3. Installation pag. 5
3.1 Mechanical Installation pag. 6
3.1.1 Installations Using Frame Mounting Holes	
3.1.2 Installations Using Pressure Clamps	
3.1.3 Insertion Systems	
3.1.4 Module Resistance	
3.2 Electrical Installation pag. 10
3.2.1 General Considerations	
3.2.2 System Grounding	
4. Maintenance pag. 13
4.1 General Maintenance	
4.2 Cleaning	
5. Module End of Life pag. 14
6. Module Specification pag. 15

7. Disclaimer of Liability pag. 16
8. Contact Information pag. 16
Annex 1 pag. 17
Installations Using Frame Mounting Holes	
Installations Using Pressure Clamps	
Insertion Systems	

1. Product Identification

Each module can be identified by means of the following embedded information:

Nameplate: it is to be found on the module backside. According to EN 50380 Directives it provides information about the main parameters of the module: Product Type, Maximum Power, Current at Maximum Power, Voltage at Maximum power, Open Circuit Voltage, Short Circuit Current, all as measured under Standard Test Conditions, weight, dimensions, Maximum System Voltage, Maximum series fuse etc.

Serial number: each individual module is identified by a unique serial number coupled with a barcode. They are permanently inserted inside the laminate, under the front glass of the module, visible when viewing from the front of the module. There is only one serial number coupled with one barcode on the module.

2. Safety

2.1 General Safety

All PV modules shall be installed according to all local and national applicable standards, codes and regulations. Installation should be performed only by qualified persons. The installators bear the risk of all injury that might occur during installation including, without limitation, the risk of electric shock. Check and follow all safety precautions specified even for the other components of the system.



- Rooftop installations should be placed over fire resistant roofs only.
- Do not attempt to disassemble the modules, and do not remove any attached nameplates or components from the modules.
- Do not apply paint or adhesive to module top surface.
- Do not use mirrors or other magnifiers to artificially concentrate sunlight on the modules.
- Do not expose back sheet foils directly to sunlight.

2.2 Handling Safety



- Do not exceed the maximum height of pallets stacked on top of each other. Maximum height is 2 pallets (standard packaging for shipment).
- Do not damage or scratch the PV module surfaces.
- Do not use the junction boxes and the cables as a grip.
- Do not stand or step on module.
- Do not drop module or allow objects to fall on module.
- To avoid glass breakage, do not place any heavy objects on the module.
- Do not set the module down hard on any surface.
- Inappropriate transport and installation may break module.



FRAGILE



**HANDLE
WITH CARE**



DO NOT STEP



**STACKING
LIMITATION**

2.3 Installation Safety



Installing solar photovoltaic systems requires specialized skills and knowledge. One individual module may generate DC voltages greater than 30 V when exposed to light of any intensity. Contact with a DC voltage of 30 V or more is potentially hazardous. Series or parallel connection of the modules increases the voltage or electric current respectively.

- Do not disconnect modules under load to avoid electrical arcs. Keep connectors dry and clean
- Do not insert electrically conductive parts into the plugs and sockets.
- Do not install solar modules and wiring with wet plugs and sockets.

- Exercise extreme caution when carrying out and work on the wiring.
- High contact voltage can occur in the inverter when it is isolated.
- Protect solar modules from overvoltage e.g. voltage peaks of battery charges, generators, etc.
- At installation, modules should be kept entirely away from light or covered with a dark opaque material. When working with modules without any cover, the safety regulations for live electrical equipment need to be followed.
- Do not wear metallic rings, watchbands, ear, nose or lip rings or other metallic devices while installing or troubleshooting photovoltaic systems in order to avoid electric shock.
- Use only insulated tools that are approved for working on electrical installations. Abide with the safety regulations for all other components used in the PV system, including wiring and cables, connectors, charging regulators, inverters, storage batteries and rechargeable batteries, etc.
- Use only equipment, connectors, wiring and support frames suitable for a solar electric system. **Always use the same type of module within a particular photovoltaic system.**
- Do not attempt to repair any part of the PV module.

2.4 Fire Safety



ZNSHINE SOLAR PV modules have passed all the required safety tests according to the IEC EN 61730 Directives with Application Class A and fire safety has been rated as Class C. The devices of on-roof systems can affect the fire safety of a building. Improper installations can result in a hazard in case of fire. In the case of on-roof applications, the modules must be mounted above a fire-resistant surface.

- Rooftop installations should be placed over fire resistant roofs only; fire class A is recommended.
- For rooftop installations only fire resistant components should be used.
- Do not use panels near equipment or in places where flammable gases may be generated.

3. Installation



ZNSHINE SOLAR PV modules should be installed in a location where they will receive the maximum amount of sunlight throughout the year. In the Northern Hemisphere modules should face south, while in the Southern Hemisphere modules should face north.

- ZNSHINE SOLAR PV modules connected in series should be installed at same orientation and tilt angle. Different orientations or angles may cause a loss of power output due to the change in sunlight exposure.
- Do not immerse the module in liquid (IP 65). The installation of the modules to sea water lakes and seas should be about 500 meters.
- The module should not be exposed to unusual chemical loads.
- Protect solar modules from overvoltage e.g. voltage peaks of battery charges, generators, etc.
- If the module is connected to a storage battery all precautions of the battery manufacture should be adhered.
- Do not carry out installation in high winds. Protects every worker of slipping and falling from the roof. Prevent possible fallings from objects. Secure the work area so that nobody on the roof and beneath the roof can be injured.

When designing the final layout of the modules in the photovoltaic system (on the ground or on a roof), we recommend the designer to keep suitable access space to allow easy maintenance and inspection works. ZNSHINE SOLAR PV modules must be installed and stored in the following conditions:

Operating environment temperature	from	-40°C	to	+85°C
Storage temperature	from	-40°C	to	+60°C
Humidity	below 85 RH%			

- When installing a module on a roof or building, ensure that it is securely fastened and prevented from falling because of wind, snow or other mechanical loads.
- Provide adequate ventilation under a module for cooling. ZNSHINE SOLAR recommends 10 cm minimum air space between module and mounting surface.
- Modules should not to be shaded at any time of trees, antennas, cables, houses etc. If a module is shaded or even partially shaded, it will fail to perform at ideal conditions and results in lower power output.

3.1 Mechanical Installation

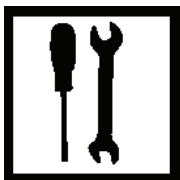

- Always use structures and materials specifically developed and certified for photovoltaic modules installation.
- The minimum distance between two fixed modules for linear thermal expansion of the module frames should be 5 mm. Nevertheless the recommended distance between two solar modules is 20 mm to allow wind circulation, in order to reduce pressure loads and improve module ventilation. The PV module should not be mounted in such a way that the drain holes of PV module can incur blockage.
- The PV modules are suitable for mechanical mounting both with a horizontal or vertical orientation. In choosing the orientation, please keep in mind the internal PV module by-pass diode configuration to ensure the optimum electrical behaviour from any potential shading over the modules.
- Galvanic corrosion can occur between the aluminium frame of the PV module and mounting hardware, if such hardware is composed of dissimilar metals, especially in harsh environments (such as environments with high humidity). In those cases, it is recommended to place neoprene tape, PVC washers or stainless steel washers between the PV module frame and the support structure to prevent corrosion.
- Additionally, all module support structures used to support PV modules at correct tilt angles should be wind and snow load rated by appropriate local and civil Directives prior to installation.



It is not allowed to dismount, drill or modify the frame or any other part of the PV module. Please contact ZNSHINE Technical Service Contact if module mounting procedure is not clear

PV modules by ZNSHINE SOLAR can be installed by means of the following processes:

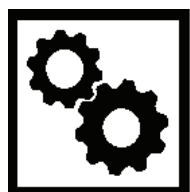

- Installations Using Frame Mounting Holes
- Installations Using Pressure Clamps
- Insertion Systems

3.1.1 Installations Using Frame Mounting Holes



Modules must be securely fixed to the mounting structure using the four pre-drilled mounting holes (14mm*9mm) placed in the long frame rails at 400 mm from the middle. Use M8 stainless steel hardware, spring washers and flat washers with a torque of approximately 10 newton metre [N m] for normal installation. Galvanized or hot dipped zinc plated hardware is also acceptable.

Please refer to the drawings on the Annex 1 to get more information about the proper use of mounting holes and load resistance of all module types. ZNSHINE SOLAR recommends to use all eight mounting holes, if excessive wind or snow loads are expected for the PV installation.

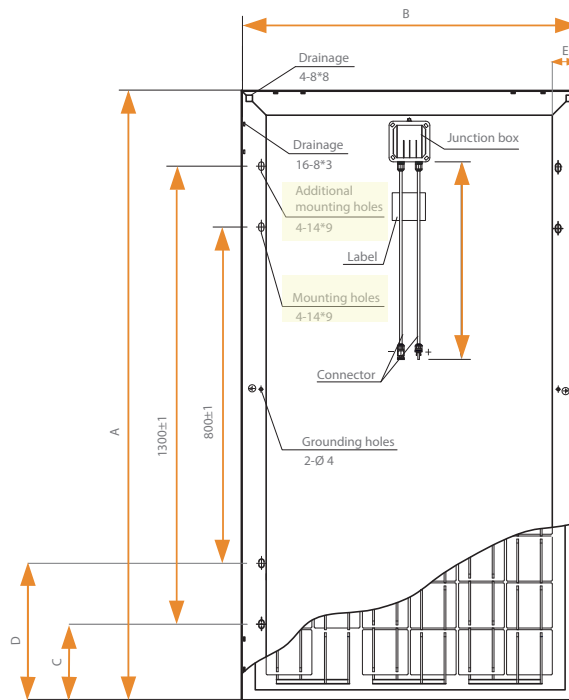

Picture 1 (top) : Mounting Holes; Picture 2 (bottom): Installation with Frame Mounting Holes

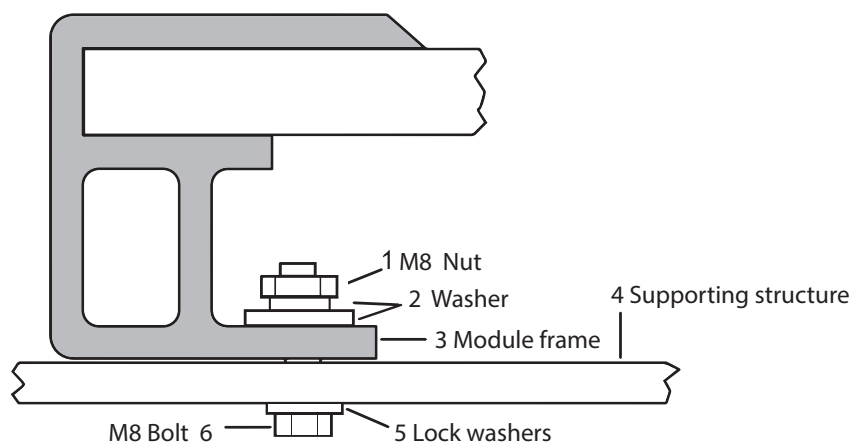

3.1.2 Installations Using Pressure Clamps



Installation using pressure clamps may be executed along both sides of the module frame according to instructions on **Annex 1**. The obligatory position of the clips along the frame depends on which side of the module is used for the installation as follows:

- **Fixing on the long side:** the clamps must be mounted along the frame at the position of the mounting hole. The clamps must be fixed at a distance 25% of the total side length from the frame edge with a tolerance of +/-50 mm.
- **Fixing on the short side:** The clamps must be mounted along the frame at the edges of the module, the clamp fixing area lies within 25% of the overall length of the short side from the frame edge.

Note that on both sides of the module the pressure clamps should be mounted always in a symmetric position with respect to the middle line for a proper load distribution. Refer to the drawings on the Annex 1.



- Clamps must be installed according to the manufacturer's specific instructions. Do not apply excessive pressure on the frame such that the frame deforms. ZNSHINE SOLAR recommends a torque of approximately 10 newton metre [N m], however, please refer to the clamp manufacturer for specific hardware and torque requirements.
- The clamps must only fix the modules through the contact with the frame only. Do not allow contact between clamp and glass and avoid shadowing effects from the module clamps.
- Pressure clamps should not be mounted outside the specified areas, otherwise the module mechanical resistance could be affected.

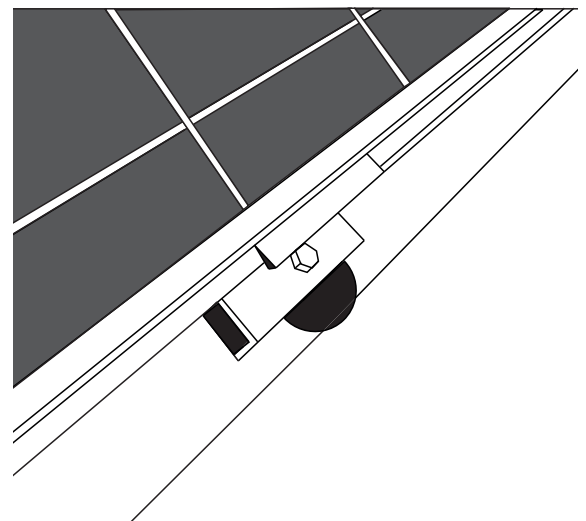
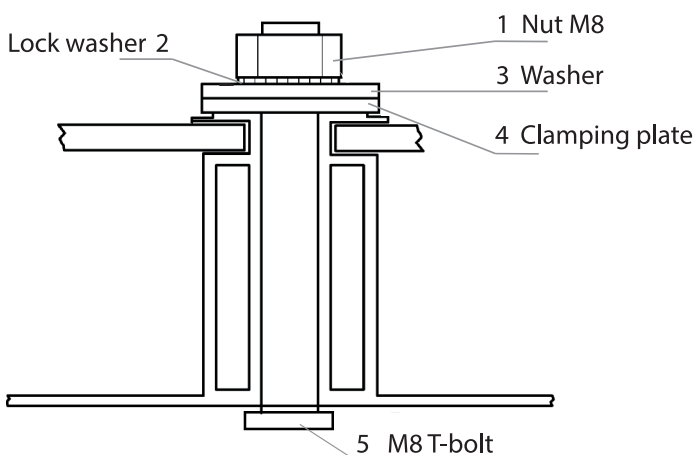

Picture 3: Installation with Pressure Clamps

3.1.3 Insertion Systems



Insertion systems on the short sides of the module are allowed with a limitation on the maximum load resistance of 2400 Pa. Insertion systems on the long side of the module are not affected by any limitation and are allowed with a maximum of 5400 Pa for snow load. See **Annex 1** for more information.

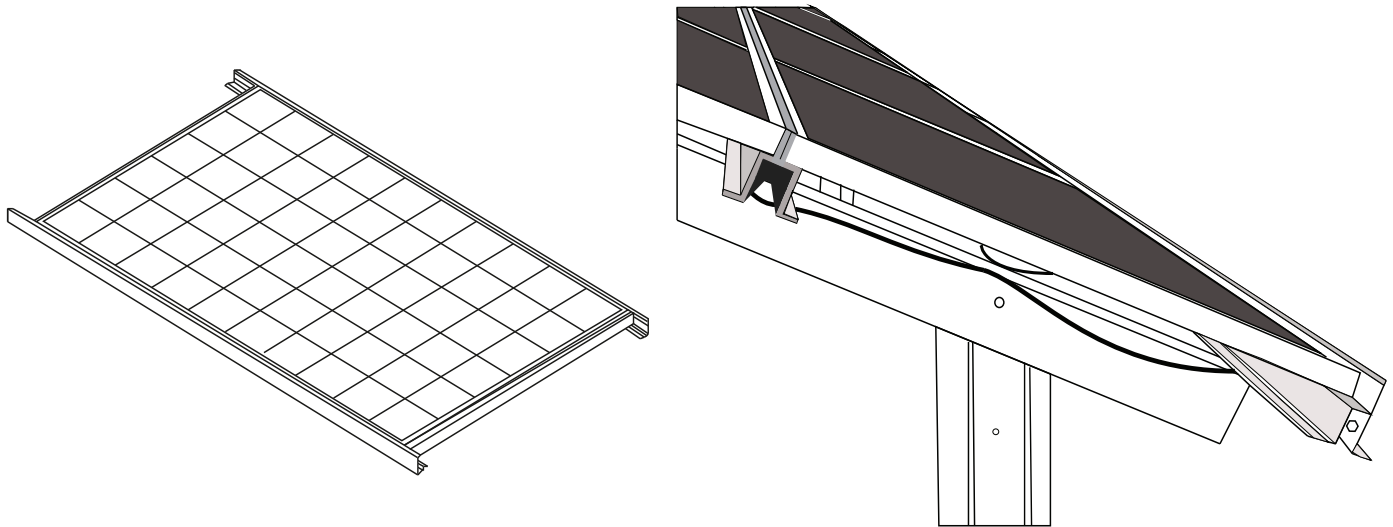

Picture 4: Insertion System

Note: When using insertion systems where the modules are installed sliding through the inner side of the rails, ZNSHINE SOLAR recommends to use PVC frame protectors in order to prevent damage in the anodized layer of the frame.

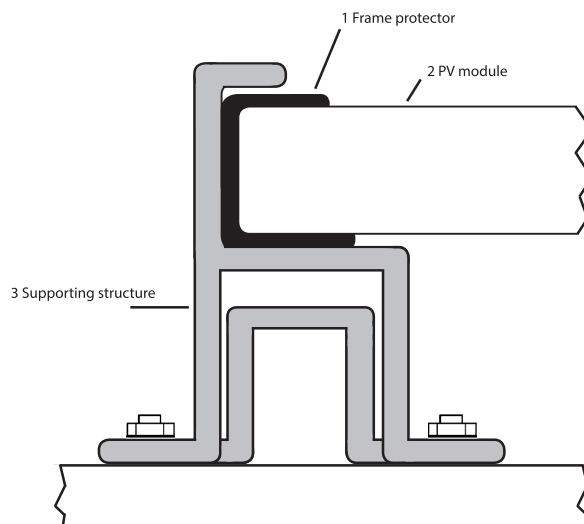

Picture 5: Insertion System

3.1.4 Module Load Resistance

Wind Load: 2400 Pa
 Snow Load: 5400 Pa

According to IEC 61215, clause 10.16, 2400 Pa corresponds to a wind pressure of 130 km/h (approximately +/- 800 Pa) with a safety factor of 3 for gusty winds. Please note that information provided above could vary according to the different mounting systems and configurations as described in the **Annex 1**.

3.2 Electrical Installation





The installation requires the execution of electrical connection works, for which knowledge of the relevant safety requirements is necessary. Having them carried out by unqualified personnel would be a risk.



Modules electrically connected together in a series/parallel configuration generate DC electrical energy which may be converted to AC by mean of a solar inverter. The resulting PV System may be therefore connected to the local utility grid system. As local utilities' policies and technical rules on connecting a renewable energy system to their power grids vary from region to region, consult a qualified system designers or integrators to design such a system to comply with the Directives. Permits are normally required for installing a PV system and the utility must formally approve and inspect the system before its connection to the grid can be accepted. The connection of the inverter to the grid needs to be done by a competent, authorized company.



- 
 The PV system electrical installation must be executed in accordance with the respective National Electrical Code or applicable National Regulations.
- 
 Use only insulated tools that are approved for working on electrical installations. Abide with the safety regulations for all the components used in the system, including wiring and cables, connectors, charge regulators, inverters, storage batteries etc.
- 
 To avoid conductor loops the strings (+and -) should be laid together. The cable groove on the cross profile can hereby be used. If possible roof penetration should only be at one point.

3.2.1 General Considerations



- Modules are fitted with two pre-assembled sunlight resistant, isolated cable leads, which are terminated with PV fast connectors. The positive (+) terminal has a female connector while the negative (-) terminal has a male connector. These cable leads and connectors must not be removed or cut off.
- Several modules are connected in series and then in parallel to form a PV array, especially for applications with high operating voltage. When modules are connected in series, the total voltage of the resulting string is the sum of the individual voltages of the modules. **Do not use different type of modules in the same circuit in order to avoid mismatch, power loss or damage to the PV system.**
- When selecting the size of the cables that connect the module strings to the solar inverter, it is recommended to refer to the nameplate electrical parameters of the related module type.
- When selecting the size of the cables that connect the module strings to the solar inverter, it is recommended to refer to the nameplate electrical parameters of the related module type.
- For electrical design considerations, the values given in the module label or data-sheet of the related model type should be multiplied by a factor of 1.25 for Short Circuit Current (I_{sc}) and 1.10 for Open Circuit Voltage (V_{oc}), when determining component voltage ratings, conductor current ratings, fuse sizes and the rest of electrical hardware connected to the module strings. Nevertheless, consult rated local wiring regulations to determine system wire size, type, and temperature allowed for your installation.
- Parallel interconnection of more than two strings requires the installation of string fuses. The maximum fuse current is stated to be 15 amps. If more than 2 strings are interconnected in parallel this value might be exceeded in the event of a fault.

3.2.2 System Grounding



ZNSHINE modules are certified for Class A applications (IEC 61730) Safety Class II, 1000Vdc Maximum System Voltage. Refer to respective National Electrical Code requirements and standards for safety-related grounding of racking system and/or module frames.

In case of executing the grounding of the module frames, ZNSHINE SOLAR recommends taking into account the following considerations:



- The long frame rails are equipped with pre-drilled grounding holes in their centre. These holes shall be used only for grounding purposes and must not be used for mounting purposes.
- Proper grounding is achieved by connecting the module frame(s) and structural members contiguously using a suitable grounding conductor. The grounding wire must be properly fastened to the module frame to assure good electrical contact. Use copper, copper alloy or any other conductive material accepted by the applicable National Electrical Regulation.
- Make electrical contact by penetrating the anodized coating of the aluminium frame. To break the anodized layer, ZNSHINE SOLAR suggests a stainless steel toothed washer to be inserted between the nut and the frame.
- When carrying out the grounding of the modules, the aluminium frame must not enter in permanent direct contact with dissimilar metals, which contact could result in a galvanic corrosion. Stainless steel flat washers can be inserted between frame and grounding lug.
- ZNSHINE SOLAR recommends the use of stainless steel grounding bolts or grounding lugs specifically designed for photovoltaic applications.

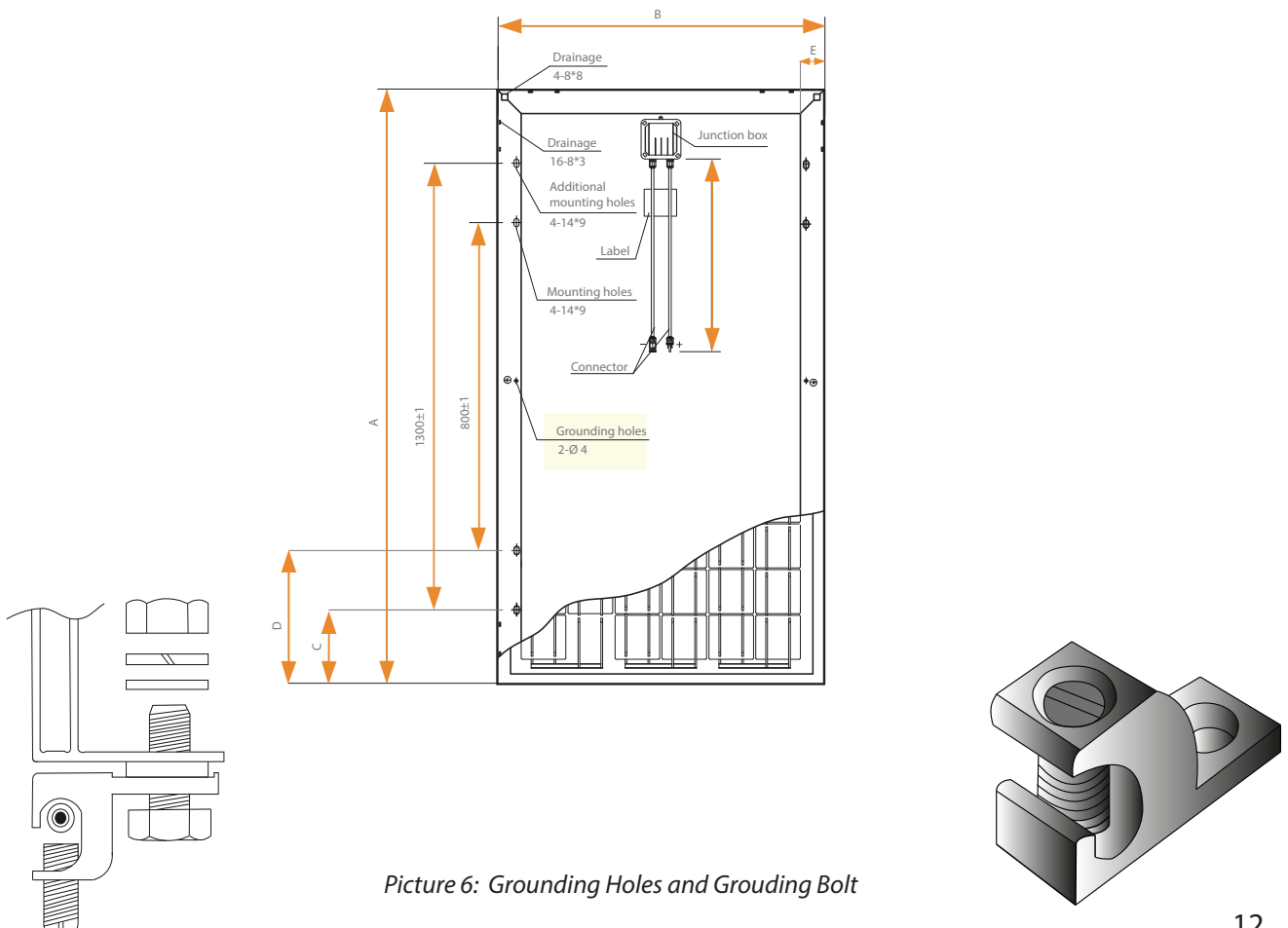

Picture 6: Grounding Holes and Grounding Bolt

4. Maintenance

4.1 General maintenance

ZNSHINE SOLAR recommends the following maintenance in order to ensure optimum performance of the module:

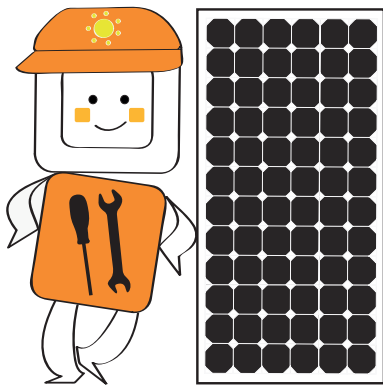

- Check the electrical and mechanical connections every six months to verify that they are clean, secure and undamaged;
- Check that mounting hardware, terminal screws and grounding components are tightly secured and are not affected by corrosion;
- Replacement modules must be the same type of those to be replaced;
- Modules generate high voltage when exposed to sunlight. Please cover the front surface of modules with an opaque no scratching material when repairing. Repairing works must be performed by specialized and properly trained personnel only;

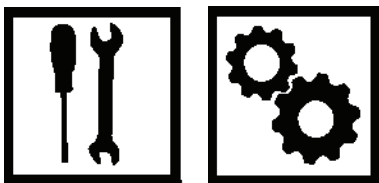

- Follow the maintenance instructions for all components used in the system, such as support frames, charge regulators, inverters, batteries etc.
- If any problem arises, have them investigated by a competent specialist.



- Do not touch live parts of cables and connectors;
- Use appropriate safety equipment (insulated tools, insulating gloves, etc.) when handling modules;
- Do not disconnect the grounding when doing system maintenance!
- For any electrical maintenance, the PV system must first be shut down. Improper maintenance can cause lethal electric shock and/or burns!

4.2 Cleaning



Dirt and dust can accumulate on the glass surface of the PV module over time, particularly in low inclination installations. This can cause a general decrease of power output and also sedimentation on the lower edge of the modules due to dirt accumulation. ZNSHINE SOLAR recommends a periodic cleaning of PV modules to ensure maximum power output, especially in regions with high quantity of dust in the air or low precipitations as follows:

- Under most weather conditions, normal rainfall is enough to keep the PV module glass surface clean. Clean the glass surface of the module as necessary and consider that lower inclination requires more cleaning frequency;
- Always use water and a soft sponge or cloth for cleaning. A mild, non-abrasive cleaning agent can be used to remove stubborn dirt. High mineral content water is not recommended, as it may leave residual deposits on the module;
- ZNSHINE SOLAR modules may be equipped with antireflective coating glass. This technology provides ZNSHINE SOLAR modules with high transmittance and low reflectivity features, which improves the module power output, reduces the dust and dirt deposition and produces very low glare. To avoid any damage to this layer do not clean the modules with high pressure washers, steam or corrosive chemicals. Do not use abrasive sponges or aggressive tools that could scratch the module surface; under no circumstance should the dirt be dry removed, as this would cause micro-scratches which could have a negative impact on the module's performances.
- To avoid a possible thermal shock clean the modules during early morning, when the module is still cold. This is especially recommended in regions with hotter temperatures;
- In cold environments with snow do not try to remove the frozen snow or ice from the module scratching on the front glass. Only soft snow can be removed gently with a soft brush in order to improve the production;
- Don't clean modules having broken glass or exposed wiring. This can cause a general electrical failure of the module or electrical shock hazard.



5. Modules' End of Life



ZNSHINE SOLAR is a member of the PV CYCLE Association, a European non-profit association managing a fully operational collection and recycling scheme for end-of-life photovoltaic modules throughout Europe. Please visit the website of PV CYCLE Association for further information: www.pvcycle.org

6. Module Specifications

Drawing for ZNSHINE SOLAR standard PV modules shown as below.

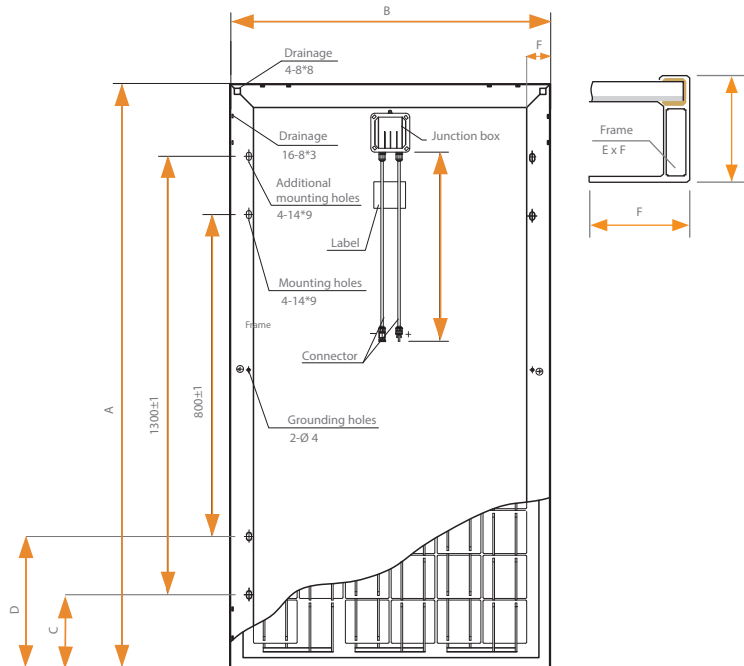

Picture 7: Module Drawing

	ZXM5-72	ZXM5-96	ZXM6-60 ZXP6-60	ZXM6-72 ZXP6-72
A	1580	1574	1640	1957
B	808	1081	992	992
C	140	137	170	247
D	390	387	420	618
E	35	45	40	50
F	35	35	30	35
Cable (mm)	900	900	900	1200
Weight (kg)	16	22	19,5	22,5
Cell Type	Mono 125	Mono 125	Mono/Poly 156	Mono/Poly 156
Nr. of Cells	72	96	60	72
Connector	MC4 compatible	MC4 compatible	MC4 compatible	MC4 compatible
Max Fuse Rating	10 A	10 A	15 A	15 A

7. Disclaimer of Liability

Installers must follow all safety precautions as described in this guide as well as local requirement and regulations by law or authorised organisations.

Because the use of this manual and the conditions or methods of installation, operation, use and maintenance of photovoltaic (PV) product are beyond ZNSHINE SOLAR's control, ZNSHINE SOLAR will not accept any responsibility and expressly disclaims any liability for loss, damage, or expense arising out of or in any way connected with such installation, operation, use or maintenance. No responsibility will be assumed by ZNSHINE SOLAR for any infringement of patents or other rights of third parties, which may result from use of the PV module. No license is granted by implication or otherwise under any patent or patent rights.

The information in this manual is based on ZNSHINE SOLAR's knowledge and experience and it is believed to be reliable. Nevertheless such information, including product specification (without limitations) and suggestions do not constitute a warranty, expresses or implied. ZNSHINE SOLAR reserves the right to change the manual, the PV modules, the specifications, or product information sheets without prior notice.

8. Contact Information

ZNSHINE Europe GmbH
Website : www.znshinesolar.com
Address: Am Hauptbahnhof 12
D-60329 Germany
Tel : (+49) 069 2566 89 90
Email : info@znshinesolar.de

ZNSHINE PV-Tech Co., Ltd
Website : www.znshinesolar.com
Address: #1, Zhixi Industrial Zone, Jintan,
213251 Changzhou, People's Republic of China
Tel. : +86 519 82449178
Email : service@znshinesolar.com

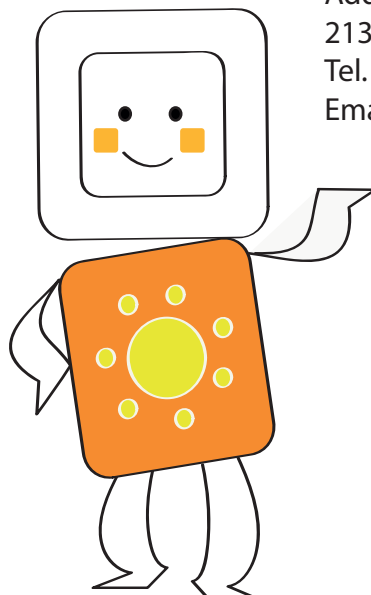

Annex 1

Installation Using Mounting Holes

Snow: 2400 Pa - Wind: 2400 Pa

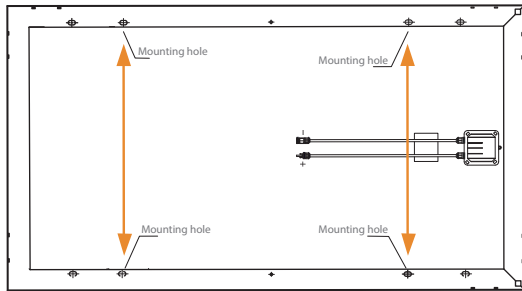

Snow: 5400 Pa - Wind: 2400 Pa

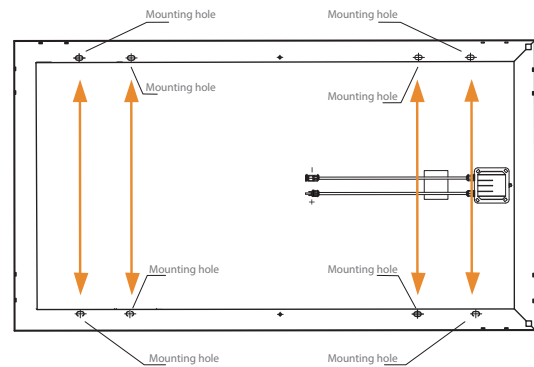

Installation Using Pressure Clamps

Clamping on the short side
Snow: 2400 Pa - Wind: 2400 Pa

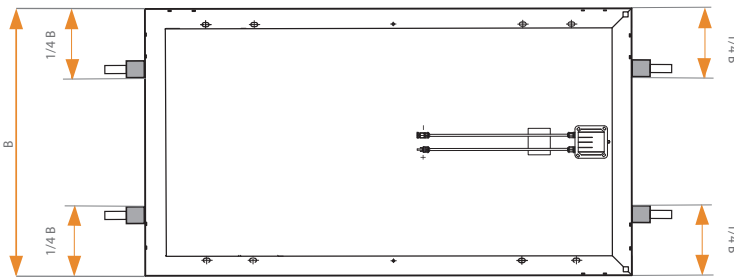

Clamping on the long side
Snow: 5400 Pa - Wind: 2400 Pa

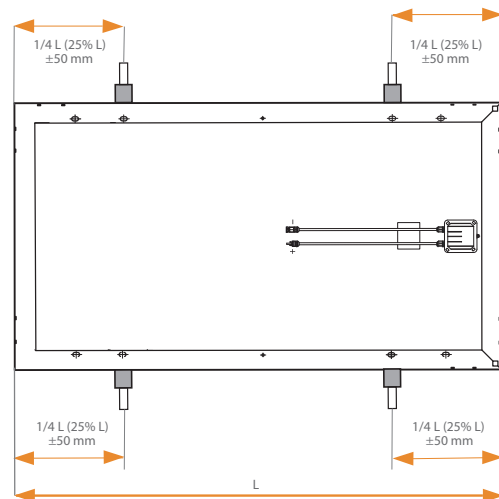

Insertion System

Snow: 2400 Pa - Wind: 2400 Pa

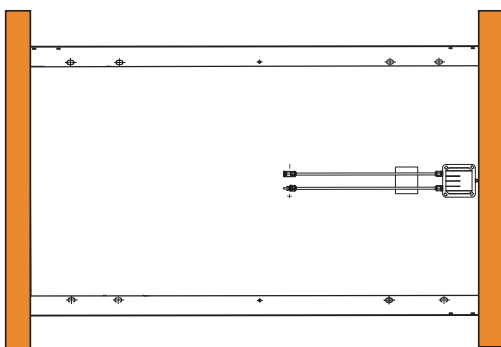

Snow: 5400 Pa - Wind: 2400 Pa

