

INSTALLATION MANUAL

REC PEAK ENERGY SERIES PHOTOVOLTAIC MODULES

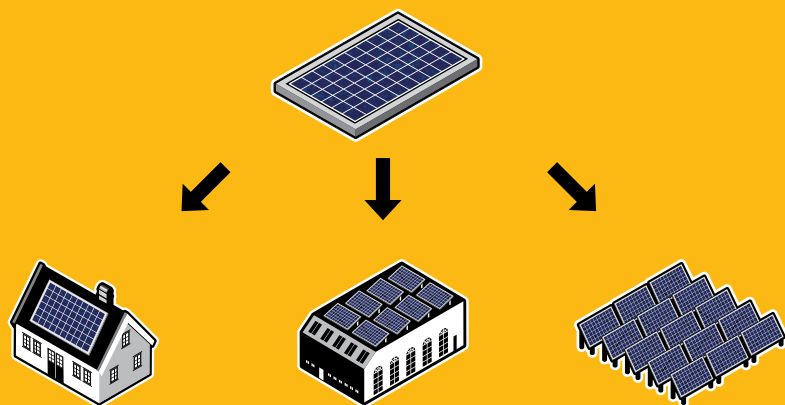

CONTENTS

- 3. Introduction
- 4. Electrical Installation
- 9. Mechanical Installation
- 15. Operating limitations
- 16. Maintenance
- 17. Legal Information

INTRODUCTION

Thank you for choosing REC photovoltaic modules. The REC Peak Energy series modules are ideal for solar systems designed to deliver long-lasting and reliable power output. These modules have been created through smart design and manufactured to the highest quality and environmental standards. With proper installation and maintenance, REC modules will provide you with clean renewable energy for several decades.

Please read this manual carefully. It contains critical information on safety, as well as detailed instructions for installing, operating and maintaining this module. Review the instructions and safety notes carefully before beginning any work on the system. Failure to do so can lead to personal injury or damage to property.

ELECTRICAL INSTALLATION



Caution: Only qualified personnel should perform work on PV systems, such as installation, commissioning, maintenance and repairs. Be sure to follow the safety instructions for all system components. It is also important to observe relevant local codes and regulations for health and safety and accident prevention.

A) ELECTRICAL REQUIREMENTS

Application Class:

Modules are rated for use in application class A (general access, hazardous voltage, hazardous power applications) according to IEC 61730.

System Requirements:

REC photovoltaic (PV) modules should only be used in systems where they meet the specific technical requirements of the system as a whole. Ensure that other system components will not cause mechanical or electrical damage to the modules.

Connection:

- If the modules are to be connected together in series, they should have the same amperage.
- If the modules are to be connected in parallel, they should have the same voltage.

String configuration:

If you use string configuration, plan and execute it according to the inverter manufacturer's instructions. The number of modules connected to an inverter should be within the inverter voltage limits and operating range. The design of the string configuration(s) should comply with the inverter's manufacturer's guidelines and must create a voltage less than the permitted total system voltage.

Wiring layout and configuration

In order to minimize voltage surges which could be induced by indirect lightning strikes, DC cables of the same string should be bundled together so that loops are kept as small as possible. String configurations should be checked before system commissioning. If the open circuit voltage (Voc) and the short circuit current (Isc) deviates from the specifications, this could indicate a configuration fault. Correct DC polarity should be observed at all times.

Connection of plug connectors

All connections should be secure, tight and electrically and mechanically sound.

Accessories and materials

UV-resistant cables and connectors approved for outside use should be used. Ensure that they are electrically and mechanically sound. Conductor gauge should be chosen so as to ensure that DC power losses (voltage drop) are kept to a minimum (less than 1% is preferred). National Electrical Code (NEC) and regulations need to be followed when selecting cables. For field connections, use minimum 4 mm² or #12 AWG copper wires insulated for a minimum of 90°C.

Protecting the cables

Cables should be secured to the array mounting system using UV-resistant cable ties, or other sunlight-

resistant device. Loose and unsecured cables should be protected from mechanical damage. Avoid, as far as possible, exposing the cables to direct sunlight and permanent tension.

Grounding (USA and Canada only)

You must ground all PV modules, using an electrical connection from the module frames to the ground. This must be done according to the following standards:

- Use a UL-listed grounding lug, such as the tin-plated versions of ILSCO GBL-4DB or CMC CL 50-DB lay-in lugs, or their equivalent.
- Attach the grounds to the existing grounding holes in the module frames.
- To ensure a conductive connection use a combination of screw, star washer and lock nut to mount the grounding lug onto the frame.
- Place the star washer between the frame and the nut, use Size #10 stainless steel screw, washer and locking nut to mount the lug to the module frame, and tighten with 5 ft-lbs (6.8 Nm) torque.
- The grounding wire size should be between 4 AWG and 14 AWG (21.2mm² - 2.1 mm²).
- Canada: The installation shall be in accordance with CSA C22.1, safety standard for electrical installations, Canadian electrical code, part 1.
- The torque for wire fastening should be in accordance with the following table:

GROUNDING DIMENSIONS AND TORQUE

Wire size [AWG]	Cross section [mm ²]	Type	Torque [in-lbs]	Torque [ft-lbs]	Torque [Nm]
4-6	21.2 - 13.3	Stranded	35	2.9	3.9
8	8.4	Stranded	30	2.5	3.4
10-14	5.3 - 2.1	Stranded/Solid	25	2.1	2.8

GROUNDING

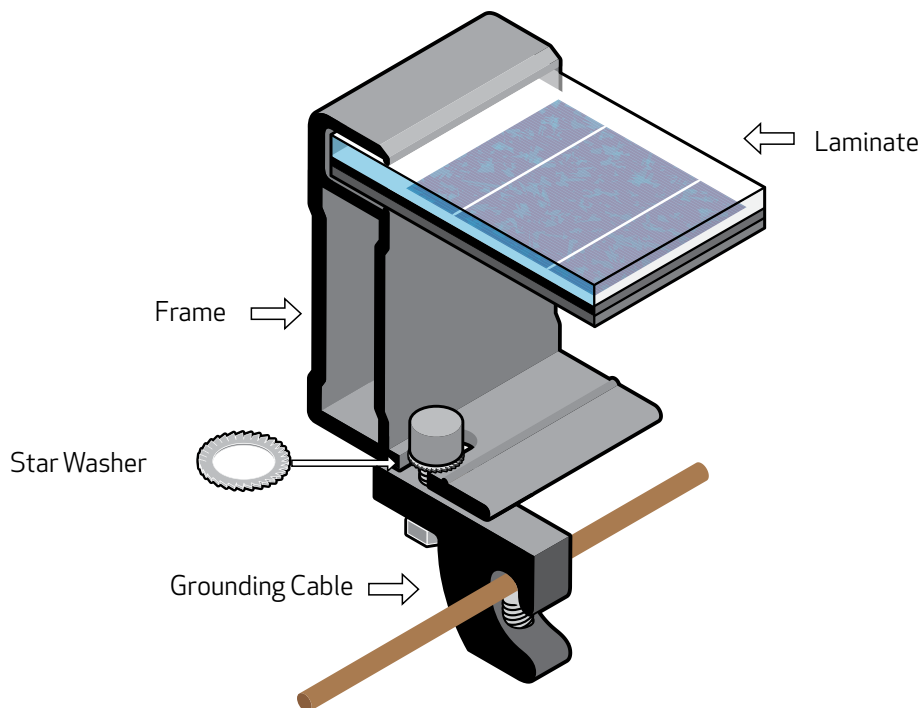

B) RATINGS

Values at Standard Test Conditions

See Electrical data table for STC Characteristics (Irradiance level 1000 W/m², Cell temperature 25°C, spectrum AM 1,5).

Values for I_{SC} , V_{OC} and P_{MPP} at STC are within tolerance of $\pm 10\%$.

ELECTRICAL DATA @ STC	REC225PE	REC230PE	REC235PE	REC240PE	REC245PE	REC250PE
Peak Power Watts P_{MAX} (Wp)	225	230	235	240	245	250
Power Output Tolerance - P_{MAX} (W)	0/+5	0/+5	0/+5	0/+5	0/+5	0/+5
Maximum Power Voltage - V_{MPP} (V)	29.1	29.4	29.8	29.9	30.2	30.5
Maximum Power Current - I_{MPP} (A)	7.7	7.8	7.9	8.0	8.1	8.2
Open Circuit Voltage - V_{OC} (V)	36.8	37.1	37.4	37.0	37.2	37.5
Short Circuit Current - I_{SC} (A)	8.2	8.3	8.3	8.6	8.7	8.8
Module Efficiency (%)	13.6	13.9	14.2	14.5	14.8	15.1

Values at Standard Test Conditions STC (Air Mass AM 1.5, Irradiance 1000 W/m², cell temperature 25°C).

At low irradiation of 200W/m² (AM 1.5 and cell temperature 25°C) at least 97% of the STC module efficiency will be achieved.

MAXIMUM RATINGS (IEC 61730 / IEC 61215)

Operational Temperature	-40 ... +80°C
Maximum System Voltage	1000V
Maximum Load	551 kg/m ² (5400 Pa)
Wind Speed	197 km/h (safety factor 3)
Max Series Fuse Rating	15A - DC
Max Reverse Current	15A - DC

Maximum ratings IEC

MAXIMUM RATINGS (UL 1703)

Operational Temperature	-40 ... +80°C
Maximum System Voltage	600V
Design Load	75.2 lbs/ft ² (3600 Pa)
Max Series Fuse Rating	15A - DC
Max Reverse Current	15A - DC

Maximum ratings UL

**Values at NOCT (Nominal Operating Cell Temperature):
Underwriters Laboratories Information (U.S. and Canada only)**

PEAK POWER	215WP	220WP	225WP	230WP	235WP
P_{MPP} (Wp)	156.9	159.6	162.3	165.4	168.3
I_{MPP} (A)	6.55	6.62	6.68	6.75	6.81

Values at NOCT (Irradiance level 800W/m², spectrum AM 1.5, wind velocity 1m/s, Tamb 20°C)
NOCT (Nominal Operating Cell Temperature): 47.9 ±2°C (235W Rated Module)

Under normal conditions, a photovoltaic module is likely to experience conditions that produce more current and/or voltage than reported at Standard Test Conditions. Accordingly, the values of I_{sc} and V_{oc} marked on this module should be multiplied by a factor of 1.25 when determining component voltage ratings, conductor ampacities, fuse sizes, and size of controls connected to the PV output.

Refer to section 690.8 of the US National Electric Code (NEC) for an additional multiplying factor of 125% (80% derating) which may be applicable.

The multiplying factor for the open circuit voltage of the module (V_{oc}) is according to Table 690.7 of the NEC code.

C) ELECTRICAL SAFETY

All relevant electrical installation codes and regulations should be referred to and observed. A copy of these instructions should be included in the system documentation.

Preventing the system from generating current

Solar modules automatically generate current (electricity) when exposed to light. To prevent this, shield the system with a non-transparent cover during installation, maintenance or repair work.

Unique Hazards of DC Electricity

Solar modules generate direct current (DC) electricity. Once the current is flowing, breaking or opening a connection (e.g. disconnecting a DC cable from the inverter) can cause a DC electrical arc. Unlike arcs occurring in conventional low voltage AC wiring, DC arcs are not self-extinguishing. They are a potentially lethal burn and fire hazard, capable of creating high temperatures that can destroy contacts and connectors.

Always:

- Follow the module and inverter manufacturer's installation, handling and operating instructions
- Remove/open the inverter AC fuse/circuit breaker before you disconnect the inverter from the public grid
- Switch off or disconnect the inverter and wait for the time specified by the manufacturer before working on it - its high-voltage components need sufficient time to discharge.

Safety Requirements:

The voltage produced by individual modules and modules connected in series (voltages are added together) or in parallel (currents are added together), can give rise to dangerous voltage and current.

Although the fully insulated plug contacts on the module's output cables provide touch-safe protection, you must observe the following points when handling the modules, in order to avoid the risk of sparking, fire hazard, burn risk, and lethal electric shocks.

- Exercise extreme caution when wiring the modules and look out for damaged cable ends, split cable ends, dirt, etc.
- Never insert metallic or otherwise conductive objects into the plugs or sockets.
- Ensure that all electrical connections are completely dry before they are assembled.
- Keep all materials, tools and working conditions clean and dry.
- Always use appropriate safety equipment such as insulated tools and insulated gloves.

MECHANICAL INSTALLATION



Caution: Only qualified personnel should perform work on PV systems, such as installation, commissioning, maintenance and repairs. Be sure to follow the safety instructions for all system components. It is also important to observe relevant local codes and regulations for health and safety and accident prevention.

A) FIRE GUIDELINES

Utilize the following fire safety guidelines when installing REC PE series modules:

- REC PE Series modules have a Class C Fire Rating.
- Check with local authorities for guidelines and requirements concerning fire safety for any building or structure that the modules will be mounted on or attached to.
- The system design should ensure that fire fighting personnel can access the system in the event of a building fire. Check with local authorities for any applicable regulations concerning setbacks or other placement restrictions that may apply for roof-mounted PV arrays.
- We recommend that you use DC Ground Fault Interrupters. This may also be required by local and national codes.
- All electrical appliances are subject to fire risk. The module should therefore be mounted over a fire retardant roof covering rated for the application and the minimum distance to the roof top should be 4 inches (10 cm).

B) ORIENTATION

To maximize system output, install the modules at optimum orientation and tilt angles. The specifics of this depend on the location and must be calculated by a qualified system designer.

The ideal angle for mounting the module should result in the sun's rays falling perpendicular (i.e. at a 90° angle) to the module surface. In each series string, all the modules should have the same orientation and tilt. This will ensure that they do not under-perform, as a result of mismatching of each module's outputs.

The modules should not be exposed to artificially concentrated light.

Even minor or partial shading of the modules/array will reduce array/system output. A module is considered shade-free when it is both:

- Free from shade or shadows all year round.
- Exposed to several hours of direct sunlight, even during shortest days of the year.

C) ENVIRONMENTAL FACTORS

The modules are designed to be installed in moderate/temperate climatic conditions.

The modules are not suitable for installation in potentially hazardous locations.

The modules should not be installed at the following locations:

- Near sources of flammable gases and vapors, such as gas/petrol stations, gas storage containers, spray paint facilities.
- Near open flames.
- Underwater or in a fountain or other similar water feature.
- Where they are exposed to salt. Recommended distance from the sea: 1600 feet (500 m)
- Where they are exposed to sulfur, such as near sulfur springs or volcanoes, because of the danger of corrosion.
- Where they can be exposed to corrosive chemicals.

D) MODULE HANDLING

Modules should be handled with care, and the warnings and instructions on their packaging should be observed. Follow these guidelines when unpacking, transporting or storing the modules:

- Record the module serial numbers before installation and note the information in the system documentation.
- Carry the modules using both hands and avoid using the junction box as a grip.
- Do not allow the modules to sag or bow under their own weight when being carried.
- Do not subject the modules to loads or stresses - and avoid stepping on or dropping them.
- Keep all electrical contacts clean and dry.
- If you need to store modules temporarily, keep them in a dry, properly ventilated room.
- Do not apply any forces to the backsheet.

Note that if the module front glass is broken or laminate back sheet damaged, it can expose personnel to hazardous voltages. Therefore:

- If you must mark modules, avoid using sharp or pointed objects.
- Never apply paints, adhesives, or detergents to the back of the laminate.
- Do not use any solar module that is damaged or has been tampered with.
- Never attempt to disassemble the modules.

E) MOUNTING

REC PE Series modules are designed strictly for capturing solar radiation and are not suitable for installation as overhead or vertical glazing.

The distance between the modules and the installation surface must be at least 10 cm to ensure adequate cooling.

The array mounting structure should be able to withstand anticipated wind and snow loads. At the bottom of the module frames there are openings which allow rain water to flow away.

NOTE: Do not cover the corner draining holes shown in the draining holes illustration

DRAINING HOLES

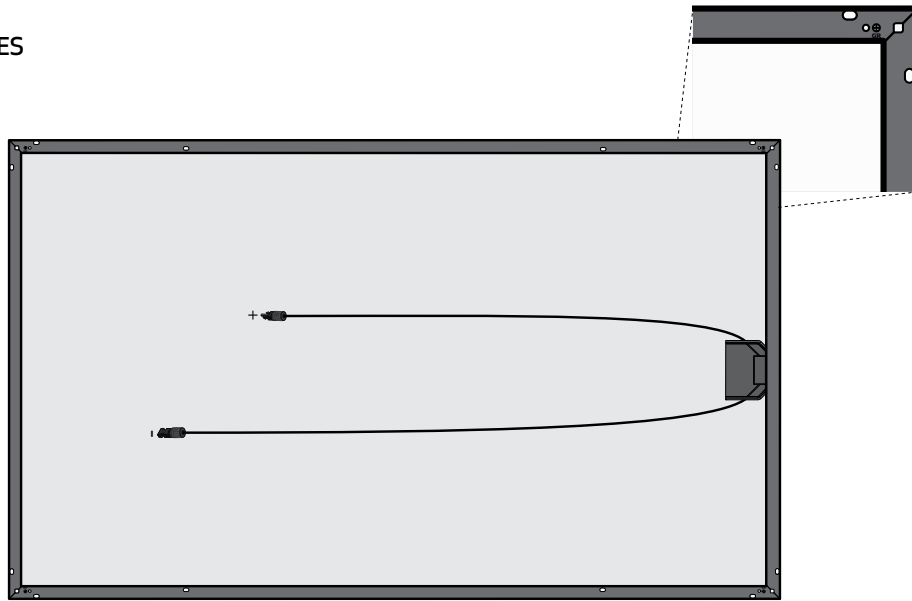

The maximum load the module should be subjected to must not exceed the module design load of 75.2 lb/ft² (3600 Pa) (UL1703) respectively maximum module load of 551 kg/m² (5400 Pa) (IEC61215). Site-specific loads such as wind and snow need to be taken into consideration to ensure that this weight loading is not exceeded.

The modules are built to withstand a downward force no greater than 551 Kg/m² (5400 Pa) with long-side mounting, no greater than 245 Kg/m² (2400 Pa) with short-side mounting (fig 4). Site-specific loads such as wind or snow need to be taken into consideration to ensure that this limit is not exceeded.

NOTE: In areas of snow build-up modules can be subjected to forces in excess of the stated limit even when snow depth does not appear extreme, thus causing damage to the framework. If the installation is likely to be affected by this, further suitable module support is recommended on the lower row of modules.

ARRAY

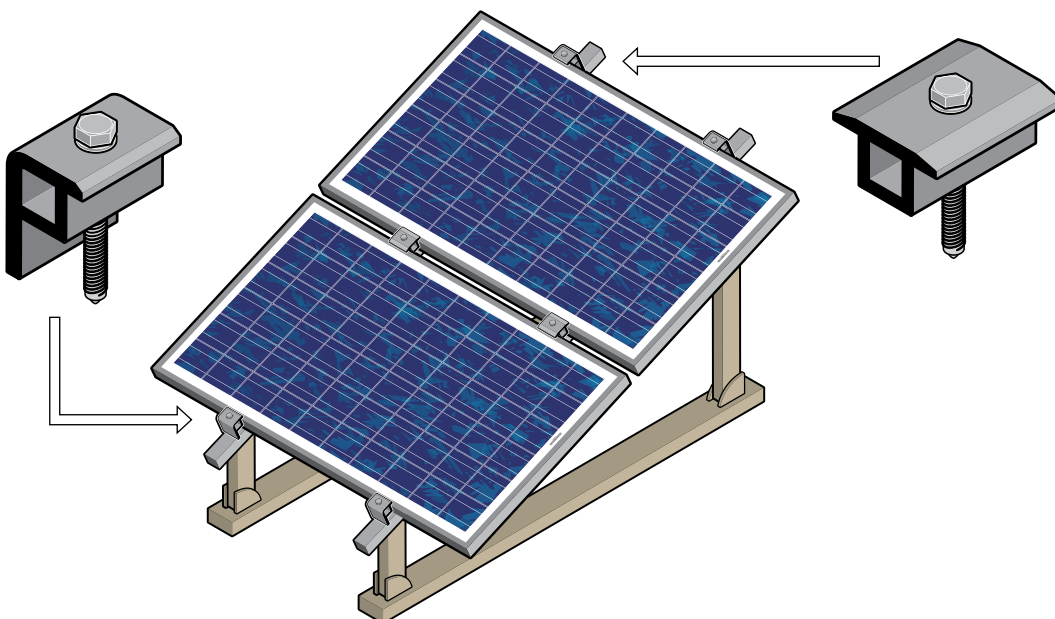

Fastening the modules to the mounting structure

Each module must be securely fixed to the mounting structure at a minimum of four points.

Clamps and rails

CLAMP SPECIFICATIONS

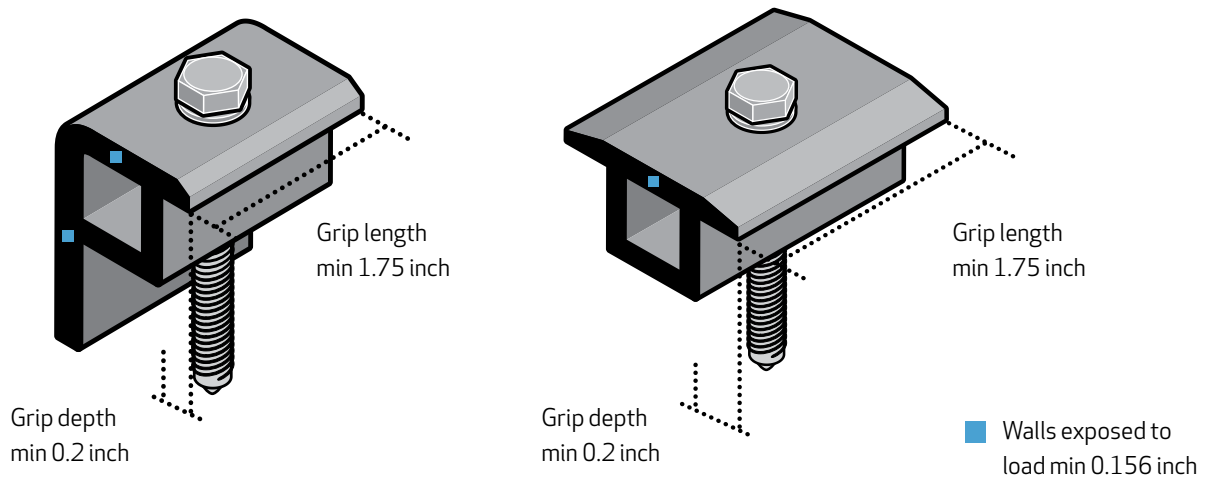

Use clamps of extruded aluminum with minimum yield strength of 2089 ton / ft² (200 MPa) and minimum tensile strength of 2610 ton / ft² (250 MPa), i.e. 6005 T5 alloy, with a minimum grip length of 1.75 inches (44.5 mm), minimum grip depth of 0.2 inches (5 mm) and a minimum thickness of load carrying walls of 0.16 inches (4 mm). Use size 5/16" stainless steel bolted connections with 5/16" split washer. The applied torque to fasten the clamps must be within the range of 9 ft lbs (12 Nm).

Approved types of clamps are the ones manufactured by SolaRak, Module End Clamp (part number 232-02018 or 232-02019) and Module Mid Clamp (part number 232-02015 or 232-02016). Follow the mounting equipment manufacturer's instructions and recommendations at all times.

The clamps should be fastened to C or H channel rails.

RAIL SPECIFICATIONS

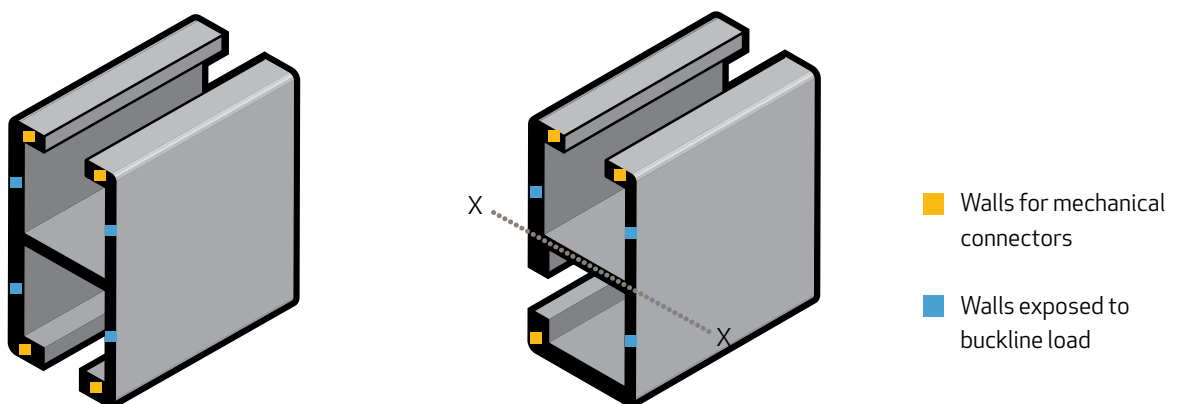

Thickness of walls for mechanical connections: min. 0.156 inch (4.0mm)
 Thickness of walls exposed to buckling load: min. 0.08 inch (2.0mm)
 Moment of Inertia for profile area about X-X: min. 0.4 inch⁴ (19.2cm⁴)

There are three ways of mounting the modules to the mounting structure.

Option 1; Long side mounting using clamps

The clamps should be fastened between 8.2 and 16.4 inches (208 – 416 mm) from the corner of the module. See drawing below, Long side mounting. The distance between the end clamp and the end of the rail should be minimum 1 in (25 mm).

LONG SIDE MOUNTING

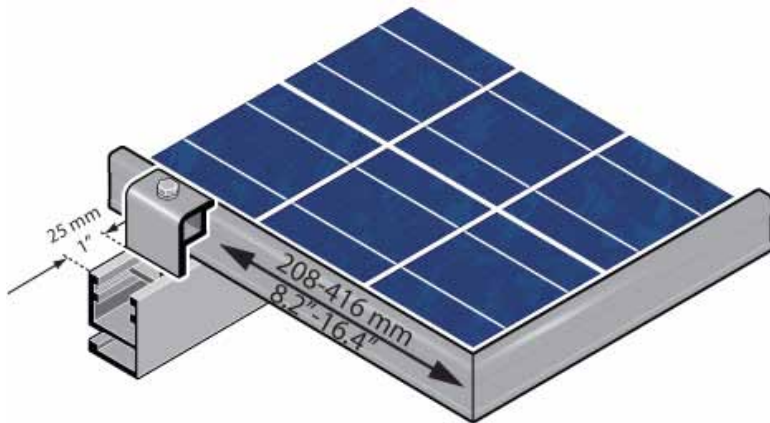

Option 2; Short side mounting using clamps

The modules can be fixed on the short side given the following constraints:

- Modules must be fixed in a way that the lower short side of frame is supported by the mounting structure (to reduce risk of damages due to sliding snow load).
- Draining holes in frame to be completely open (not in any way covered of mounting structure).
- The clamps must be mounted in a distance between 4.9 and 9.8 inches (125 – 250 mm) from the corner (as shown in the figure below).
- The distance between the end clamp and the end of the rail should be minimum 1 in (25 mm).
- The mechanical load must not exceed 2400 Pa at short side mounting.
- The minimum overlap between support rail and frame must be at least 6 mm.

SHORT SIDE MOUNTING

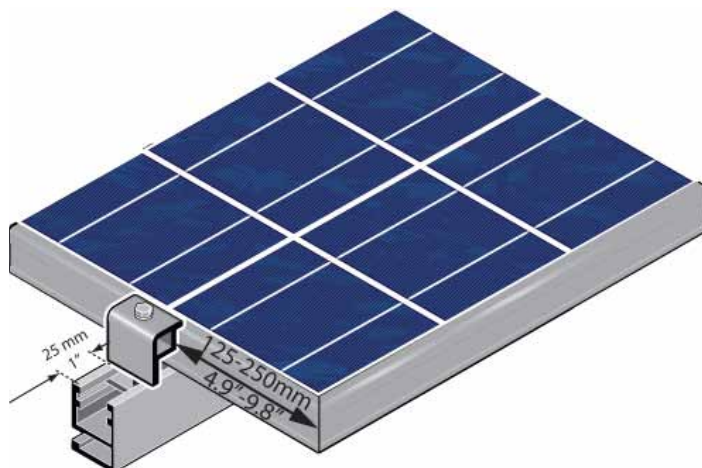

Option 3; Mounting holes

When mounting using the mounting holes, the module should be supported by two rails transversely at the mounting holes. The module should be mounted using lock nut and washer or lock nut with flange.

Additional electrical bonding to Earth Ground is required for the metal support structure (see earlier description of grounding). A torque wrench should be used to tighten nuts and bolts to specification. The applied torque required when using 1/4" bolts, as shown in the drawing below, Mounting using mounting holes, must be within a range of 9 ft lbs (12 Nm). All four existing mounting holes in the frame should be used. The under construction should be of aluminium or galvanized steel to avoid galvanic corrosion. The under construction should be appropriate for the local environment.

NOTE: The warranty will be voided if additional holes are made in the frame. All fixing and fastening materials should be corrosion resistant.

MOUNTING USING MOUNTING HOLES

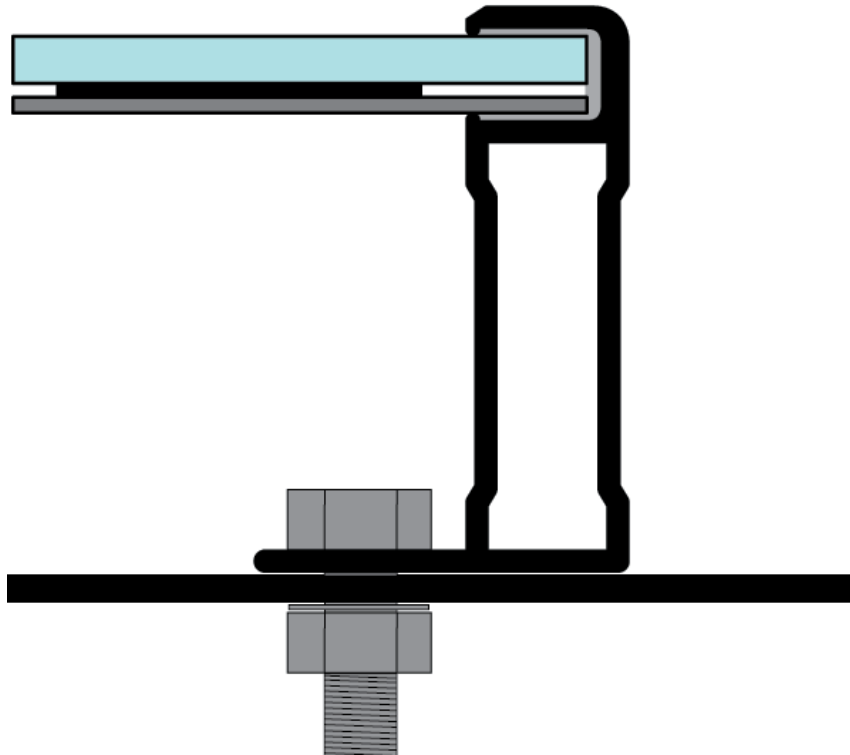

Preventing galvanic corrosion

To avoid galvanic corrosion, use of stainless steel fastening materials are the preferred choice, but galvanized or hot dipped zinc plated fasteners are acceptable.

OPERATING LIMITATIONS

REC PE Series modules are designed to be able to provide decades of durable and stable output in moderate/temperate climatic conditions. Operating temperatures should be between -40 and +80°C.

TEMPERATURE RATINGS (235 WRATED MODULE)	
Nominal Operating Cell Temperature (NOCT)	47.9°C (±2°C)
Temperature Coefficient of P _{MPP}	-0.46%/°C
Temperature Coefficient of Voc	-0.32%/°C
Temperature Coefficient of I _{sc}	0.011%/°C

MAINTENANCE

REC PE Series modules have been designed for easy maintainance. Normal rainfall will naturally clean the modules, if the modules is installed in a position with a sufficient tilt. The need for cleaning will vary with the location of the installation, amount of rainfall and pollution. To optimize the electrical output, it is recommended to clean the modules when dirt can be seen on the glass surface.

If dirt remains on the module surfaces, it will cause cell shading, which can reduce system power output. If necessary, cleaning can be done as a normal glass with non alkali window cleaner or cleaned with denatured spirits and finished cleaning with rinse with water. Cleaning liquid/agents which are acidic solutions (low pH value < 5) can therefore also be used in diluted form to remove as example calcium (except hydrofluoric acid!). Always finish cleaning with rinse with plenty of water.

For removal of moss or fungi and bacteria on the glass surface, the use of cleaning agent with active component benzalkoniumchlorid could be used. Rodalon® sold through the company Brenntag is recommended.

Please do not use any of the following:

- Alcalic (pH value > 9) cleaning liquid/agents
- Hydrofluoric acid (HF)
- Harsh cleaning materials such as scouring powder, steel wool and cloth with course metal treads in the weave, scrapers or other sharp instruments.

The system should be inspected regularly to ensure that:

- Fasteners are secure, tight and free of corrosion.
- Electrical connections are secure, tight, clean, and free of corrosion.
- The mechanical integrity of the cables is intact.
- Bonding points to Earth Ground are tight, secure, and free of corrosion (which could break the continuity between the modules and ground).

LEGAL INFORMATION

A) LIABILITY DISCLAIMER

REC Solar AS accepts no liability for the usability and functionality of its solar modules if the instructions in this guide are not followed. Since compliance with this guide and the conditions and methods of installation, operation, use and maintenance of the modules are not checked or monitored by REC Solar AS, REC Solar AS accepts no liability for damage arising from improper use or incorrect installation, operation, use or maintenance. This does not apply to damages due to a module fault, in cases of loss of life, bodily injury or damage to health or in the event of a grossly negligent breach of obligations on the part of REC Solar AS and/or in the event of an intentional or grossly negligent breach of obligations by a legal representative or vicarious agent.

B) DECLARATION OF CONFORMITY



EC Declaration of Conformity

We,

REC Modules Pte Ltd.
20 Tuas South Avenue 14
Singapore 637312
Singapore

hereby declare that the following product line

Peak Energy (PE) - Series

including the REC215PE, REC215PE (BLK), REC220PE, REC220PE(BLK), REC225PE, REC225PE(BLK), REC230PE, REC230PE(BLK), REC235PE, and REC235PE(BLK) models.

are in conformity with the provisions of the following EC directive:

LDV 2006/95/EC Low Voltage Directive

The following references of standards and technical specifications have been applied for in this EC/ EEA declaration of conformity.

IEC 61215, 2nd edition PV Modules - Design qualification and type approval
IEC 61730 Photovoltaic (PV) module safety qualification

The product was first marked with the CE mark in 2010

Oslo, January 31st, 2010

A handwritten signature in blue ink that reads 'Erik Løkke-Øwre'.

Erik Løkke-Øwre
Sr. Vice President Operations

MODULE SPECIFICATIONS

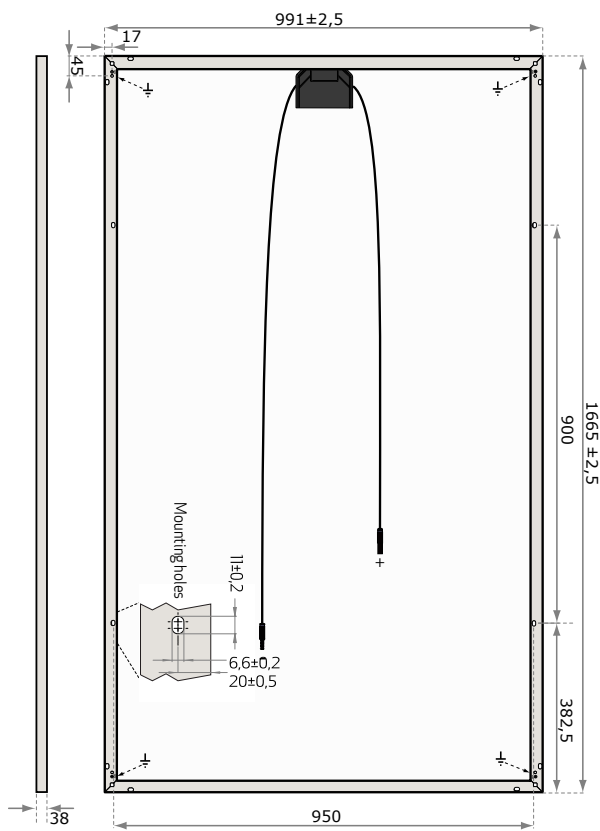

(measurements in mm)

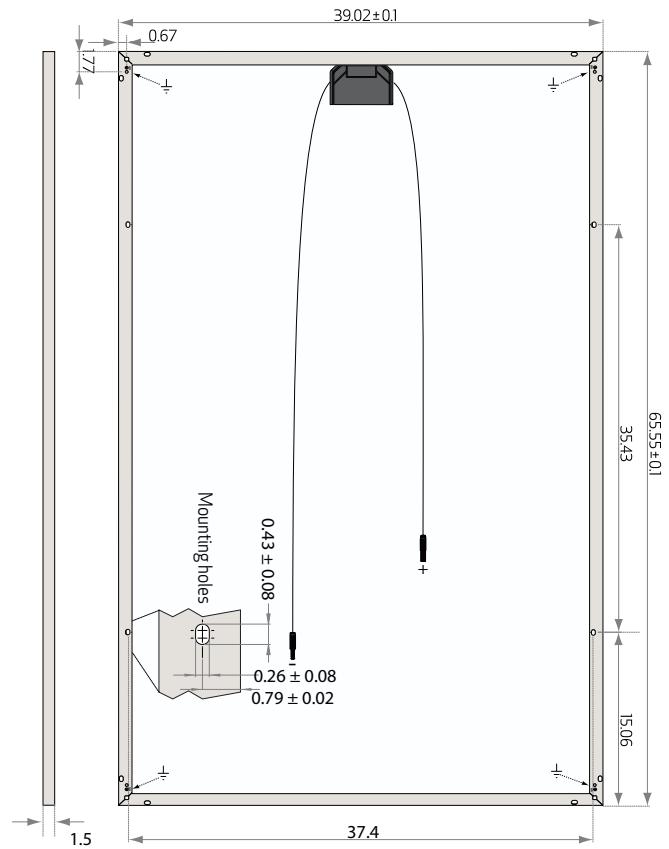

(measurements in inches)

MECHANICAL DATA

Dimensions	1665 x 991 x 38 mm (65.55 x 39.02 x 1.5 in)
Area	1.65 m ² (17.76 ft ²)
Weight	18 kg (40 lbs)
Temperature Coefficient of I _{sc}	0.074 %/°C

GENERAL DATA

Cell Type	6.14 x 6.14 in multi-crystalline cells, 60 in series
Glass	High-transparency solar glass with antireflection surface treatment by Sunarc Technology
Laminate	Double layer high performance polyester
Frame	Anodized aluminum



Renewable Energy Corporation ASA
Kjørboveien 29
PO Box 594
NO-1302 Sandvika
Norway
Tel: +47 67 57 44 50
Fax: +47 67 57 44 99

www.recgroup.com