



CS-882 OEM

ALARM UPGRADE FOR FACTORY KEYLESS ENTRY INSTALLATION & OPERATING INSTRUCTIONS

INTRODUCTION

CONGRATULATIONS on your choice of an Alarm Upgrade System by Crimestopper Security Products Inc. This booklet contains the information necessary for installing, using, and maintaining this system. If any questions arise, contact your installation dealer or Crimestopper Security Products Inc. at the Tech Support number below.

***IMPORTANT INFORMATION:**

This system does not improve or affect the range of the factory remote keyless entry transmitters. This is an **ADD-ON** system only. The arm/disarm range of this system will be identical to that of the Factory Keyless System's lock/unlock range.

TECH SUPPORT

Mon-Fri 8:00 AM-4:30 PM Pacific Time
(800) 998-6880

REV. A 8/2002 SW: PG30500030CT1

INSTALLATION PRECAUTIONS & WARNINGS

BEFORE BEGINNING, check all vehicle manufacturer cautions and warnings regarding electrical service (AIR BAGS, ABS BRAKES, BATTERY, ETC.).

DO NOT ROUTE ANY WIRING THAT MAY BECOME ENTANGLED with brake, and gas pedals, steering column, or any other moving parts in the vehicle.

COMPONENT MOUNTING

Control Unit: DO NOT mount or wiring harness where they can become entangled with moving parts such as brake/gas/clutch pedals, or the steering column! The control module should be mounted in a concealed location. Do not mount the control unit in the engine compartment.

LED: Mount in a visible location on the dashboard or console.

Valet/Program Button: Mount button in a hidden but accessible location. It is **REQUIRED** for emergency disarm, programming, and valet mode.

WIRING

VIOLET WIRE #1 & #2: ON-BOARD RELAY (10A) IMMOBILIZER CIRCUIT #1 NORMALLY OPEN

These wires are for an on board Relay to immobilize the Coil or Fuel Pump Circuit in the vehicle. Cut the selected circuit you want to immobilize and connect each end to a VIOLET wire.

NOTE (1): This is a high-security, normally open connection. If the alarm system is unplugged or loses power, the circuit will still be immobilized!

NOTE (2): This circuit has a maximum load of 10A and should NOT be used to interrupt a high current wire such as an Ignition supply or Starter circuit from the ignition switch!

WHITE/RED: (-) NEGATIVE HORN/SIREN OUTPUT

Connect to wire that activates the factory horn. If you choose to use this output with a standard alarm (warble) siren, then it should be connected to the black (negative) wire of the siren. Connect the red wire of the siren to constant (+) 12 Volts. NOTE: This wire is preset for a factory vehicle horn. You must change the programming for siren use. See programmable option #15.

BLACK WIRE: SYSTEM CHASSIS GROUND

THIS WIRE MUST BE CONNECTED TO CHASSIS METAL OF THE VEHICLE. Scrape away any paint or dirt from the area to ensure a good connection.

RED WIRE: +12V POWER INPUT (15 amp fuse)

Connect to +12 Volt source with supplied fuse & holder. Connect to the vehicle's battery Positive terminal.

WHITE WIRE: +12V FLASHING PARKING LIGHT OUTPUT X2 (15 amp fuse)

Connect to switched parking light wire at back of light switch. If this is not possible, connect directly to one of the parking lights at the front of the vehicle. Many European vehicles require separate right and left circuits. Use this second white wire to connect to the 2nd light circuit on your European vehicle. Otherwise do not use both white wires.

WIRING

ORANGE WIRE: (-) NEGATIVE STARTER DISABLE (Armed output)

Ground output when system is armed. This output is used for disabling the starter or to activate other optional devices such as scanner LED's, window control modules, voice modules etc. For starter kill, cut starter wire and connect between 87A and 30 on a relay. Connect orange wire to 85 and connect 86 to an Ignition source that has voltage in "ON" and "CRANKING" positions at the Ignition switch. (Starter disable relay not included)

PINK/WHITE WIRE: ON-BOARD RELAY (10A) IMMOBILIZER CIRCUIT #2 NORMALLY OPEN

PINK WIRE: ON-BOARD RELAY (10A) IMMOBILIZER CIRCUIT #2 NORMALLY OPEN

These wires are for an on board relay to immobilize the Coil or Fuel Pump Circuit in the vehicle. Cut the selected circuit you want to immobilize and connect one end to the Pink wire and the other end to the Pink/White wire.

NOTE (1): This is a high-security, normally open connection. If the alarm system is unplugged or loses power, the circuit will still be immobilized!

NOTE (2): This circuit has a maximum load of 10A and should NOT be used to interrupt a high current wire such as an Ignition supply or Starter circuit from the ignition switch!

YELLOW WIRE: +12 VOLTS IGNITION SWITCHED

Connect to an Ignition wire that shows +12 Volts with the key in both "On" and "Start" positions.

BLACK/WHITE WIRE: +12 VOLTS POWER TRUNK RELEASE INHIBIT INPUT (If Equipped)

Connect this wire to the positive side of trunk release solenoid. This input wire will allow the CS-882OEM system to sense when the Trunk Release Button is pressed on the Factory Remote Control. This will prevent an unwanted false alarm if your vehicle has a powered trunk/hatch release. At the instant a positive pulse is sensed on this wire, the trunk trigger, shock sensor, and current sensing features are bypassed. If the trunk is then re-closed (sensed by trunk pin) the zone will re-arm in 3 seconds, otherwise system is STILL ARMED EVEN THOUGH THE TRUNK IS OPEN and must be disarmed with the Unlock Button before entering vehicle.

BLUE WIRE: (-) or (+) DOOR TRIGGER (PROGRAMMABLE, DEFAULT IS NEGATIVE)

Connect to door pin activation circuit in vehicle:

- *Negative type door circuits show Ground when any door is opened and 12 volts when all doors are closed. Some vehicles may have isolated door triggers. In this case you may need to run additional wires from other doors or go directly to the wire at the vehicle's dome light.*
- *Positive type door circuits show 12 Volts when a door is opened such as on many Ford/Mercury vehicles.*

***TIP:** Many recent vehicles have door pin switches incorporated in the door latch itself, therefore there are not any "plunger" type door switches located in the door jamb. If your vehicle has no door pins, an alternative connection may be at courtesy light or locating the door triggers at a control module elsewhere in the vehicle. Call Tech Support for assistance.

WIRING

GREEN WIRE: (-) HOOD/TRUNK TRIGGER

Connect this wire to a grounding hood / trunk pin switch or to existing factory hood and trunk pin switches that read ground when open. If no existing switches are available, new pin switches may be installed. Note: DO NOT mount new pin switches in water pathways.

RED/WHITE: (+/-) Door Unlock Validation Signal INPUT: [Default Setting is Negative]

Connect to Vehicle's Door Unlock Switch wire. NOTE: The module must be programmed for the correct signal polarity. (Flipping switch on top of control module will change the input polarity.) This wire prevents system from being defeated simply by pressing the vehicle's unlock button at the door panel when triggered.

GREEN/WHITE: (+/-) Door Lock Validation Signal INPUT: [Default setting is Negative]

Connect to Vehicle's Door Lock Switch wire. NOTE: The module must be programmed for the correct signal polarity. (Flipping switch on top of control module will change the input polarity.) Prevents system from being armed when manually pressing the vehicle's Lock button at the door panel.

BLUE/BLACK: Door Unlock Signal INPUT:

Connect to Vehicle's (+12V) Door Unlock (Solenoid/Motor) Wire.

YELLOW/BLACK: Door Lock Signal INPUT:

Connect to Vehicle's (+12V) Door Lock (Solenoid/Motor) Wire.

****SEE DOOR LOCK MOTOR / VALIDATION WIRE CONNECTIONS NEXT PAGE**

WIRING: MINI PLUGS

2-PIN PLUG (WHITE): PROGRAM/VALET BUTTON Connects to white plug on module.

2-PIN PLUG (RED): LED INDICATOR (RED FLASHING LIGHT) Connects to red plug on module.

3 PIN SENSOR PLUG:

WHITE Wire: Negative Signal

BLACK Wire: Sensor Ground

RED Wire Sensor +12V Power

SHOCK SENSOR: The sensor supplied with this system does not require any additional wiring. Simply mount the sensor in a suitable location, plug it in, and adjust the sensitivity.

CURRENT SENSING

The CS-882OEM system includes a current sensing circuit to monitor current flow through the vehicles electrical system. If an intruder opens a door and the interior lights turn on, the CS-882 system will detect a current drain and trigger the alarm without having to connect (hardwire) this system to the interior dome light circuit and hood/trunk pin switches. If your vehicle includes courtesy lights in the trunk and/or under the hood, the system should also protect those areas when in current sensing. Current sensor is off by default. See diagram at right.

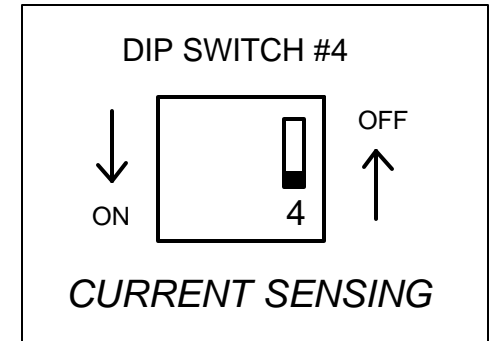

CURRENT SENSING NOTES:

- 1. Current sensing may be a problem for you if your vehicle has a thermostatically controlled fan system that may turn on after you have set the alarm and left the vehicle. The fan turning on will cause a false alarm trigger.**
- 2. Some vehicles with large or more than one battery will not operate well in current sensing mode because there is not enough voltage drop for the unit to detect a light turning on. If you experience problem with current sensing, please use the hard-wired door and hood/trunk inputs.**

RESISTORS & DIODES

*The enclosed diodes and resistors are only used for alternative installations that **DO NOT** +12V or Grounding validations signals. (Door Lock/Unlock Switch wires).*

Connect components as follows:

Yellow/Black: wire from CS882 connects to one side of resistor.

Remaining side of resistor connects to band end of diode.

Non-band end of diode (anode) connects to parking light switched +12 volt wire.

Blue/Black: wire from CS882 connects to one end of 2nd resistor.

Remaining side of resistor connects to band end of 2nd diode.

Non-band end of diode (anode) connects to door lock solenoid switch that switches from ground to +12 volts when locking and unlocking.

DOOR / LOCK & VALIDATION WIRES (TYPICAL INSTALLATION)

VALIDATION WIRES ON (MODE A = DIP SWITCHES 1-3 ON):

The Validation wires serve as a secondary input to prevent the system from being armed or disarmed simply by pushing the unlock button on the vehicle.

ARM/DISARM VALIDATION WIRES:

ARMING: The CS-882OEM system will NOT ARM if a NEGATIVE (or POSITIVE*) pulse is sensed on the GREEN/WHITE wire. (The Lock button on the door panel vehicle was pressed)

DISARMING: The CS-882OEM system will NOT DISARM if a NEGATIVE (or POSITIVE*) pulse is sensed on the RED/WHITE wire. (The Unlock button on the door panel was pressed).

*See Positive/Negative Signal setting diagrams at right and below.

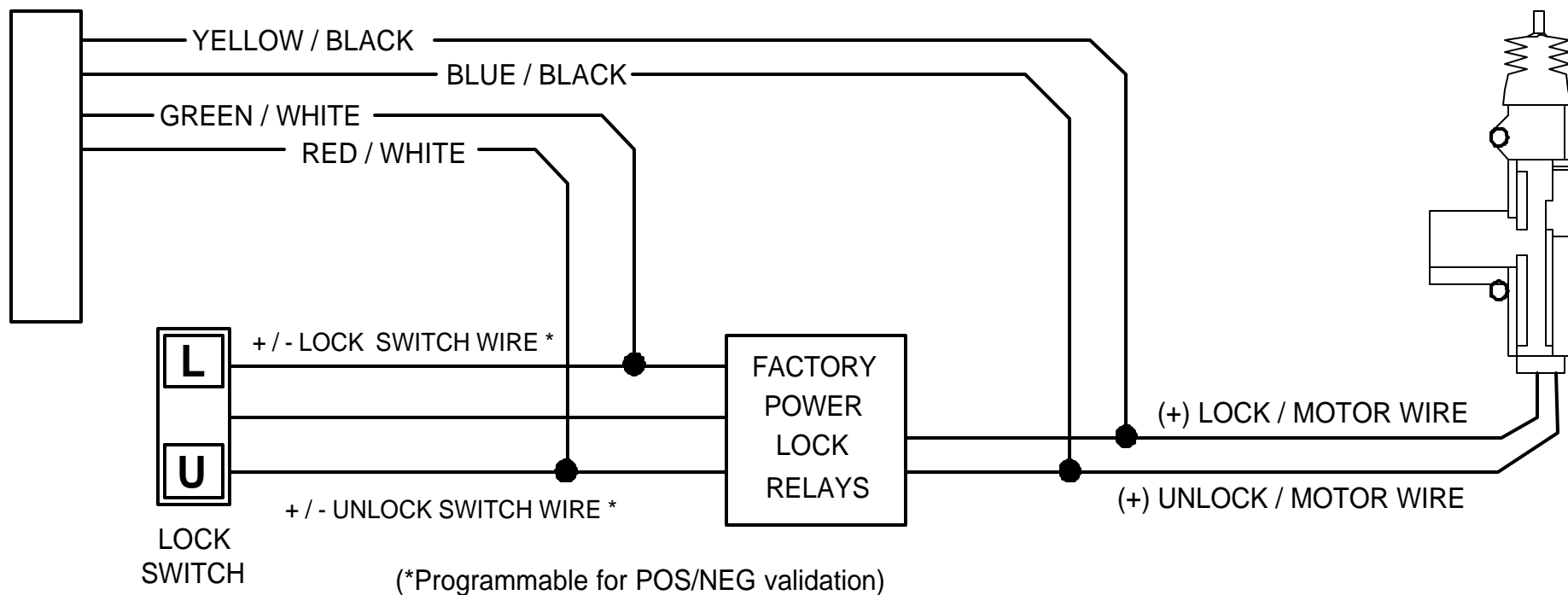
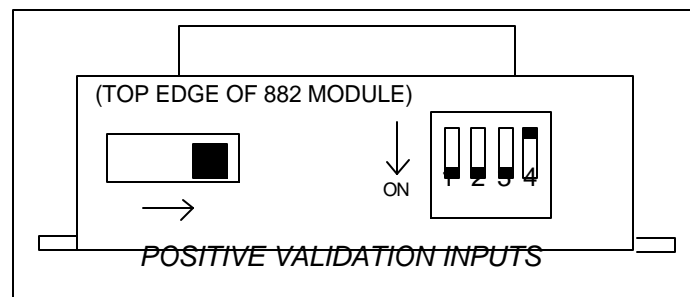
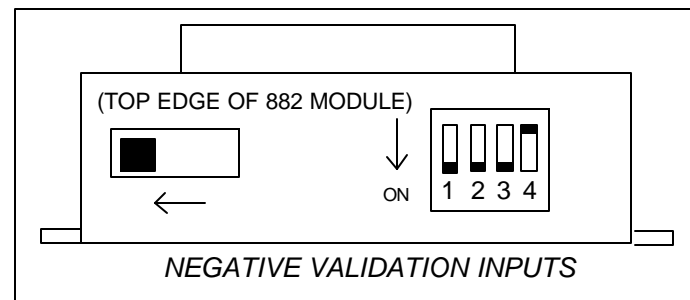

PROGRAMMABLE OPTIONS

1. Turn the Ignition ON and press the Override/Program button 7 times within 10 seconds.
2. Turn OFF Ignition. LED will flash slowly once per second as an indicator the system is in programming mode.
3. Within 20 seconds, press the Override/Program button the number of times that corresponds to the feature list below. The siren will chirp for each button press. **DO NOT LOSE COUNT!!** If you can hold down the button for 3 seconds and release you get 2 chirps. A 3-second button press is the same as pressing the button 10 times.
4. When you get to the desired option number, turn the Ignition from OFF to ON to toggle between the preset and alternate settings. The siren will chirp once or twice indicating which value the feature is at. See Below for Option numbers, descriptions, and values. Ignition should be left in the OFF position once you have the correct value.
5. At this time, if you need to change more options, repeat steps 3 & 4 above.
6. To exit programming Mode, Turn Ignition ON and press the Override/Program button once.

OPTIONS CHART

Option #	Option Description	PRE-SET Value (1 chirp)	ALTERNATE Value (2 chirps)
1	Flashing Lights	ON	OFF
6	Siren Chirps	ON	OFF
8	Passive Arming	OFF	ON
10	Door Trigger Input Polarity (Blue wire)	NEGATIVE	POSITIVE
14	Allow Panic Mode	OFF	ON
15	Horn or Siren output (White/Red wire)	HORN	SIREN
25	Restore all options to PRE SET VALUES	YES	

OPERATION

ARMING

To arm the alarm and lock the doors, press the Lock button of your Factory Keyless Remote Control. The 882 OEM system will sense the Door Lock signal and Arm. The lights will flash once, the vehicle horn or siren will chirp once. After 3 seconds, the LED indicator will begin flashing slowly and Immobilizer circuits become active. This system is now armed and ready to protect the vehicle.

ALARM TRIGGERING:

If there is an intrusion into the vehicle or hard impact to the body the alarm will sound which consists of flashing lights and siren or pulsing car horn for 30 seconds. After the 30 second alarm cycle duration the system will stop, but is still armed. LED will begin flashing rapidly indicating the alarm has been triggered.

DISARMING:

To disarm the CS-882 OEM, press the Unlock button of your Factory Keyless Remote. The CS-882 OEM system will sense the Door Unlock signal and Disarm. The lights will flash twice and the vehicle horn or siren will chirp twice. The LED will stop flashing. If the system was tripped in your absence, then the siren or horn will chirp 4 times and the lights will flash 4 times. If you hear 4 chirps/flashes, we recommend inspecting your vehicle for a theft attempt or damage.

PASSIVE ARMING MODE (Programmable Option)

When programmed for Passive (Automatic Last Door Arming) the CS-882 will arm itself 30 Seconds after the ignition is turned off and the last door has been closed. If a door is reopened, the system will wait for the door to close before arming.

DUAL-STAGE SHOCK PROTECTION

If a low-level shock to the vehicle body is detected, the pre-warning sensor activates sounding 1 siren/horn chirp and one light flash. If a hard impact to the vehicle occurs, the system will trigger for 30 seconds. Adjust the shock sensor as needed by turning the control knob clockwise to increase sensitivity and counter-clockwise to decrease sensitivity.

EMERGENCY OVERRIDE/DISARM

If the CS-882 system is armed and you have lost your Factory Keyless Remote or it stops working, you will have to perform an emergency override. Enter your vehicle manually with the key, (this will trip the alarm) turn the Ignition ON, and press override/program button 5 times within 8 seconds to disarm the system. The system will chirp/flash 4 times when disarmed.

OPERATION

VALET MODE

To disable alarm functions of the 882 system, turn the Ignition ON and press the override/program button 3 times within 8 seconds. After 8 seconds, the dash LED turns on solid as an indicator that the system is in valet mode. Repeat this steps to exit VALET mode. The LED will go out, system will chirp (2) times and the light will flash (2) times when exiting valet mode.

When in VALET mode the siren will still chirp for lock/unlock confirmation even though alarm functions are disabled. The CS-882 system will chirp 2 times when locking the doors and 3 times when unlocking the doors.

PANIC MODE (Programmable Option)

To activate your system during an emergency situation or to attract attention to your vehicle, press the Lock button on your remote 3 times within 5 seconds. This will activate a 30-second alarm trigger. Press any button on your remote to disarm.

FACTORY TRUNK RELEASE SENSING

If the CS-882 system is installed in a vehicle with trunk pop or hatch release button on the Factory Remote, there is a special input wire that will prevent the system from triggering if the trunk button on your remote is pressed while the system is armed.

WIRING DIAGRAM

