

SIMATIC NET

SPC3LV Siemens PROFIBUS Controller

Hardware Description

Date 2008/08

SIEMENS

SIMATIC - NET

SPC3LV

Hardware Description

(Siemens PROFIBUS Controller
according to IEC 61158)

Version: 1.0
Date: 2008/08

Liability Exclusion

We have tested the contents of this document regarding agreement with the hardware and software described. Nevertheless, there may be deviations, and we don't guarantee complete agreement. The data in the document is tested periodically, however. Required corrections are included in subsequent versions. We gratefully accept suggestions for improvement

Copyright

Copyright © Siemens AG 2003. All Rights Reserved.
Unless permission has been expressly granted, passing on this document or copying it, or using and sharing its content are not allowed. Offenders will be held liable. All rights reserved, in the event a patent is granted or a utility model or design is registered.

Subject to technical changes.

Versions

Release	Date	Changes
V 1.0	2008/08	Documentation about 3.3 Voltage SPC3

Directory

1	INTRODUCTION	6
2	FUNCTION OVERVIEW	7
3	PIN DESCRIPTION	8
4	MEMORY ALLOCATION	10
4.1	Memory Area Distribution in the SPC3	10
4.2	Processor Parameters (Latches/Register)	12
4.3	Organizational Parameters (RAM)	14
5	ASIC INTERFACE	15
5.1	Mode Register	15
5.1.1	Mode Register 0	15
5.1.2	Mode Register 1 (Mode-REG1, writable):	17
5.2	Status Register	18
5.3	Interrupt Controller	20
5.4	Watchdog Timer	23
5.4.1	Automatic Baud Rate Identification	23
5.4.2	Baud Rate Monitoring	23
5.4.3	Response Time Monitoring	23
6	PROFIBUS-DP INTERFACE	24
6.1	DP_Buffer Structure	24
6.2	Description of the DP Services	27
6.2.1	Set_Slave_Address (SAP55)	27
6.2.2	Set_Param (SAP61)	28
6.2.3	Check_Config (SAP62)	29
6.2.4	Slave_Diagnosis (SAP60)	30
6.2.5	Write_Read_Data / Data_Exchange (Default_SAP)	31
6.2.6	Global_Control (SAP58)	33
6.2.7	Read_Inputs (SAP56)	34
6.2.8	Read_Outputs (SAP57)	34
6.2.9	Get_Config (SAP59)	34
7	HARDWARE INTERFACE	35
7.1	Universal Processor Bus Interface	35
7.1.1	General Description	35
7.1.2	Bus Interface Unit (BIU)	35
7.1.3	Switching Diagram Principles	37
7.1.4	Application with the 80 C 32	39
7.1.5	Application with th 80 C 165	39

7.1.6	Interface Signals	41
7.2	UART	41
7.3	ASIC Test	41
8	TECHNICAL DATA	42
8.1	Maximum Limit Values	42
8.2	Permitted Operating Values	42
8.3	DC-Specifikation of the I/O- Drivers	42
8.4	AC-Specification for the Output Drivers	43
8.5	Timing Characteristics	44
8.5.1	SYS Bus Interface	44
8.5.2	Timing of the Synchronous C32-Mode:	45
8.5.3	Timing of the Asynchronous Intel Mode (X86 Mode) :	47
8.5.4	Timing in the Synchronous Motorola Mode (E_Clock-Mode, for example, 68HC11) :	48
8.5.5	Timing in the Asynchronous Motorola-Mode (for example, 68HC16) :	50
8.5.6	Serial Bus Interface	52
8.5.7	Housing	53
8.5.8	Processing Instructions	54
9	PROFIBUS INTERFACE	55
9.1	Pin Assignment	55
9.2	Example for the RS 485 Interface	56
10	APPENDIX	57
10.1	Addresses	57
10.2	General Definition of Terms	58
10.3	Ordering of ASICs	58
11	APPENDIX A: DIAGNOSTICS PROCESSING IN PROFIBUS DP	59
11.1	Introduction	59
11.2	Diagnostics Bits and Expanded Diagnostics	59
11.2.1	STAT_DIAG	59
11.2.2	EXT_DIAG	59
11.2.3	EXT_DIAG_OVERFLOW	61
11.3	Diagnostics Processing from the System View	61
12	APPENDIX B: USEFUL INFORMATION	62
12.1	Data format in the Siemens PLC SIMATIC	62

1 Introduction

For simple and fast digital exchange between programmable logic controllers, Siemens offers its users several ASICs. These ASICs are based on and are completely handled on the principles of the EN 50170 Vol. 2, of data traffic between individual programmable logic controller stations.

The following ASICs are available to support intelligent slave solutions, that is, implementations with a microprocessor.

The **ASPC2** already has integrated many parts of Layer 2, but the **ASPC2** also requires a processor's support. This ASIC supports baud rates up to 12 Mbaud. In its complexity, this ASIC is conceived primarily for master applications.

Due to the integration of the complete PROFIBUS-DP protocol, the **SPC3** decisively relieves the processor of an intelligent PROFIBUS slave. The **SPC3** can be operated on the bus with a baud rate of up to 12 MBaud. The SPC3LV is interoperable with the SPC3. It is a 3.3 Voltage SPC3.

However, there are also simple devices in the automation engineering area, such as switches and thermoelements, that do not require a microprocessor to record their states.

There are two additional ASICs available with the designations **SPM2** (Siemens Profibus Multiplexer, Version 2) and **LSPM2** (Lean Siemens PROFIBUS Multiplexer) for an economical adaptation of these devices. These blocks work as a DP slave in the bus system (according to DIN E 19245 T3) and work with baud rates up to 12 Mbaud. A master addresses these blocks by means of Layer 2 of the 7 layer model. After these blocks have received an error-free telegram, they independently generate the required response telegrams.

The LSPM2 has the same functions as the SPM2, but the LSPM2 has a decreased number of I/O ports and diagnostics ports.

2 Function Overview

The SPC3 makes it possible to have a price-optimized configuration of intelligent PROFIBUS-DP slave applications.

The processor interface supports the following processors:

Intel:	80C31, 80X86
Siemens:	80C166/165/167
Motorola:	HC11-,HC16-,HC916 types

In SPC3, the transfer technology is integrated (Layer 1), except for analog functions (RS485 drivers), the FDL transfer protocol (Fieldbus Data Link) for slave nodes (Layer 2a), a support of the interface utilities (Layer 2b), some Layer 2 FMA utilities, and the complete DP slave protocol (USIF: User Interface, which makes it possible for the user to have access to Layer 2). The remaining functions of Layer 2 (software utilities and management) must be handled via software.

The **integrated 1.5k Dual-Port-RAM** serves as an interface between the SPC3 and the software/application. The entire memory is subdivided into 192 segments, with 8 bytes each. Addressing from the user takes place directly and from the internal microsequencer (MS) by means of the so-called base pointer. The base-pointer can be positioned at any segment in the memory. Therefore, all buffers must always be located at the beginning of a segment.

If the SPC3 carries out a DP communication the SPC3 automatically sets up all DP-SAPs. The various telegram information is made available to the user in separate data buffers (for example, parameter setting data and configuration data). Three change buffers are provided for data communication, both for the output data and for the input data. A change buffer is always available for communication. Therefore, no resource problems can occur. For optimal diagnostics support, SPC3 has two diagnostics change buffers into which the user inputs the updated diagnostics data. One diagnostics buffer is always assigned to SPC3 in this process.

The **bus interface** is a parameterizable synchronous/asynchronous 8-bit interface for various Intel and Motorola microcontrollers/processors. The user can directly access the internal 1.5k RAM or the parameter latches via the 11-bit address bus.

After the processor has been switched on, procedural-specific parameters (station address, control bits, etc.) must be transferred to the **Parameter Register File** and to the **mode registers**.

The *MAC status* can be scanned at any time in the **status register**.

Various events (various indications, error events, etc.) are entered in the **interrupt controller**. These events can be individually enabled via a mask register. Acknowledgement takes place by means of the acknowledge register. The SPC3 has a common interrupt output.

The integrated **Watchdog Timer** is operated in three different states: 'Baud_Search', 'Baud_Control,' and 'DP_Control'.

The **Micro Sequencer (MS)** controls the entire process.

Procedure-specific parameters (buffer pointer, buffer lengths, station address, etc.) and the data buffer are contained in the integrated **1.5kByte RAM** that a controller operates as Dual-Port-RAM.

In **UART**, the parallel data flow is converted into the serial data flow, or vice-versa. The SPC3 is capable of automatically identifying the baud rates (9.6 kBd - 12 MBd).

The **Idle Timer** directly controls the bus times on the serial bus cable.

3 Pin Description

The SPC3LV has a 44-pin PQFP housing with the following signals:

Pin	Signal Name	In/Out	Description	Source / Destination
1	XCS	I	Chip-Select C32 Mode: place on VDD. C165 Mode: CS-Signal	CPU (80C165)
2	XWR/E_Clock	I	Write signal /EI_Clock for Motorola	CPU
3	DIVIDER	I	Setting the scaler factor for CLK2OUT2/4. low potential means divided through 4	
4	XRDR/R_W	I	Read signal / Read_Write for Motorola	CPU
5	CLK	I	Clock pulse input	System
6	VSS			
7	CLKOUT2/4	O	Clock pulse divided by 2 or 4	System, CPU
8	XINT/MOT	I	<log> 0 = Intel interface <log> 1 = Motorola interface	System
9	X/INT	O	Interrupt	CPU, Interrupt-Contr.
10	AB10	I(PD)	Address bus C32 mode: <log> 0 C165 mode: address bus	
11	DB0	I/O	Data bus C32 Mode: Data/address bus multiplexed C165 Mode: Data/address bus separated	CPU, memory
12	DB1	I/O		
13	XDATAEXCH	O	Data Exchange state for PROFIBUS-DP	LED
14	XREADY/XDTACK	O	Ready for external CPU	System, CPU
15	DB2	I/O	Data bus C32 mode: data bus/address bus multiplexed	CPU, memory
16	DB3	I/O	C165 mode: data/address bus separate	
17	VSS			
18	VDD			
19	DB4	I/O	Data bus C32 mode: data bus/address bus multiplexed	CPU, memory
20	DB5	I/O	C165 mode: data bus/address bus separate	
21	DB6	I/O		
22	DB7	I/O		
23	MODE	I	<log> 0 = 80C166 Data bus/address bus separated; ready signal <log> 1 = 80C32 data bus/address bus multiplexed, fixed timing	System
24	ALE/AS	I	Address latch enable C32 mode: ALE C165 mode: <log> 0	CPU (80C32)
25	AB9	I	Address bus C32 mode: <log> 0 C165 mode: address bus	CPU (C165), memory
26	TXD	O	Serial send port	RS 485 sender
27	RTS	O	Request to Send	RS 485 sender
28	VSS			
29	AB8	I	Address bus C32 Mode : <log> 0 C165 Mode: address bus	
30	RXD	I(5V)	Serial receive port	RS 485 receiver
31	AB7	I	Address bus	System, CPU
32	AB6	I	Address bus	System, CPU
33	XCTS	I	Clear to send <log> 0 = send enable	FSK modem
34	XTEST0	I	Pin must be placed fixed at VDD.	
35	XTEST1	I	Pin must be placed fixed at VDD.	
36	RESET	I(ST)	Connect reset input with CPU's port pin.	
37	AB4	I	Address bus	System, CPU
38	VSS			
39	VDD			
40	AB3	I	Address bus	System, CPU
41	AB2	I		
42	AB5	I		
43	AB1	I	Address bus	System, CPU
44	AB0	I		

Figure 3.1: SPC3 Pin Assignment

- Note:**
- All signals that begin with X.. are LOW active
 - VDD = +3.3V, VSS = GND

I (5V): Input 5V tolerant

I (PD): Input Pull-Down 50K

I (ST): Input Schmitt trigger

4 Memory Allocation

4.1 Memory Area Distribution in the SPC3

The figure displays the division of the SPC3 1.5k internal address area.

The internal latches/register are located in the first 21 addresses. The internal latches/register either come from the controller or influence the controller. Certain cells can be only read or written. The internal work cells to which the user has no access are located in RAM at the same addresses.

The organizational parameters are located in RAM beginning with address 16H. The entire buffer structure (for the DP-SAPS) is written based on these parameters. In addition, general parameter setting data (station address, Ident no., etc.) are transferred in these cells and the status displays are stored in these cells (global control command, etc.).

Corresponding to the parameter setting of the organizational parameters, the user-generated buffers are located beginning with address 40H. All buffers or lists must begin at segment addresses (48 bytes segmentation).

Address	Function
000H	Processor parameters Latches/register (22 bytes) internal work cells
016H	Organizational parameters (42 bytes)
040H	DP- buffer: Data In (3) * Data Out (3) * Diagnostics (2) Parameter setting data (1)
5FFH	Configuration data (2) Auxiliary buffer (2) SSA-buffer(1)

Figure 4.1: SPC3 Memory Area Distribution

Caution:

The HW prohibits overranging the address area. That is, if a user writes or reads past the memory end, 400H is subtracted from this address and the user therefore accesses a new address. This prohibits overwriting a process parameter. In this case, the SPC3 generates the RAM access violation interrupt. If the MS overranges the memory end due to a faulty buffer initialization, the same procedure is executed.

* Data In is the input data from PROFIBUS slave to master
Data out is the output data from PROFIBUS master to slave

The complete internal RAM of the SPC 3 is divided logically into 192 segments. Each segment consists of 8 bytes. For more informations about the contents of the 3 memory areas see previous chapter. The physical address is build by multiplikation with 8.

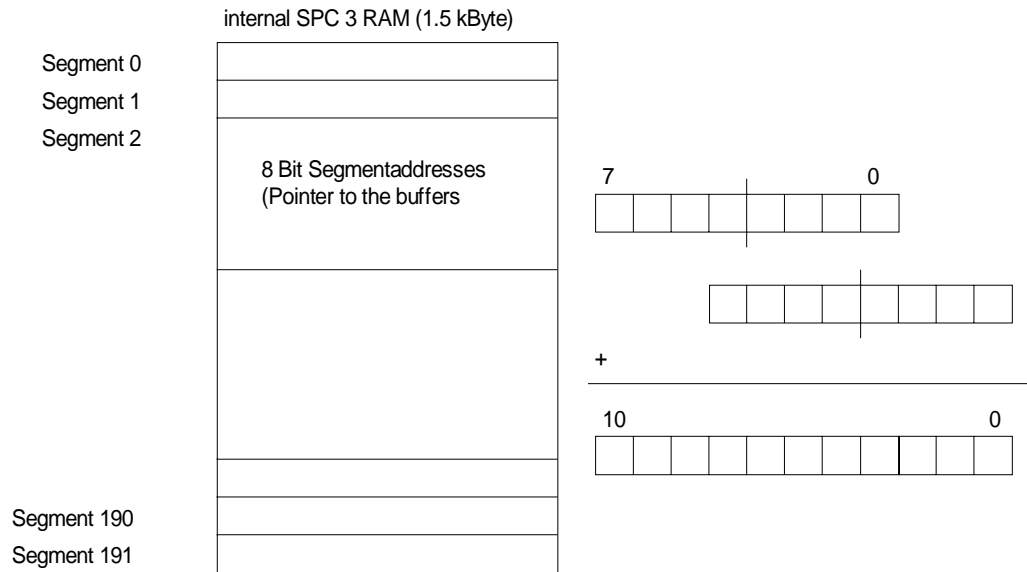

4.2 Processor Parameters (Latches/Register)

These cells can be either read only or written only. SPC3 carries out “address swapping” for an access to the address area 00H - 07H (word register) in the Motorola mode. That is, the SPC3 exchanges

address bit 0 (generated from an even address, one uneven, and vice-versa). The following sections more clearly explain the significance of the individual registers.

Address Intel / Motorola		Name	Bit No.	Significance (Read Access!)
00H	01H	Int-Req-Reg	7..0	Interrupt Controller Register
01H	00H	Int-Req-Reg	15..8	
02H	03H	Int—Reg	7..0	
03H	02H	Int—Reg	15..8	
04H	05H	Status-Reg	7..0	Status Register
05H	04H	Status-Reg	15..8	
06H	07H	Reserved		
07H	06H			
08H		DIN_Buffer_SM 7..0		Buffer assignment of the DP_Din_Buffer_State_Machine
09H		New_DIN_Buffer_Cmd	1..0	The user makes a new DP Din buffer available in the N state.
0AH		DOUT_Buffer_SM	7..0	Buffer assignment of the DP_Dout_Puffer_State_Machine
0BH		Next_DOUT_Buffer_Cmd	1..0	The user fetches the last DP Dout-Buffer from the N state.
0CH		DIAG_Buffer_SM	3..0	Buffer assignment for the DP_Diag_Puffer_State_Machine
0DH		New_DIAG_Puffer_Cmd	1..0	The user makes a new DP Diag Buffer available to the SPC3.
0EH		User_Prm_Data_OK	1..0	The user positively acknowledges the user parameter setting data of a Set_Param-Telegram.
0FH		UserPrmDataNOK	1..0	The user negatively acknowledges the user parameter setting data of a Set_Param-Telegram.
10H		User_Cfg_Data_OK	1..0	The user positively acknowledges the configuration data of a Check_Config-Telegram.
11H		User_Cfg_Data_NOK	1..0	The user negatively acknowledges the configuration data of a Check_Config-Telegram.
12H		Reserved		
13H				
14H		SSA_Bufferfreecmd		The user has fetched the data from the SSA buffer and enables the buffer again.
15H		Reserved		

Figure 4.2: Assignment of the Internal Parameter Latches for READ

Address Intel /Motorola		Name	Bit No.	Significance (Write Access !)
00H	01H	Int-Req-Reg	7..0	Interrupt- Controller - Register
01H	00H	Int-Req_Reg	15..8	
02H	03H	Int-Ack-Reg	7..0	
03H	02H	Int-Ack-Reg	15..8	
04H	05H	Int—Mask-Reg	7..0	
05H	04H	Int—Mask-Reg	15..8	
06H	07H	Mode-Reg0	7..0	Setting parameters for individual bits
07H	06H	Mode-Reg0-S	15..8	
08H		Mode-Reg1-S	7..0	
09H		Mode-Reg1-R	7..0	
0AH		WD Baud Ctrl -Val	7..0	Root value for baud rate monitoring
0BH		MinTsdr_Val	7..0	MinTsdr time
OCH				
0DH		Reserved		
0EH				
0FH				
10H				
11H				
12H				
13H				
14H				
15H				

Figure 4.3: Assignment of the Internal Parameter Latches for WRITE

4.3 Organizational Parameters (RAM)

The user stores the organizational parameters in RAM under the specified addresses. These parameters can be written and read.

Address Intel /Motorola	Name	Bit No.	Significance
16H	R_TS_Adr	7..0	Set up station address of the relevant SPC3
17H	reserved		Pointer to a RAM address which is presetted with 0FFH
18H 19H	R_User_Wd_Value	7..0	Based on an internal 16-bit watchdog timer, the user is monitored in the DP_Mode.
19H 18H	R_User_Wd_Value	15 ..8	
1AH	R_Len_Dout_Puf		Length of the 3 Dout buffers
1BH	R_Dout_buf_Ptr1		Segment base address of Dout buffer 1
1CH	R_Dout_buf_Ptr2		Segment base address of Dout buffer 2
1DH	R_Dout_buf_Ptr3		Segment base address of Dout buffer 3
1EH	R_Len_Din_buf		Length of the 3 Din buffers
1FH	R_Din_buf_Ptr1		Segment base address of Din buffer 1
20H	R_Din_buf_Ptr2		Segment base address of Din buffer 2
21H	R_Din_buf_Ptr3		Segment base address of Din buffer 3
22H	reserved		Preset with 00H.
23H	reserved		Preset with 00H.
24H	R Len Diag buf1		Length of Diag buffer 1
25H	R Len Diag buf2		Length of Diag buffer 2
26H	R_Diag_Puf_Ptr1		Segment base address of Diag buffer 1
27H	R_Diag_Puf_Ptr2		Segment base address of Diag buffer 2
28H	R Len Cntrl Pbuf1		Length of Aux buffer 1 and the control buffer belonging to it, for example, SSA-Buf, Prm-Buf, Cfg-Buf, Read-Cfg-Buf
29H	R Len Cntrl Puf2		Length of Aux-Buffer 2 and the control buffer belonging to it, for example, SSA-Buf, Prm-Buf, Cfg-Buf, Read-Cfg-Buf
2AH	R Aux Puf Sel		Bit array, in which the assignments of the Aux-buffers ½ are defined to the control buffers, SSA-Buf, Prm-Buf, Cfg-Buf
2BH	R_Aux_buf_Ptr1		Segment base address of auxiliary buffer 1
2CH	R_Aux_buf_Ptr2		Segment base address of auxiliary buffer 2
2DH	R_Len_SSA_Data		Length of the input data in the Set_Slave_Address-buffer
2EH	R SSA buf Ptr		Segment base address of the Set_Slave_Address-buffer
2FH	R_Len_Prm_Data		Length of the input data in the Set_Param-buffer
30H	R_Prm_buf_Ptr		Segment base address of the Set_Param-buffer
31H	R_Len_Cfg_Data		Length of the input data in the Check_Config-buffer
32H	R Cfg Buf Ptr		Segment base address of the Check_Config-buffer
33H	R_Len_Read_Cfg_Data		Length of the input data in the Get_Config-buffer
34H	R_Read_Cfg_buf_Ptr		Segment base address of the Get_Config-buffer
35H	reserved		Preset with 00H.
36H	reserved		Preset with 00H
37H	reserved		Preset with 00H.
38H	reserved		Preset with 00H.
39H	R_Real_No_Add_Change		This parameter specifies whether the DP slave address may again be changed at a later time point.
3AH	R_Ident_Low		The user sets the parameters for the Ident_Low value.
3BH	R_Ident_High		The user sets the parameters for the Ident_High value.
3CH	R_GC_Command		The Global_Control_Command last received
3DH	R_Len_Spec_Prm_buf		If parameters are set for the Spec_Prm_Buffer_Mode (see mode register 0), this cell defines the length of the param buffer.

Figure 4.4: Assignment of the Organizational Parameters

5 ASIC Interface

The registers that determine both the hardware function of the ASIC as well as telegram processing are described in the following.

5.1 Mode Register

Parameter bits that access the controller directly or which the controller directly sets are combined in two mode registers (0 and 1) in the SPC3.

5.1.1 Mode Register 0

Setting parameters for Mode Register 0 takes place in the offline state only (for example, after switching on). The SPC3 may not exit *offline* until Mode Register 0, all processor parameters, and organizational parameters are loaded (START_SPC3 = 1, Mode-Register 1).

Address Control Register	Bit Position								Designation
	7	6	5	4	3	2	1	0	
06H (Intel)	Freeze_ Support- ed	Sync_ Support- ed	EARLY_ RDY	INT_ POL	MinTSDR		DIS_ STOP_ CON TROL	DIS_ START_ CON TROL	Mode Reg0 7..0

Address Control Register	Bit Position								Designation
	15	14	13	12	11	10	9	8	
07H (Intel)			Spec_Cle ar_Mode (*)	Spec_Prm_ Puf_Mode (**)	WD Test	User Time base	EOI Time base	DP Mode	Mode-Reg0 13 .. 8

*) When Spec_Clear_Mode (Fail Safe Mode) = 1 the SPC3 will accept data telegram with a data unit=0 in the state Data Exchange. The reaction to the outputs can be parameterized f.e. in the parameterization telegram (only available from version Step C).

**) When using a big number of parameters to be transmitted from the PROFIBUS-Master to the slave the Auxiliary buffer ½ has to have the same size like the Parameterization buffer. Sometimes this could reach the limit of the available memory space in the SPC3. When Spec_Prm_Puf_Mode = 1 the parameterization data are processed directly in this special buffer and the Auxiliary buffers can be held compact.

Bit 0	DIS_START_CONTROL
	Monitoring the following start bit in UART. Set-Param Telegram overwrites this memory cell in the DP mode. (Refer to the user-specific data.) 0 = Monitoring the following start bit is enabled. 1 = Monitoring the following start bit is switched off.
Bit 1	DIS_STOP_CONTROL
	Stop bit monitoring in UART. Set-Param telegram overwrites this memory cell in the DP mode. (Refer to the user-specific data.) 0 = Stop bit monitoring is enabled. 1 = Stop bit monitoring is switched off.
Bit 2	EN_FDL_DDB
	Reserved 0 = The FDL_DDB receive is disabled.
Bit 3	MinTSDR
	Default setting for the MinTSDR after reset for DP operation or combi operation 0 = Pure DP operation (default configuration!) 1 = Combi operation
Bit 4	INT_POL
	Polarity of the interrupt output 0 = The interrupt output is low-active. 1 = The interrupt output is high-active.
Bit 5	EARLY_RDY
	Moved up ready signal 0 = Ready is generated when the data are valid (read) or when the data are accepted (write). 1 = Ready is moved up by one clock pulse.
Bit 6	Sync_Supported
	Sync_Mode support 0 = Sync_Mode is not supported. 1 = Sync_Mode is supported.
Bit 7	Freeze_Supported
	Freeze_Mode support 0 = Freeze_Mode is not supported. 1 = Freeze_Mode is supported.
Bit 8	DP_MODE
	DP_Mode enable 0 = DP_Mode is disabled. 1 = DP_Mode is enabled. SPC3 sets up all DP_SAPs.
Bit 9	EOI_Time base
	Time base for the end of interrupt pulse 0 = The interrupt inactive time is at least 1 usec long. 1 = The interrupt inactive time is at least 1 ms long.
Bit 10	User_Time base
	Time base for the cyclical User_Time_Clock-Interrupt 0 = The User_Time_Clock-Interrupt occurs every 1 ms. 1 = The User_Time_Clock-Interrupt occurs every 10 ms.
Bit 11	WD_Test
	Test mode for the Watchdog-Timer, no function mode 0 = The WD runs in the function mode. 1 = Not permitted
Bit 12	Spec_Prm_Puf_Mode
	Special parameter buffer 0 = No special parameter buffer. 1 = Special parameter buffer mode .Parameterization data will be stored directly in the special parameter buffer.
Bit 13	Spec_Clear_Mode
	Special Clear Mode (Fail Safe Mode) 0 = No special clear mode. 1 = Special clear mode. SPC3 will accept data telegrams with data unit = 0.

Figure 5.1: Mode-Register 0 Bit 12 .. 0.(can be written to, can be changed in offline only)

5.1.2 Mode Register 1 (Mode-REG1, writable):

Some control bits must be changed during operation. These control bits are combined in Mode-Register 1 and can be set independently of each other (Mode_Reg_S) or can be deleted independently of each other (Mode_Reg_R). Various addresses are used for setting and deleting. Log '1' must be written to the bit position to be set or deleted.

Address Control Register	Bit Position								Designation
	7	6	5	4	3	2	1	0	
08H			Res_ User_WD	EN_ Change_ Cfg_ Puffer	User_ Leave_ Master	Go_ Offline	EOI	START_ SPC3	Mode-Reg_S 7..0
09H			Res_ User_WD	EN_ Change_ Cfg_ Puffer	User_ Leave_ Master	Go_ Offline	EOI	START_ SPC3	Mode-Reg_R 7..0

Bit 0	START_SPC3
	Exiting the <i>Offline state</i> 1 = SPC3 exits <i>offline</i> and goes to <i>passive-idle</i> . In addition, the idle timer and Wd timer are started and 'Go_Offline = 0' is set.
Bit 1	EOI
	End of Interrupt 1 = End of Interrupt: SPC3 switches the interrupt outputs to inactive and again sets EOI to log.'0.'
Bit 2	Go_Offline
	Going into the offline state 1 = After the current requests ends, SPC3 goes to the <i>offline state</i> and again sets Go_Offline to log.'0.'
Bit 3	User_Leave_Master
	Request to the DP_SM to go to 'Wait_Prm.' 1 = The user causes the DP_SM to go to 'Wait_Prm.' After this action, SPC3 sets User_Leave_Master to log.'0.'
Bit 4	En_Change_Cfg_Puffer
	Enabling buffer exchange (Cfg buffer for Read_Cfg buffer) 0 = With 'User_Cfg_Data_Okay_Cmd,' the Cfg buffer may not be exchanged for the Read_Cfg buffer. 1 = With 'User_Cfg_Data_Okay_Cmd,' the Cfg buffer must be exchanged for the Read_Cfg buffer.
Bit 5	Res_User_Wd
	Resetting the User_WD_Timers 1 = SPC3 again sets the User_Wd_Timer to the parameterized value 'User_Wd_Value15..0.' After this action, SPC3 sets Res_User_Wd to log.'0.'

Figure 5..2: Mode Register1 S and Mode Register1 R Bit7..0.(writable)

5.2 Status Register

The status register mirrors the current SPC3 status and can be read only.

Address Control Register	Bit Position								Designation
	7	6	5	4	3	2	1	0	
04H (Intel)	WD_State		DP_State		RAM access violation	Diag_ Flag	FDL_ IND_ST	Offline/ Passive- Idle	Status-Reg 7..0
	1	0	1	0					

Address Control Register	Bit Position								Designation
	15	14	13	12	11	10	9	8	
05H (Intel)	SPC3 Release				Baud Rate				Status-Reg 15 .. 8
	3	2	1	0	3	2	1	0	

Bit 0	Offline/Passive-Idle
	Offline-/Passive-Idle state
	0 = SPC3 is in offline. 1 = SPC3 is in passive idle.
Bit 1	FDL_IND_ST
	FDL indication is temporarily buffered.
	0 = No FDL indication is temporarily buffered. 1 = No FDL indication is temporarily buffered.
Bit 2	Diag_Flag
	Status diagnostics buffer
	0 = The DP master fetches the diagnostics buffer. 1 = The DP master has not yet fetched the diagnostics buffer.
Bit 3	RAM Access Violation
	Memory access > 1.5kByte
	0 = No address violation 1 = For addresses > 1536 bytes, 1024 is subtracted from the current address, and there is access to this new address.
Bits 4,5	DP-State1..0
	DP-State Machine state
	00 = 'Wait_Prm' state 01 = 'Wait_Cfg' state 10 = 'DATA_EX' state 11 = Not possible
Bits 6,7	WD-State1..0
	Watchdog-State-Machine state
	00 = 'Baud_Search' state 01 = 'Baud_Control' state 10 = 'DP_Control' state 11 = Not possible
Bits 8,9 10,11	Baud rate3..0:
	The baud rates SPC3 found
	0000 = 12 MBaud 0001 = 6 MBaud 0010 = 3 MBaud 0011 = 1.5 MBaud 0100 = 500 kBaud 0101 = 187.5 kBaud 0110 = 93.75 kBaud 0111 = 45.45 kBaud 1000 = 19.2 kBaud 1001 = 9.6 kBaud Rest = Not possible
Bit 12 13,14, 15	SPC3-Release3..0:
	Release no. for SPC3
	0000 = Release 0 Rest = Not possible

Figure 5.3: Status Register Bit15 .. 0.(readable)

5.3 Interrupt Controller

The processor is informed about indication messages and various error events via the interrupt controller. Up to a total of 16 events are stored in the interrupt controller. The events are carried out on an interrupt output. The controller does not have a prioritization level and does not provide an interrupt vector (not 8259A compatible!).

The controller consists of an Interrupt Request Register (IRR), an Interrupt Mask Register (IMR), an Interrupt Register (IR), and an Interrupt Acknowledge Register (IAR).

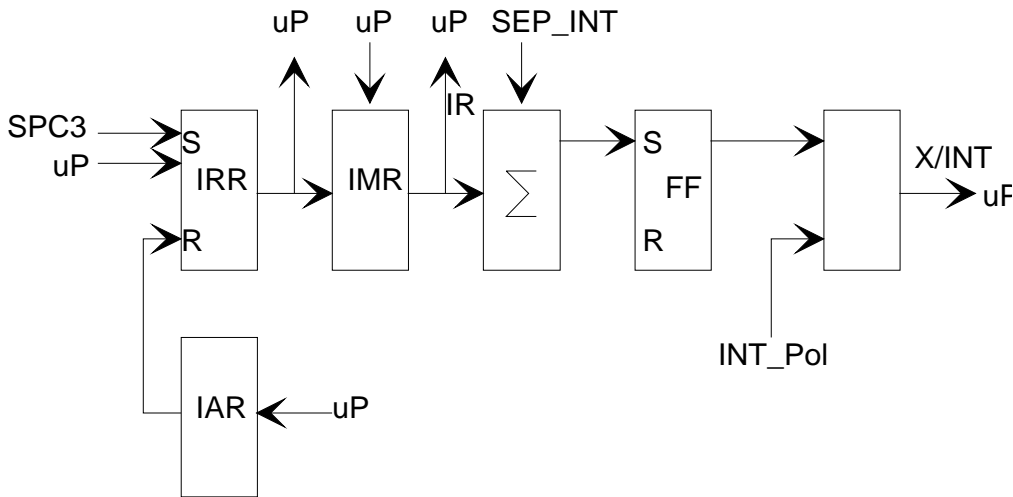

Each event is stored in the IRR. Individual events can be suppressed via the IMR. The input in the IRR is independent of the interrupt masks. Event signals not masked out in the IMR generate the X/INT interrupt via a sum network. The user can set each event in the IRR for debugging.

Each interrupt event the processor processed must be deleted via the IAR (except for New_Prm_Data, New_DDB_Prm_Data, and New_Cfg_Data). Log '1' must be written on the relevant bit position. If a new event and an acknowledge from the previous event are present at the IRR at the same time, the event remains stored. If the processor subsequently enables a mask, it must be ensured that no prior input is present in the IRR. For safety purposes, the position in the IRR must be deleted prior to the mask enable.

Prior to exiting the interrupt routine, the processor must set the "end of interrupt signal (EOI) = 1" in the mode register. The interrupt cable is switched to inactive with this edge change. If another event must be stored, the interrupt output is not activated again until after an interrupt inactive time of at least 1 usec or 1-2 ms. This interrupt inactive time can be set via 'EOI_Timebase.' This makes it possible to again come into the interrupt routine when an edge-triggered interrupt input is used.

The polarity for the interrupt output is parameterized via the INT_Pol mode bit. After the hardware reset, the output is low-active.

Address Control Register	Bit Position								Designation
	7	6	5	4	3	2	1	0	
00H (Intel)	Res	Res	Res	User_Timer_Clock	WD_DP_Mode_Timeout	Baud_rate_Detect	Go/Leave Data_EX	MAC_Reset	Int-Req-Reg 7..0

Address Control Register	Bit Position								Designation
	15	14	13	12	11	10	9	8	
01H (Intel)	Res	Res	DX_OUT	Diag_Puffer_Changed	New_Prm_Data	New_Cfg_Data	New_SSA_Data	New_GC Com mand	Int-Req-Reg 7 15..8

Bit 0	MAC_Reset After it processes the current request, the SPC3 has arrived at the <i>offline state</i> (through setting the 'Go_Offline bit' or through a RAM access violation).
Bit 1	Go/Leave_DATA_EX The DP_SM has entered or exited the 'DATA_EX' state.
Bit 2	Baudrate_Detect The SPC3 has exited the 'Baud_Search state' and found a baud rate.
Bit 3	WD_DP_Control_Timeout The watchdog timer has run out in the 'DP_Control' WD state.
Bit 4	User_Timer_Clock The time base for the User_Timer_Clocks has run out (1/10ms).
Bit 5	Res For additional functions
Bit 6	Res For additional functions
Bit 7	Res For additional functions
Bit 8	New_GC_Command The SPC3 has received a 'Global_Control telegram' with a changed 'GC_Command-Byte,' and this byte is stored in the 'R_GC_Command' RAM cell.
Bit 9	New_SSA_Data The SPC3 has received a 'Set_Slave_Address telegram' and made the data available in the SSA buffer.
Bit 10	New_Cfg_Data The SPC3 has received a 'Check_Cfg telegram' and made the data available in the Cfg buffer.
Bit 11	New_Prm_Data The SPC3 has received a 'Set_Param telegram' and made the data available in the Prm buffer.
Bit 12	Diag_Puffer_Changed Due to the request made by 'New_Diag_Cmd,' SPC3 exchanged the diagnostics buffer and again made the old buffer available to the user.
Bit 13	DX_OUT The SPC3 has received a 'Write_Read_Data telegram' and made the new output data available in the N buffer. For a 'Power_On' or for a 'Leave_Master,' the SPC3 deletes the N buffer and also generates this interrupt.
Bit 14	Res For additional functions
Bit 15	Res For additional functions

Figure 5.4: Interrupt Request Register, IRR Bit 15..0 (writable and readable)

The other interrupt controller registers are assigned in the bit positions, like the IRR.

Address	Register		Reset State	Assignment	
02H / 03H	Interrupt Register (IR)	Readable only	All bits deleted		
04H / 05H	Interrupt Mask Register (IMR)	Writable, can be changed during operation	All bits set	Bit = 1 Bit = 0	Mask is set and the interrupt is disabled. Mask is deleted and the interrupt is enabled.
02H / 03H	Interrupt Acknowledge Register (IAR)	Writable, can be changed during operation	All bits deleted	Bit = 1 Bit = 0	The IRR bit is deleted. The IRR bit remains unchanged.

Figure 5.5: Additional Interrupt Registers

The 'New_Prm_Data', 'New_Cfg_Data' inputs may not be deleted via the Interrupt Acknowledge Register. The relevant state machines delete these inputs through the user acknowledgements (for example, 'User_Prm_Data_Okay' etc.).

5.4 Watchdog Timer

5.4.1 Automatic Baud Rate Identification

The SPC3 is able to identify the baud rate automatically. The „baud search“ state is located after each RESET and also after the watchdog (WD) timer has run out in the 'Baud_Control_state.'

As a rule, SPC3 begins the search for the set rate with the highest baud rate. If no SD1 telegram, SD2 telegram, or SD3 telegram was received completely and without errors during the monitoring time, the search continues with the next lowest baud rate.

After identifying the correct baud rate, SPC3 switches to the "Baud_Control" state and monitors the baud rate. The monitoring time can be parameterized (WD_Baud_Control_Val). The watchdog works with a clock of 100 Hz (10 msec). The watchdog resets each telegram received with no errors to its own station address. If the timer runs out, SPC3 again switches to the baud search state.

5.4.2 Baud Rate Monitoring

The located baud rate is **constantly** monitored in 'Baud_Control.' The watchdog is reset for each error-free telegram to its own station address. The monitoring time results from multiplying both 'WD_Baud_Control_Val' (user sets the parameters) by the time base (10 ms). If the monitoring time runs out, WD_SM again goes to 'Baud_Search'. If the user carries out the DP protocol (DP_Mode = 1, see Mode register 0) with SPC3, the watchdog is used for the "DP_Control" state, after a 'Set_Param telegram' was received with an enabled response time monitoring 'WD_On = 1.' The watchdog timer remains in the baud rate monitoring state when there is a switched off 'WD_On = 0' master monitoring. The PROFIBUS DP state machine is also not reset when the timer runs out. That is, the slave remains in the DATA_EXchange state, for example.

5.4.3 Response Time Monitoring

The 'DP_Control' state serves response time monitoring of the DP master (Master_Add). The set monitoring times results from multiplying both watchdog factors and multiplying the result with the momentarily valid time base (1 ms or 10 ms):

$$T_{WD} = (1 \text{ ms or } 10 \text{ ms}) * WD_Fact_1 * WD_Fact_2 \text{ (See byte 7 of the parameter setting telegram.)}$$

The user can load the two watchdog factors (WD_Fact_1, and WD_Fact_2) and the time base that represents a measurement for the monitoring time via the 'Set_Param telegram' with any value between 1 and 255.

EXCEPTION: The WD_Fact_1=WD_Fact_2=1 setting is not permissible. The circuit does not check this setting.

Monitoring times between 2 ms and 650 s - independent of the baud rate - can be implemented with the permissible watchdog factors.

If the monitoring time runs out, the SPC3 goes again to 'Baud_Control,' and the SPC3 generates the 'WD_DP_Control_Timeout-Interrupt'. In addition, the DP_State machine is reset, that is, generates the reset states of the buffer management.

If another master accepts SPC3, then there is either a switch to 'Baud_Control" (WD_On = 0), or there is a delay in 'DP_Control' (WD_On = 1), depending on the enabled response time monitoring (WD_On = 0).

6 PROFIBUS-DP Interface

6.1 DP_Buffer Structure

The DP mode is enabled in the SPC3 with 'DP_Mode = 1' (see mode Register0). In this process, the following SAPS are fixed reserved for the DP mode:

Default SAP:	Data exchange (Write_Read_Data)
SAP53:	reserved
SAP55:	Changing the station address (Set_Slave_Address)
SAP56:	Reading the inputs (Read_Inputs)
SAP57:	Reading the outputs (Read_Outputs)
SAP58:	Control commands to the DP-Slave (Global_Control)
SAP59:	Reading configuration data (Get_Config)
SAP60:	Reading diagnostics information (Slave_Diagnosis)
SAP61:	Sending parameter setting data (Set_Param)
SAP62:	Checking configuration data (Check_Config)

The DP Slave protocol is completely integrated in the SPC3 and is handled independently. The user must correspondingly parameterize the ASIC and process and acknowledge transferred messages. Except for the default SAP, SAP56, SAP57, and SAP58, all SAPS are always enabled. The remaining SAPS are not enabled until the the DP Slave Machine (DP_SM) goes into the 'DATA_EX' state. The user has the possibility of disabling SAP55. The relevant buffer pointer R_SSA_Puf_Ptr must be set to '00H' for this purpose. The DDB utility is disabled by the already described initialization of the RAM cells.

The DP_SAP buffer structure is displayed in Figure 6.1. The user configures all buffers (length and buffer beginning) in the 'offline state.' During operation, the buffer configuration must not be changed, except for the length of the Dout-/Din buffers.

The user may still adapt these buffers in the 'Wait_Cfg' state after the configuration telegram (Check_Config). **Only the same configuration may be accepted in the 'DATA_EX' state.**

The buffer structure is divided into the data buffer, diagnostics buffer, and the control buffer.

Both the output data and the input data have three buffers each available with the same length. These buffers function as change buffers. One buffer is assigned to the 'D' data transfer, and one buffer is assigned to the 'U' user. The third buffer is either in a Next 'N' state or Free 'F' state, whereby one of the two states is always unoccupied.

Two diagnostics buffers that can have varying lengths are available for diagnostics. One diagnostics buffer is always the 'D' assigned to SPC3 for sending. The other diagnostics buffer belongs to the user for preparing new diagnostics data, 'U.'

The SPC3 first reads the different parameter setting telegrams (Set_Slave_Address, and Set_Param) and the configuring telegram (Check_Config) into Aux-Puffer1 or Aux-Puffer 2.....

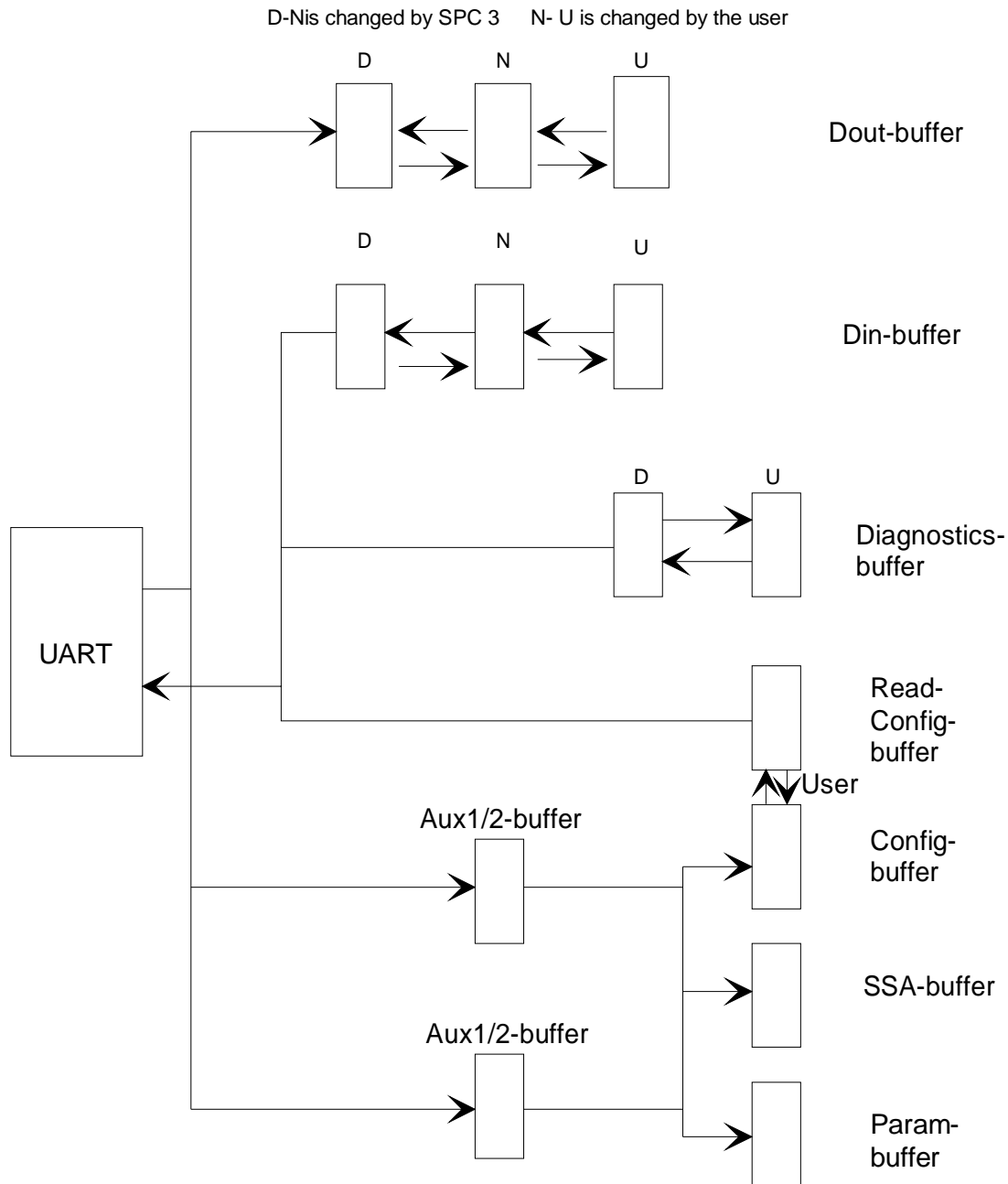

Figure 6.1: DP_SAP Buffer Structure

Data exchanged with the corresponding target buffer (SSA buffer, Prm buffer, and Cfg buffer). Each of the buffers to be exchanged must have the same length. The user defines which Aux_buffers are to be used for the above-named telegrams in the 'R_Aux_Puf_Sel' parameter cell. The Aux-buffer1 must always be available. The Aux-buffer2 is optional. If the data profiles of these DP telegrams are very different, such as the data amount in the Set_Param telegram is significantly larger than for the other telegrams, it is suggested to make an Aux-Buffer2 available (Aux_Sel_Set_Param = 1) for this telegram. The other telegrams are then read via Aux-Buffer 1 (Aux_Sel_..=0). If the buffers are too small, SPC3 responds with "no resources"!

Address RAM Register	Bit Position							Designation	
	7	6	5	4	3	2	0		
2AH	0	0	0	0	0	Set_ Slave_ Adr	Check_ Cfg	Set_ Prm	R_Aux_Puf_Sel
						X1	X1	X1	See below for coding.

X1	Coding
0	Aux_Buffer1
1	Aux_Buffer2

Figure 6.2: Aux-Buffer Management

The user makes the configuration data (Get_Config) available in the Read_Cfg buffer for reading. The Read_Cfg buffer must have the same length as the Cfg_buffer.

The Read_Input_Data telegram is operated from the Din buffer in the 'D state', and the Read_Output_Data telegram is operated from the Dout buffer in the 'U state.'

All buffer pointers are 8-bit segment addresses, because the SPC3 internally has only 8-bit address registers. For a RAM access, SPC3 adds an 8-bit offset address to the segment address shifted by 3 bits (result: 11-bit physical address). As regards the buffer start addresses, this results in an 8-byte granularity from this specification.

6.2 Description of the DP Services

6.2.1 Set_Slave_Address (SAP55)

6.2.1.1 Sequence for the Set_Slave_Address Utility

The user can disable this utility by setting the 'R_SSA_Puf_Ptr = 00H' buffer pointer. The slave address must then be determined, for example, by reading a switch, and written in the R_TS_Adr. RAM register.

The user must make a retentive memory possibility available (for example, EEPROM) to support this utility. It must be possible to store the 'station address' and the 'Real_No_Add_Change' ('True' = FFH) parameter in this external EEPROM. After each restart caused by a power failure, the user must again make these values available to SPC3 in the R_TS_Adr und R_Real_No_Add_Change RAM register.

If SAP55 is enabled and the Set_Slave_Address telegram is correctly accepted, SPC3 enters all net data in the Aux-Puffer1/2, exchanges the Aux buffer1/2 for the SSA buffer, stores the entered data length in 'R_Len_SSA_Data', generates the 'New_SSA_Data' interrupt and internally stores the new 'station address' and the new 'Real_No_Add_Change' parameter. The user does not need to transfer this changed parameter to SPC3 again. After the user has read the buffer, the user generates the 'SSA_Puffer_Free_Cmd' (read operation on address 14H). This makes SPC3 again ready to receive an additional Set Slave Address telegram (such as from another master).

SPC3 reacts independently when there are errors.

Address Control Register	Bit Position								Designation
	7	6	5	4	3	2	1	0	
14H	0	0	0	0	0	0	0	0	SSA_Puffer_Free_Cmd
	don't care								

Figure 6.3: Coding SSA_Buffer_Free_Cmd

6.2.1.2 Structure of the Set_Slave_Address Telegram

The net data are stored as follows in the SSA buffer:

Byte	Bit Position								Designation
	7	6	5	4	3	2	1	0	
0									New_Slave_Address
1									Ident_Number_High
2									Ident_Number_Low
3									No_Add_Chg
4-243									Rem_Slave_Data additional application-specific data

Figure 6.4: Data Format for the Set_Slave_Address Telegram

6.2.2 Set_Param (SAP61)

6.2.2.1 Parameter Data Structure

SPC3 evaluates the first seven data bytes (without user prm data), or the first eight data bytes (with user prm data). The first seven bytes are specified according to the standard. The eighth byte is used for SPC3-specific characteristics. The additional bytes are available to the application.

Byte	Bit Position								Designation
	7	6	5	4	3	2	1	0	
0	Lock Req	Unlo. Req	Sync Req	Free Req	WD on	Res	Res	Res	Station status
1									WD_Fact_1
2									WD_Fact_2
3									MinTSDR
4									Ident_Number_High
5									Ident_Number_Low
6									Group_Ident
7	0	0	0	0	0	WD_Base	Dis Stop	Dis Start	Spec_User_Prm_Byte
8-243									User_Prm_Data

Byte 7 Spec_User_Prm_Byte			
Bit	Name	Significance	Default State
0	Dis_Startbit	The start bit monitoring in the receiver is switched off with this bit.	Dis_Startbit= 1 , that is, start bit monitoring is switched off.
1	Dis_Stopbit	Stop bit monitoring in the receiver is switched off with this bit.	Dis_Stopbit= 0, that is, stop bit monitoring is not switched off.
2	WD_Base	This bit specifies the time base used to clock the watchdog. WD_Base = 0: time base 10 ms WD_Base = 1: time base 1 ms	WD_Base= 0, that is, the time base is 10 ms
3-7	res	to be parameterized with 0	0

Figure 6.5: Data Format for the Set_Param_Telegram

6.2.2.2 Parameter Data Processing Sequence

In the case of a positive validation for more than seven data bytes, SPC3 carries out the following reaction, among others:

SPC3 exchanges Aux-Puffer1/2 (all data bytes are input here) for the Prm buffer, stores the input data length in 'R_Len_Prm_Data', and triggers the 'New_Prm_Data Interrupt'. The user must then check the 'User_Prm_Data' and either reply with the 'User_Prm_Data_Okay_Cmd' or with 'User_Prm_Data_Not_Okay_Cmd.' The entire telegram is input in the buffer, that is, application-specific parameter data are stored beginning with data byte 8 only.

The user response (User_Prm_Data_Okay_Cmd or User_Prm_Data_Not_Okay_Cmd) again takes back the 'New_Prm_Data' interrupt. The user may not acknowledge the 'New_Prm_Data' interrupt in the IAR register.

The relevant diagnostics bits are set with the 'User_Prm_Data_Not_Okay_Cmd' message and are branched to 'Wait_Prm.'

The 'User_Prm_Data_Okay' and 'User_Prm_Data_Not_Okay' acknowledgements are reading accesses to defined registers with the relevant signals:

- 'User_Prm_Finished': No additional parameter telegram is present.
- 'Prm_Conflict' : An additional parameter telegram is present, processing again
- 'Not_Allowed', Access not permitted in the current bus state

Address Control Register	Bit Position								Designation
	7	6	5	4	3	2	1	0	
0EH	0	0	0	0	0	0	↓	↓	User_Prm_Data_Okay
							0	0	User_Prm_Finished
							0	1	PRM_Conflict
							1	1	Not_Allowed

Address Control Register	Bit Position								Designation
	7	6	5	4	3	2	1	0	
0FH	0	0	0	0	0	0	↓	↓	User_Prm_Data_Not_Okay
							0	0	User_Prm_Finished
							0	1	PRM_Conflict
							1	1	Not_Allowed

Figure 6.6: Coding User_Prm_Data_Not/_Okay_Cmd

If an additional Set-Param telegram is supposed to be received in the meantime, the signal 'Prm_Conflict' is returned for the acknowledgement of the first Set_Param telegram, whether positive or negative. Then the user must repeat the validation because the SPC3 has made a new Prm buffer available.

6.2.3 Check_Config (SAP62)

The user takes on the evaluation of the configuration data. After SPC3 has received a validated Check_Config-Telegram, SPC3 exchanges the Aux-Puffer1/2 (all data bytes are entered here) for the Cfg buffer, stores the input data length in 'R_Len_Cfg-Data,' and generates 'New_Cfg_Data-Interrupt'.

The user must then check the 'User_Config_Data' and either respond with 'User_Cfg_Data_Okay_Cmd' or with 'User_Cfg_Data_Not_Okay_Cmd' (acknowledgement to the Cfg_SM). The net data is input in the buffer in the format regulation of the standard.

The user response (User_Cfg_Data_Okay_Cmd or the User_Cfg_Data_Not_Okay_Cmd response) again takes back the 'New_Cfg_Data' interrupt and may not be acknowledged in the IAR.

If an incorrect configuration is signalled back, various diagnostics bits are changed, and there is branching to 'Wait_Prm.'

For a correct configuration, the transition to 'DATA_EX' takes place immediately, if no Din_buffer is present (R_Len_Din_Puf = 00H) and trigger counters for the parameter setting telegrams and configuration telegrams are at 0. Otherwise, the transition does not take place until the first 'New_DIN_Puffer_Cmd' with which the user makes the first valid 'N buffer' available. When entering into 'DATA_EX,' SPC3 also generates the 'Go/Leave_Data_Exchange-Interrupt'.

If the received configuration data from the Cfg buffer are supposed to result in a change of the Read-Cfg-buffer (the change contains the data for the Get_Config telegram), the user must make the new Read_Cfg data available in the Read-Cfg buffer before the 'User_Cfg_Data_Okay_Cmd' acknowledgement. After receiving the acknowledgement, SPC3 exchanges the Cfg buffer with the Read-Cfg buffer, if 'EN_Change_Cfg_buffer = 1' is set in mode register1.

During the acknowledgement, the user receives information about whether there is a conflict or not. If an additional Check_Config telegram was supposed to be received in the meantime, the user receives the 'Cfg_Conflict' signal during the acknowledgement of the first Check_Config telegram, whether positive or negative. Then the user must repeat the validation, because SPC3 has made a new Cfg buffer available.

The 'User_Cfg_Data_Okay_Cmd' and 'User_Cfg_Data_Not_Okay_Cmd' acknowledgements are read accesses to defined memory cells (see Section 2.2.1) with the relevant 'Not_Allowed', 'User_Cfg_Finished,' or 'Cfg_Conflict' signals (see Figure 3.7). **If the 'New_Prm_Data' and 'New_Cfg_Data' are supposed to be present simultaneously during power up, the user must maintain the Set_Param and then the Check_Config. acknowledgement sequence.**

Address Control Register	Bit Position								Designation
	7	6	5	4	3	2	1	0	
10H	0	0	0	0	0	0	↓	↓	User_Cfg_Data_Okay
							0	0	User_Cfg_Finished
							0	1	Cfg_Conflict
							1	1	Not_Allowed

Address Control Register	Bit Position								Designation
	7	6	5	4	3	2	1	0	
11H	0	0	0	0	0	0	↓	↓	User_Cfg_Data_Not_Okay
							0	0	User_Cfg_Finished
							0	1	Cfg_Conflict
							1	1	Not_Allowed

Figure 6.7: Coding of the User_Cfg_Data_Not/_Okay_Cmd

6.2.4 Slave_Diagnosis (SAP60)

6.2.4.1 Diagnostics Processing Sequence

Two buffers are available for diagnostics. The two buffers can have varying lengths. SPC3 always has one diagnostics buffer assigned to it, which is sent for a diagnostics call-up. The user can pre-process new diagnostics data in parallel in the other buffer. If the new diagnostics data are to be sent now, the user uses the 'New_Diag_Cmd' to make the request to exchange the diagnostics buffers. The user receives confirmation of the exchange of the buffers with the 'Diag_Puffer_Changed Interrupt.'

When the buffers are exchanged, the internal 'Diag_Flag' is also set. For an activated 'Diag_Flag,' SPC3 responds during the next Write_Read_Data with high-priority response data that signal the relevant master that new diagnostics data are present at the slave. Then this master fetches the new diagnostics data with a Slave_Diagnosis telegram. Then the 'Diag_Flag' is reset again. If the user signals 'Diag.Stat_Diag = 1,' however (static diagnosis, see the structure of the diagnostics buffer), then 'Diag_Flag' still remains activated after the relevant master has fetched the diagnosis. The user can poll the 'Diag_Flag' in the status register to find out whether the master has already fetched the diagnostics data before the old data is exchanged for the new data.

Status coding for the diagnostics buffers is stored in the 'Diag_bufferSM' processor parameter. The user can read this cell with the possible codings for both buffers: 'User,' 'SPC3,' or 'SPC3_Send_Mode.'

Address Control Register	Bit Position								Designation
	7	6	5	4	3	2		0	
0CH	0	0	0	0	D_Puf2	D_Puf1			Diag_Puffer_SM
					X1	X2	X1	X2	See below for coding.

X1	X2	Coding
0	0	Each for the D_Buf2 or D_Buf1
0	1	User
1	0	SPC3
1	1	SPC3_Send_Mode

Figure 6.8: Diag_Buffer Assignment

The 'New_Diag_Cmd' is also a read access to a defined processor parameter with the signal as to which diagnostics buffer belongs to the user after the exchange, or whether both buffers are currently assigned to SPC3 ('no Puffer', 'Diag_Puf1', 'Diag_Puf2').

Address Control Register	Bit Position								Designation
	7	6	5	4	3	2	1	0	
0DH	0	0	0	0	0	0	↓	↓	New_Diag_Cmd
							0	0	no Puffer
							0	1	Diag_Puf1
							1	0	Diag_Puf2

Figure 6.9: Coding Diag_Puffer_SM, New_Diag_Cmd

6.2.4.2 Structure of the Diagnostics Buffer:

The user transfers the diagnostics buffer displayed in the figure below to SPC3. The first 6 bytes are space holders, except for the three least significant bit positions in the first byte. The user stores the diagnostics bits, 'Diag.Ext_Diag' 'Diag.Stat_Diag,' and Diag.Ext.Diag_Overflow' in these three bit positions. The remaining bits can be assigned in any order. When sending, SPC3 pre-processes the first six bytes corresponding to the standard.

Byte	Bit Position								Designation
	7	6	5	4	3	2	1	0	
0						Ext_ Diag Over f	Stat Diag	Ext_ Diag	Spaceholder
1									Spaceholder
2									Spaceholder
3									Spaceholder
4									Spaceholder
5									Spaceholder
6-n	The user must input								Ext_Diag_Data (n = max 243)

Figure 6.10: Structure of the Diagnostics Buffer for Transfer to the SPC3

The 'Ext-Diag_Data' the user must enter into the buffers follow after the SPC3-internal diagnostics data. The three different formats are possible here (device-related, ID-related, and port-related). In addition to the 'Ext_Diag_Data,' the buffer length also includes the SPC3 diagnostics bytes (R_Len_Diag_Puf1, R_Len_Diag_Puf2).

6.2.5 Write_Read_Data / Data Exchange (Default_SAP)

6.2.5.1 Writing Outputs

SPC3 reads the received output data in the D buffer. After error-free receipt, SPC3 shifts the newly filled buffer from 'D' to 'N.' In addition, the 'DX_Out_Interrupt' is generated. The user now fetches the current output data from 'N.' The buffer changes from 'N' to 'U' with the 'Next_Dout_Buffer_Cmd,' so that the current data of the application can be sent back for the master's Read_Outputs.

If the user's evaluation cycle time is shorter than the bus cycle time, the user does not find any new buffers with the next 'Next_Dout_Buffer_Cmd' in 'N.' Therefore, the buffer exchange is omitted. At a 12 Mbd baud rate, it is more likely, however, that the user's evaluation cycle time is larger than the bus cycle time. This makes new output data available in 'N' several times before the user fetches the next buffer. It is guaranteed, however, that the user receives the data last received.

For 'Power_On', 'Leave_Master' and the Global_Control-Telegram 'Clear,' SPC3 deletes the D buffer and then shifts it to 'N.' This also takes place during the power up (entering into 'Wait_Prm'). If the user fetches this buffer, he receives the 'U_buffer cleared' display during the 'Next_Dout_Buffer_Cmd.' If the user is still supposed to enlarge the output data buffer after the Check_Config telegram, the user must delete this delta in the N buffer himself (possible only during the power-up phase in the 'Wait_Cfg' state).

If 'Diag.Sync_Mode = 1', the D buffer is filled but not exchanged with the Write_Read_Data-Telegram, but rather exchanged at the next Sync or Unsync.

The user can read the buffer management state with the following codes for the four states: 'Nil', 'Dout_Puf_Ptr1-3'. The pointer for the current data is in the "N" state.

Address Control Register	Bit Position								Designation
	7	6	5	4	3	2		0	
0AH	F		U		N		D		Dout_Puffer_SM
	X1	X2	X1	X2	X1	X2	X1	X2	See below for coding.

X1	X2	Coding
0	0	Nil
0	1	Dout_Puf_Ptr1
1	0	Dout_Puf_Ptr2
1	1	Dout_Puf_Ptr3

Figure 6.11: Dout_Buffer Management

When reading the 'Next_Dout_Buffer_Cmd' the user gets the information which buffer (U-buffer) belongs to the user after the change, or whether a change has taken place at all.

Address Control Register	Bit Position								Designation
	7	6	5	4	3	2	1	0	
0BH	0	0	0	0	U_ Buffer Cleared	State_ U_ Buffer	Ind_U_ Buffer		Next_Dout_Buf_Cmd
							0	1	Dout_Buf_Ptr1
							1	0	Dout_Buf_Ptr2
							1	1	Dout_Buf_Ptr3
							0		No new U buffer
							1		New U buffer
					0				U buffer contains data
					1				U buffer was deleted

Figure 6.12: Next_Dout_Puffer_Cmd

The user must delete the U buffer during initialization so that defined (deleted) data can be sent for a Read_Output Telegram before the first data cycle.

6.2.5.2 Reading Inputs

SPC3 sends the input data from the D buffer. Prior to sending, SPC3 fetches the Din buffer from 'N' to 'D.' If no new buffer is present in 'N,' there is no change.

The user makes the new data available in 'U'. With the 'New_Din_buffer_Cmd,' the buffer changes from 'U' to 'N'. If the user's preparation cycle time is shorter than the bus cycle time, not all new input data are sent, but just the most current. At a 12 Mbd baud rate, it is more probable, however, that the user's preparation cycle time is larger than the bus cycle time. Then SPC3 sends the same data several times in succession.

During start-up, SPC3 first goes to 'DATA_EX' after all parameter telegrams and configuration telegrams are acknowledged, and the user then makes the first valid Din buffer available in 'N' with the 'New_Din_Buffer_Cmd.'

If 'Diag.Freeze_Mode = 1', there is no buffer change prior to sending.

The user can read the status of the state machine cell with the following codings for the four states: 'Nil', 'Dout_Puf_Ptr1-3.' (See Figure 3.13.) The pointer for the current data is in the "N" state.

Address Control Register	Bit Position								Designation
	7	6	5	4	3	2		0	
08H	F		U		N		D		Din_Buffer_SM
	X1	X2	X1	X2	X1	X2	X1	X2	See below for coding.

X1	X2	Coding
0	0	Nil
0	1	Din_Buf_Ptr1
1	0	Din_Buf_Ptr2
1	1	Din_Buf_Ptr3

Figure 6.13: Din_Buffer Management

When reading the 'New_Din_Buffer_Cmd' the user gets the information which buffer (U-buffer) belongs to the user after the change (Din_Buf_Ptr 1-3).

Address Control Register	Bit Position								Designation
	7	6	5	4	3	2	1	0	
09H	0	0	0	0	0	0	↓	↓	New_Din_Buf_Cmd
							0	1	Din_Buf_Ptr1
							1	0	Din_Buf_Ptr2
							1	1	Din_Buf_Ptr3

Figure 6.14: Next_Din_Buffer_Cmd

6.2.5.3 User_Watchdog_Timer

After power-up ('DATA_EX' state), it is possible that SPC3 continually answers Write_Read_Data-telegrams without the user fetching the received Din buffers or making new Dout buffers available. If the user processor 'hangs up,' the master would not receive this information. Therefore, a 'User_Watchdog_Timer' is implemented in SPC3.

This User_Wd_Timer is an internal 16-bit RAM cell that is started from a 'R_User_Wd_Value15..0' value the user parameterizes and is decremented with each received Write_Read_Data telegram from SPC3. If the timer attains the '0000hex' value, SPC3 transitions to the 'Wait_Prm' state, and the DP_SM carries out a 'Leave_Master.' The user must cyclically set this timer to its start value. Therefore, 'Res_User_Wd = 1' must be set in mode register 1. Upon receipt of the next Write_Read_Data telegram, SPC3 again loads the User_Wd_Timer to the parameterized value 'R_User_Wd_Value15..0' and sets 'Res_User_Wd = 0' (Mode Register 1). During power-up, the user must also set 'Res_User_Wd = 1', so that the User_Wd_Timer is even set at its parameterized value.

6.2.6 Global_Control (SAP58)

SPC3 itself processes the Global_Control-Telegrams in the manner already described. In addition, this information is available to the user.

The first byte of a valid Global_Control command is stored in the R_GC_Command RAM cell. The second telegram byte (Group_Select) is processed internally.

Address RAM Cell	Bit Position								Designation
	7	6	5	4	3	2	1	0	
3CH	Res	Res	Sync	Un sync	Freeze	Un freeze	Clear_ Data	Res	R_GC_Command

Bit	Designation	Significance
0	Reserved	
1	Clear_Data	With this command, the output data is deleted in 'D' and is changed to 'N.'
2	Unfreeze	With „Unfreeze,“ freezing input data is cancelled.
3	Freeze	The input data is fetched from 'N' to 'D' and „frozen“. New input data is not fetched again until the master sends the next 'Freeze' command.
4	Unsync	The „Unsync“ command cancels the „Sync“ command.
5	Sync	The output data transferred with a WRITE_READ_DATA telegram is changed from 'D' to 'N.' The following transferred output data is kept in 'D' until the next 'Sync' command is given.
6,7	Reserved	The „Reserved“ designation specifies that these bits are reserved for future function expansions.

Figure 6.15: Data Format for the Global_Control Telegram

If the Control_Command byte changed at the last received Global_Control telegram, SPC3 additionally generates the 'New_GC_Command' interrupt. During initialization, SPC3 presets the 'R_GC_Command' RAM cell with 00H. The user can read and evaluate this cell.

So that Sync and Freeze can be carried out, these functions must be enabled in the mode register.

6.2.7 Read_Inputs (SAP56)

SPC3 fetches the input data like it does for the Write_Read_Data Telegram. Prior to sending, 'N' is shifted to 'D,' if new input data are available in 'N.' For 'Diag.Freeze_Mode = 1,' there is no buffer change.

6.2.8 Read_Outputs (SAP57)

SPC3 fetches the output data from the Dout buffer in 'U'. The user must preset the output data with '0' during start-up so that no invalid data can be sent here. If there is a buffer change from 'N' to 'U' (through the Next_Dout_Buffer_Cmd) between the first call-up and the repetition, the new output data is sent during the repetition.

6.2.9 Get_Config (SAP59)

The user makes the configuration data available in the Read_Cfg buffer. For a change in the configuration after the Check_Config telegram, the user writes the changed data in the Cfg buffer, sets 'EN_Change_Cfg_buffer = 1' (see Mode-Register1), and SPC3 then exchanges the Cfg buffer for the Read_Cfg buffer. (See Section 3.2.3.) If there is a change in the configuration data (for example, for the modular DP systems) during operation, the user must return with 'Go Offline' (see Mode Register1) to 'Wait_Prm' to SPC3.

7 Hardware Interface

7.1 Universal Processor Bus Interface

7.1.1 General Description

SPC3 has a parallel 8-bit interface with an 11-bit address bus. SPC3 supports all 8-bit processors and microcontrollers based on the 80C51/52 (80C32) from Intel, the Motorola HC11 family, as well as 8-/16-bit processors or microcontrollers from the Siemens 80C166 family, X86 from Intel, and the HC16 and HC916 family from Motorola. Because the data formats from Intel and Motorola are not compatible, SPC3 automatically carries out 'byte swapping' for accesses to the following 16-bit registers (interrupt register, status register, and mode register0) and the 16-bit RAM cell (R-User_Wd_Value). This makes it possible for a Motorola processor to read the 16-bit value correctly. Reading or writing takes place, as usual, through two accesses (8-bit data bus).

Due to the 11-bit address bus, SPC3 is no longer fully compatible to SPC2 (10-bit address bus). However, AB(10) is located on the XINTCI output of the SPC2 that was not used until now. For SPC3, the AB(10) input is provided with an internal pull-down resistor. If SPC3 is to be connected into existing SPC2 hardware, the user can use only 1 kByte of the internal RAM. Otherwise, the AB(10) cable on the modules must be moved to the same place.

The Bus Interface Unit (BIU) and the Dual Port RAM Controller (DPC) that controls accesses to the internal RAM belong to the processor interface of the SPC3.

In addition, a clock rate divider is integrated that the clock pulse of an external clock pulse generator divided by 2 (Pin: DIVIDER = High-Potential) or 4 (Pin: DIVIDER = Low-Potential) makes available on the pin CLKOUT2/4 as the system clock pulse so that a slower controller can be connected without additional expenditures in a low-cost application. SPC3 is supplied with a clock pulse rate of 48MHz.

7.1.2 Bus Interface Unit (BIU)

The BIU forms the interface to the connected processor/microcontroller. This is a synchronous or asynchronous 8-bit interface with an 11-bit address bus. The interface is configurable via 2 pins (XINT/MOT, MODE). The connected processor family (bus control signals such as XWR, XRD, or R_W, and the data format) is specified with the XINT/MOT pin. Synchronous (rigid) or asynchronous bus timing is specified with the MODE pin.

Various Intel system configurations are displayed in the figures in Section 7.1.3. The internal address latch and the integrated decoder must be used in the C32 mode. One figure displays the minimum configuration of a system with SPC3, whereby the block is connected to an EPROM version of the controller. Only a pulse generator is necessary as an additional block in this configuration. If a controller is to be used without an integrated program memory, the addresses must once again be latched off for the external memory. The connection schematic in the next figure is applicable for all Intel/Siemens processors that offer asynchronous bus timing and evaluate the ready signal.

Notes:

If the **SPC3 is connected to an 80286** processor, or others, it must be taken into consideration that the processor carries out word accesses. That is, either a "swapper" is necessary that switches the characters out of the SPC3 at the relevant byte position of the 16-bit data bus during reading, or the least significant address bit is not connected, and the 80286 must read word accesses and evaluate only the lower byte, as displayed in the figure.

XINT/MO	MODE	The SPC3 interface supports the following processors/microcontrollers.
1 synchron-ous Motorola	1	Motorola microcontroller with the following characteristics: <ul style="list-style-type: none"> • Synchronous (rigid) bus timing without evaluation of the XREADY signal • 8-bit non-multiplexed bus: DB7..0, AB10..0
		The following can be connected: <ul style="list-style-type: none"> • HC11 types: K, N, M, F1 • HC16- und HC916 types with programmable E clock timing • All other HC11 types with a multiplexed bus must select addresses AB7..0 externally from DB7..0 data.
		The address decoder is switched off in the SPC3. The CS signal is fed to SPC3. <ul style="list-style-type: none"> • For microcontrollers with chip select logic (K, F1, HC16, and HC916), the chip select signals are programmable as regards the address range, the priority, the polarity, and the window width in the write cycle or read cycle. • For microcontrollers without chip select logic (N and M), and others, an external chip select logic is required. This means additional hardware and a fixed assignment.
		Condition: <ul style="list-style-type: none"> • The SPC3 output clock (CLKOUT2/4) must be four times larger than the E_CLOCK. The SPC3 input clock (CLK) must be at least 10 times larger than the desired system clock (E_Clock). The divider pin must be placed at „low“ (divider 4), and it results in an E_CLOCK of 3 MHz
1 asynchron-ous Motorola	0	Motorola microcontroller with the following characteristics: <ul style="list-style-type: none"> • Asynchronous bus timing with evaluation of the XREADY signal • 8-bit non-multiplexed bus: DB7..0, AB10..0
		The following can be connected: <ul style="list-style-type: none"> • HC16 and HC916 types • All other HC11 types with a multiplexed bus must externally select addresses AB7..0 from data DB7..0.
		The address decoder is switched off in SPC3. The CS signal is fed into SPC3. <ul style="list-style-type: none"> • Chip select logic is available and programmable in all microcontrollers.
0 synchron-ous Intel	1	Intel microcontroller CPU basis is 80C51/52/32, microcontrollers from various manufacturers: <ul style="list-style-type: none"> • Synchronous (rigid) bus timing without evaluation of the XREADY signal • 8-bit multiplexed bus: ADB7..0
		The following can be connected: <ul style="list-style-type: none"> • Microcontroller families from Intel, Siemens, and Philips, for example
		The address decoder is switched on in SPC3. The CS signal is generated for SPC3 internally. <ul style="list-style-type: none"> • The lower address bits AB7..0 are stored with the ALE signal in an internal address latch. The internal CS decoder is activated in SPC3 that generates its own CS signal from the AB10..0 addresses. • The internal address decoder is fixed wired, so that SPC3 must always be addressed under the fixed addresses AB7..0 = 00000xxx. SPC3 selects relevant address window from the AB2..0 signals. In this mode, the CS-Pin (XCS) must be located at VDD (high potential).
0 asynchron. Intel	1	Intel- and Siemens 16-/8-bit microcontroller families <ul style="list-style-type: none"> • Asynchronous bus timing with evaluation of the XREADY signal • 8 bit non-multiplexed bus: DB7..0, AB10..0
		The following can be connected: <ul style="list-style-type: none"> • Microcontroller families from Intel x86 and Siemens 80C16x, for example
		Address decoder is switched off in SPC3. The CS signal is fed in to the SPC3. <ul style="list-style-type: none"> • External address decoding is always necessary. • External chip select logic if the microcontroller is not present

Figure 7.1: Bus Interface

7.1.3 Switching Diagram Principles

Low Cost System with 80C32

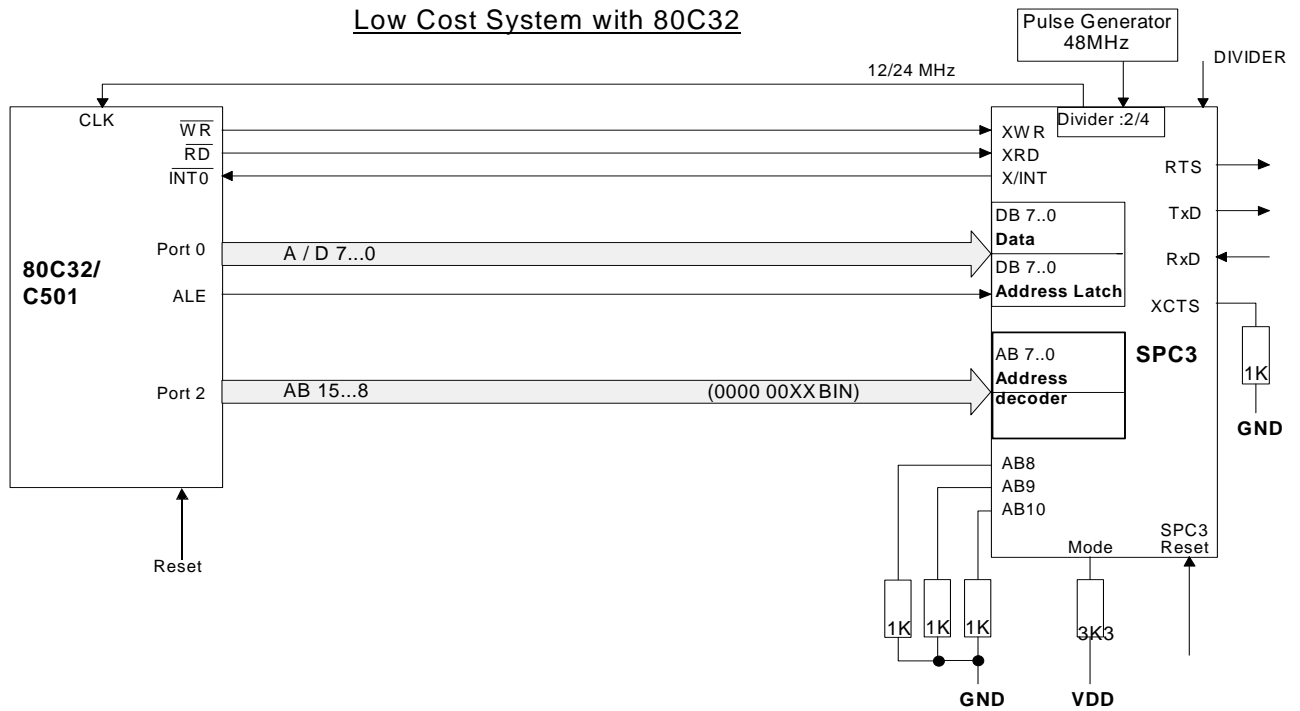

80C32 System with Ext. Memory (C32-Mode)

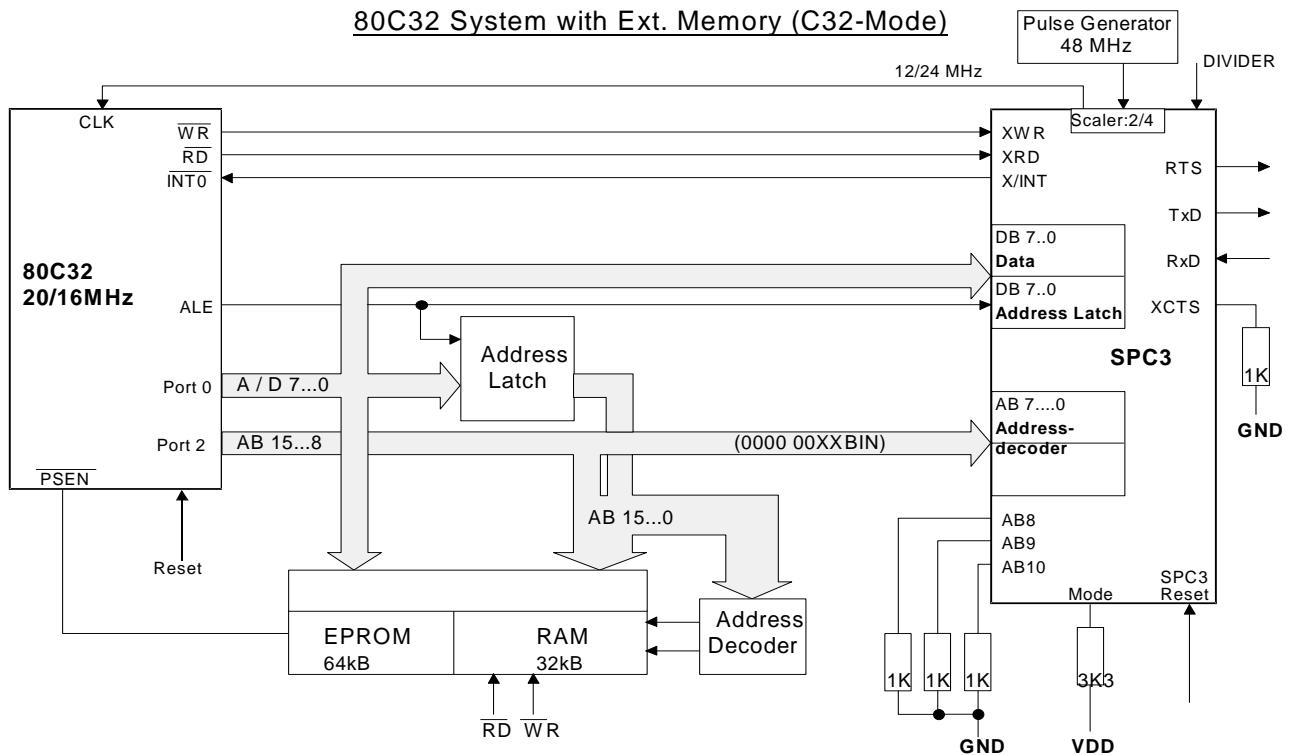

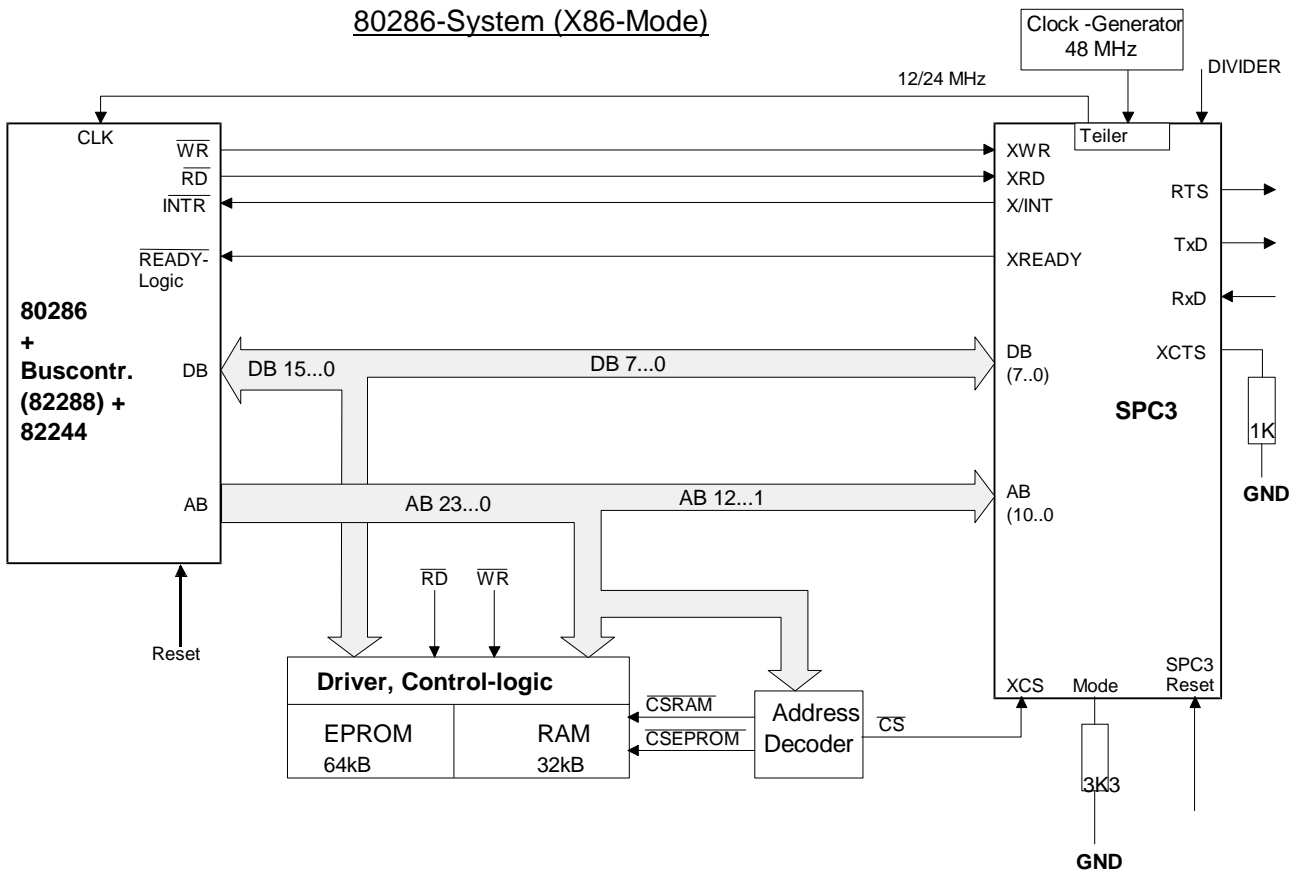

7.1.4 Application with the 80 C 32

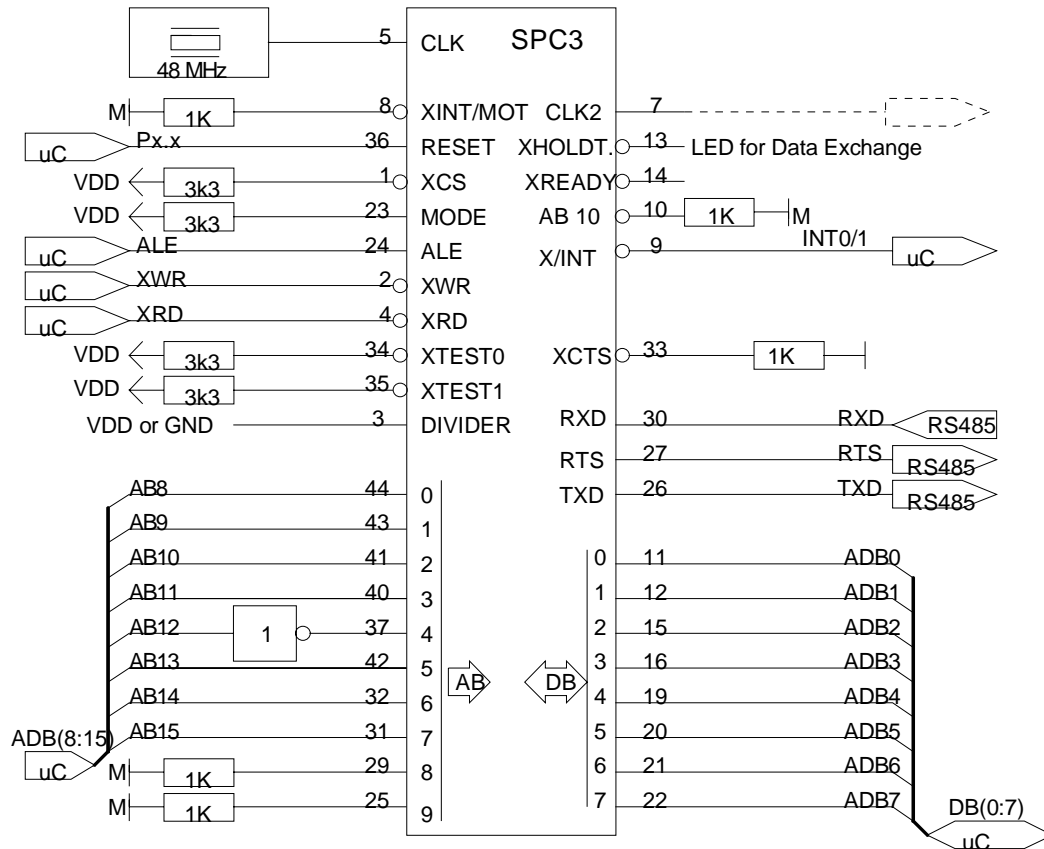

The pull up / pull down resistances in the drawing above are only relevant for a in circuit tester. The internal chip select logic is activated when the address pins A 11 .. A 15 are set to „0“. In the example above the starting address of the SPC3 is set to 0x1000 .

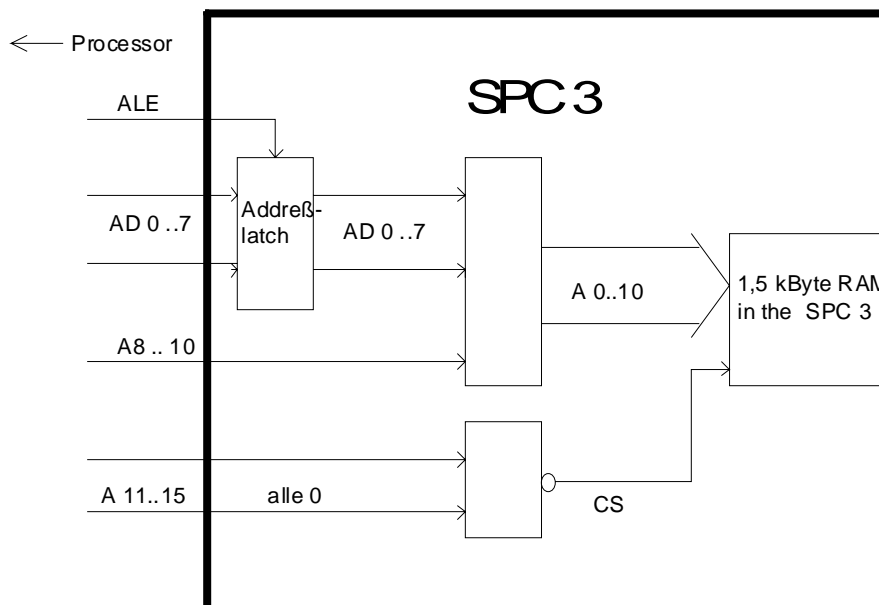

7.1.5 Application with th 80 C 165

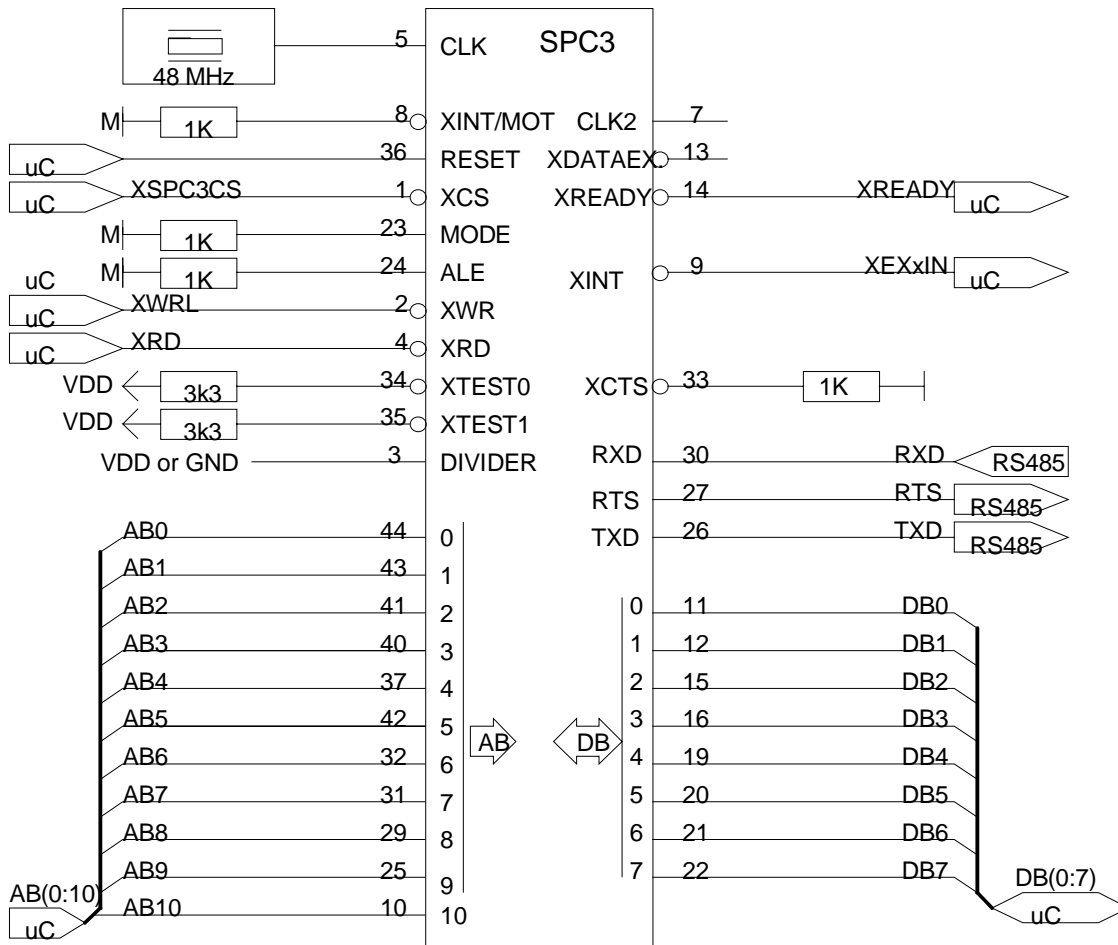

The pull up / pull down resistances in the drawing above are only relevant for a in circuit tester.

Dual Port RAM Controller

The internal 1.5k RAM of the SPC3 is a Single Port RAM. Due to an integrated Dual Port RAM controller, the controller, however, permits an almost simultaneous access of both ports (bus interface and microsequencer interface). When there is a simultaneous access of both ports, the bus interface has priority. This provides for the shortest possible access time. If SPC3 is connected to a microcontroller with an asynchronous interface, SPC3 can evaluate the Ready signal.

7.1.6 Interface Signals

The data bus outputs are high-resistance during the reset phase. All outputs are switched to high-resistance in the test mode. (See block test.)

Name	Input/Output	Type	Comments
DB(7..0)	I/O	Tristate	High-resistance for RESET
AB(10..0)	I		AB(10) has a pull down resistor.
MODE	I		Setting: syn/async interface
XWR/E_CLOCK	I		Intel: Write /Motorola: E-Clk
XRD/R_W	I		Intel: Read /Motorola: Read/Write
XCS	I		Chip Select
ALE/AS	I		Intel/Motorola: Address Latch Enable
DIVIDER	I		Scaling factor 2/4 for CLKOUT 2/4
X/INT	O	Tristate	Polarity programmable
XRDY/XDTACK	O	Tristate	Intel/Motorola: Ready-Signal
CLK	I		48 MHz
XINT/MOT	I		Setting: Intel/Motorola
CLKOUT2/4	O	Tristate	24/12 MHz
RESET	I	Schmitt-Trigger	Minimum of 4 clock pulse cycles

Figure 7.2: Microprocessor Bus Signals

7.2 UART

The transmitter converts the parallel data structure into a serial data flow. Request-to-Send (RTS) is generated before the first character. The XCTS input is available for connecting a modem. After RTS active, the transmitter must hold back the first telegram character until the XCTS modem activates.

The receiver converts the serial data flow into the parallel data structure. The receiver scans the serial data flow with the four-fold transmission speed. Stop bit testing can be switched off for test purposes („DIS_STOP_CONTROL = 1“, in mode register 0 or ‘Set_Param-Telegram’ for DP). One requirement of the PROFIBUS protocol is that no rest states are permitted between the telegram characters. The SPC3 transmitter ensures that this specification is maintained. This following start bit test is switched off with the parameter setting „DIS_START_CONTROL = 1“ (in mode register 0 or ‘Set_Param telegram’ for DP).

Specified by the four-fold scan, a maximum distortion of the serial input signal of $X = -47\%$ to $y = +22\%$ is permissible.

7.3 ASIC Test

All output pins and I/O pins can be switched in the high-resistance state via the XTEST0 test pin. An additional XTEST1 input is provided (more information upon request) to test the block internally with test automatic devices (not in the target hardware environment!).

Pin No.	Name	Function	
34	XTEST0	VSS (GND)	All outputs high-resistance
		VDD (+3.3V)	Normal SPC3 function
35	XTEST1	VSS (GND)	Various test modes
		VDD (+3.3V)	Normal SPC3 function

Figure 7.3: Test Support

XTEST0 and XTEST1 must be placed on V_{DD} (+3.3V) via external pull-up resistors.

8 Technical Data

8.1 Maximum Limit Values

Parameter	Des.	Min	Max	Unit
Supply Voltage	V_{DD}	-0,3	4 - 4,6	V
Input Voltage	V_I	-0,3	VDD+0,3	V
Input Current	I_I	-10	10	mA
Storage Temperature	T_{Stg}	-55	150	$^{\circ}C$
Ambient Temperature	TA	-40	85	$^{\circ}C$
Lead Temp. (Soldering, 10 sec)	TL		300	$^{\circ}C$

Table 8.1: Maximum Limit Values

8.2 Permitted Operating Values

Parameter	Des.	Min	Max	Unit
Supply Voltage	V_{DD}	3	3,6	V
Input High Voltage	V_{IHC}	2	VDD	V
Input Low Voltage	V_{ILC}	0	0,8	V
Schmitt-Trigger (CMOS)				
Input High Voltage	V_P / V_{IHC}	1,4	2,4	V
Input Low Voltage	V_n / V_{ILC}	0,8	1,6	V
Hysteresis Voltage	V_h	0,3	1,5	V
Schmitt-Trigger (TTL)				
Input High Voltage	V_P / V_{IHC}	1,4	2,4	V
Input Low Voltage	V_n / V_{ILC}	0,8	1,6	V
Hysteresis Voltage	V_h	0,3	1,5	V

Table 8. 2: -Permitted Operating Values

8.3 DC-Spezifikation of the I/O- Drivers

Parameter	Des.	Condition	Min	Max	Unit
Output High Voltage	V_{OH}	$V_{DD}=3.0V$	2,4	k.A.	V
Output Low Voltage	V_{OL}	$V_{DD}=3,0V$	k.A.	0,4	V

Table 8.3: DC-Spezifikation of the I/O- Drivers

Parameter	Des.	Unit	
Eingangskapazität	CIN	5	pF
Ausgangskapazität	COU	5	pF
I/O-Kapazität	CI/O	5	pF

Table 8.4: Capacity of the I/O drivers

Parameter	Des.	0Volt Min	3,3Volt Max	Unit
Eingangsleckstrom	I_i	-1	1	μA
Tristate Ausgangsleckstrom	I_{oz}	-10	10	μA

Table 8.5: Leakage current of the output drivers

8.4 AC-Specification for the Output Drivers

Signal	Driver type		Unit	kap. Last
DB(7:0)	Tristate	6	mA	100pF
TXD	Tristate	6	mA	50pF
RTS	Tristate	9	mA	50pF
X/INT	Tristate	6	mA	50pF
XREADY/XDSACK	Tristate	6	mA	50pF
XDATAEXCH	Tristate	6	mA	50pF
CLKOUT2/4	Tristate	6	mA	100pF

Table 8.6: AC-Spezifikation of the output drivers

8.5 Timing Characteristics

The following is generally applicable: All signals beginning with 'X' are 'low active'. All signal runtimes are based on the capacitive loads specified in the table above.

8.5.1 SYS Bus Interface

Clock Pulse:

No.	Parameter	MIN	MAX	Unit
Clock pulse 48 Mhz :				
1	Clock High Time	6.25	14.6	ns
2	Clock Low Time	6.25	14.6	ns
3	Rise Time		4	ns
4	Fall Time		4	ns

Clock Pulse Timing:

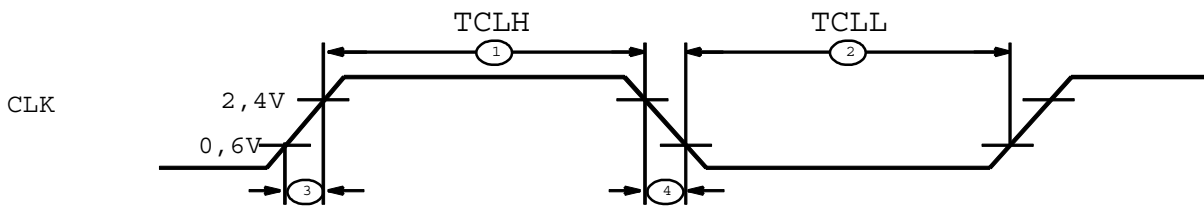

Distortions in the clock pulse signal are permitted up to a ratio of 30:70. At a threshold of 0.6 or 2.4 V:

Interrupts:

No.	Parameter	MIN	MAX	Unit
1	Interrupt Inactive Time (for EO1_Timebase = 0)	1	1	µs
	Interrupt Inactive Time	1	1	ms

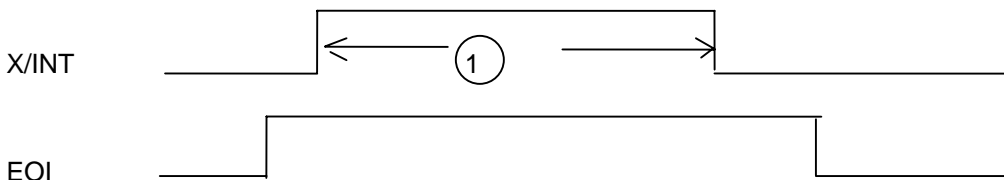

After acknowledging an interrupt with EO1, a min. of 1 us or 1 ms is expected in SPC3 before a new interrupt is output.

Reset:

SPC3 requires a minimum of 400 clock pulse cycles during the reset phase so that it can be reset correctly.

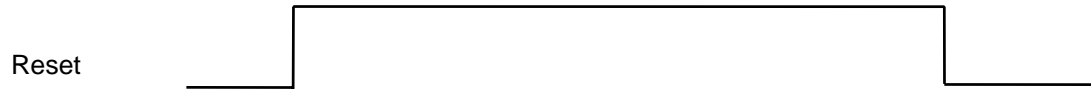

8.5.2 Timing of the Synchronous C32-Mode:

If SPC3 is operated at 48MHz, an 80C32 with a maximum clock pulse rate of 20MHz can be connected.

In the C32 mode, SPC3 saves the least significant addresses with the negative edge of ALE. At the same time, SPC3 expects the more significant address bits on the address bus. SPC3 generates a chipselect signal from the more significant address bits. The request for an access to SPC3 is generated from the negative edge of the read signal and from the positive edge of the write signal.

No.	Parameter	Min	Max	Unit
1	Address to ALE ↓ Setuptime	5		ns
2	Address (AB _{8..15}) Holdtime after XRD ↑ or XWR ↑	5		ns
3	XRD ↓ to Data Out (Zugriff auf RAM)		4T + 5 (88,3)	ns
	XRD ↓ to Data Out (Zugriff auf die Register)		4T + 8 (91,3)	ns
4	ALE ↓ to XRD ↓	20		ns
5	Data Holdtime after XRD ↑	2	5	ns
6	Data Holdtime after XWR ↑	5		ns
7	Data Setuptime to XWR ↑	5		ns
8	XRD ↑ to ALE ↑	10		ns
10	XRD-Pulse-Width	6T - 10		ns
11	XWR-Pulse-Width	4T		ns
12	Address-Holdtime after ALE ↓	5		ns
13	ALE-Puls-Width	10		ns
14	XRD, XWR Cycletime	6T + 30		ns
15	ALE ↓ to XWR ↓	20		ns
16	XWR ↑ to ALE ↑	10		ns

T: Taktperiode (48MHz)

Table 8.7: Timing of the synchronous Intel-Mode

Synchronous Intel-Mode, Processor-Read-Timing

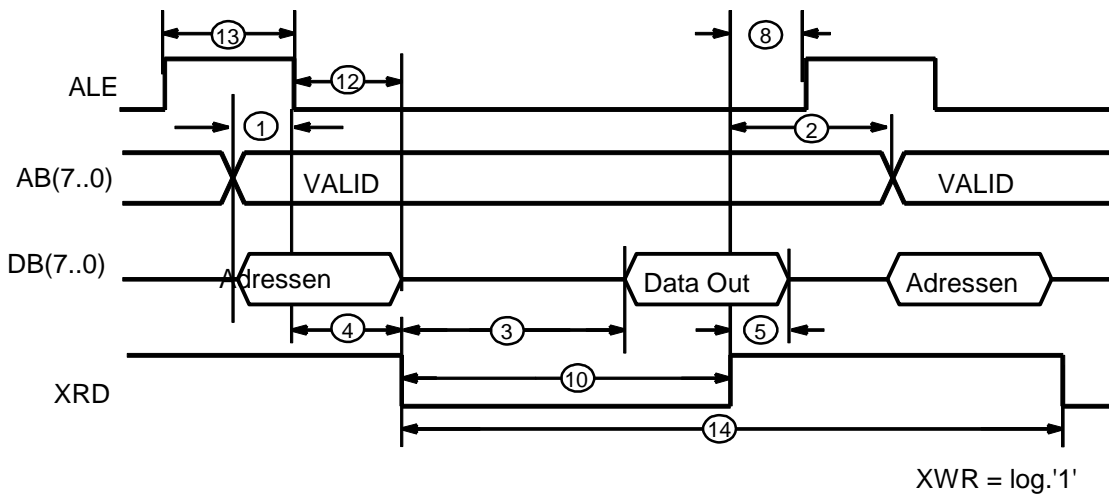

Synchronous Intel-Mode, Processor-Write-Timing

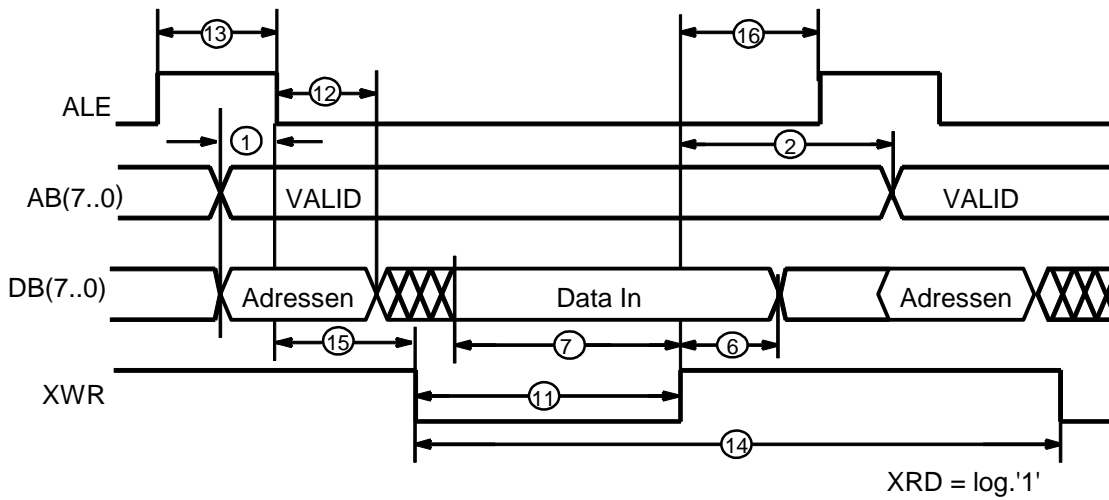

8.5.3 Timing of the Asynchronous Intel Mode (X86 Mode) :

In 80X86 operation, SPC3 acts like memory with ready logic. The access times depend on the type of accesses.

The request for an access to SPC3 is generated from the negative edge of the read signal or the positive edge of the write signal.

SPC3 generates the Ready signal synchronously to the fed in pulse. The Ready signal is reset when the read signal or write signal is deactivated. The data bus is switched to the Tristate with XRD = 1.

No.	Parameter	Min	Max	Unit
20	Address-Setuptime to RXD ↓ or XWR ↓	0		ns
21	XRD ↓ to Data valid (Zugriff auf RAM)		4T+5 (85,5)	ns
	XRD ↓ to Data valid (Zugriff auf die Register)		4T+18 (91,3)	ns
22	Address (AB _{10..0}) Holdtime after XRD or XWR ↑	0		ns
23	XCS ↓ Setuptime to XRD ↓ or XWR ↓	- 5		ns
24	XRD-Puls-Width	6T – 10 (115)		ns
25	Data Holdtime after XRD ↑	2	5	ns
26	Read/Write-Inactive-Time	10		ns
27	XCS Holdtime after XRD ↑ or XWR ↑	0		ns
28	XRD/XWR ↓ to XRDY ↓ (Normal Ready)	4T + 14	5T+ 4	ns
29	XRD/XWR ↓ to XRDY ↓ (Early Ready)	3T + 12	4T+ 4	ns
30	XREADY-Holdtime after XRD or XWR	5	13	ns
31	Data Setuptime to XWR ↑	5		ns
32	Data Holdtime after XWR ↑	5		ns
33	XWR-Pulse-Width *	4T		ns
34	XRD, XWR Cycletime	6T + 30		ns
35	last XRD ↓ to XCS ↓	4T + 10		ns
36	XCS ↑ to next XWR ↑	2T + 10		ns
37	XWR ↑ to next XWR ↑ (XCS don't care)	6T		ns

Table 8.8: Timing of the asynchronous Intel-Mode

Asynchronous Intel-Mode, Processor-Read-Timing

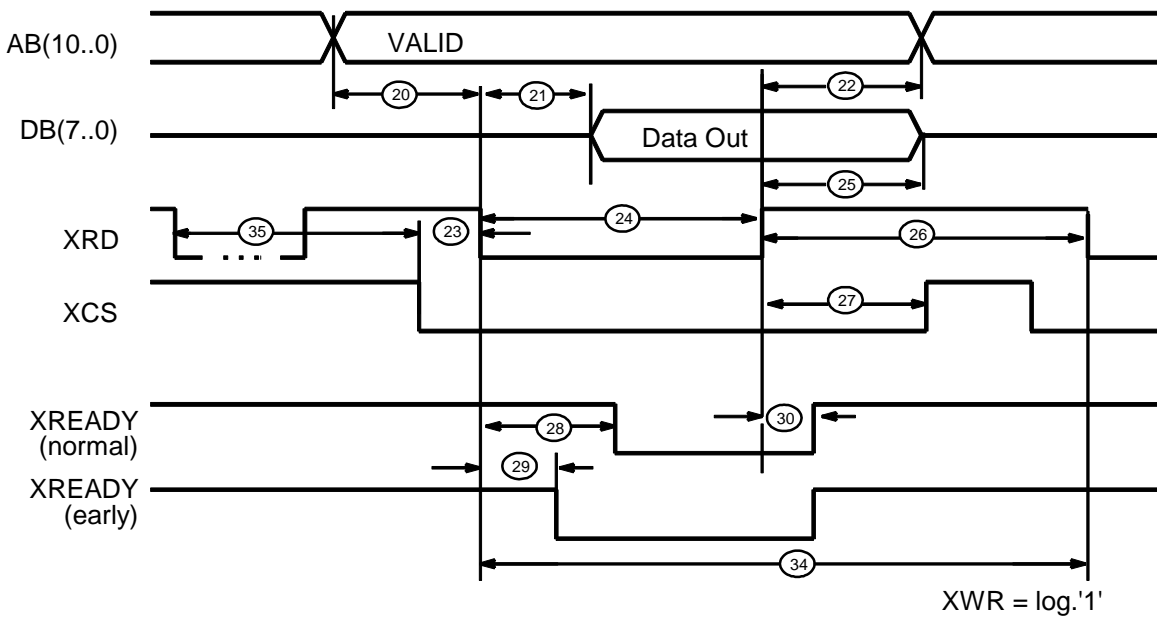

Asynchronous Intel-Mode, Processor-Write-Timing

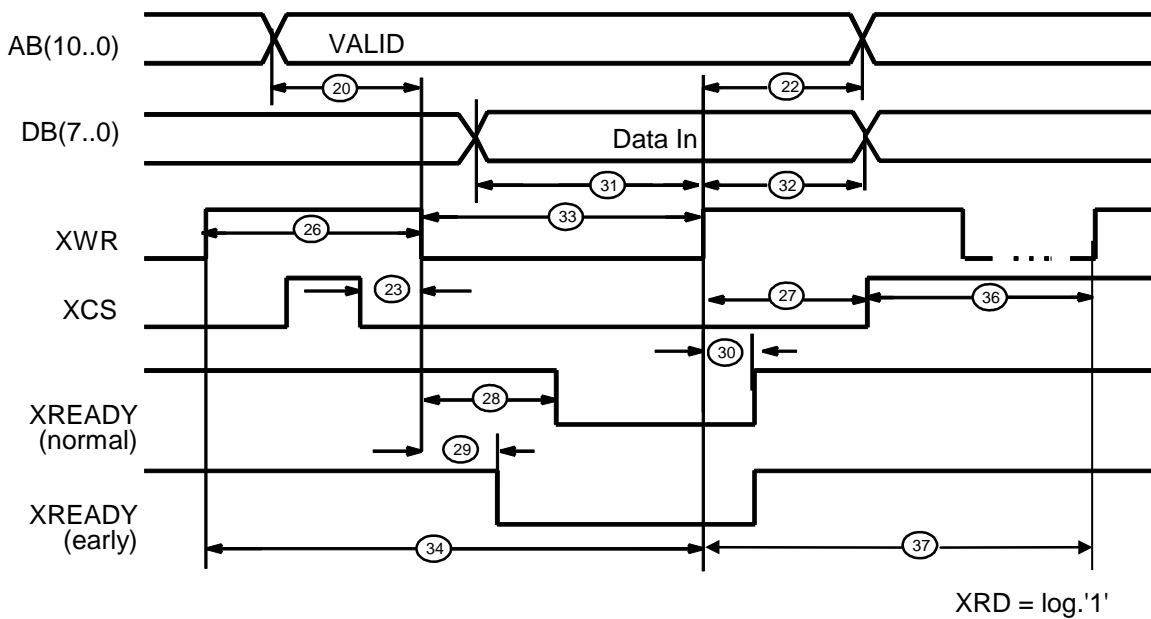

8.5.4 Timing in the Synchronous Motorola Mode (E_Clock-Mode, for example, 68HC11) :

For a CPU clockline through the SPC3, the output clock pulse (CLKOUT2/4) must be 4 times larger than the E_CLOCK. That is, a clock pulse signal must be present at the CLK input that is **at least 10 times** larger than the desired system clock pulse (E_CLOCK). The Divider-Pin must be placed on <log. 0> (divider 4). This results in an E_CLOCK of 3MHz.

The request for a read access to SPC3 is derived from the positive edge of the E clock (in addition: XCS = 0, R W = 1). The request for a write access is derived from the negative edge of the E clock (in addition: XCS = 0, R W = 0).

No.	Parameter	Min	Max	Unit
40	E_Clock-Pulse-Width	$6T + 20$		ns
41	Address (AB _{10..0}) Setuptime to E_Clock ↑	10		ns
42	Address (AB _{10..0}) Holdtime after E_Clock ↓	5		ns
43	E_Clock ↑ to Data Active Delay	5.7	17	ns
44	E_Clock ↑ to Data valid (Zugriff auf RAM)		$4T + 5$ (88,3)	ns
	E_Clock ↑ to Data valid (Zugriff auf die Register)		$4T + 8$ (91,3)	ns
45	Data Holdtime after E_Clock ↓	2	5	ns
46	R_W Setuptime to E_Clock ↑	5		ns
47	R_W Holdtime after E_Clock ↓	5		ns
48	XCS Setuptime to E_Clock ↑	0		ns
49	XCS Holdtime after E_Clock ↓	0		ns
50	Data Setuptime to E_Clock ↓	5		ns
51	Data Holdtime after E_Clock ↓	2		ns

Table 8.9: Timing of the synchronous Motorola-Mode

Synchronous Motorola-Mode, Processor-Read-Timing

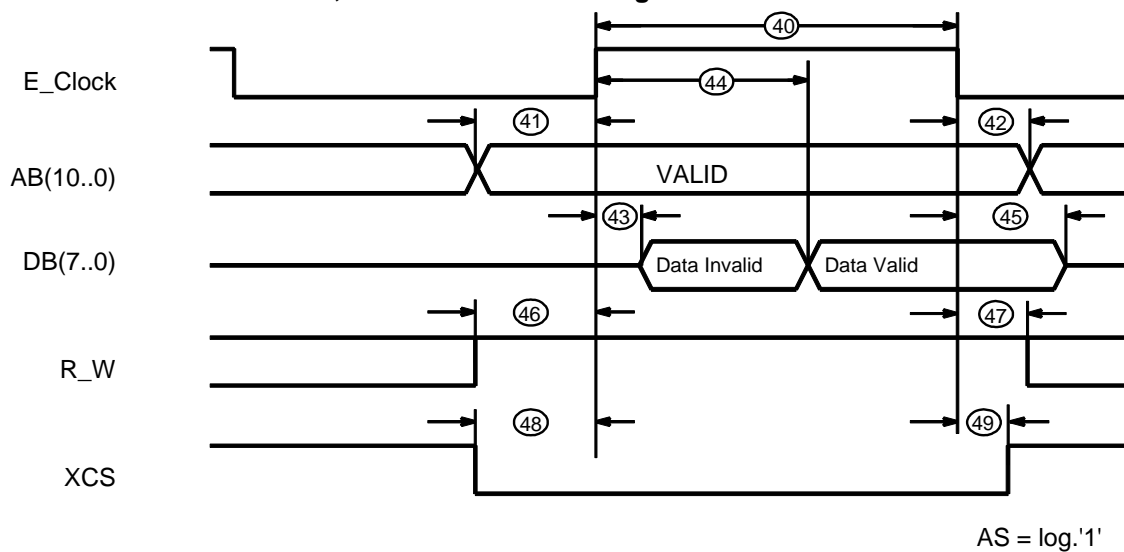

Synchronous Motorola-Mode, Processor-Write-Timing

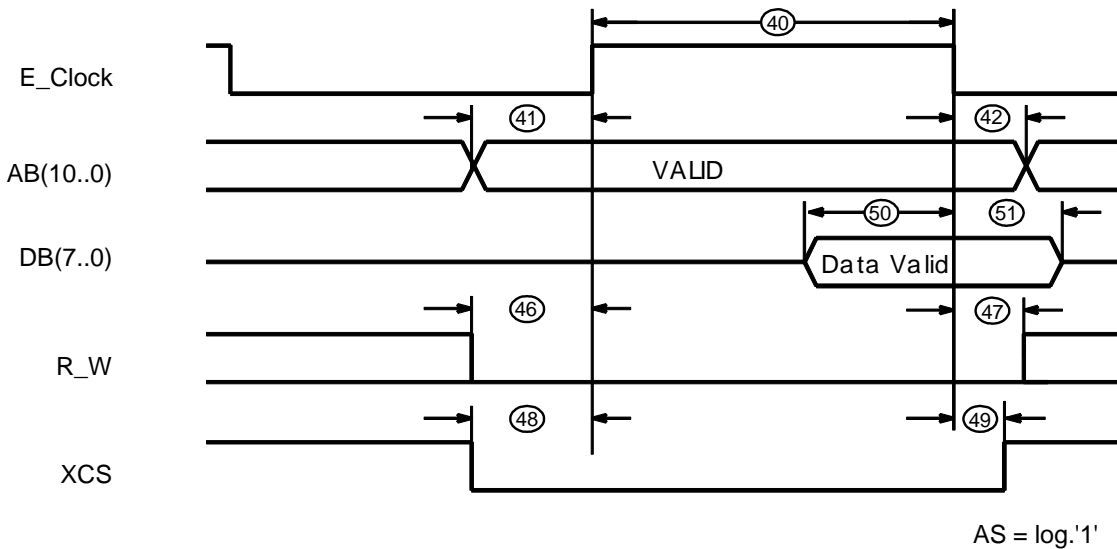

8.5.5 Timing in the Asynchronous Motorola-Mode (for example, 68HC16) :

In the asynchronous Motorola mode, the SPC3 acts like memory with Ready logic, whereby the access times depend on the type of accesses.

The request for an access of SPC3 is generated from the positive edge of the AS signal (in addition: XCS='0', R_W='1'). The request for a write access is generated from the positive edge of the AS signal (in addition: XCS='0', R_W='0').

No.	Parameter	Min	Max	Unit
60	Address-Setuptime to AS ↓	0		ns
61	AS ↓ to Data valid (Zugriff auf RAM)		4T + 5 (88,3)	ns
	AS ↓ to Data valid (Zugriff auf die Register)		4T + 8 (91,3)	ns
62	Address (AB _{10..0}) Holdtime after AS ↑	10		ns
63	R_W ↓ Setuptime to AS ↓	10		ns
64	AS-Puls-Width (Read)	6T - 10		ns
65	Data Holdtime after AS ↑	2	5	ns
66	AS-Inactive-Time	10		ns
67	R_W Holdtime after AS ↑	10		ns
68	XCS ↓ Setuptime to AS ↓	-5		ns
69	XCS Holdtime after AS ↑	0		ns
70	AS ↓ to XDSACK ↓ (Read, Normal Ready)	4T + 16	5T + 4	ns
71	AS ↓ to XDSACK ↓ (Read, Early Ready)	3T + 16	4T + 4	ns
72	XDSACK-Holdtime after AS ↑	5	7.5	ns
73	AS Cycletime (Read)	6T + 30		ns
74	Data Setuptime to AS ↑	4		ns
75	Data Holdtime after AS ↑	2		ns
76	AS-Pulse-Width (Write) *	4T		ns
77	last AS ↓ (Read) to XCS ↓	4T + 10		ns
78	XCS ↑ to next AS ↑ (Write)	2T + 10		Ns
79	AS ↑ to next AS ↑ (Write, XCS don't care)	6T		ns

Table 8.10: Timing of the asynchronous Motorola-Mode

Asynchronous Motorola-Mode, Processor-Read-Timing

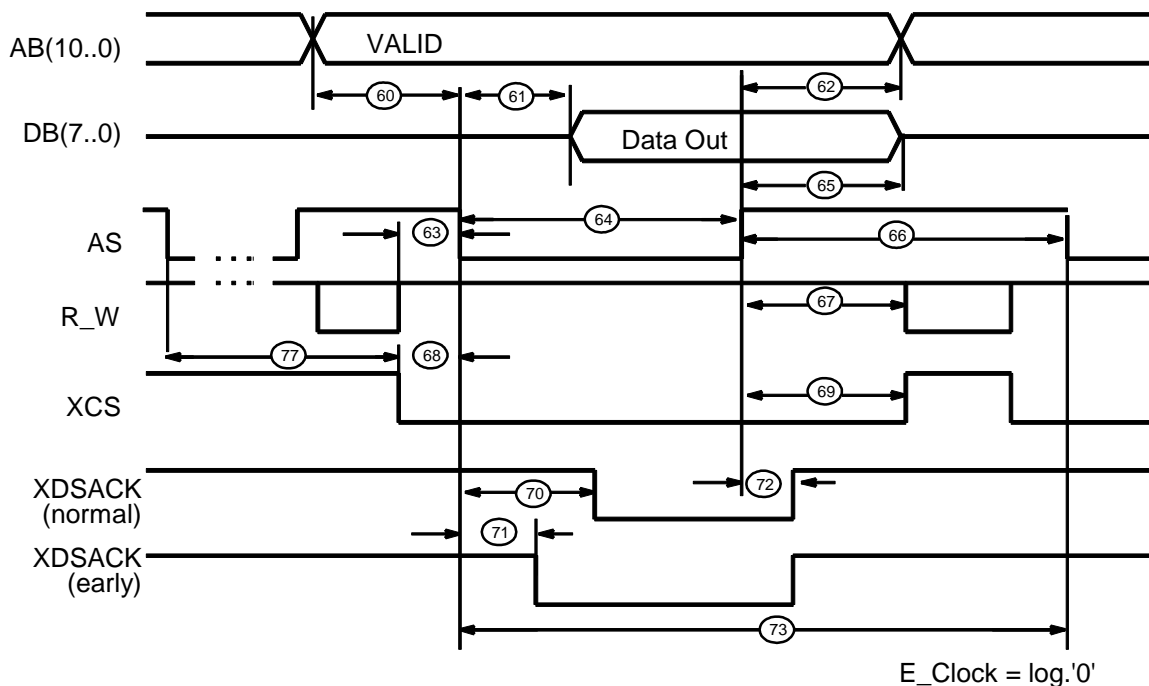

Asynchronous Motorola-Mode, Processor-Write-Timing

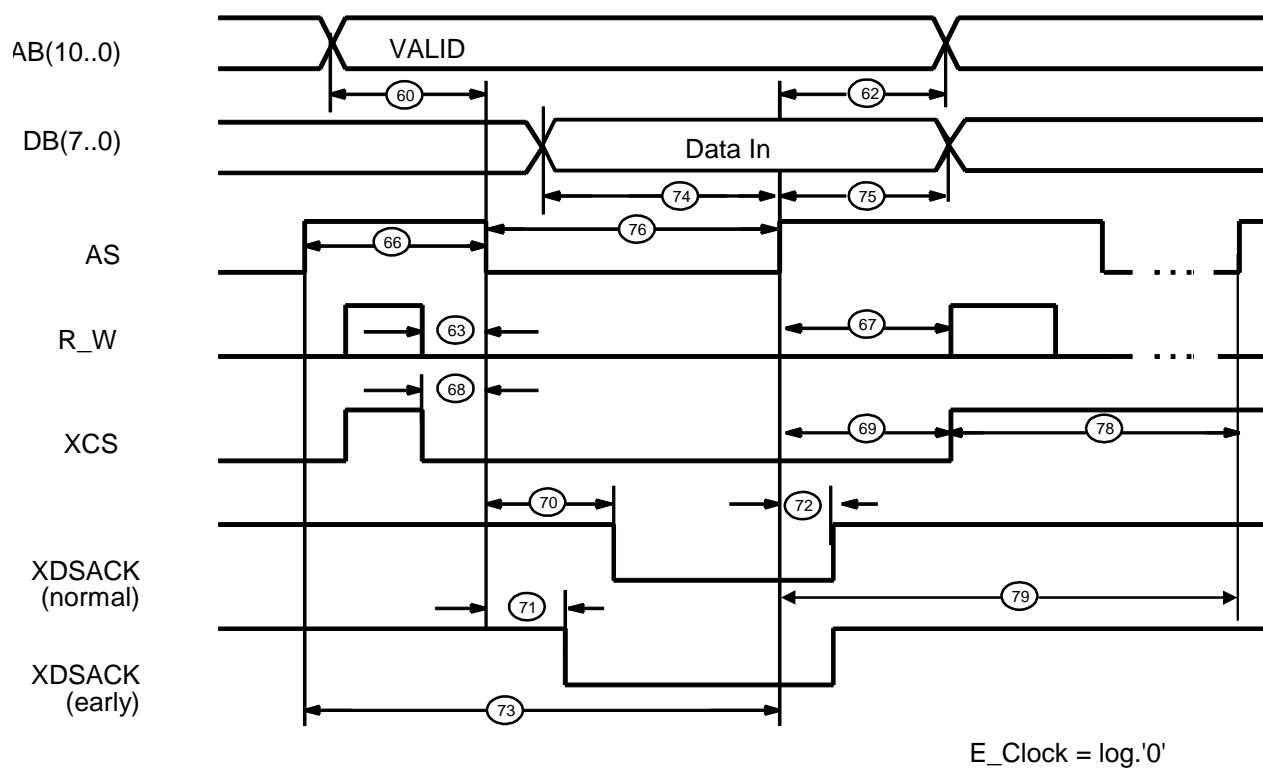

8.5.6 Serial Bus Interface

No.	Parameter	MIN	MAX	Unit
Pulse 48 MHz:				
1	RTS ↑ to TxD Setup Time	4T		
2	RTS ↓ to TxD Hold Token	4T		

T = Clock pulse cycle (48MHz)



8.5.7 Housing

PQFP-44 Housing

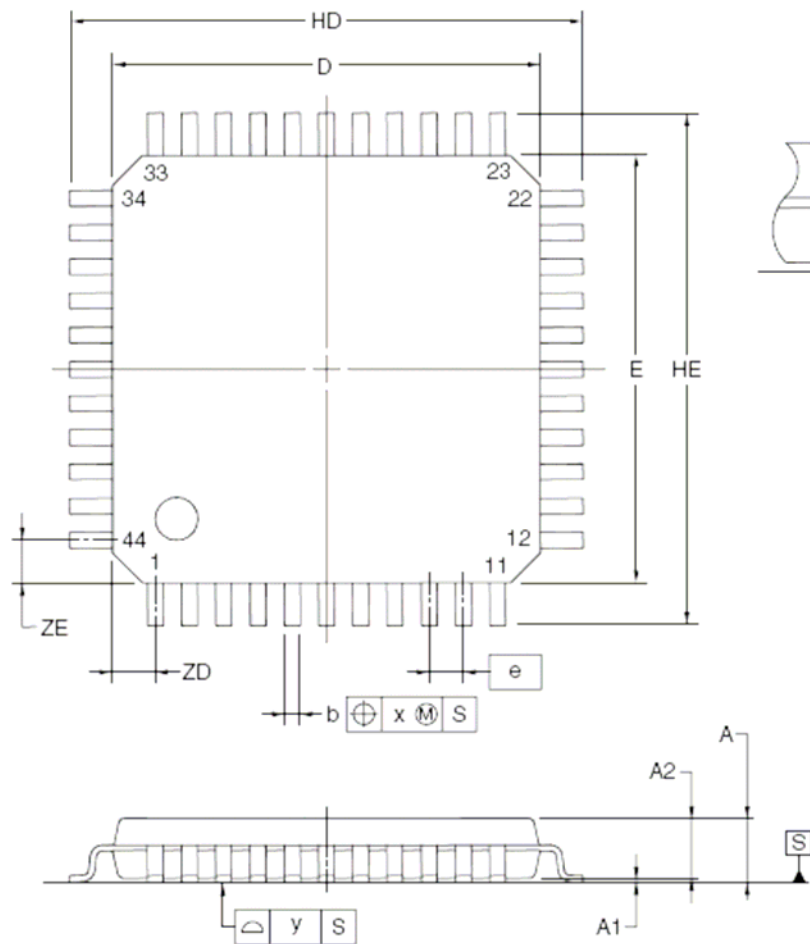

NOTE

Each lead centerline is located within 0.20 mm of its true position at maximum material condition.

(UNIT:mm)

ITEM	DIMENSIONS
D	10.00±0.20
E	10.00±0.20
HD	12.00±0.20
HE	12.00±0.20
A	1.60 MAX.
A1	0.10±0.05
A2	1.40±0.05
A3	0.25
b	0.37 ^{+0.08} _{-0.07}
c	0.145 ^{+0.055} _{-0.045}
L	0.50
Lp	0.60±0.15
L1	1.00±0.20
θ	3° ^{+5°} _{-3°}
e	0.80
x	0.20
y	0.10
ZD	1.00
ZE	1.00

P44GB-80-UES-1

Attention:
The footprint have changed between SPC3 and SPC3LV

8.5.8 Processing Instructions

ESD protective measures must be maintained for all electronic components.

SPC3 is a **cracking-endangered component** that must be handled as such.

A drying process must be carried out before SPC3 is processed. The component must be dried at **125° C for 24 hours** and then be processed **within 48 hours**. This drying process may be carried out once only because the component is soldered.

It must also be ensured that the SPC3's connections are not bent. Flawless processing can be guaranteed only if a planity of less than 0.1 mm is ensured. **SPC3** is released for infrared soldering with a soldering profile according to CECC00802.

9 PROFIBUS Interface

9.1 Pin Assignment

The data transmission is performed in RS 485 operating mode (i.e., physical RS 485).
The SPC3 is connected via the following signals to the galvanically isolated interface drivers.

Signal Name	Input/ Output	Function
RTS	Output	Request to send
TXD	Output	Sending data
RXD	Input	Receiving data

The PROFIBUS interface is a 9-way, sub D, plug connector with the following pin assignment.

Pin 1 - Free
Pin 2 - Free
Pin 3 - B line
Pin 4 - Request to send (RTS)
Pin 5 - Ground 5V (**M5**)
Pin 6 - Potential 5V (**floating P5**)
Pin 7 - Free
Pin 8 - A line
Pin 9 - Free

The cable shield must be connected to the plug connector housing.

The free pins are described as optional in EN 50170 Vol. 2. If used, they should conform to the specifications in DIN192453.

CAUTION:

The designations A and B of the lines on the plug connector refer to the designations in the RS 485 standard, and not the pin designation of driver ICs.
Keep the cable from driver to connector as short as possible.

Use of higher baud rates (i.e., 3 to 12 Mbaud) requires the use of new plug connectors. These connectors compensate for line interferences on all possible combinations of cables.

6ES7 972-0BB10-0XA0 with PG socket
6ES7 972-0BA10-0XA0 without PG socket

9.2 Example for the RS 485 Interface

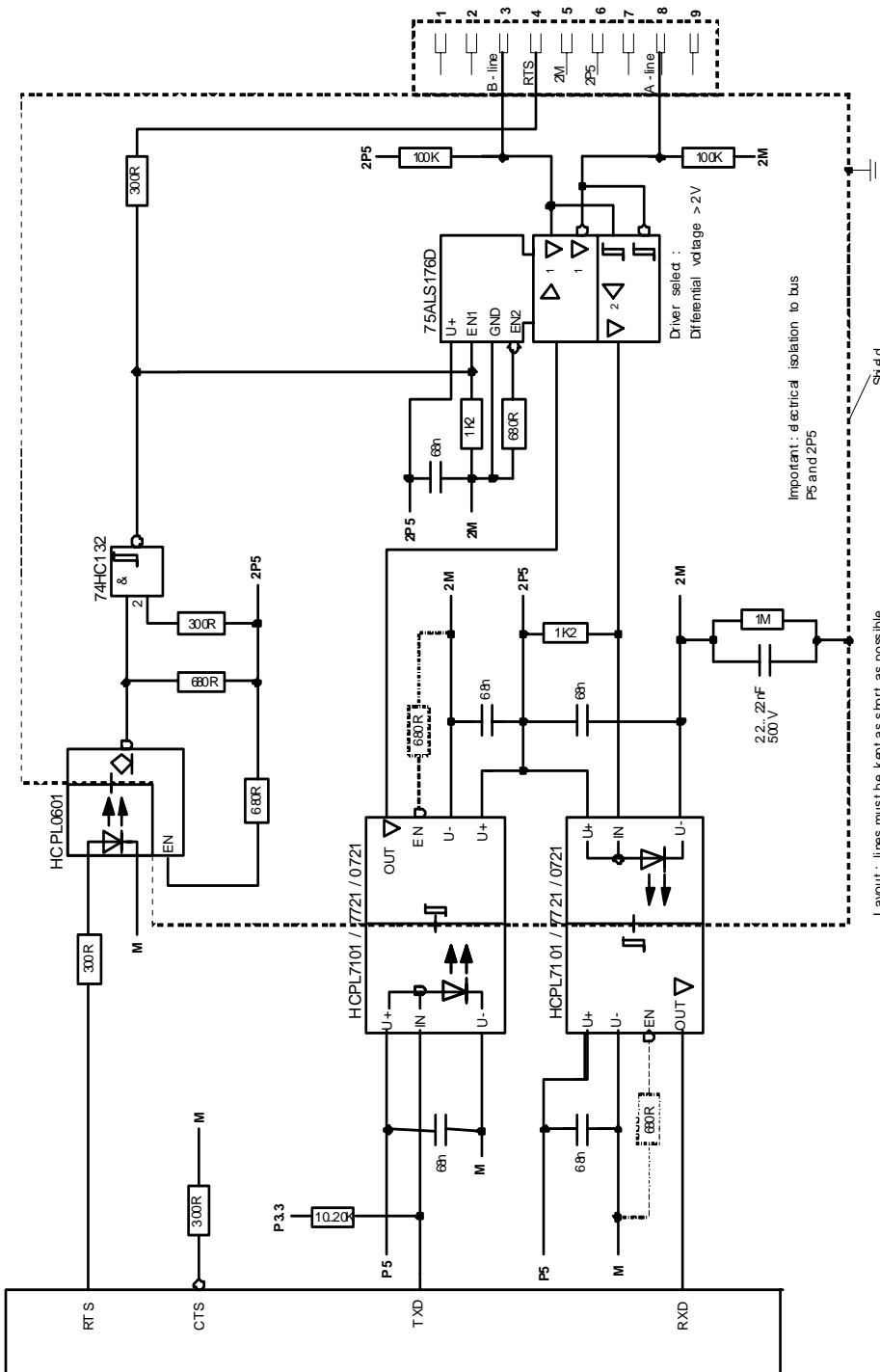

Explanations of the circuitry:

The bus driver input EN2 has to be connected to low potential to ensure that after transmission of a telegram the ASIC is able to listen to the transmitted data.

To minimize the capacity of the bus lines the user should avoid additional capacities. The typical capacity of a bus station should be 15 ... 25 pF.

10 Appendix

10.1 Addresses

PROFIBUS User Organisation

PNO
Office
Mr. Dr. Wenzel
Haid- und Neu- Straße 7
76131 Karlsruhe
Tel.: (0721) 9658-590

Technical contact person at ComDeC in Germany

Siemens AG
I IA SE RD73
Mr. Putschky

Address:
Postfach 2355
90713 Fürth

Tel.: (0911) 750 - 2078
Fax: (0911) 750 - 2100
email: Gerd.Putschky@siemens.com

Technical contact person at the PROFIBUS Interface Center in the United States

PROFIBUS Interface Center
One Internet Plaza
PO Box 4991
Johnson City, TN 37602-4991

Fax : (423) - 262 - 2103

Your Partner: Ron Mitchell
Tel.: (423) - 262 - 2687
email: Ron.Mitchell@sea.siemens.com

10.2 General Definition of Terms

ASPC2	Advanced Siemens PROFIBUS Controller, 2 nd generation
SPC2	Siemens PROFIBUS Controller, 2 nd generation
SPC3	Siemens PROFIBUS Controller, 3 rd generation
SPC3LV	Siemens PROFIBUS Controller, 3 rd generation Low Voltage
SPM2	Siemens PROFIBUS Multiplexer, 2 nd generation
LSPM2	Lean Siemens PROFIBUS Multiplexer, 2 nd generation
DP	Distributed I/Os
FMS	Fieldbus Message Specification
MS	MicroSequencer
SM	State Machine

10.3 Ordering of ASICs

For Ordering SPC3 ASICs please refer to your contact person in the Siemens local branch office and use one of the ordering numbers depending on the amount you want to order.

SPC3LV (NEC)

ASIC SPC3LV	6ES7 195-0BG00-0XA0	Evaluation pack; 5pcs
(STEP C)	6ES7 195-0BG10-0XA0	Single tray; 160pcs
Lead free	6ES7 195-0BG20-0XA0	Try box; 800pcs.
	6ES7 195-0BG30-0XA0	6 tray box; 4800pcs.
	6ES7 195-0BG40-0XA0	Tape and reel; 1000pcs.

11 Appendix A: Diagnostics Processing in PROFIBUS DP

11.1 Introduction

PROFIBUS DP offers a convenient and multi-layer possibility for processing diagnostics messages on the basis of error states.

As soon as a diagnostics request is required, the slave will respond in the current data exchange with a high priority reply message. In the next bus cycle, the master then requests a diagnostics from this slave, instead of executing normal data exchange.

Likewise, any master (not only the assigned master!) can request a diagnostics from the slave. The diagnostics information of the DP slave consists of standard diagnostics information (6 bytes), and can be supplemented by user-specific diagnostics information.

In the case of the ASICs, SPM2, and LSPM2, extensive diagnostics is possible through corresponding wiring. In the case of the intelligent SPCx solution, adapted and convenient diagnostics processing can be carried out through programming.

11.2 Diagnostics Bits and Expanded Diagnostics

Parts of the standard diagnostics information are permanently specified in the firmware and in the micro-program of the ASICs through the state machine.

Request diagnostics only once („update_diag(..)“) if an error is present or changes. By no means should diagnostics be requested cyclically in the data exchange state; otherwise, the system will be burdened by redundant data.

Three information bits can be influenced by the application:

11.2.1 STAT_DIAG

Because of a state in the application, the slave can't make valid data available. Consequently, the master only requests diagnostics information until this bit is removed again. The PROFIBUS DP state is, however, Data_Exchange, so that immediately after the cancellation of the static diagnostics, data exchange can start.

Example: failure of supply voltage for the output drivers

11.2.2 EXT_DIAG

If this bit is set, a diagnostics entry **must** be present in the user-specific diagnostics area. If this bit is not set, a status message can be present in the user-specific diagnostics area.

User-Specific Diagnostics

The user-specific diagnostics can be filed in three different formats:

Device-Specific Diagnostics:

The diagnostics information can be coded as required.

	Bit 7	Bit 6	Bit 5-0
Header Byte	0	0	Block length in bytes, including header
Diagnostics Field	Coding of diagnostics is device-specific		
.....	Can be specified as required		

Identifier-Related Diagnostics:

For each identifier byte assigned during configuration (for example, 0 x 10 for 1 byte input), a bit is reserved.

In the case of a modular system with an identifier byte each per module, module-specific diagnostics can be indicated. One bit respectively will then indicate diagnostics per module.

	Bit 7	Bit 6	Bit 5-0
Header Byte	0	1	Block length in bytes including header
Bit Structure	1		1

↑ Identifier Byte 7 has
diagnostics

etc.

↑ Identifier Byte 0 has
diagnostics

Channel-Related Diagnostics:

In this block, the diagnosed channels and the diagnostics cause are entered in sequence. Three bits are required per entry.

	Bit 7	Bit 6	Bit 5	Bit 4 - 0
Header Byte	1	0	Identification Number	
Channel Number	Coding Input/Output		Channel Number	
Type of Diagnostics	Coding Channel Type		Coding Error Type	

Coding of the error type is in part manufacturer-specific; other codings are specified in the Standard.

Example:

0	0	0	0	0	1	0	0	Device -related diagnostics.
Device-specific diagnostics field of length 3								Meaning of the bits is specified manufacturer-specific.
0	1	0	0	0	1	0	1	Identifier -related diagnostics.
							1	Identification number 0 has diagnostics.
			1					Identification number 18 has diagnostics.
1	0	0	0	0	0	0	0	Channel -related diagnostics, identification number 0.
0	0	0	0	0	0	1	0	Channel 2.
0	0	0	1	0	1	0	0	Overload, channel organized bit by bit.
1	0	0	0	1	1	0	0	Channel -related diagnostics identification number 12.
0	0	0	0	0	1	1	0	Channel 6.
1	0	1	0	0	1	1	1	Upper limit value exceeded, channel organized word by word.

Status

If the Bit EXT_DIAG is set to 0 , data is viewed as status info from the system view. f.e. cancellation of the error triggering the diagnostics.

11.2.3 EXT_DIAG_OVERFLOW

This bit is set if more diagnostics data is present than will fit in the available diagnostics data area. For example, more channel diagnostics could be present than the send buffer or the receive buffer makes possible.

11.3 Diagnostics Processing from the System View

Inasmuch as it is bus-specific, the diagnostics information of the slaves is managed solely by the master interface (for example, IM308B).

All diagnostics from the application are made available to the S6 program via corresponding data bytes. If the **External Diagnostics bit** is set, the slaves to be diagnosed can already be evaluated in the diagnostics overview. Then, a special error routine can be called up, whereby the standard diagnostics information and the user-specific information can be evaluated.

After eliminating the current diagnostics situation, this can be signalled as a status message from the slave **without setting the external diagnostics bit**.

With the COM ET200, a comfortable diagnostics tool is available on-line. At the present time, identification-related diagnostics information can be displayed with it in plain text. In later phases, channel-related diagnostics will also be supported. User-specific diagnostics are only displayed if the EXT_DIAG bit is set.

The figure below shows a screen during data processing, for example:

Set Program File	C:PNO4..ET.200	SIMATIC S5 / COM ET 200
SINGLE DIAGNOSTICS		
Station Number: 30		Station Type: ET 200U-COMBI
Station Designation:	Station4	
Station Status:	Slave not ready for data exchange External diagnostics Configuration error	
Device-Related Diagnostics		
	KH = 01	
Identification-Related Diagnostics		
	Slot	
Active	3	
F1	F2	F3
F4	F5	F6
F7	F8	EXIT

In the type file for the COM ET200 and in the GSD [device master data] file, fields are already provided for referencing device-specific bits and pertinent plain text messages (for example, Bit 7: „I have had it; good night!“).

12 Appendix B: Useful Information

12.1 Data format in the Siemens PLC SIMATIC

The SPC3 always sends data from the beginning of the buffer till the end. 16Bit values are shown in the Motorola format. For example:

