

These operating instructions apply to:

**Series NVG
Series NVR
Series NVT**



Important note:

Before use of the pneumatic linear vibrators series NVG, NVR and NVT read this operating instruction carefully and store afterwards.

Netter GmbH does not assume liability for damage to property and persons if the product has been technically modified or if the notes and regulations of these operating instructions have not been observed.

This documentation is copyrighted. All rights, e.g. for translation into other languages, reprinting and copying of these operating instructions or parts hereof remain strictly reserved.

Table of Contents

1	GENERAL NOTES	3
2	TECHNICAL DATA	4
3	DESIGN AND FUNCTION	6
4	SAFETY	7
5	TRANSPORT AND STORAGE	8
6	INSTALLATION	9
7	START-UP / OPERATION	12
8	SERVICE / MAINTENANCE	13
9	TROUBLESHOOTING	14
10	SPARE PARTS	15
11	APPENDIX	16
11.1	Accessories	16
11.2	Disposal	16
11.3	Enclosures	16

Scope of delivery:



Check the packaging for possible signs of transport damage. In the event of damage to the packaging, check that the contents are complete and undamaged. If there is any damage, inform the shipping agent. Compare the scope of the delivery with the delivery note.

1 General notes

Pneumatic external vibrators of series NVG, NVR and NVT comply with the EC-machine regulation 2006/42/EG. In particular, standards DIN EN ISO 12100 part 1 and 2 have been observed.

The vibrators generate non directed vibrations.

General areas of application are: Loosening, conveying, sorting, compacting, and separating of bulk materials and reduction of friction.

NVG, NVR and NVT - vibrators are used for the compaction of concrete, to empty bunkers, to drive conveyor troughs, sieves and vibrating tables.





The drive medium is clean (filtered) compressed air or nitrogen.

In addition, the frequency can be infinitely controlled by means of pressure regulators or throttles in the supply line.

Special Features:

- No bearings
- Frequency infinitely variable by air pressure
- Easily and quickly removable
- Noise reduced design NQT

In these operating instructions the following information and danger symbols are used.

	Notes on important processes		Warning of a danger source
	Important note on processes to be especially observed		Environmental waste disposal
	Ear protectors are required		

2 Technical data



Drive medium:

Clean (filter $\leq 50 \mu\text{m}$) compressed and lubricated air or nitrogen
Unfiltered air will cause damage to the vibrators.

Operating pressure:

2 bar to 6 bar*

Operating pressures must not be exceeded or fallen short of.

Temperature:

-10°C to 60°C*

Operating temperatures must not be exceeded or fall short of.
 For higher temperatures appropriate vanes are available.

Frequency:

Max. 15.000 min^{-1}

The maximum speed must not be exceeded.*

*) Higher temperatures and frequencies are only permitted after consultation by application engineers of Netter GmbH.

Type		NVR ^① , NVG ^②			NVT ^① , NVG ^②	
		49	55	61	82	113
Nominal frequency	[min^{-1}]	17.000	16.500	16.000	9.000	8.500
Centrifugal force	[N]	7.130	11.000	14.250	15.320	38.830
Unbalance	[cmkg]	0,45	0,74	1,02	3,45	9,80
Air consumption	[l/min]	1.000	1.100	1.200	1.600	1.700
Weight without hose	[kg] ①	6,6	7,0	7,6	14,9	16,9
	[kg] ②	7,1	7,3	7,8	19,7	22,6

Type		NVT ^① , NVG ^②			NQT	
		84	87	105	93	108
Nominal frequency	[min^{-1}]	16.000	15.200	14.500	10.000	10.000
Centrifugal force	[N]	27.400	37.500	62.260	18.480	24.788
Unbalance	[cmkg]	1,95	2,96	5,40	3,37	4,52
Air consumption	[l/min]	1.600	1600	1.800	1.450	1.550
Weight without hose	[kg] ①	14,0	14,4	16,3	-	-
	[kg] ②	20,0	20,4	22,4	-	-
Weight with hose	[kg]	-	-	-	18,6	20,3

NVG with base plate. NVT and NQT with carrier handle on top, for bracket NVH 4. NVR without carrier handle, for bracket NVH 1.
 Data obtained on 6 bar



Sound level:

During the operation the sound level of the vibrators exceeds 85 dB(A), ear protectors are required.

Due to their high power, the external vibrators NVG, NVT and NVR have a sound level higher than 85 dB (A), especially if they are mounted on plates, molds, etc.

A sound insulation of the unit is only useful if plates and formwork panels are also insulated.

Pressure reduction reduces the sound level, but also the power.



Operating time:

The technical performance changes with long operating times (wear).

Dimensions [mm]

Vibrators:

NVR / NVT / NQT

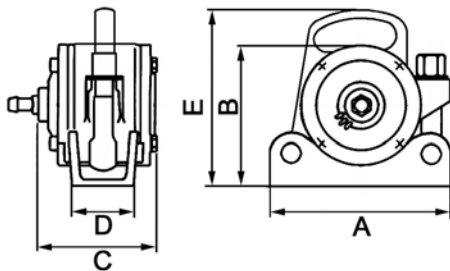

NVG

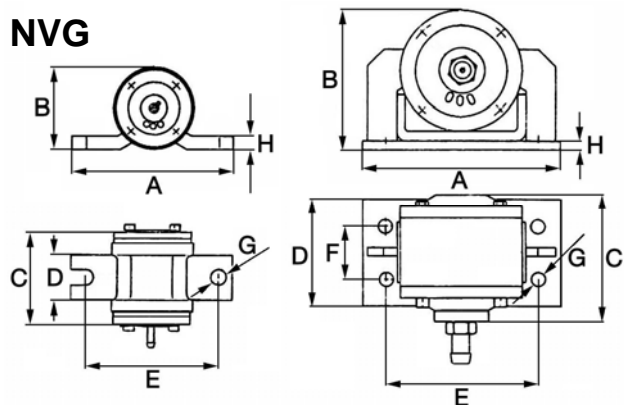

Type	A	B	C	D	E	F	Ø G	H
NVG 49, 55, 61	220	111	175	60	180	-	20	20
NVR 49, 55, 61	182	140	175	90	-	-	-	-
NVT 82, 113, 84, 87, 105	240	185	150	83	225	-	-	-
NVG 82, 113, 84, 87, 105	260	187	145	140	200	70	17	12
NQT 93, 108	240	230	240	80	-	-	-	-

Bracket:

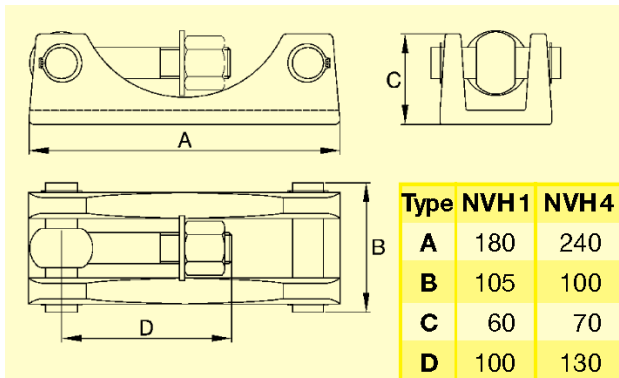

Type	NVH1	NVH4
A	180	240
B	105	100
C	60	70
D	100	130

3 Design and function

The vibration is produced by the eccentric to the shaft driven internal rotor, and (for larger units) by the external rotor.

The compressed air enters at **P** into the shaft and pushes the movable vane against the inner rotor.

Through the air channels of the vane the compressed air moves to the pressure side (air chamber **F**) of the vane.

The constant air increases the volume of the air chamber **F** and displaces the position of the rotor.

The rotation of the inner rotor changes the shape of the chamber **F** to finally connect the air with chamber **G** and the compressed air escapes through the exhaust holes **R**.

The rotor turns now with the help of the kinetic energy until it reaches the starting position and the two air chambers, **F** and **G** are again incurred. For larger units an additional external rotor is driven by the inner rotor.

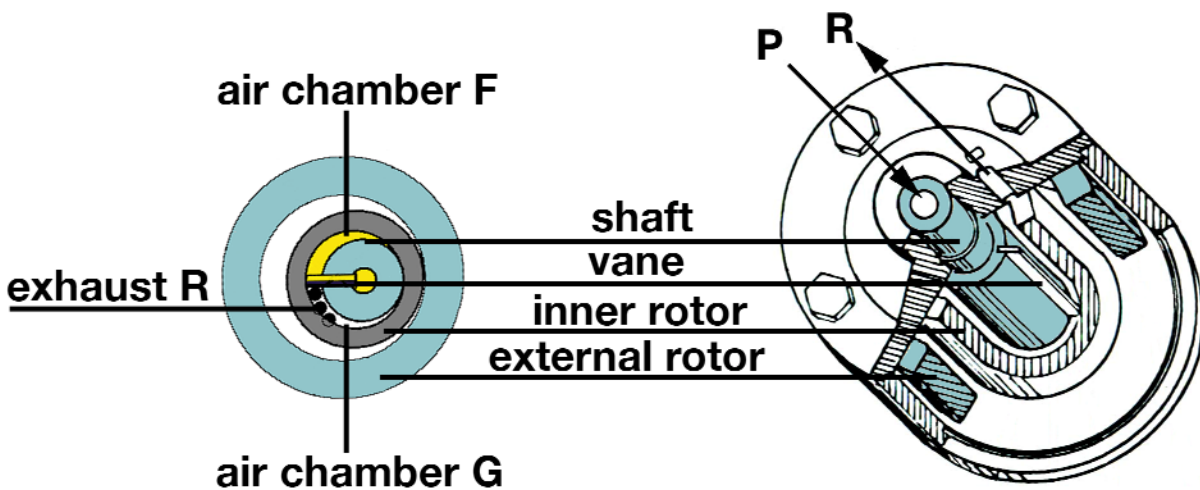

The position of the exhaust holes is observed during installation.



In this position, the vibrator starts properly, the vane is free. The exhaust air holes are in position below right.

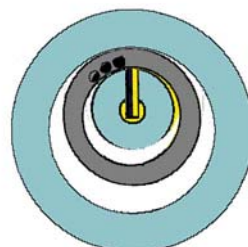

In this position, the vibrator do not start, the inner rotor is lying on the vane. The exhaust air holes are in position above left.

4 Safety



NVG, NVR and NVT vibrators work with compressed air. Make sure the compressed air supply is switched off during installation. Disconnect the supply lines (quick coupling) before starting other work on vibrators and supply lines. Before starting operation all hoses must be tightly connected. A pressurized hose coming loose can cause severe injury.

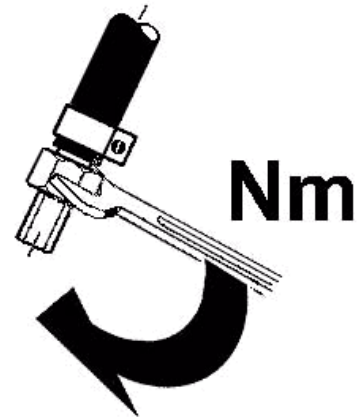

Vibrators as well as parts of the structure may come loose because of vibration. Falling parts can cause damage to persons and material. Screw retention components and/or Loctite or similar must be used. Screw connections must be checked and, if necessary, retightened after 1 hour of operation and then at regular intervals (normally each month). In critical installation situations, the unit must be secured with a steel rope.

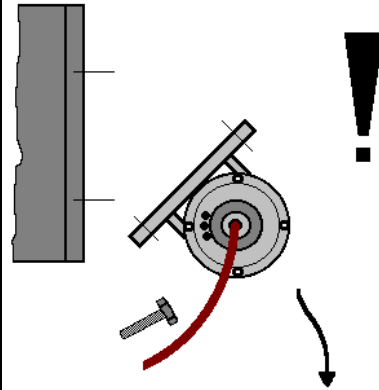

Sound level:

During the operation the sound level of the vibrators exceeds 85 dB(A), ear protectors are required. Due to their high power, the external vibrators NVG, NVT and NVR have a sound level higher than 85 dB (A), especially if they are mounted on plates, molds, etc. A sound insulation of the unit is only useful if plates and formwork panels are also insulated. Pressure reduction reduces the sound level, but also the power.





Technical changes to the equipment may affect the characteristics of the vibrators or even damage the units and cause the rejection of any warranty claims.
Failures to comply with the operating instructions cause the rejection of any warranty claims.

Drive medium:

Clean (filter $\leq 50 \mu\text{m}$) compressed and lubricated air or nitrogen
Unfiltered air will cause damage to the vibrators.

Operating pressure:

2 bar to 6 bar*
 Operating pressures must not be exceeded or fallen short of.



Temperature:

-10°C to 60°C*
 Operating temperatures must not be exceeded or fall short of.
 For higher temperatures appropriate vanes are available.

Frequency:

Max. 15.000 min⁻¹
The maximum speed must not be exceeded.*

*) Higher temperatures and frequencies are only permitted after consultation by application engineers of Netter GmbH.

5 Transport and storage



Check the packing for possible shipping damage.
 If the packing is damaged, check the contents for completeness and possible damage. In case of damage inform the transport agent. Compare the scope of supply with the delivery note.

The units are packed ready for installation. The type plate is mounted on the vibrator.

The units are delivered with a socket, if the socket is not already part of the shaft.

If the units are ordered with 1 m hose, coupling and cock valve, this standard equipment is supplied ready assembled, if not specified differently.

Special transport conditions are not specified.

The units should be stored in a dry and clean environment.

Units must be oiled before being returned to the stores (put machine oil in air inlet and outlet and operate the vibrator short).



The storage temperature may be between -40°C and +60 °C.
 (This does not apply for operating temperature, compare with **chapter 4 SAFETY, "Permissible Operating Conditions"**).

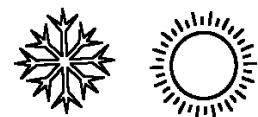

6 Installation



During installation please comply strictly with the safety regulations in chapter 4 and the accident prevention instructions! Make sure the compressed air supply is switched off during installation or when working on vibrator and air supply lines.

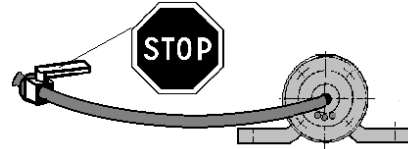

Mounting the vibrator:

The vibrators of series NVG are screwed with the base plate to the vibrating mass. Depending on the housing size the NVG is available with a base plate with 2 bores ($\varnothing 16,5$ mm) or 4 bores ($\varnothing 17,0$ mm). These base plates are fastened accordingly with 2 or 4 screws M16, quality 8.8.

The vibrators of the series NVR or NVT are to be fastened to the vibrating mass by means of a separate bracket (NVH-1 or NVH-4).

These brackets must be welded to the construction to be vibrated.



In critical installation situations the unit must be secured with clamp and steel rope.

Installation examples for NVG and NVT:

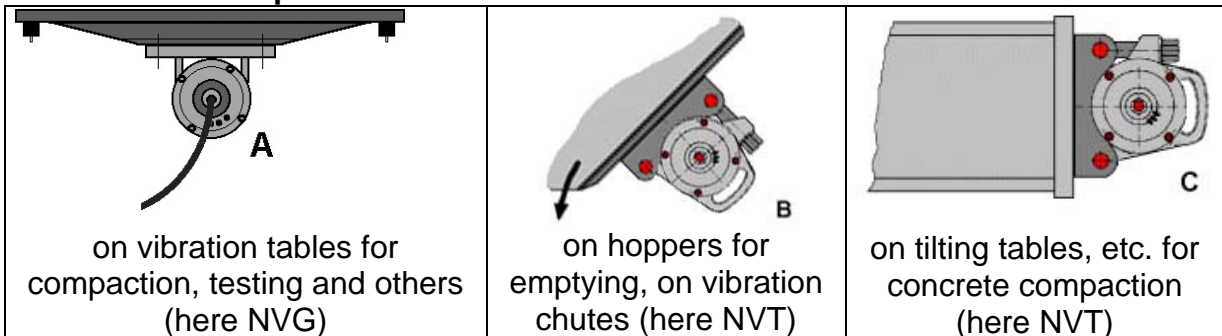

The shape of the housing has only a minor influence on the effect. With the units NVT, which are clamped with a spigot nut in the welded on bracket

Start

The vibrators have to be mounted with the air holes in positions **A** or **B**.

In positions **C** or **D** the vibrator will not start, because the rotor is resting on the vane, which is described in "Design and Function," shown in the lower figure. If required, the cover must be rotated. This procedure is described under "exchange of the vane".

NVH-1 or NVH-4, the vibration transmission is due to the particularly strong connection especially favorable.

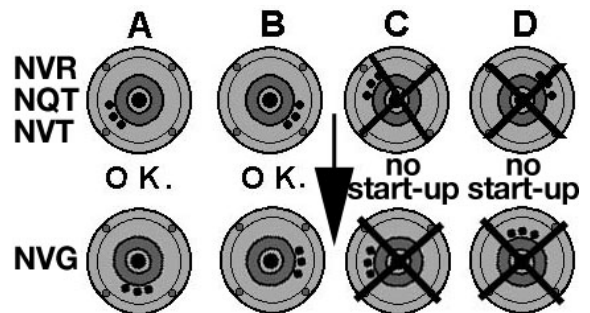

Best start-up in Pos. A + B

No start-up in Pos. C + D

Mounting notes

The types NVG have a base plate which is bolted to the vibrating structure.

The types NVR and NVT have a cast housing which is clamped in a bracket NVH -1 or NVH-4 by a spigot nut.

This brackets in weldable cast steel get to be welded to the vibrating structure.

This combination vibrator / construction is particularly force-fit.

Vibrators with the housing design NVR and NVT are quickly removable.

Then for each position a bracket is required.

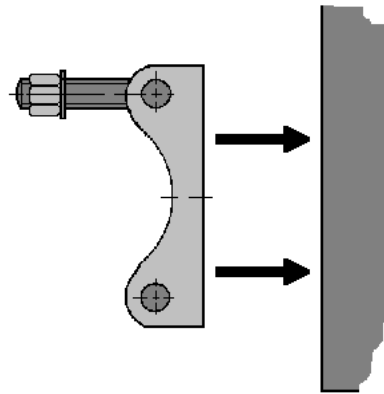

Bracket NVH-1 or NVH or 4
for NVR or NVT



As a protection against loosening use self-locking screws and nuts, self-locking lock washers (no spring washer) or use a liquid screw retention agent, e.g. Loctite 270.



The tightening torques can be taken from the following table. Higher tightening torques may cause fracture of screws or tearing of threads.

Inadequate screw connections may cause loosening of units by vibration. This can cause damage to persons and material!



Recommended average tightening torques for screws property class 8.8 used on NVG-vibrators (screws as delivered, not additionally greased or oiled):

Type	Thread*	Tightening torque
All types NVG	M 16	215 Nm
Housing screws	M 8	25 Nm
	M 10	51 Nm



The screws M16 for NVG (version with base plate) can be secured with LOCTITE or similar.

Tighten the spigot nut of the bracket NVH-1 with 150 Nm, tighten the spigot nut of the bracket NVH-4 with 300 Nm and check periodically, see Chap. 9 "Troubleshooting (Power drop)".

Air supply line:

The air resistance increases with the hose length. The following recommendations refer to hose lengths of max. 5 m up to the next bigger hose cross section (up to NVG/NVR 61 a length of 10 m is possible). For longer supply lines we recommend bigger cross sections.

If the vibrators are supplied with a 1 m hose, coupling and control cock valve, the specification "5 m" (or 10 m) to the supplied coupling is valid.

Minimum cross-sections for valves and hoses:

Valve: Connection G1/2, NW 12

Hoses: Inner diameter 16 mm



Check whether all hoses, valves and fittings are approved for the operating pressure. When being used under higher temperatures, the permissible pressure may be lower. Before applying any pressure check that all pressure connections are secure (hose clamps tightened?).



When using compressed air as drive medium, it must be clean (filtered). Unfiltered air leads to excessive wear and complete damage of the vibrator. The compressed air supply must be reliably fastened.

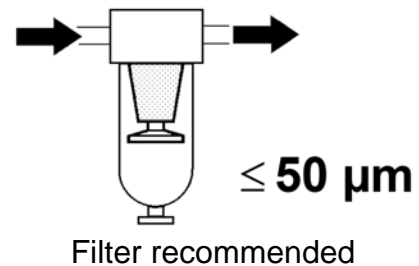

Checklist for installation:

- 1) Install the unit. Lock the fastening screws.
- 2) Attend the expected operating temperature
- 3) Assemble maintenance unit, valve, supply line.
Have fastening screws been locked? Check!
- 4) Specification on hose length and diameter observed
- 5) Has the unit been secured against falling down?

7 Start-up / Operation

Start-up of the vibrators can be performed immediately after the correct installation.

The frequency can be adjusted or regulated with the pressure regulator on the service unit.



Sound level:

During the operation the sound level of the vibrators exceeds 85 dB(A), ear protectors are required.

Due to their high power, the external vibrators NVG, NVT and NVR have a sound level higher than 85 dB (A), especially if they are mounted on plates, molds, etc.

A sound insulation of the unit is only useful if plates and formwork panels are also insulated.

Pressure reduction reduces the sound level, but also the power.

Standard installation

Special plans on request

If the supply line is fitted with a 2/2-way cock valve, this can be used to regulate the frequency and the centrifugal force. A pressure regulator allows a more exact regulation (independent from the original pressure). Valve, filter and lubricator (regulator) may also be used for several units. The size of these components must then be determined accordingly.

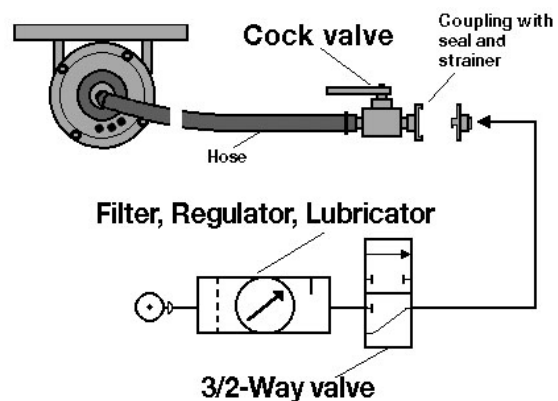

Start-up

The vibrators have to be mounted with the air holes in position **A** or **B**.

In position **C** or **D** the vibrator will not start, because the rotor is resting on the vane, which is shown in "Design and Function," in the lower figure.

If necessary, the housing must be rotated. If this is not possible (e.g. in case of NVT housings in conjunction with the bracket NVH), the cover can be rotated. This procedure is described under "Exchange of the vane", see page 15.

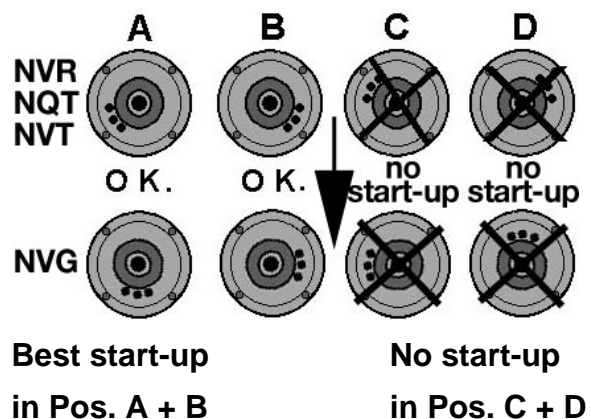



The use of lubricated air significantly increases the lifetime. If not lubricated compressed air is used, give periodically (e.g. every 1-2 hours) 1 cm³ oil in the supply line. Longer intervals are possible, but can cause rapid wear.
Recommended oil quality: SAE 10

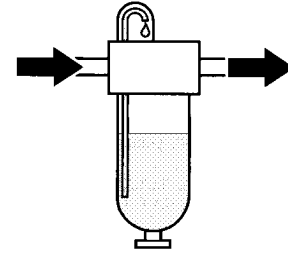

Oil quality SAE 10
2 - 3 drops/min



ATTENTION:
Adjust number of drops while unit is running.
Only after the adjustment and correct function of the mist lubricator the unit is ready for operation.

Checklist for commissioning:

- 1) Check all hose connections before opening the compressed air supply.
- 2) Ensure the use of ear protection.
- 3) Adjust the desired frequency on the pressure regulator.
- 4) Adjust the mist lubricator, if existing.



The fastening screws for vibrator and vibrating mass must be retightened or checked after 1 operating hour.

8 Service / Maintenance



When servicing the unit please observe the safety regulations in chapter 4.



Retightening:
Screw connections must be checked and, if necessary, retightened after 1 hour of operation (after initial start-up) and then at regular intervals (normally each month). The specified torque must thereby be observed (see chapter 6).



Before each inspection and service works shut off the compressed air supply and secure it against unintended activation!

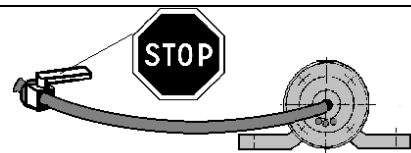

Mist lubricator:

With a mist lubricator connected in series make sure that it works as specified (contents diminishing? number of drops/min?). Top up oil.

Cleaning:

All NVT vibrators can be externally cleaned with pressure water, as long as the exhaust openings are closed.

Water must not enter into the inside.

Contamination:

Further notes can be found in chapter 9 „Troubleshooting“. The maintenance intervals mainly depend on the purity of the drive medium.

9 Troubleshooting

Fault	Possible cause	Remedy
No start	Air supply	Check the pressure at the unit! Sufficient pressure? Check the valve.
	Wrong position of exhaust bores, see "Installation"	Turn vibrator or cover, see below "Exchange of vane".
	Vane jammed, missing or incorrectly inserted.	Check the vane, see below "Exchange of vane".
Too low power	Hose cross-sections	Observe minimum cross-sections and lengths, see specifications under "Installation". Check the air pressure. Check the supply lines.
	Wear	Check the vane in particular, also cover and inner rotor.
	Unit runs in resonance frequency. No increase in speed despite an increase of pressure.	Better reinforcement. Or choose a unit with a lower working moment (smaller outer rotor).
Power drop	Screws loose (typical: sudden speed reduction)	Re-tighten the screws, especially the nuts on NVH-brackets.
	Unit soiled	Fill approx. 1 cm ³ of kerosene into the supply line and run the vibrator for a moment.
Sound level	Frequency range, rattling	Avoid locations which may rattle. Adjust the frequency to a lower sound pressure level.

Exchange of the Vane

The vane is an item which wears out. The use of clean and lubricated compressed air prolongs its lifetime.

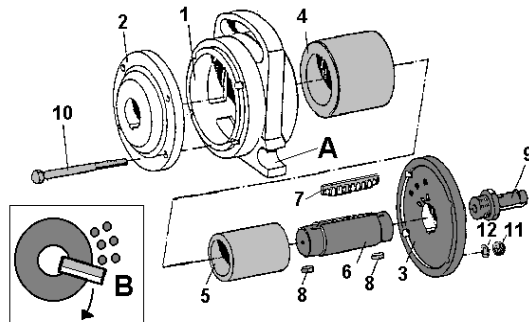

In case of a power drop the reason is normally a worn vane - if the above tests do not reveal anything else. The vane must be replaced as follows:

- 1 Housing
- 2 Front flange
- 3 Rear flange
- 4 Outer rotor
- 5 Inner rotor
- 6 Shaft
- 7 Vane
- 8 Fitting key
- 9 Connecting fitting
- 10 Housing screw
- 11 Stop nut
- 12 Lock washer

Loosen the housing screws **10**, **11**, **12** and press the axle **6** out from the side of the front flange **2**. This may be accomplished either hydraulically (raise the rim of the housing for this purpose) or by clamping the recess **A** of the housing in a vice and knocking the shaft **6** with a hammer and a brass mandrel. The shaft will then drop out of the housing together with the rear flange **3** and the fitting **9**. These parts remain together. The rotor or the rotors **4**, **5** will also fall out.

Now inspect the vane for signs of wear and replace it with a new one, if this is necessary. The vane must be easy to move, or otherwise it must be

ground in so that it fits tightly. The open channels of the vane must point away from the exhaust bores **B**.

Assembly must be performed in reverse order, whereby the cover is pressed in or knocked in with a plastic hammer. During this procedure observe the correct position of the flanges to each other (fitting keys **8**!). If necessary (start-up position) the flanges may be turned. In this case the front flange **2** must also be loosened. The housing screws **10** must all be re-tightened after a short test operation.

Tightening torque for housing screws:	M 8 = 25 Nm	M 10 = 51 Nm
---------------------------------------	-------------	--------------

10 Spare Parts

Please provide the following information when ordering spare parts:

1. Type of unit
2. Description of spare part
3. Required quantity

11 Appendix

11.1 Accessories

The following accessories are available for the vibrators (on request):

Description	Remark
Hose material and fittings	for air supply and exhaust (option), in different qualities and dimensions
3/2- or 2/2-way valves	for electric, pneumatic and manual control
Throttle valves	for frequency control, manually adjustable or pneumatically controllable (for remote control). See also F-L-R units (pressure regulators).
F-L-R units	Filter, pressure regulator, lubricator or complete units respectively.
Duty and break cycle control	electric or pneumatic, for interval operation
Brackets	for quick relocation of vibrators on formwork, containers etc.
Special versions:	With exhaust air discharge, e.g. for the use in aggressive environments, rotors for other working moments.

11.2 Disposal

Depending on the material, the parts must be disposed of according to official regulations.

Material specifications:

All parts of these vibrators are suitable for recycling

- Housing: ⇒ steel or cast steel
- Rotor, Shaft, Cover: ⇒ hardened steel
- Bracket NVH: ⇒ weldable cast steel or steel



All units can be disposed of through Netter GmbH.
The current disposal prices are available on request.

11.3 Enclosures

Enclosure(s):

Declaration of incorporation



Further information available on request: Leaflet no. 14 (Vibrators),