

These operating instructions apply for:

VAC 8	VAC 15
VAC 10	VAC 20
VAC 11	VAC 30
VAC 12	VAC 40



### Important note:

Before use of the pneumatic linear vacuum-fixing-devices series VAC read this operating instruction carefully and store afterwards.

Netter GmbH does not assume liability for damage to property and persons if the product has been technically modified or if the notes and regulations of these operating instructions have not been observed.

This documentation is copyrighted. All rights, e.g. for translation into other languages, reprinting and copying of these operating instructions or parts hereof remain strictly reserved.

## Table of Contents

<b>1</b>	<b>GENERAL NOTES</b>	<b>3</b>
<b>2</b>	<b>TECHNICAL DATA</b>	<b>4</b>
<b>3</b>	<b>DESIGN AND FUNCTION</b>	<b>8</b>
<b>4</b>	<b>SAFETY</b>	<b>9</b>
<b>5</b>	<b>TRANSPORT AND STORAGE</b>	<b>11</b>
<b>6</b>	<b>INSTALLATION</b>	<b>12</b>
<b>6.1</b>	<b>Connection of power supply</b>	<b>12</b>
<b>6.2</b>	<b>Mounting of vibrator and hose set</b>	<b>13</b>
6.2.1	VAC 8, VAC 10, VAC 11 and VAC 12	14
6.2.2	VAC 15, VAC 20 and VAC 30	15
6.2.3	VAC 40	16
<b>7</b>	<b>START-UP / OPERATION</b>	<b>17</b>
<b>8</b>	<b>SERVICE, MAINTENANCE</b>	<b>18</b>
<b>9</b>	<b>TROUBLESHOOTING</b>	<b>19</b>
<b>10</b>	<b>SPARE PARTS</b>	<b>20</b>
<b>11</b>	<b>APPENDIX</b>	<b>20</b>
<b>11.1</b>	<b>Accessories</b>	<b>20</b>
<b>11.2</b>	<b>Waste disposal</b>	<b>20</b>
<b>11.3</b>	<b>Enclosures</b>	<b>20</b>

### Scope of delivery:



Check the packing for possible shipping damage.  
If the packing is damaged check the contents for completeness and possible damage. In case of damage inform the transport agent.  
Compare the scope of supply with the delivery note.

## 1 General notes

Netter vacuum fixing devices of series VAC for pneumatic vibrators are in strict compliance with the EC Machine Directive 2006/42/EC. The standard DIN EN 12100 has been observed in particular.

Vacuum fixing devices of series VAC are used for quick fastening of vibrators to smooth and, to a limited extent, also to rough and curved surfaces.

They are used in combination with vibrators for the emptying of transport containers or drums, for the cleaning of pipes etc.

Vacuum fixing devices are used where conventional fastening methods





for vibrators fail, frequent relocation of vibrators is required and welding or bolting is not possible.

The drive medium is compressed air or nitrogen.

Applications in the food industry and in wet areas are possible under strict compliance with the corresponding operating instructions of the operating company and if the attached vibrator is also suitable for such applications.

These vacuum fixing devices can also be used outdoors, but not in or under water or any other fluids.

In these operating instructions the following information and danger symbols are used.

	Notes on important processes		Warning of a danger source
	Important note on processes to be especially observed		Environmental waste disposal

## 2 Technical data



### Drive medium:

Clean ( $\leq 5 \mu\text{m}$  filter) compressed air or nitrogen

**Unfiltered air will cause damage to the mounted vibrators.**

### Operating pressure:

4 bar to 6 bar\*

Operating pressures must not be exceeded or fall short of

### Temperature:

-10°C to 60°C\*

Operating temperatures must not be exceeded or fall short of.

### Lubrication:

VAC fixing devices do not require lubrication.

For the mounted vibrator lubricated compressed air may be specified.

Please refer to the corresponding operating instructions for the vibrator.

\*) Higher operating pressures and temperatures are only permitted after consultation and written confirmation by application engineers of Netter GmbH.

Type	Generated vacuum [bar]		Generated suction power* [N]		Weight [kg]
	4 bar	6 bar	4 bar	6 bar	
VAC 8 + HG 10 N	0,60	0,85	340	481	0,95
VAC 8 + HG 10 S	0,60	0,85	340	481	1,20
VAC 10 + HG 10 N	0,60	0,85	465	658	1,05
VAC 10 + HG 10 S	0,60	0,85	465	658	1,30
VAC 11 + HG 10 N	0,60	0,85	710	1005	1,25
VAC 11 + HG 10 S	0,60	0,85	710	1005	1,50
VAC 12 + HG 10 N	0,60	0,85	1.250	1.770	2,85
VAC 12 + HG 10 S	0,60	0,85	1.250	1.770	3,20
VAC 15 + HG 15 N	0,60	0,85	1.476	2.091	3,40
VAC 15 + HG 15 S	0,60	0,85	1.476	2.091	3,75
VAC 20 + HG 15 N	0,60	0,85	2.724	3.859	7,25
VAC 20 + HG 15 S	0,60	0,85	2.724	3.859	7,60
VAC 30 + HG 30 N	0,60	0,85	4.086	5.789	11,50
VAC 30 + HG 30 S	0,60	0,85	4.086	5.789	12,00
VAC 40 + HG 40 N	0,60	0,85	5.448	7.718	20,00

\* Maximum suction power at 5 bar. For operation of a vibrator a higher pressure may be required.

Type	Air consumption [l/min]		Noise level * [dB(A)]	
	4 bar	6 bar	4 bar	6 bar
VAC 8 + HG 10 N	40	60	72	72
VAC 8 + HG 10 S	20	22	72	72
VAC 10 + HG 10 N	40	60	72	72
VAC 10 + HG 10 S	20	22	72	72
VAC 11 + HG 10 N	40	60	74	74
VAC 11 + HG 10 S	20	22	74	74
VAC 12 + HG 10 N	60	122	74	74
VAC 12 + HG 10 S	29	36	74	74
VAC 15 + HG 15 N	110	170	74	74
VAC 15 + HG 15 S	41	52	74	74
VAC 20 + HG 15 N	110	170	74	74
VAC 20 + HG 15 S	41	52	74	74
VAC 30 + HG 30 N	110	170	74	74
VAC 30 + HG 30 S	49	60	74	74
VAC 40 + HG 40 N	220	340	74	74

- The noise level was measured at a distance of 1 m without vibrator. The noise level of vibrators is in most cases higher.

**Dimensions:**

**VAC 8 / VAC 10 / VAC 11 / VAC 12**

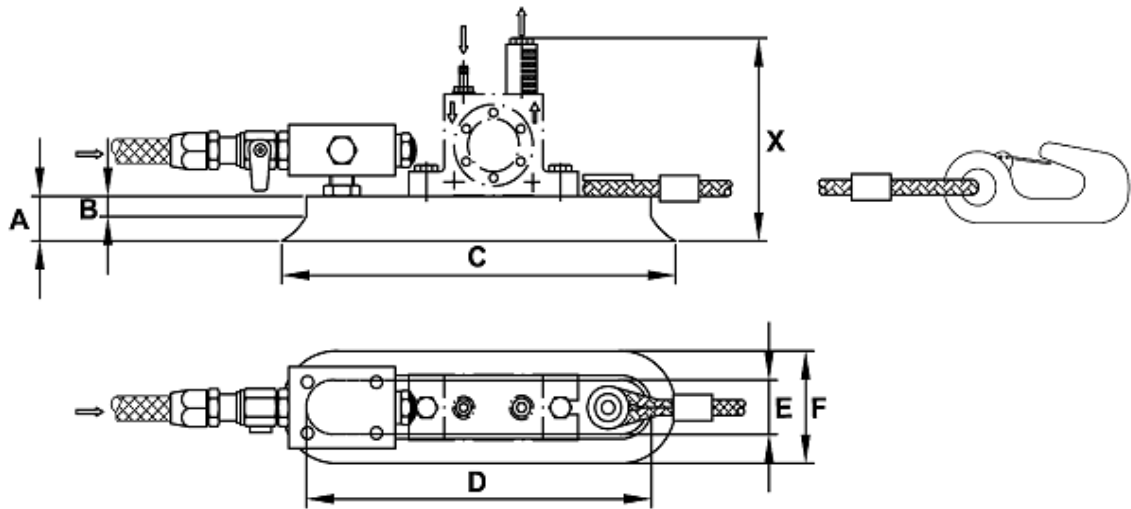

**VAC 15 / VAC 20**

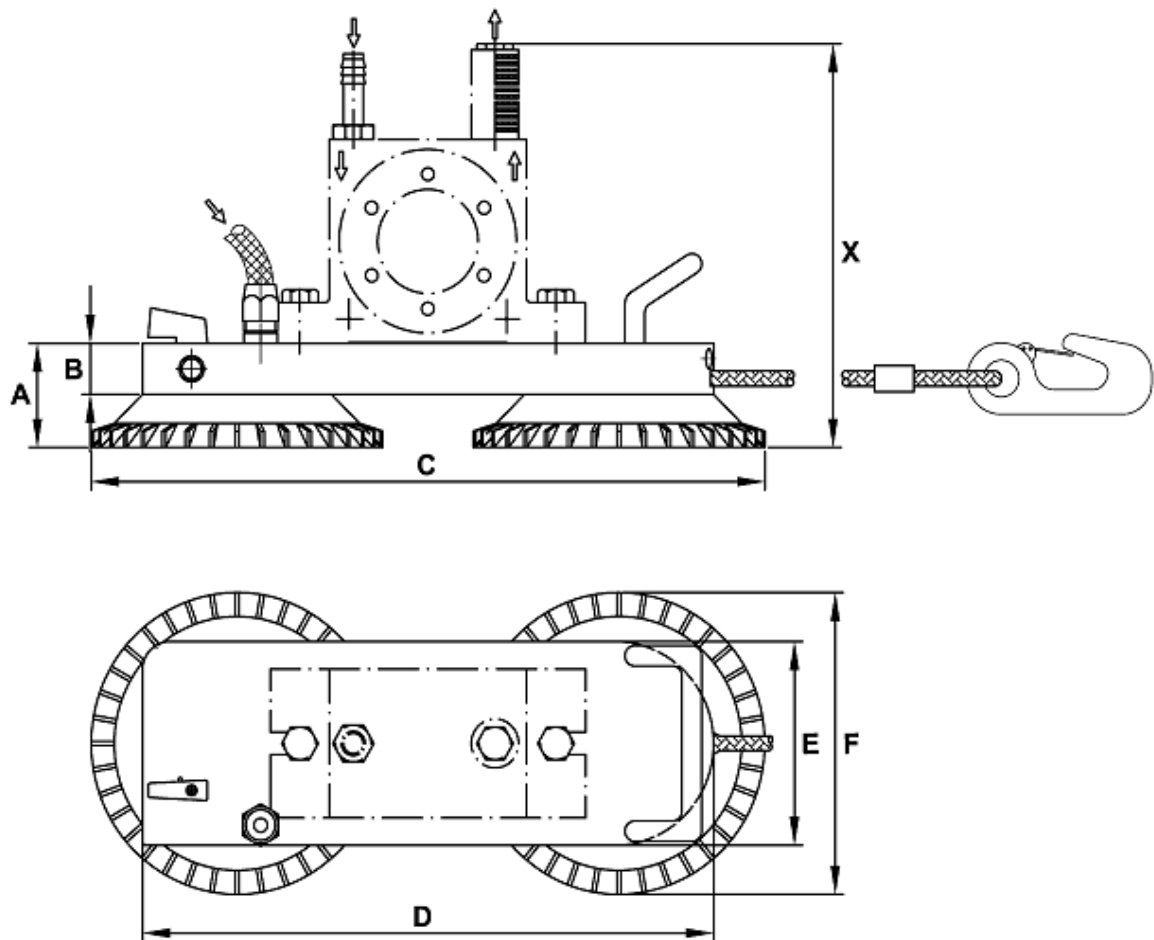

VAC 30

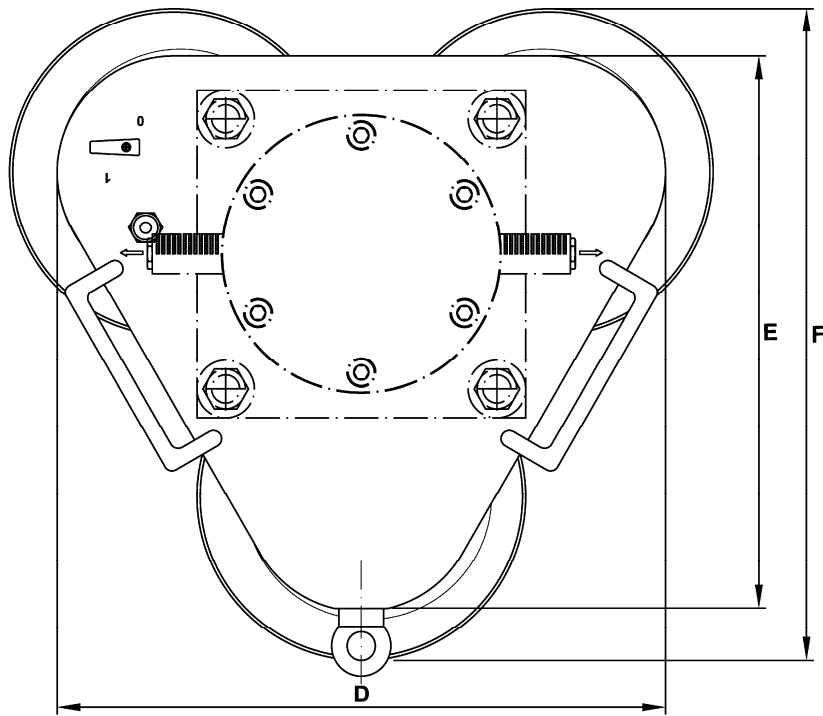
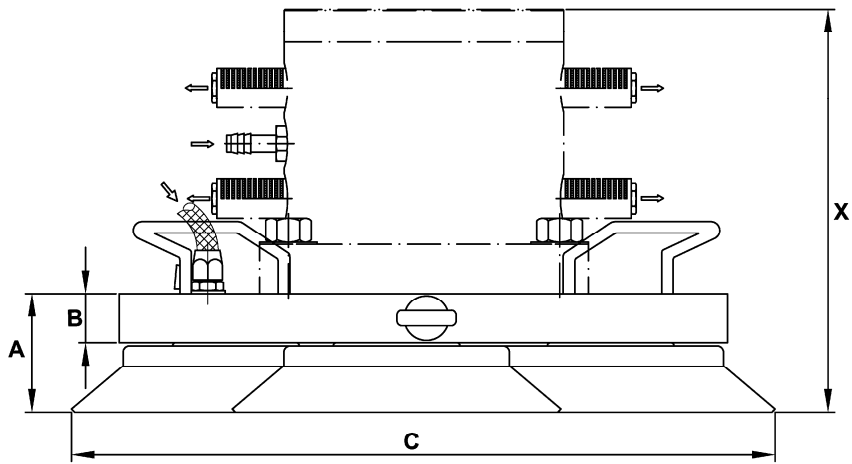

# VAC 40

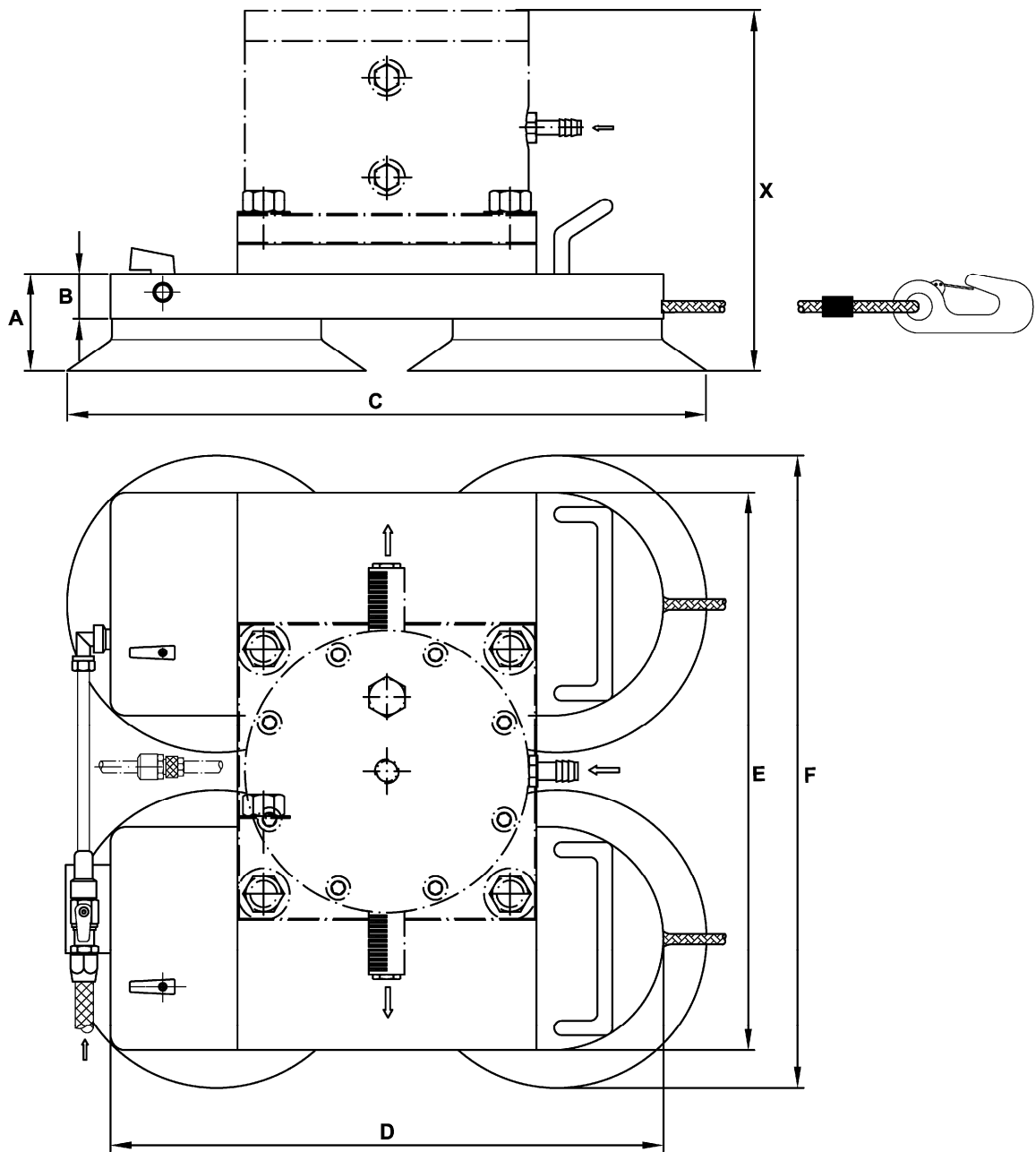

Typ	A	B	C	D	E	F
VAC 8	19	8	150	127	30	55
VAC 10	22	8	200	175	26,5	55
VAC 11	20	5,5	300	276	26	55
VAC 12	25	10	300	268	68	100
VAC 15	50	25	350	290	100	150
VAC 20	70	30	440	370	150	200
VAC 30	70	30	428	370	340	400
VAC 40	90	55	440	370	375	425

All dimensions in [mm] - measurement X depending on vibrator

### 3 Design and function

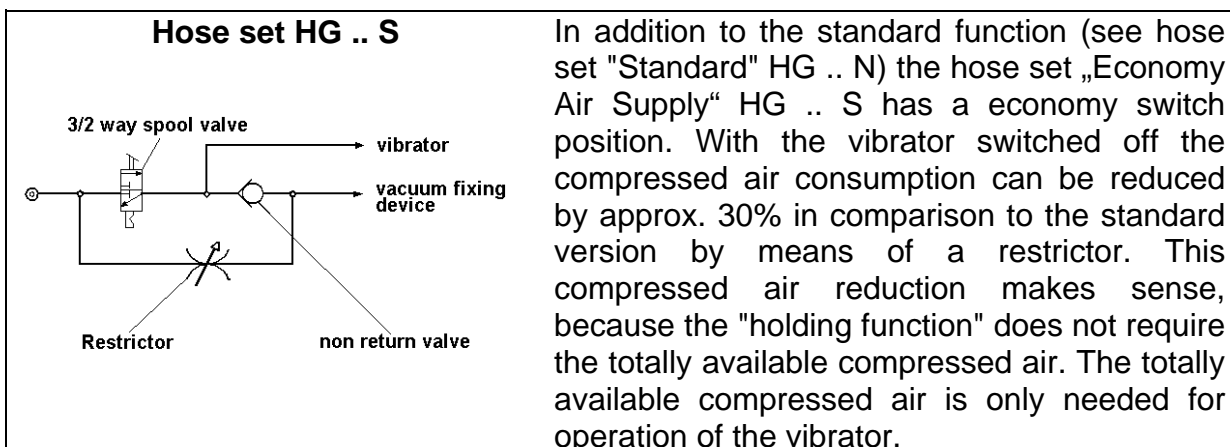
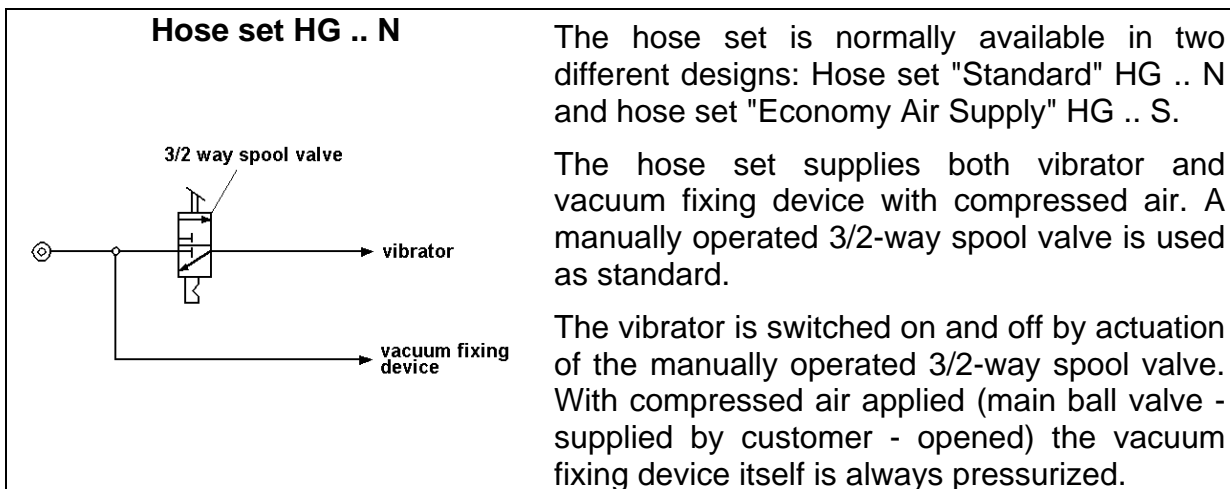
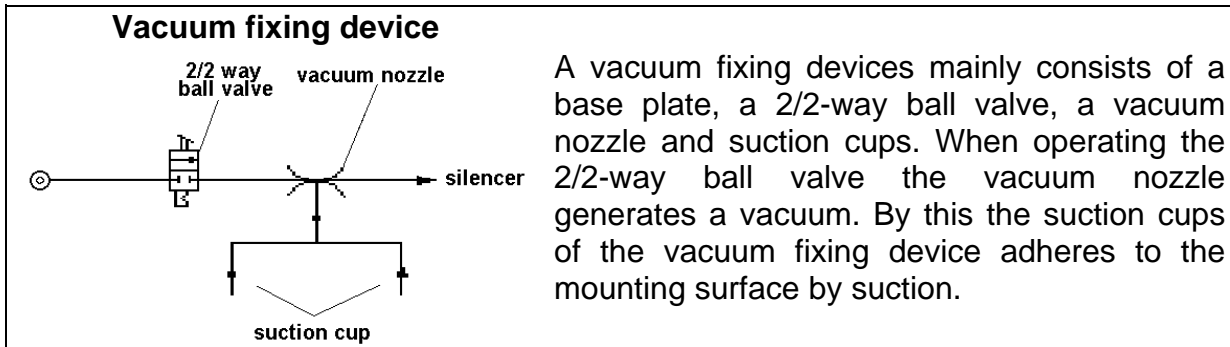
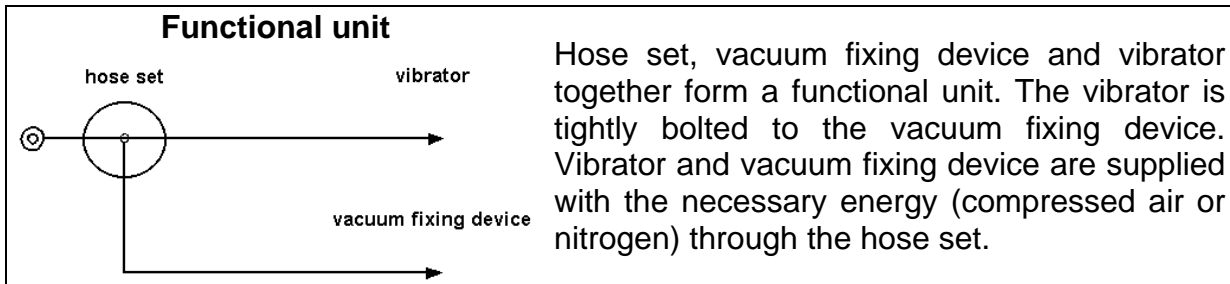



## 4 Safety



Vacuum fixing devices work with compressed air.  
 Make sure the compressed air supply is switched off during installation.  
 Disconnect the supply lines (quick coupling) before starting other work on holders, vibrators and on the supply lines.  
**Before starting operation all hoses must be tightly connected.**  
 A hose under pressure coming loose can cause severe injury.

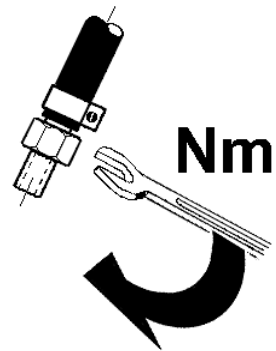

In case of an unexpected pressure drop the vacuum fixing devices may come loose. They should therefore be secured with a steel rope against dropping down.  
 From series VAC 11 the vacuum fixing devices are fitted with an adjustable safety rope. This rope must be pre-tensioned as short as possible using a bulldog grip. Should a holder come loose it should never drop into a slack rope.  
 A fixing device dropping down can cause bodily injury and/or damage to property.



When observing the minimum cross-sections ( $D_{min}$ ), vacuum fixing devices can also be mounted to round parts ( $\varnothing = D$ ):

VAC 8:	$D_{min}$ :	110 mm
VAC 10:	$D_{min}$ :	110 mm
VAC 11:	$D_{min}$ :	110 mm
VAC 12:	$D_{min}$ :	350 mm
VAC 15:	$D_{min}$ :	650 mm
VAC 20:	$D_{min}$ :	850 mm
VAC 30:	$D_{min}$ :	1.500 mm
VAC 40:	$D_{min}$ :	1.500 mm

With parts of smaller cross section there is a risk that a vacuum fixing device may come loose. A fixing device dropping down can cause bodily injury and/or damage to property.

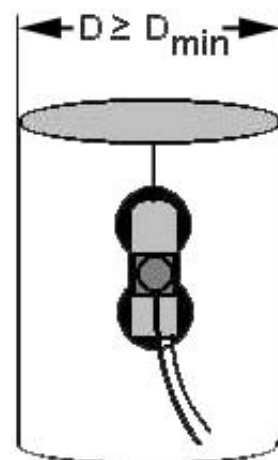



Vibrators bolted to vacuum fixing devices may come loose by the effect of vibration. Falling parts can cause damage to persons and material.

Screw retention components and/or Loctite or similar must be used. Screw connections must be checked and, if necessary, retightened after 1 hour of operation and then at regular intervals (normally every month).

Jan. / Feb. / ...

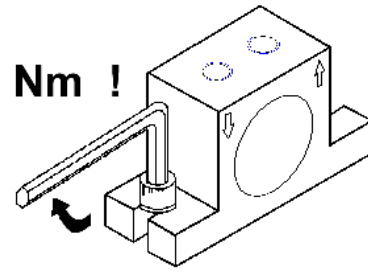

Not every pneumatic vibrator is suitable to the vacuum fixing device. Applicable vibrators are listed in chapter 6.2 „Mounting of vibrator and hose set“.

When choosing a different vibrator a preceding consultation is required.



**Technical changes to the equipment may effect the characteristics of these vacuum fixing devices or even damage the units and cause the rejection of any warranty claims.**

**Permissible operating conditions:**

**Operating pressure:**

4 bar to 6 bar\*

Operating pressures must not be exceeded or fall short of

**Temperature:**

-10°C to 60°C\*

Operating temperatures must not be exceeded or fall short of.

**Lubrication:**

VAC fixing devices do not require lubrication.

For the mounted vibrator lubricated compressed air may be specified.

Please refer to the corresponding operating instructions for the vibrator.

\*) Higher operating pressures and temperatures are only permitted after consultation and written confirmation by application engineers of Netter GmbH.



## 5 Transport and storage



Check the packing for possible shipping damage.

If the packing is damaged check the contents for completeness and possible damage. In case of damage inform the transport agent. Compare the scope of supply with the delivery note.

The vacuum fixing devices are packed ready for installation. The type designation is engraved on the base plate (exceptions: VAC 8, VAC 10, VAC 11 and VAC 12).

When ordering a vacuum fixing device in connection with hose set and vibrator, these components will be completely assembled, unless specified differently. Special transport conditions are not specified.

The units should be stored in boxes and in a dry and clean environment.

When returning vacuum fixing devices to the stores you should squirt some drops of oil into the air inlet. On complete units (hose set, vacuum holder and vibrator) the machine oil may also be squirted into the air inlet side of the hose set. The entire unit must subsequently be operated for a short moment.



The storage temperature may be between  $-20^{\circ}\text{C}$  and  $+80^{\circ}\text{C}$ .

(This does not apply for operating temperature, compare with **chapter 4 Safety, "Permissible Operating Conditions"**).



## 6 Installation



Make sure the compressed air supply is switched off during installation or any other work on vacuum fixing devices, vibrator or air supply lines.

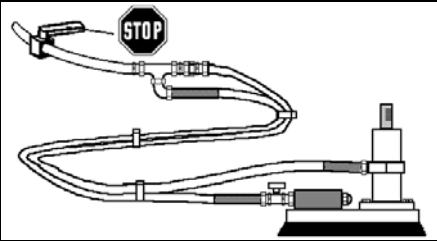

Complete vacuum fixing devices with hose set and vibrator are directly ready for operation.

If ordered separately, hose set and vibrator must first be assembled.

### 6.1 Connection of power supply

#### Supply line:

The pressure loss increases with the hose length. The following recommendations refer to hose lengths of max. 3 m to the next bigger hose cross section. For longer supply lines we recommend the use of bigger cross-sections, whereby the supplied hose socket can no longer be used.

#### Safeguard:

All vacuum fixing devices must be secured against dropping down. From series VAC 11 the vacuum fixing devices are fitted with an adjustable safety rope. With this rope pre-tensioned the fixing devices can be held (e.g. to eye bolts) in application position. Without this safeguard vacuum fixing devices must only be used if dropping down is impossible.

#### Minimum cross-sections for hoses:



A too small cross-section does not enable a sufficient vacuum.

Type	Hose socket	Hose size
HG 10 N / S	1/4"	NW 6
HG 15 N / S	3/8"	NW 9
HG 30 N / S	1/2"	NW 12
HG 40 N	1/2"	NW 12



The drive medium must be clean (filtered). Dirt will cause failure of the units. For certain vibrators the drive medium must additionally be lubricated. For more detailed information please refer to the operating instructions for the corresponding vibrator.

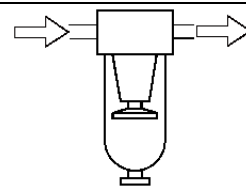

≤ 5 μm  
filter recommended

## 6.2 Mounting of vibrator and hose set

The following vibrators can be mounted to the vacuum fixing devices:

Type	Suitable vibrators
VAC 8	NCB 1, NCB 2, NCT 1, NCT 2, NTK 8 AL – NTK 18 AL, NTP 25 B+C**, NTS 120 - NTS 180 HF + NF*
VAC 10	NCB 1, NCB 2, NCR 3, NCT 3, NCT 4, NTP 25 B+C**, NTK 15x, NTK 18 AL, NTS 180 - NTS 250 HF + NF*, PKL 190
VAC 11	NCB 3, NCB 5, NCR 10, NCT 5, NCT 10, NTK 18 AL, NTS 180 – NTS 250 HF + NF, PKL 450**
VAC 12	NCB 10, NCB 20, NCR 22, NCT 15, NCT 29, NTP 32 B+C**, PKL 450**, PKL 740**, PKL 170*, NTK 25 AL, NTS 350 HF + NF, NTS 100/01, NTS 50/01
VAC 15	NCB 10, NCB 20, NCB 50, NCB 70, NCR 22, NCR 57, NCT 15, NCT 29, NCT 55, NCT 108, NTP 32 B+C, NTP 48+C*, NTK 18 AL, NTK 25, NTS 75/01, NTS 70/02* with round base plate, NTS 250 - NTS 350 HF + NF, PKL 740
VAC 20	NCR 57, NCT 55, NCT 108, NTP 32 B+C, NTP 48 B+C, NTS 50/04*, NTS 54/02, NTS 70/02, NTS 70/02 with round base plate
VAC 30	NCR 120, NCT 250, NTS 50/08*, NTS 50/04, PKL 2100, NVG 49/55/61, NVG 82/84*
VAC 40	NTS 50/08*, NTS 50/10*

\* consultation required, depending on individual case.

\*\* Adapter plate required, please add to your order.



Not every pneumatic vibrator is suitable to the vacuum fixing device. With drill patterns different to the ones for the above listed units the internal pilot bores may be damaged. The above mentioned combinations (fixing device/vibrator) have been tested and can be used without any limitations. When choosing a different vibrator a preceding consultation is required. Use screw retentions and nuts to fasten the vibrator. Use a liquid screw retention agent (e.g. Loctite) against loosening. Use tightening torques according to the following table. Higher tightening torques may cause fracture of screws or tearing of threads. Inadequate screw connections may cause loosening of units by vibration. This can cause damage to persons and material!

### Recommended mean tightening torques for screws of quality 8.8 (screws as supplied, without additional lubrication):

Thread	Tightening torque [Nm]
M 6	10,4
M 8	25,0
M 10	51,0
M 12	87,0
M 16	215,0
M 20	430,0



Vibrators must be cautiously and properly fastened. The fastening screws for the vibrator must be retightened or checked after 1 operating hour.

**Vacuum fixing devices should be used in combination with the following hose sets:**

Type	Hose set (except PKL)	Hose set for PKL
VAC 8	HG 10 N or HG 10 S	
VAC 10	HG 10 N or HG 10 S	
VAC 11	HG 10 N or HG 10 S	HG 10 N or HG 10 S
VAC 12	HG 15 N or HG 15 S	HG 10 N or HG 10 S
VAC 15	HG 15 N or HG 15 S	HG 10 N or HG 10 S
VAC 20	HG 15 N or HG 15 S	HG 10 N or HG 10 S
VAC 30	HG 30 N or HG 30 S	HG 10 N or HG 10 S
VAC 40	HG 40 N	

Of the two branching off hoses the hose permanently pressurized is to be connected to the vacuum fixing device and the hose that can be switched off to the vibrator.

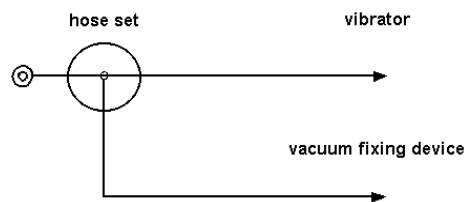

### 6.2.1 VAC 8, VAC 10, VAC 11 and VAC 12

**Vibrator:**

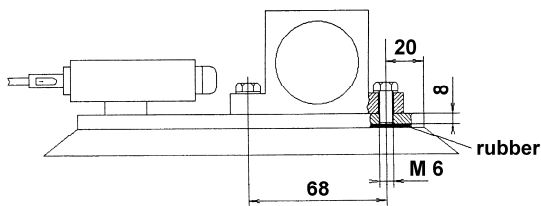

In order to mount vibrators NCB, NCR or NCT to a VAC 8, VAC 10, VAC 11 or VAC 12 two tapped blind holes must be drilled.

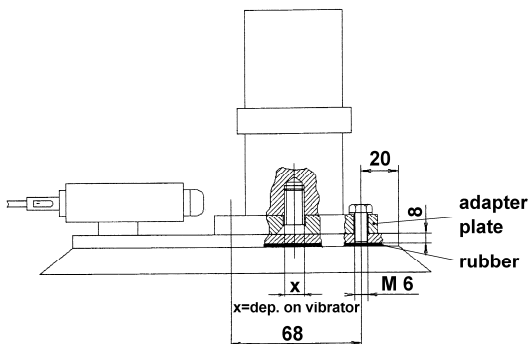

If a compressed air operated piston vibrator of series NTS or NTK is to be mounted, we recommend the use of an adapter plate.

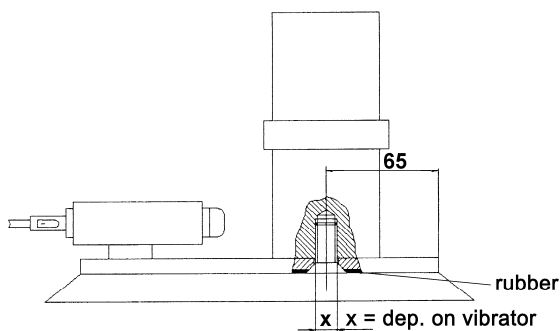

Otherwise one hole must be drilled into the suction cup and the tapped hole sealed with a sealing agent (e.g. Loctite). For the size of thread refer to the operating instructions for the respective vibrator.



When drilling blind holes make sure not to drill through the suction cup (rubber). However, if this should happen, you must seal the tapped holes with a sealing compound (e.g. Loctite), as otherwise no vacuum can be generated.

## 6.2.2 VAC 15, VAC 20 and VAC 30

### Vibrator:

In order to mount the vibrator to a VAC 15 or VAC 20 socket head cap screws acc. to DIN 7991 are required. The assembly can be performed as follows:

1. Unscrew the suction cups.
2. Determine and mark the necessary bore holes (commonly used bore pitches have already been marked with a centre punch, see template VAC 15 and VAC 20).
3. Drill through-holes (diameter depending on type of vibrator - see operating instructions for vibrator). Countersink bores from bottom side of base plate (side of suction cup) acc. to DIN 74-Bf....
4. Fasten the vibrator using the specified socket head cap screws. For this purpose use common screw retentions.
5. Assemble the suction cups in the correct position with both O-rings.



For assembly of the PKL 740 to the VAC 15 an adapter plate is required, if the inlay EE is not used.

### Template VAC 15

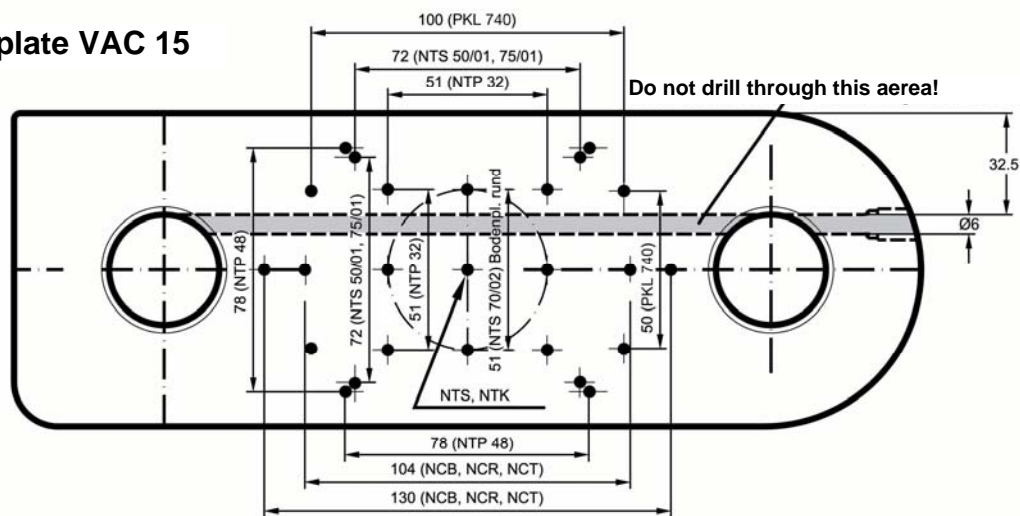

T(

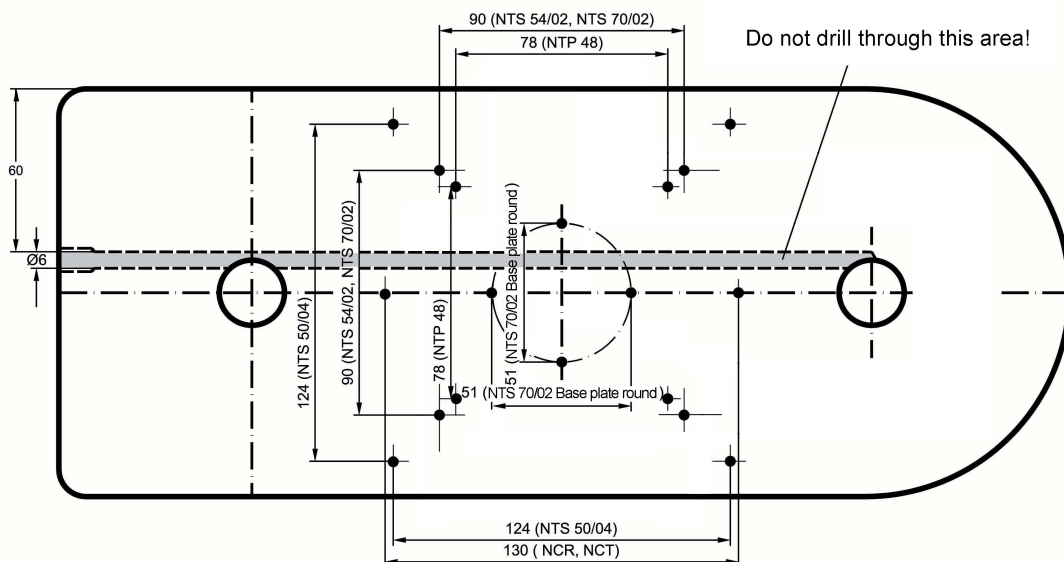

## Template VAC 30

Do not drill through this area!

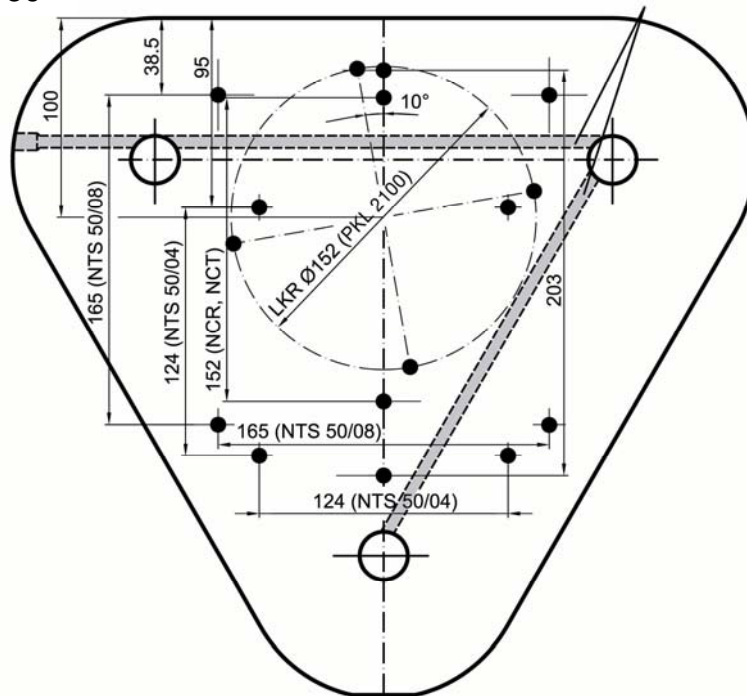

### 6.2.3 VAC 40

#### Vibrator:

The VAC 40 consists of two VAC 20, which are connected by an adapter plate. The vibrator is mounted to the adapter plate. For the fastening of a compressed air operated piston

vibrator series NTS 50/10 the adapter plate has four through holes. For the fastening of any other vibrator you should consult Netter beforehand.

#### Checklist for installation:

- 1) Attach the vibrator. Lock the fastening screws.
- 2) Assemble the hose set.
- 3) Install the service unit (filter, if necessary regulator and lubricator), valve, supply line.
- 4) Check!  
Have fastening screws been locked?  
Has information on hose length and nominal width been observed?



## 7 Start-up / operation

After completion of assembly work the vacuum fixing device is ready for operation.

The vacuum fixing device can be operated with filtered compressed air

or nitrogen. For operation of certain vibrators a lubricated drive medium is specified. For more details refer to the operating instructions for the respective vibrator.



In case of an unexpected pressure drop the vacuum fixing devices may come loose. They should therefore be secured with a steel rope against dropping down. From series VAC 11 the vacuum fixing devices are fitted with an adjustable safety rope. This rope must be pre-tensioned as short as possible using a cable clamp. Should a fixing device come loose it should never drop into a slack rope. A fixing device dropping down can cause bodily injury and/or damage to property.



### Handling:

Secure the vacuum fixing device against dropping down and attach it to the part to be vibrated. Operate the 2/2-way ball valve on the holder in order to generate the required vacuum. Check the vacuum fixing device for tight and secure attachment. If the fixing device can be loosened by hand, you should increase the pressure (e.g. on service unit with pressure regulator). Then start the vibrator by actuating the manual 3/2-way spool valve on the hose and adjust the lubricator.

Adjust the desired vibrator frequency with a pressure regulator (option - e.g. part of a service unit).

When using a vacuum fixing device with hose set HG .. S you may activate the Economy Air Supply function. For this purpose turn the restrictor screw in clockwise direction, until the fixing device can be easily moved by hand. Then start the vibrator by actuating the manual 3/2-way spool valve on the hose, the full vacuum will be generated.



Adjust the lubricator while the vibrator is running. Exact details concerning oil quality and quantity can be taken from the operating instructions for the vibrator.



When relocating the vacuum fixing device with hose set HG .. S to another surface the economy air supply function must be readjusted or checked on the restrictor screw.

### Checklist for commissioning:

- 1) Check! Has the VAC been secured against falling down?
- 2) Check all hose connections before opening the air supply.
- 3) Adjust the lubricator, if present.
- 4) If necessary adjust the required frequency on the pressure regulator.



Screw connections must be checked and, if necessary, retightened after 1 hour of operation and then at regular intervals (normally every month).

## 8 Service, maintenance



Before starting inspection and service work shut off the compressed air supply and secure it against unintended activation!

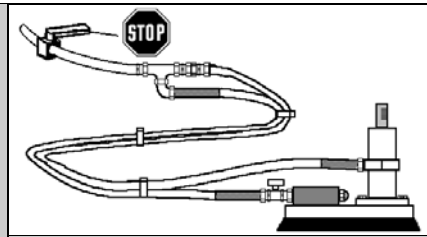

Check the fastening of vibrator and air supply connection at regular intervals - normally every month. The service intervals for other components are partly shorter, they may vary extremely, in dependence on vibrator and environmental conditions.

### Lubricator:

With a lubricator connected in series make sure that the lubricator works as specified (contents diminishing? number of drops/min? top up oil if necessary).

### Cleaning:

Vacuum fixing devices may be cleaned from outside with pressurized water. After clean run the unit for a short moment.

### Silencer:

Clogged silencers adversely affect the power of vacuum fixing devices and vibrators. In extreme cases it may even lead to failure of the units. Silencers should therefore be serviced at regular intervals and washed out with petroleum ether, if required. The maintenance intervals mainly depend on the purity of your drive medium and the environmental conditions.

### Filter:

Empty the filter when required, clean the filter insert (wash out).

### Suction cups:

The suction cups must be permanently checked for wear and need to be replaced if necessary.

### Securing rope:

If the safety rope has been extremely loaded by the vacuum fixing device dropping down, it should be replaced by a new one.

### Vacuum nozzle:

The vacuum nozzle may be clogged by contaminated drive air. In this case the nozzle must be disassembled and cleaned in petroleum ether.

On VAC 8, VAC 10, VAC 11 and VAC 12 the externally arranged vacuum nozzle is easy to disassemble and clean.

Disassembly and cleaning of vacuum nozzles on VAC 15, VAC 20, VAC 30 and VAC 40 should only be performed by **NetterVibration**.



When servicing the unit please observe the safety regulations in chapter 4.

## 9 Troubleshooting

<b>Fault</b>	<b>Possible cause</b>	<b>Trouble shooting</b>	<b>Remedy</b>
Vacuum fixing devices does not generate any vacuum	Air supply	Check pressure before holder. Hose set correctly assembled? For economic air supply check setting of restrictor. Hoses kinked? Sufficient cross-section of supply line?	Adjust pressure to 3 bar to 6 bar. Assemble hose set correctly. Adjust restrictor. Route hoses without kinks. Enlarge the supply line cross-section.
	Silencer on fixing device clogged	Performance test without silencer.	Wash out or replace, as required
	Vacuum nozzle clogged		Clean (procedure is described in chapter „Maintenance and Repair“.)
	Suction surface	Is the suction surface air-permeable and/or rough?	If yes, the vacuum fixing device is not suitable for this application.
Vacuum fixing devices slips during vibration	Air supply	Hoses kinked?	Route hoses without kinks.
	Silencer clogged		Wash or replace
	Vacuum nozzle clogged		Clean (procedure is described in chapter „Maintenance and Repair“.)
	Suction surface	Is the suction surface air-permeable?  Is the suction surface oily, greasy or wet?	If yes, the vacuum fixing device is not suitable for this application. Remove the respective layers.
	Suction cups worn		Replace suction cups
	Extremely massive base (rebounds)		Mount fixing device to the elastic base between stiffeners (diaphragm effect).

## 10 Spare parts

When ordering spare parts please give the following details:

1. Required quantity
2. Description and position of the spare part (see spare parts list)
3. Type of unit

## 11 Appendix

### 11.1 Accessories

The following accessories are available for vacuum fixing devices (on request):

Description	Remark
Hose material and fittings	For supply and discharge of compressed air in various qualities and dimensions
3/2 or 2/2 way valves	For electric, pneumatic and manual control
Restrictor valves	For rotary speed control, manually adjustable or pneumatically controllable (for remote control)
Service units	Filter, regulator, lubricator
Duty/pause control	Electric or pneumatic for interval operation
<b>SPECIAL DESIGNS:</b>	Some vacuum fixing devices are also available as special versions, e.g. with stainless steel plate, for extreme temperature ranges with suction cups made of silicone. Further information on request.

### 11.2 Waste disposal

Depending on the material, the parts must be disposed of according to regulations.

#### Material specifications:

- Clamping plate ⇒ VAC 8 - 12 steel
- Suction cups (black or anthracite) ⇒ VAC 15 - 40 aluminium
- Fittings ⇒ Rubber
- Fittings ⇒ Brass, nickel plated

Special units: Material on request (e.g. suction cups made of silicone)



All units can be disposed off through Netter GmbH.  
The valid disposal prices are available on request.

### 11.3 Enclosures

#### Enclosure(s):

Declaration of manufacturer  
Spare parts lists



**Further information available on request:**  
Leaflet no. 15 (VAC), and more