

CLOCK

TROUBLESHOOTING

BE060-13

HINT:

Troubleshoot the clock according to the table below.

Troubleshooting	No.
Passenger seat belt warning light does not light up.	1
Clock will not operate	1
Clock loses or gains time	2

± 1.5 seconds / day

1. INSPECT CLOCK CIRCUIT (See page [DI-1009](#))

2. TROUBLESHOOTING NO. 1

1	PASSENGER SEAT BELT WARNING LIGHT DOES NOT OPERATE
	CLOCK WILL NOT OPERATE

(a) Check that the battery positive voltage is 10 - 16 V.

If voltage is not as specified, replace the battery.

(b) Check that the MPX-B and RAD No. 2 fuses are not blown.

If the fuse is blown, replace the fuse and check for short.

(c) Troubleshoot the clock as follows.

HINT:

Inspect the connector on the wire harness side.

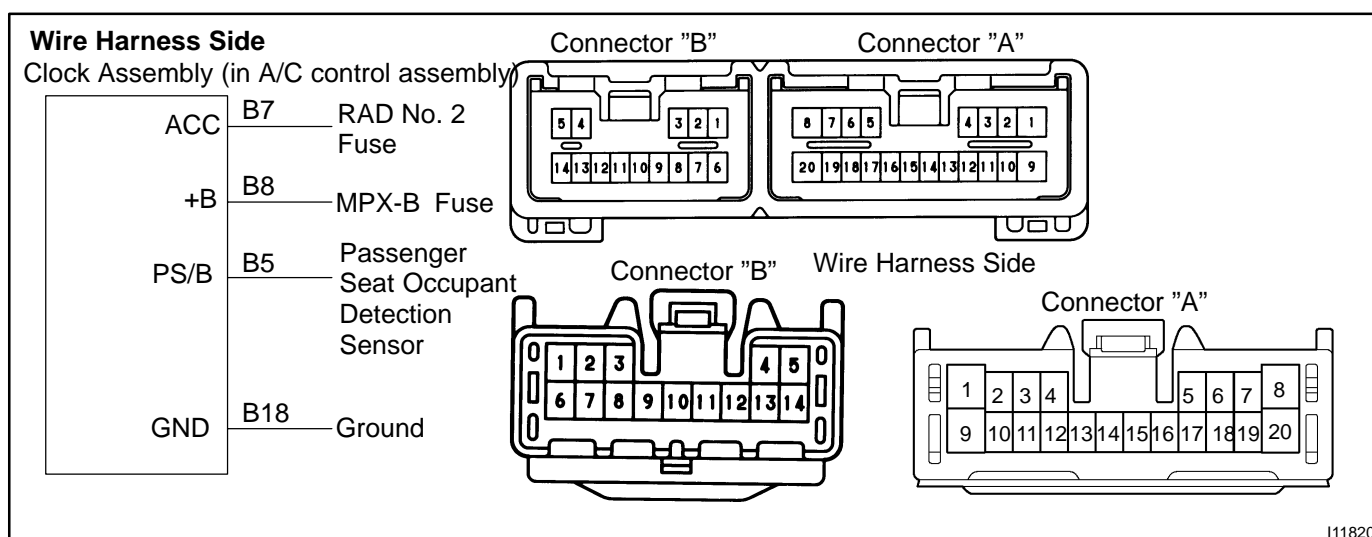

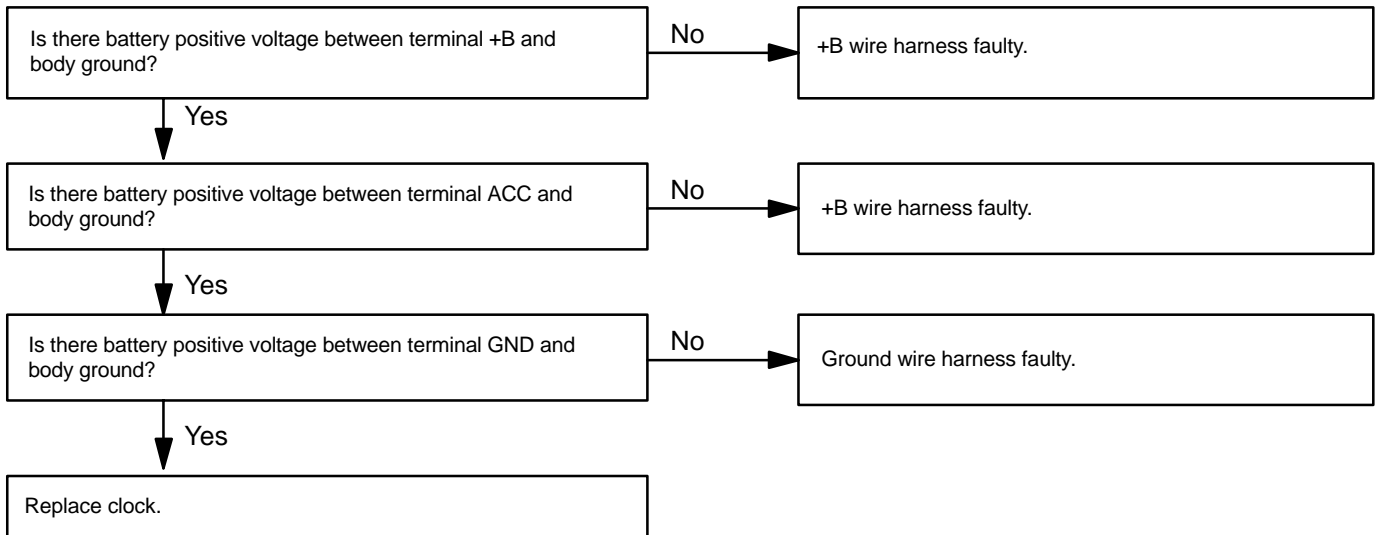

3. TROUBLESHOOTING NO. 2

2	CLOCK LOSES OR GAINS TIME
---	----------------------------------

(a) Check that the battery positive voltage is 10 - 16 V.
If voltage is not as specified, replace the battery.

(b) Inspect the error of the clock.

Allowable error (per day): ± 1.5 seconds

If the error exceeds the allowable error, replace the clock.

(c) Check that the clock adjusting button is sticking in position and has failed to return.
If the error exceeds the allowable error, replace the clock.

(d) Troubleshoot the clock as follows.

HINT:

Inspect the connector on the wire harness side.

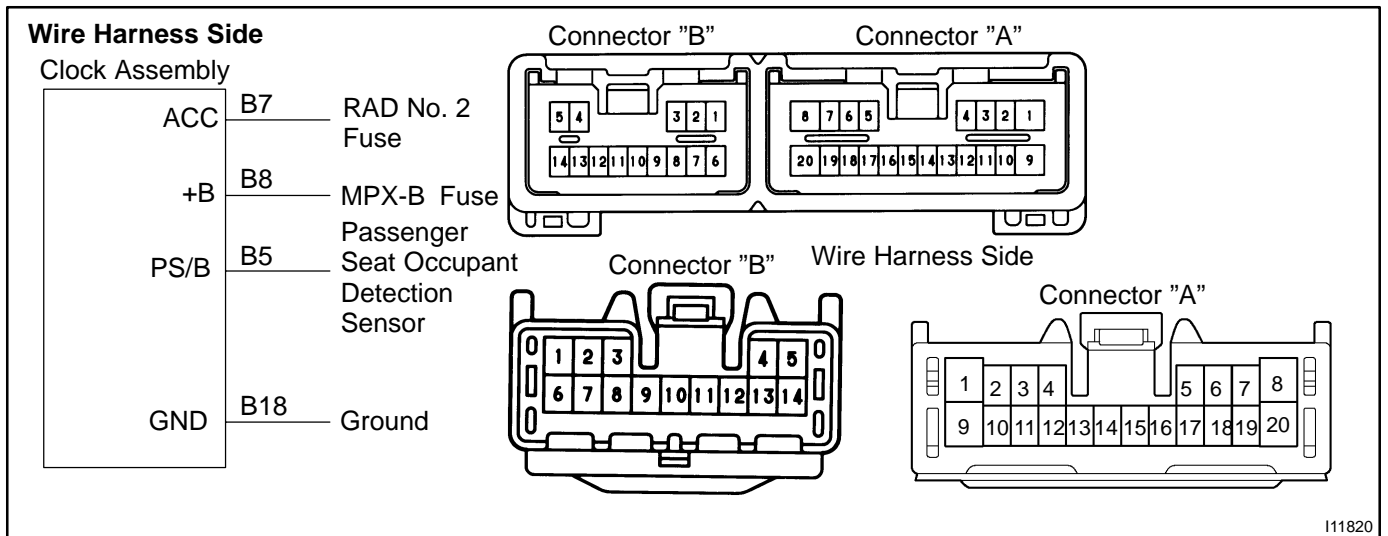

BODY ELECTRICAL - CLOCK

