

**DISPLAY EDITOR**

**(Machine Code: A997)**

---

# 1. SPECIFICATIONS

Original Size:	Maximum: A3 (lengthwise) or 11" x 17" (lengthwise) (Scanned through the copier.)
Display:	LCD (Monochrome), 8 gradations 640 x 480 dots
Zoom In/Out:	100% (33 dpi), 150% (50 dpi), 200% (67 dpi), 300% (100 dpi)
Display Speed:	Less than 2 seconds
Editing:	Screen and cursor
Power Consumption:	19.5W
Power Source:	5V/less than 1.5A and 24V/less than 10.5 from the copier.
Dimensions (W x D x H):	280 x 232 x 50 mm 11.0" x 9.14" x 1.97"
Weight:	less than 1.5 Kg or 33.1 lb
Remarks:	The holder is required for installation.

## 2. OVERVIEW

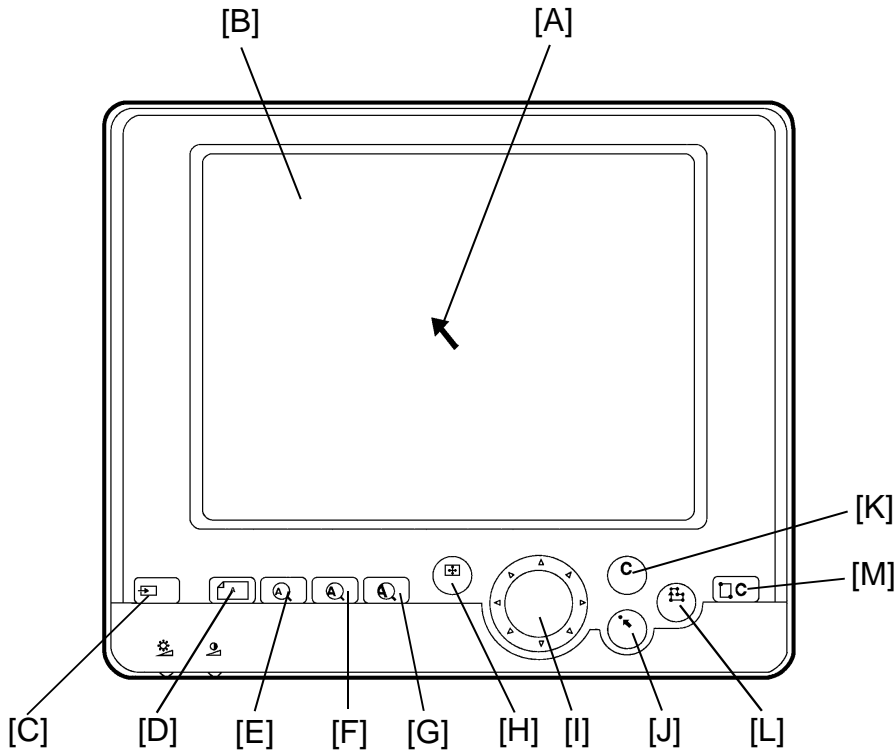

The scanned image is sent to the display editor and displayed on the LCD (640 x 480 dot).

By using the cursor [A], it is able to designate an area of the original image. The display [B] shows 8 levels of grayscale, and the data communication between the display editor and the IPU board is done by 3 bit parallel signal.

### 3. EXPLANATION FOR EACH KEY

Key	Function
Scan Key [C]	Sends the scan start command to the copier, and scanning of the original is performed. After the scanning, the entire original image is shown on the display editor (100%).
Full Image Key [D]	The data scanned with 100 dpi is changed to about 33 dpi. The entire A3 or DLT original image can be displayed.
Zoom 1 Key [E]	The data scanned with 100 dpi is changed to 50 dpi. (150% enlargement)
Zoom 2 Key [F]	The data scanned with 100 dpi is changed to about 67 dpi. (200% enlargement)
Zoom 3 Key [G]	The data scanned with 100 dpi is displayed with about 100 dpi. (300% enlargement)
Image Shift Key [H]	Press to shift the image up and down, left and right by using the cursor key according to the block diagram displayed at the lower left corner.
Cursor Key [I]	The cursor on the display will appear at the center after pressing the scan key, zoom keys and image shift key. The cursor shown on the display will move to the desired position by pressing this key.
Point Key [J]	Sends the information of the current location of the cursor to the copier.
Clear Key [K]	The previously marked point before pressing the close key will be canceled.
Close Key [L]	Press to close an area.
All Clear Key [M]	All specified dimensions or areas will be canceled.

---

## 4. INSTALLATION

### 4.1 ACCESSORY CHECK

Check the accessories according to the following list:

Description	Q'ty
1. Key Description Decal .....	1
2. Cable .....	1
3. Harness Clamp.....	2
4. Truss Screw.....	4

## 4.2 INSTALLATION PROCEDURE

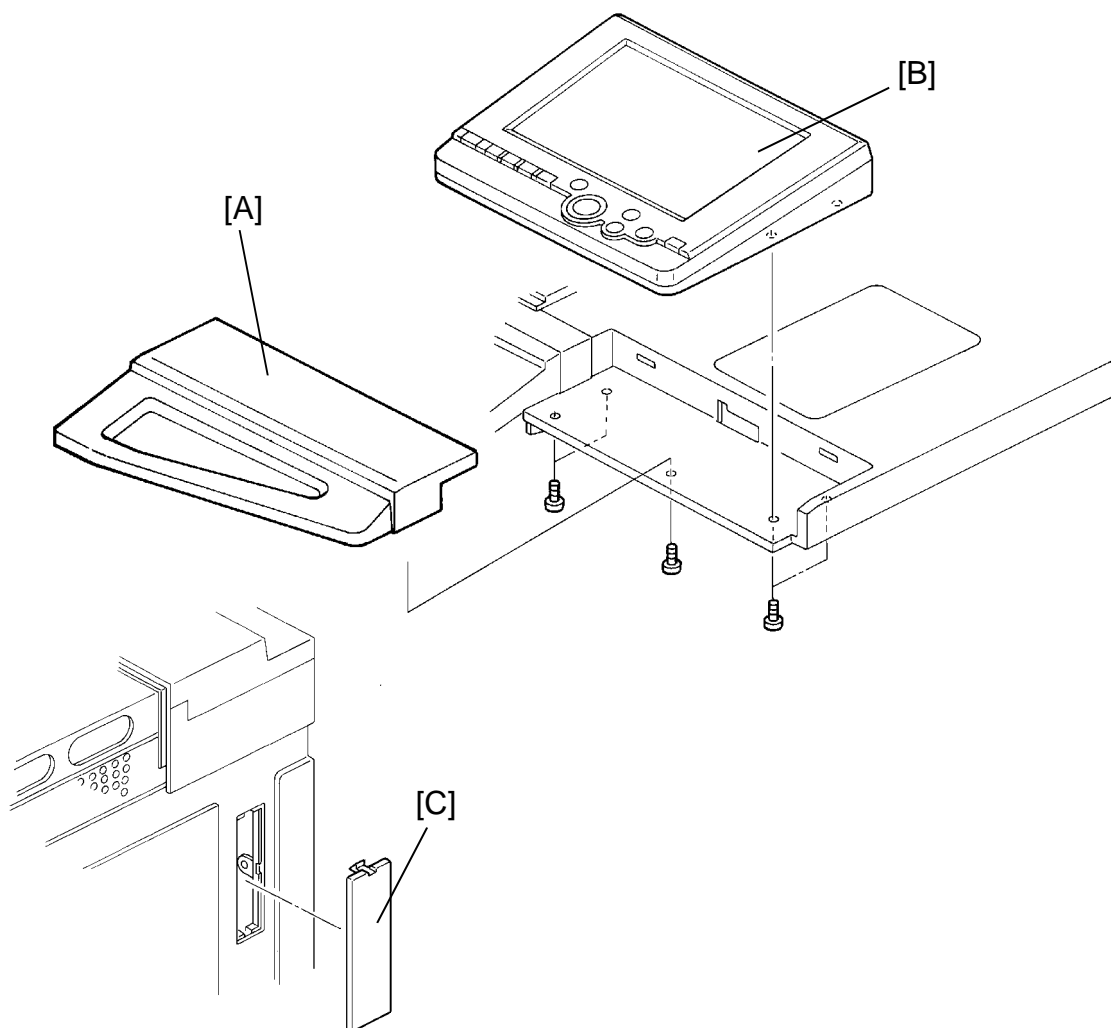

**CAUTION:** When installing the display editor, make sure that the copier is unplugged.

**NOTE:** Holder (A702) must be installed before starting the following procedure.

1. Remove the front cover [A].
2. Install the display editor [B] (4 screws).
3. Remove the small cover [C].

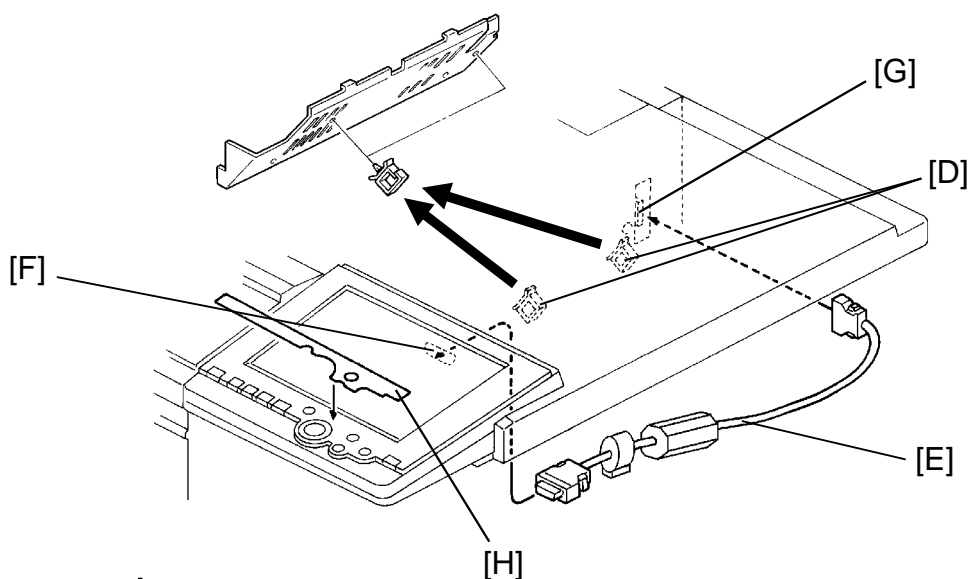

4. Install the 2 harness clamps [D] to the lower cover of the optional table.
5. Connect the cable [E] to the connector [F] of the display editor and to the connector [G] of the copier.
6. Set the cable to the 2 wire cramps.
7. Plug in the power cord and turn on the main switch.
8. Enable the editor operation by selecting "Display" in the SP modes (page 4-11, No. 417 Editor).
9. Turn the main switch off and on.
10. Stick the key description decal [H] as necessary.
11. Check the machine operation.