

# PM3200 series

## Power Meters User Manual

06/2012



---

The information provided in this documentation contains general descriptions and/or technical characteristics of the performance of the products contained herein. This documentation is not intended as a substitute for and is not to be used for determining suitability or reliability of these products for specific user applications. It is the duty of any such user or integrator to perform the appropriate and complete risk analysis, evaluation and testing of the products with respect to the relevant specific application or use thereof. Neither Schneider Electric nor any of its affiliates or subsidiaries shall be responsible or liable for misuse of the information that is contained herein. If you have any suggestions for improvements or amendments or have found errors in this publication, please notify us.

No part of this document may be reproduced in any form or by any means, electronic or mechanical, including photocopying, without express written permission of Schneider Electric.

All pertinent state, regional, and local safety regulations must be observed when installing and using this product. For reasons of safety and to help ensure compliance with documented system data, only the manufacturer should perform repairs to components.

When devices are used for applications with technical safety requirements, the relevant instructions must be followed.

Failure to use Schneider Electric software or approved software with our hardware products may result in injury, harm, or improper operating results.

Failure to observe this information can result in injury or equipment damage.

© 2012 Schneider Electric. All rights reserved.

---

# Table of Contents



	<b>Safety Information</b> .....	<b>5</b>
	<b>About the Book</b> .....	<b>7</b>
<b>Chapter 1</b>	<b>Presentation</b> .....	<b>9</b>
	Presentation .....	10
	Physical Description .....	11
<b>Chapter 2</b>	<b>Installation</b> .....	<b>13</b>
	Safety Measures .....	14
	Dimensions .....	15
	DIN Rail Mounting and Dismantling .....	16
	Connection .....	18
<b>Chapter 3</b>	<b>Functions</b> .....	<b>25</b>
	Metering .....	26
	Alarms .....	31
	Input/Output Capabilities .....	34
	Multi-tariff .....	36
	Data Logging (PM3255) .....	39
<b>Chapter 4</b>	<b>Operation</b> .....	<b>41</b>
	Presentation .....	42
	Configuration Mode .....	43
	Modifying Parameters .....	49
	Clock Setting .....	50
	Display Mode .....	51
	Full Screen Mode .....	59
<b>Chapter 5</b>	<b>Communication via Modbus RS-485</b> .....	<b>61</b>
5.1	Modbus Configuration .....	62
	Configuration of RS-485 Communication Port .....	62
5.2	Modbus Functions .....	63
	Function List .....	64
	Table Format .....	65
5.3	Command Interface .....	66
	Presentation .....	67
	Command List .....	68
5.4	Modbus Register Table .....	74
	Register List .....	74
5.5	Read Device Identification .....	89
	Register List .....	89
<b>Chapter 6</b>	<b>Technical Characteristics</b> .....	<b>91</b>
	Specifications .....	91
<b>Chapter 7</b>	<b>Maintenance and Troubleshooting</b> .....	<b>93</b>
	Safety Precautions .....	94
	Password Recovery .....	95
	Language Download .....	96
	Troubleshooting .....	97
<b>Appendices</b>	.....	<b>99</b>
<b>Appendix A</b>	<b>Power Factor Register Format</b> .....	<b>101</b>
	Register Format in Power Factor .....	101
<b>Appendix B</b>	<b>Abbreviations and Symbols</b> .....	<b>103</b>
	Abbreviations and Symbols .....	103



---

# Safety Information

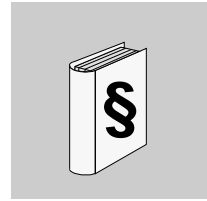

---

## Important Information

### NOTICE

Read these instructions carefully, and look at the equipment to become familiar with the device before trying to install, operate, or maintain it. The following special messages may appear throughout this documentation or on the equipment to warn of potential hazards or to call attention to information that clarifies or simplifies a procedure.



The addition of this symbol to a Danger safety label indicates that an electrical hazard exists, which will result in personal injury if the instructions are not followed.



This is the safety alert symbol. It is used to alert you to potential personal injury hazards. Obey all safety messages that follow this symbol to avoid possible injury or death.

### **DANGER**

**DANGER** indicates an imminently hazardous situation which, if not avoided, **will result in** death or serious injury.

### **WARNING**

**WARNING** indicates a potentially hazardous situation which, if not avoided, **can result in** death or serious injury.

### **CAUTION**

**CAUTION** indicates a potentially hazardous situation which, if not avoided, **can result in** minor or moderate injury.

### **NOTICE**

**NOTICE** is used to address practices not related to physical injury.

### PLEASE NOTE

Electrical equipment should be installed, operated, serviced, and maintained only by qualified personnel. No responsibility is assumed by Schneider Electric for any consequences arising out of the use of this material.

A qualified person is one who has skills and knowledge related to the construction and operation of electrical equipment and its installation, and has received safety training to recognize and avoid the hazards involved.



---

## About the Book

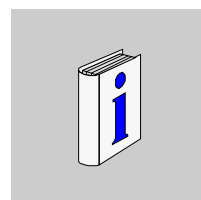

---

### At a Glance

#### Document Scope

This manual is intended for use by designers, system builders, and maintenance technicians who are concerned with electrical distribution systems featuring monitoring devices.

#### Validity Note

The power meters are used to measure electrical parameters of an installation or a part of an installation.

This function meets the requirements for:

- installation monitoring,
- alarming on consumption drifts,
- consumption monitoring,
- evaluation of energy items (cost, accounting, and so on.),
- logging of historical consumption,
- identifying harmonic disturbances.

This function also satisfies the power-saving incentives implemented by many countries.

#### Related Documents

Title of Documentation	Reference Number
Power Meters Instruction sheet: PM3200 / PM3210 (Chinese, English, French, German, Italian, Portuguese, Russian, Spanish)	S1B46605
Power Meters Instruction sheet: PM3200 / PM3210 (Czech, Danish, Dutch, Finnish, Hungarian, Norwegian, Polish, Swedish)	S1B62913
Power Meters Instruction sheet: PM3250 / PM3255 (Chinese, English, French, German, Italian, Portuguese, Russian, Spanish)	S1B46607
Power Meters Instruction sheet: PM3250 / PM3255 (Czech, Danish, Dutch, Finnish, Hungarian, Norwegian, Polish, Swedish)	S1B62914

You can download these technical publications and other technical information from our website at [www.schneider-electric.com](http://www.schneider-electric.com).

#### User Comments

We welcome your comments about this document. You can reach us by e-mail at [techcomm@schneider-electric.com](mailto:techcomm@schneider-electric.com).





---

# Presentation



---

## What Is in This Chapter?

This chapter contains the following topics:

Topic	Page
Presentation	10
Physical Description	11

## Presentation

### Use of Power Meters to Measure Electrical Systems

The power meters provide accurate 3-phase electrical parameters monitoring.

The offer is composed of 4 commercial references described below.

### Functions of Power Meters

The product functions of power meters provide the various measurement capabilities required to monitor an electrical installation such as current, voltage, power, power factor, frequency and energy.

The key features of power meters are:

- electrical parameters monitoring such as I, In, U, V, PQS, E, PF, Hz,
- power/current demand, peak demand,
- time stamped alarms,
- minimum/maximum,
- up to 4 tariffs management,
- up to 2 digital inputs and 2 digital outputs,
- Modbus communication.

### Main Characteristics

Function	PM3200	PM3210	PM3250	PM3255
Measurement inputs through CTs (1 A, 5 A)	√	√	√	√
Measurement inputs through VTs	√	√	√	√
Four quadrant energy measurements	√	√	√	√
Electrical measurements (I, In, V, PQS, PF, Hz)	√	√	√	√
THD current and voltage	–	√	√	√
Current, power demand, present	√	√	√	√
Current, power demand, peak	–	√	√	√
Minimum/Maximum of instantaneous values	√	√	√	√
Power demand logs	–	–	–	√
Energy consumption log (day, week, month)	–	–	–	√
Multi-tariff (internal clock)	4	4	4	4
Multi-tariff (external control by DI)	–	–	–	4
Multi-tariff (external control by communication)	–	–	4	4
Measurement display	√	√	√	√
Digital inputs/Digital outputs	–	0/1	–	2/2
Alarms with time stamping	–	5	5	15
Modbus communication	–	–	√	√
Width (18 mm module in DIN Rail mounting)	5	5	5	5

## Physical Description

### PM3200 / PM3210

The various features of the listed power meters are shown in the diagram below:

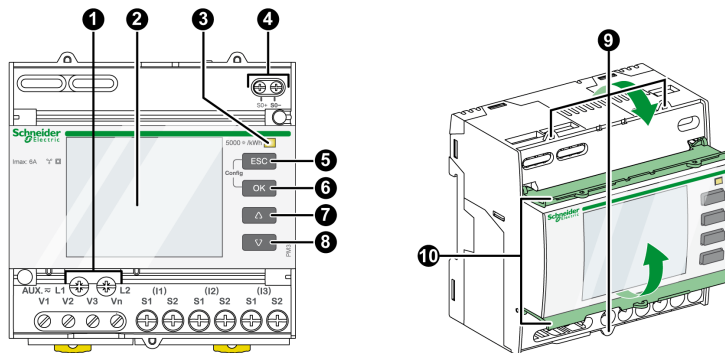

- 1 Control power
- 2 Display with white backlit
- 3 Flashing yellow meter indicator (used to check the accuracy)
- 4 Pulse output for remote transfer (PM3210)
- 5 **ESC** Cancellation
- 6 **OK** Confirmation
- 7 **▲** Up
- 8 **▼** Down
- 9 Sealing points (three)
- 10 Sealable covers

**PM3250 / PM3255**

The various features of the listed power meters are shown in the diagram below:

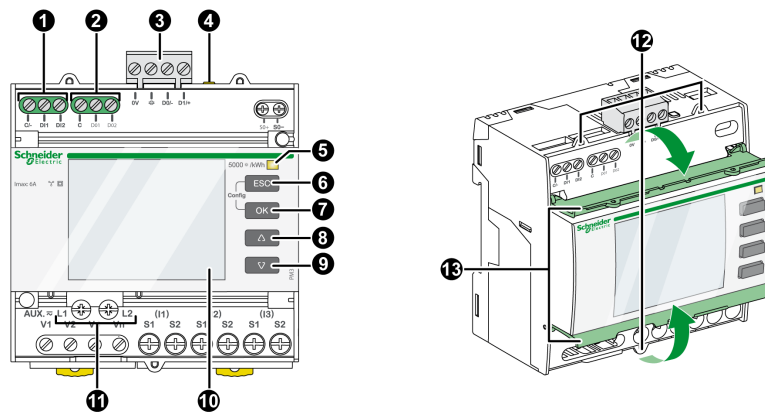

- 1 Digital inputs x 2 (PM3255)
- 2 Digital outputs x 2 (PM3255)
- 3 Communication port
- 4 Yellow indicator for communication diagnosis
- 5 Flashing yellow meter indicator (used to check the accuracy)
- 6 **ESC** Cancellation
- 7 **OK** Confirmation
- 8 **▲** Up
- 9 **▼** Down
- 10 Display with white backlit
- 11 Control power
- 12 Sealing points (three)
- 13 Sealable covers

---

## What Is in This Chapter?

This chapter contains the following topics:

Topic	Page
Safety Measures	14
Dimensions	15
DIN Rail Mounting and Dismantling	16
Connection	18

## Safety Measures

### Specific Hazard Associated with Power Meters

In the case of almost all electric and electronic devices, the device's power supply is the root cause of electrical hazards. The hazard can be eliminated by disconnecting the power supply.

Consequently, this connection must be broken before carrying out any kind of work on the product.

 <b>DANGER</b>
<b>RISK OF ELECTRIC SHOCK, EXPLOSION, OR ARC FLASH</b>
<ul style="list-style-type: none"><li>• Before carrying out work of any kind, disconnect connection wires. Disconnect all the power supplies running to the power meter and the equipment on which it is installed.</li><li>• Always use a correctly calibrated voltage tester to check that the power supply has been properly disconnected.</li></ul>
<b>Failure to follow these instructions will result in death or serious injury.</b>

### Other Safety Measures

Carefully read through the safety measures described below. You are always required to implement them fully before attempting to install, repair, or service electrical equipment.

 <b>DANGER</b>
<b>RISK OF ELECTRIC SHOCK, EXPLOSION, OR ARC FLASH</b>
<ul style="list-style-type: none"><li>• Wear suitable personal protective equipment and follow the currently applicable electrical safety instructions.</li><li>• This equipment may only be installed by qualified electricians who have read all the relevant information.</li><li>• NEVER work alone.</li><li>• Before performing visual inspections, tests, or maintenance on this equipment, disconnect all sources of electric power. Assume that all circuits are live until they have been completely de-energized, tested and tagged. Pay particular attention to the design of the power system. Consider all power supply sources, particularly the potential for backfeed.</li><li>• Before closing protective covers and doors, carefully inspect the work area to ensure that no tools or objects have been left inside the equipment.</li><li>• Take care when removing or replacing panels. Take special care to ensure that they do not come into contact with live busbars. To minimize the risk of injuries, do not tamper with the panels.</li><li>• The successful operation of this equipment depends upon proper handling, installation, and operation. Failure to follow basic installation procedures can lead to personal injury as well as damage to electrical equipment or other property.</li><li>• NEVER shunt an external fuse/circuit breaker.</li><li>• The power meters must be installed in a suitable electrical cabinet.</li></ul>
<b>Failure to follow these instructions will result in death or serious injury.</b>

## Dimensions

### Dimensions of PM3200 / PM3210

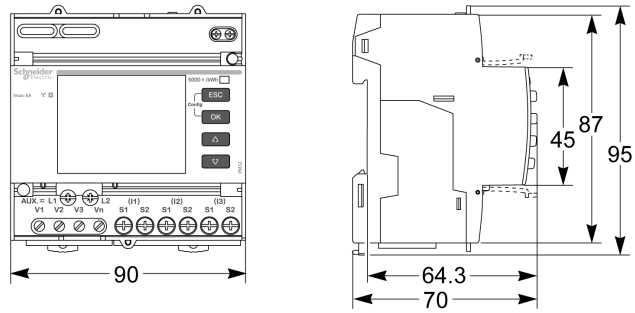

Unit: mm

### Dimensions of PM3250 / PM3255

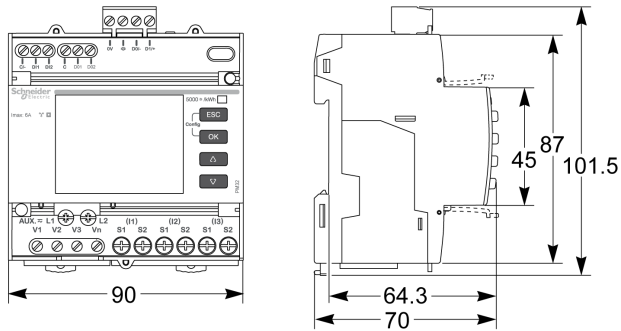

Unit: mm

## DIN Rail Mounting and Dismantling

### Presentation

You can install the power meter on a DIN rail. The device must not be tilted following installation. When mounting the device on, or dismantling it from, a DIN rail, you can keep the terminals wired up.

### DIN Rail Mounting

To install the power meter on a DIN rail, proceed as follows:

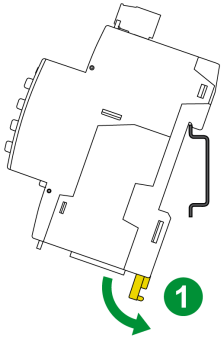
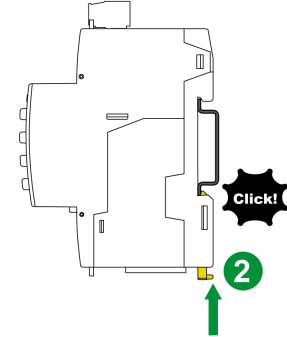
Step	Action
1	Position the 2 upper slots on the rear of the power meter on the DIN rail. 
2	Press the device against the DIN rail until the locking mechanism engages. The device is now attached to the rail. 



**Removal from a DIN rail**

To remove the power meter from a DIN rail, proceed as follows:

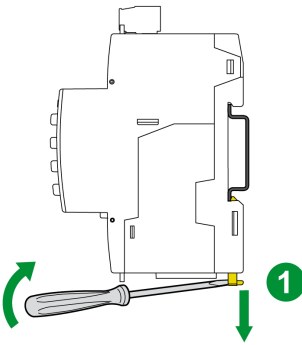
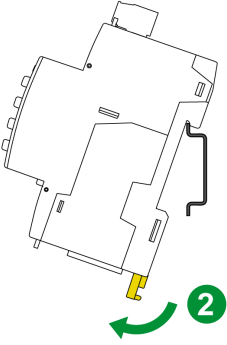
Step	Action
1	<p data-bbox="475 282 1220 331">Using a flat screwdriver (<math>\leq 6.5</math> mm), lower the locking mechanism to release the device.</p> 
2	<p data-bbox="475 741 1220 768">Lift the device up to free it from the DIN rail.</p> 

## Connection

### Overview

The diagrams below illustrate how to connect the power meters to a single-phase or three-phase 3- or 4-wire power system.

### Connection Diagram of PM3200 / PM3210

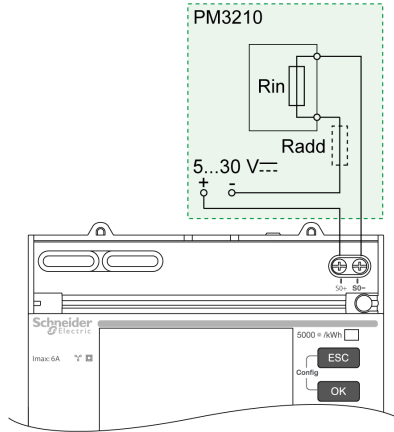

**NOTE:** The electrical wiring is explained in the table below.

- The pulse output is compatible with S0 format.
- The pulse output on the PM3210 indicates the primary consumption with consideration of transformer ratios.
- You can directly connect the pulse output on the PM3210 to a 24 V DC (< 30 V DC) input on a Zelio or Twido PLC.
- For other concentrators, if  $V_{DC}/R_{in} > 15 \text{ mA}$ , add a resistor  $R_{add} = (V_{DC}/0.01) - R_{in} \Omega$

### Connection Diagram of PM3250 / PM3255

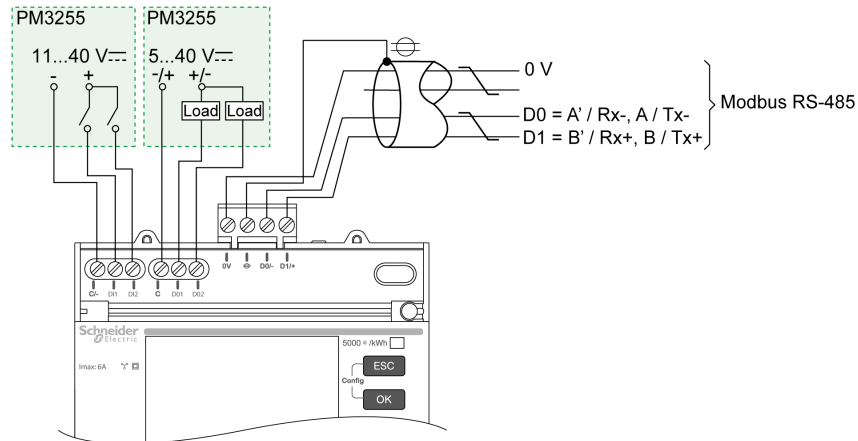

**NOTE:** The electrical wiring is explained in the table below.

- The digital outputs of PM3255 are polarity-independent.
- The digital inputs and outputs are electrically independent.

Power Supply

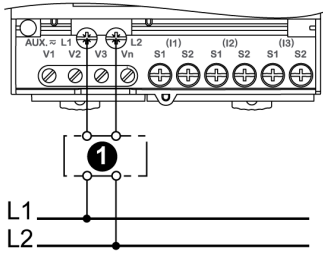
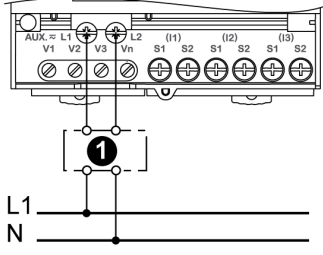
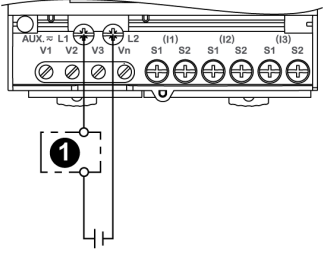
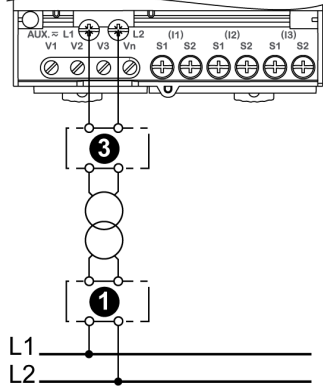
Power Supply	Power Meter Wiring
<p>173...480 V AC, 45...65 Hz</p>	
<p>100...277 V AC, 45...65 Hz</p>	
<p>100...300 V DC</p>	
<p>Control Power Transformer: 100...120 V AC Secondary, 50 VA max.</p>	

**Wiring on Single Phase Systems with CTs**

Power System	Power Meter Wiring
1PH2W L-N	
1PH2W L-L	
1PH3W L-L-N	
1PH4W multi L with N	<p>2 CTs</p> <p>3 CTs</p>

Wiring on Three-Phase Systems with CTs

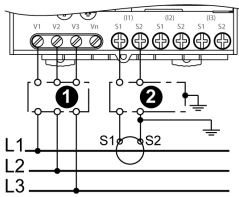
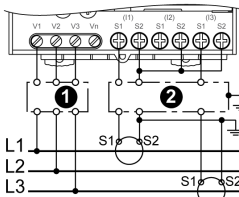
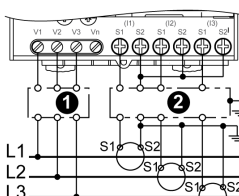
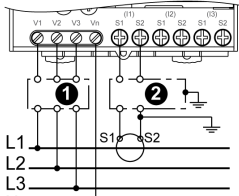
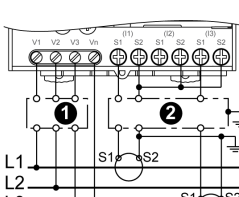
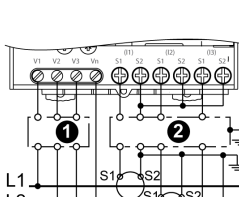
Power System	Power Meter Wiring
<p>3PH3W</p>	 <p>1 CT (balanced)</p>  <p>2 CTs</p>  <p>3 CTs</p>
<p>3PH4W</p>	 <p>1 CT (balanced)</p>  <p>2 CTs (for balanced 3-wire load)</p>  <p>3 CTs</p>

**Wiring on Three-Phase Systems with CTs and VTs**

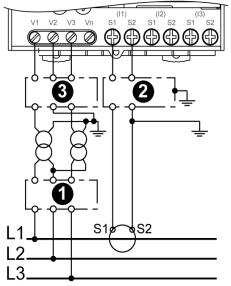
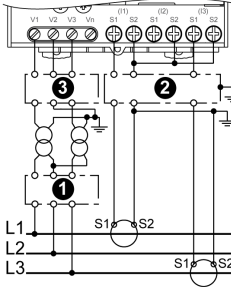
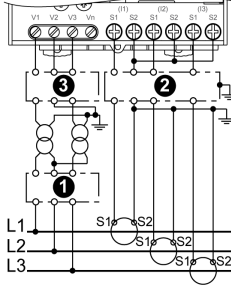
Power System	Power Meter Wiring
3PH3W	 <p data-bbox="627 566 858 595">2 VTs, 1 CT, (balanced)</p>  <p data-bbox="627 936 754 965">2 VTs, 2 CTs</p>  <p data-bbox="627 1310 754 1339">2 VTs, 3 CTs</p>

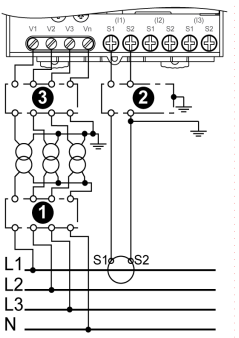
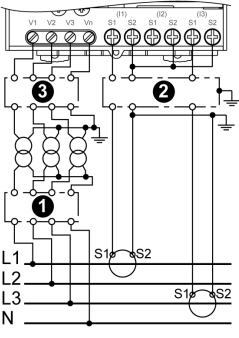
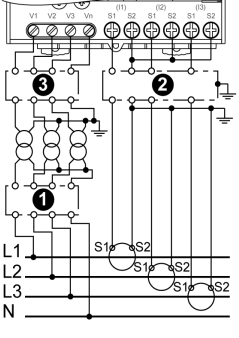
Power System	Power Meter Wiring
3PH4W	 <p data-bbox="614 560 853 593">3 VTs, 1 CTs, (balanced)</p>  <p data-bbox="614 952 981 985">3 VTs, 2 CTs, (for balanced 3-wire load)</p>  <p data-bbox="614 1344 742 1377">3 VTs, 3 CTs</p>

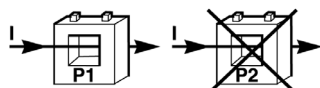

- 1 Protection containing a voltage disconnect switch with a fuse or disconnect circuit breaker (be adapted to suit the supplied voltage rating and the available short-circuit current at connection point, 250 mA for control power)
- 2 Shorting switch unit
- 3 A fuse or disconnect circuit breaker (be adapted to suit the supplied voltage rating and the available short-circuit current at the connection point, 250 mA for control power)





---

# Functions

# 3

---

## What Is in This Chapter?

This chapter contains the following topics:

Topic	Page
Metering	26
Alarms	31
Input/Output Capabilities	34
Multi-tariff	36
Data Logging (PM3255)	39

## Metering

The following table lists the topics related to metering functions:

<b>Contents</b>	<b>Page</b>
Power Meter Characteristics	<i>(see page 27)</i>
Real-Time Measuring	<i>(see page 27)</i>
Minimum/Maximum Values	<i>(see page 27)</i>
Demands Readings	<i>(see page 28)</i>
Energy Readings	<i>(see page 29)</i>
Power Quality Analysis Values	<i>(see page 29)</i>
Other Characteristics	<i>(see page 30)</i>

## Power Meter Characteristics

The power meter measures currents and voltages and reports in real time rms values for all 3-phases and neutral. In addition, the power meter calculates power factor, real power, reactive power, and more.

The following tables list the metering characteristics of the power meter. If the values are not specifically mentioned, you can obtain the values through HMI and communication.

## Real-Time Measuring

The following table lists the metering characteristics of the power meter for the real-time measurement:

Characteristics	Description
Current	Per phase, neutral, and average of 3 phases
Voltage	L-L, L-N, and average of 3 phases
Frequency	40...70 Hz
Active power	Total and per phase (signed)
Reactive power	Total and per phase (signed)
Apparent power	Total and per phase
Power factor (True)	Total and per phase 0.000 to 1 (signed) by HMI 0.000 to 2 (signed) by Communication
Tangent phi (Reactive factor)	Total
Current unbalance	Per phase, worst of 3 phases
Voltage unbalance	L-L, worst of 3 phases L-N, worst of 3 phases

## Minimum/Maximum Values

When any one-second real-time reading reaches its highest or lowest value, the power meter saves the values in its nonvolatile memory. These values are called the minimum and maximum (min./max.) values.

From the power meter display, you can:

- view all min./max. values since the last reset and the reset date and time.
- reset min./max. values.

All running min./max. values are arithmetic minimum and maximum values. For example, the minimum phase A-N voltage is the lowest value in the range from 0 to 1 MV that has occurred since last reset of the min./max. values.

The power meter provides time stamping for 6 important minimum/maximum values. Refer to register number 45130 to 45164 in the register list for details.

The following table lists the minimum and maximum values stored in the power meter:

Characteristics	Description
Current	Per phase, neutral, and average <sup>(1)</sup> Minimum: lowest of 3 phases <sup>(2)</sup> Maximum: highest of 3 phases <sup>(2)</sup>
Voltage	(L-L and L-N) per phase and average
Frequency	–
Active power	Per phase <sup>(1)</sup> and total
Reactive power	Per phase <sup>(1)</sup> and total
Apparent power	Per phase <sup>(1)</sup> and total
Power factor	Per phase <sup>(1)</sup> and total
Tangent phi (Reactive factor)	Total <sup>(1)</sup>
THD current (PM3210, PM3250, and PM3255)	Maximum: Per phase, neutral, and highest of 3 phase <sup>(2)</sup> Minimum: Per phase <sup>(1)</sup> and neutral <sup>(1)</sup>
THD voltage (PM3210, PM3250, and PM3255)	(L-L and L-N) per phase <sup>(1)</sup> Maximum: Highest of 3 phases <sup>(2)</sup> Minimum.: Lowest of 3 phases <sup>(2)</sup>
<sup>(1)</sup> Available only by communication	
<sup>(2)</sup> Available only by HMI	

**Demand Readings**

The power meter provides a variety of demand readings.

Characteristics	Description
Current	Per phase, neutral, and average <sup>(1)</sup>
Active, reactive, apparent power	Total
Peak Demand Values (PM3210, PM3250, and PM3255)	
Current	Per phase, neutral, and average <sup>(1)</sup>
Active, reactive, apparent power	Total
<sup>(1)</sup> Available only by communication	

**Demand Calculation Methods**

Power demand is the energy accumulated during a specified period divided by the length of the period. Current demand is calculated using arithmetical integration of the current rms values during a period of time, divided by the length of the period. How the power meter performs this calculation depends on the selected method. To be compatible with electric utility billing practices, the power meter provides the block interval power/current demand calculations. The default demand calculation is set to a fixed block with a 15 minutes interval.

In the block interval demand method, select a block of time that the power meter uses for the demand calculation. You can choose how the power meter handles the block of time (interval). 2 different modes are possible:

- Fixed block - Select an interval from 1 to 60 minutes (in 1 minute increments). The power meter calculates and updates the demand at the end of each interval.
- Sliding block - Select an interval from 1 to 60 minutes (in 1 minute increments). For demand intervals less than 15 minutes, the value is updated every 15 seconds. For demand intervals of 15 minutes and greater, the demand value is updated every 60 seconds. The power meter displays the demand value for the last completed interval.

The following figures illustrate the 2 ways to calculate demand power using the block method. For illustration purposes, the interval is set to 15 minutes.

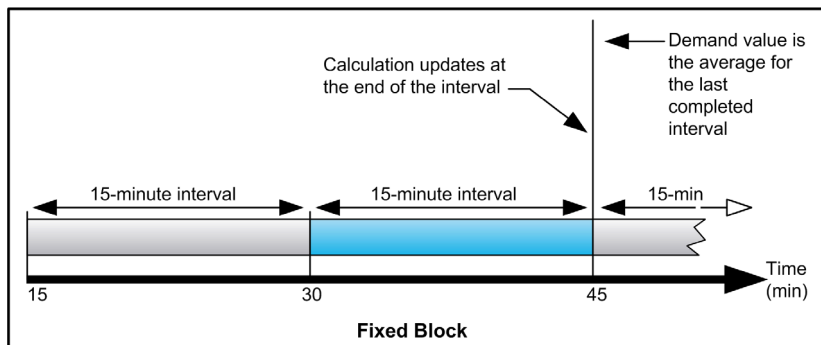
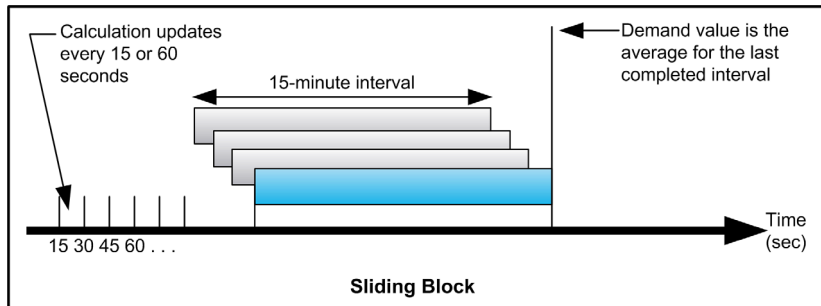

**Peak Demand**

In nonvolatile memory, the power meter maintains a maximum operating demand values called peak demand. The peak is the highest value (absolute value) for each of these readings since the last reset.

You can reset peak demand values from the power meter display. You should reset peak demand after changes to basic power meter setup such as CT ratio or power system configuration.

## Energy Readings

The power meter calculates and stores total and partial energy values for active, reactive, and apparent energy.

You can view energy values from the display. The resolution of the energy value automatically changes from kWh to MWh (kVAh to MVARh).

The energy values automatically resets to 0 when it reaches the limit of  $1 \times 10^6$  MWh,  $1 \times 10^6$  MVAh, or  $1 \times 10^6$  MVARh. Manual reset of total energy is not allowed. You can reset the partial energies including partial energy import, energy by tariff, and phase energy manually on HMI.

Energy values can be reported over communications as 64-bit signed integers. The units are always Wh, VARh, or VAh.

The following table lists the energy readings from the power meter:

Characteristics	Description
Energy Values (Import)	
Active energy	Total and per phase, partial, by tariff 0 to $1 \times 10^{12}$ Wh Auto reset to 0 in case of over limit
Reactive energy	Total and per phase, partial 0 to $1 \times 10^{12}$ VARh Auto reset to 0 in case of over limit
Apparent energy	Total and per phase, partial 0 to $1 \times 10^{12}$ VAh Auto reset to 0 in case of over limit
Energy Values (Export)	
Active energy	Total 0 to $1 \times 10^{12}$ Wh Auto reset to 0 in case of over limit
Reactive energy	Total 0 to $1 \times 10^{12}$ VARh Auto reset to 0 in case of over limit
Apparent energy	Total 0 to $1 \times 10^{12}$ VAh Auto reset to 0 in case of over limit

## Power Quality Analysis Values

The power quality analysis values use the following abbreviations:

- HC (Harmonic Content) =  $\sqrt{(H_2^2 + H_3^2 + H_4^2 + \dots)}$
- H1 = Fundamental Content
- THD (Total Harmonic Distortion) =  $HC/H1 \times 100\%$

THD is the power analysis value and a quick measure of the total distortion present in a waveform. THD is the ratio of harmonic content to the fundamental and provides a general indication of the quality of a waveform. THD is calculated for both voltage and current.

The following table lists the power quality values of the power meter

Characteristics	Description
Power Quality Values (PM3210, PM3250, and PM3255)	
Total harmonic distortion (THD)	Per phase current and per phase voltage (L-L and L-N) Worst of 3 phases Average of 3 phases <sup>(1)</sup>
<sup>(1)</sup> Available only by communication	

**Other Characteristics**

The following table lists other characteristics of the power meter:

<b>Characteristics</b>	<b>Description</b>
<b>Reset</b>	
Epart	Per phase, partial, by tariff energy values
Minimum and maximum values	–
Peak demand values	–
<b>Local or Remote Setup</b>	
Distribution system type	Three-phase 3- or 4-wire with 1, 2, or 3 CTs, single-phase 2- or 3-wire with 1 or 2 CTs, with or without VTs
Current transformers rating	Primary 5 to 32,767 A Secondary 5 A, 1 A
Voltage transformers rating	Primary 1,000,000 Vmax Secondary 100, 110, 115, 120
Current demand calculation method	1 to 60 minutes
Power demand calculation method	1 to 60 minutes

## Alarms

The following table lists the topics related to alarms:

<b>Contents</b>	<b>Page</b>
Overview	<i>(see page 32)</i>
Alarms Configuration	<i>(see page 32)</i>
View Alarm Status on HMI	<i>(see page 33)</i>
Alarm Activity and History	<i>(see page 33)</i>
Using an Alarm to Control a Digital Output	<i>(see page 33)</i>

**Overview**

The power meter provides setpoints driven alarms. The alarms include:

Alarms	PM3210, PM3250	PM3255
<b>Standard Alarms</b>		
Over Current, Phase	√	√
Under Current, Phase	–	√
Over Voltage, L-L	–	√
Under Voltage, L-L	√	√
Over Voltage, L-N	–	√
Under Voltage, L-N	√	√
Over Power, Total Active	√	√
Over Power, Total Reactive	–	√
Over Power, Total Apparent	√	√
Leading Power Factor, Total	–	√
Lagging Power Factor, Total	–	√
Over Demand, Total Active Power, Present	–	√
Over Demand, Total Apparent Power, Present	–	√
Over THD-U, Phase	–	√
Under Power, Total Active	√	√
Over THD-I, Phase	–	√
Over THD-V, Phase	–	√
<b>Customized Alarms</b>		
Over Energy, Total Active	–	√

**Alarms Configuration**

For the standard alarms, you must configure the following features by using HMI or communication:

- Pickup setpoint
- Trigger delay (Pickup/Dropout delay)
- Dropout setpoint (Deviation percentage from pickup setpoint)

Among the standard alarms, dropout setpoint and trigger delay are common features of all the alarms. Pickup setpoint is identical for each alarm.

For more information on power meter handling the setpoint-driven alarms, refer to the figure below.

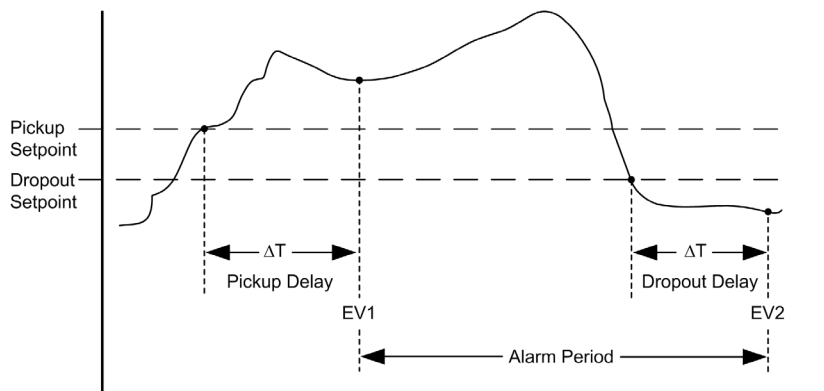

**EV1** An alarm is active. The power meter records the date, time, and value at EV1 when the pickup setpoint and time delay are satisfied. The power meter performs any tasks assigned to the event such as operation of a digital output, backlight flashing, and alarm symbol flashing.

**EV2** An alarm is inactive when the dropout setpoint and time delay are satisfied. The power meter performs any tasks assigned to the event such as switch off a digital output, backlight, and alarm symbol stop flashing.

**NOTE:** The time delay is satisfied only if during the delay, the actual value does not fall between the pickup setpoint and dropout setpoint.

For the over energy alarm, you also need to configure the method, which refers to the energy accumulation and detection period.



The 3 options are:

- Day method: the energy accumulation starts at 8:03 A.M. every day and clears up at 8:03 A.M. the next day.
- Week method: the energy accumulation starts at 8:03 A.M. every Sunday and clears up at 8:03 A.M. the next Sunday.
- Month method: the energy accumulation starts at 8:03 A.M. on the first day of the month and clears up at 8:03 A.M. on the first day of the next month.

When the accumulated energy pickup setpoint and time delay are satisfied, the alarm is active. When the accumulated energy dropout setpoint and time delay are satisfied, the alarm is inactive.

### View Alarm Status on HMI

The alarm status summary page includes the following items:

- Tot Enable: displays total number of the alarms enabled by the user in the alarm configuration.
- Tot Active: displays total number of the active alarms. One active alarm with several entries is considered as one.

For example, over current at phase 1 creates the first entry, over current at phase 2 creates the second entry, but the total number of the active alarms is one.

- Output: refers to the association with digital output (DO).

The alarm level 2 pages list the number of entries of the active and logged alarms.

The logged alarm entries include the active alarms and the historic alarms. One alarm occurred several times can create several active or logged entries.

The alarm level 3 page lists the detailed information of each active/log entry. When an active alarm is not present and you enter the log entry list, it considers that you have acknowledged all the logged alarms.

### Alarm Activity and History

The active alarm list holds 20 entries at a time. The list works as a circular buffer, replacing old entries with new entries. The information in the active alarm list is volatile. When the power meter resets, this list is reinitialized.

The alarm history log holds 20 entries of alarms that have disappeared. The log also works as a circular buffer, replacing old entries with new entries. This information is nonvolatile.

### Using an Alarm to Control a Digital Output

You can configure digital outputs as alarms. Refer to Input/Output Capabilities (*see page 34*) for more information.

## Input/Output Capabilities

The following table lists the topics related to input/output capabilities:

<b>Contents</b>	<b>Page</b>
Digital Inputs (PM3255)	<i>(see page 35)</i>
Pulse Output (PM3210)	<i>(see page 35)</i>
Digital Outputs (PM3255)	<i>(see page 35)</i>

### Digital Inputs (PM3255)

The power meter can accept 2 digital inputs designated as DI1 and DI2.

The digital inputs have 4 operating modes:

- Normal Input Status: use for simple ON/OFF digital inputs. The digital inputs can be OF or SD signals of a circuit breaker.
- Multi-tariff Control: you can control tariff either through communication, the internal clock or by 1 or 2 tariff inputs. Tariff control through the tariff inputs is performed by applying a proper combination of ON or OFF signal to the inputs. Each combination of ON or OFF signal results in the power meter registering the energy in a particular tariff register. Refer to the table below for input coding.
- Input Metering: you can configure the meter in input metering modes to collect the pulses for WAGES application. To activate this function, set the input metering pulse frequency (pulse/unit). The meter counts the number of pulses and calculates the number of unit. Pulse width or pulse stop less than 10 milliseconds is invalid for pulse counting.
- Energy Reset: energy reset function resets partial energy, energy by tariff, and energy by phase. Reset is activated by an ON signal lasting for over 10 milliseconds.

The following table describes the input coding in binary format:

Input Voltage	Active Tariff
Meter with 4 tariffs:	
DI1/DI2 = OFF/OFF	Tariff 1 active
DI1/DI2 = OFF/ON	Tariff 2 active
DI1/DI2 = ON/OFF	Tariff 3 active
DI1/DI2 = ON/ON	Tariff 4 active
Meter with 2 tariffs (always associated with DI1, and DI2 can be left floating or configured as other mode):	
DI1 = OFF	Tariff 1 active
DI1 = ON	Tariff 2 active

### Pulse Output (PM3210)

Pulse output is used for active energy pulse output only. You can configure the pulse frequency (pulse/kWh) and the pulse width. The minimum pulse width is 50 ms. The pulse stop is equal or longer than the pulse width. The pulse output indicates the primary energy consumption considering transformer ratios. You should set a proper value of pulse frequency and pulse width to avoid pulse missing due to over-counting.

### Digital Outputs (PM3255)

The power meter has 2 solid state relay outputs (DO1 and DO2). The relay outputs have 3 operation modes:

- Alarm: the output is controlled by the power meter in response to an alarm condition. The output turns On (relay closed) when at least one alarm is active. The output turns Off (relay open) when the alarm is deactivated.
- Energy Output: you can use DO1 only for active energy pulse output and DO2 only for reactive energy pulse output. You can configure the pulse frequency (pulse/kWh or pulse/kVARh) and the pulse width.
- Disable: the digital output function is disabled.

## Multi-tariff

The following table lists the topics related to multi-tariff:

<b>Contents</b>	<b>Page</b>
Presentation	<i>(see page 37)</i>
DI Control Mode (PM3255)	<i>(see page 37)</i>
Communication Control Mode (PM3250, PM3255)	<i>(see page 37)</i>
RTC Control Mode	<i>(see page 37)</i>

## Presentation

The power meter provides multi-tariff energy accumulation. It supports up to 4 tariffs.

The tariff switching has the following 3 kinds of control modes:

- Digital input
- Communication
- Internal RTC

You can configure the control mode by using HMI (all the 3 modes) or by using communication (not for RTC).

Command number 2060 is used to configure the control mode by communication. Refer to Modbus communication (*see page 61*) for more details.

The following table presents the rules to change multi-tariff control mode by Modbus command:

From	To
Disable	<ul style="list-style-type: none"> <li>• Communication</li> <li>• Digital input</li> </ul>
RTC	Communication
Communication	Disable

## DI Control Mode (PM3255)

In the DI control mode, the tariff switching is triggered by the change in input status of DI. Refer to Digital inputs (*see page 35*) for more details.

**NOTE:** If you change DI mode to other operation modes (normal input status, input metering, or energy reset) while multi-tariff control mode is in DI control mode, the multi-tariff function is automatically disabled.

**NOTE:** If you change multi-tariff control mode to other control modes (communication or internal RTC) while DI is configured for multi-tariff function, the DI operation mode automatically changes to normal input status.

## Communication Control Mode (PM3250, PM3255)

In the communication control mode, the tariff switching is triggered by command number 2008. Refer to Modbus communication (*see page 61*) for more details.

## RTC Control Mode

In RTC control mode, the tariff switching is triggered by the real time clock.

You can configure RTC control mode by using HMI. The configuration includes the selection of schedule mode and the setup of 1 or 2 schedulers depending on the schedule modes.

The 2 schedule modes for RTC trigger are:

- Day mode: weekdays and weekend share the same peak and peak-off duration and only 1 scheduler should be set.
- Week mode: the tariff management of weekdays and weekends are controlled separately. Hence, 2 schedulers should be set.

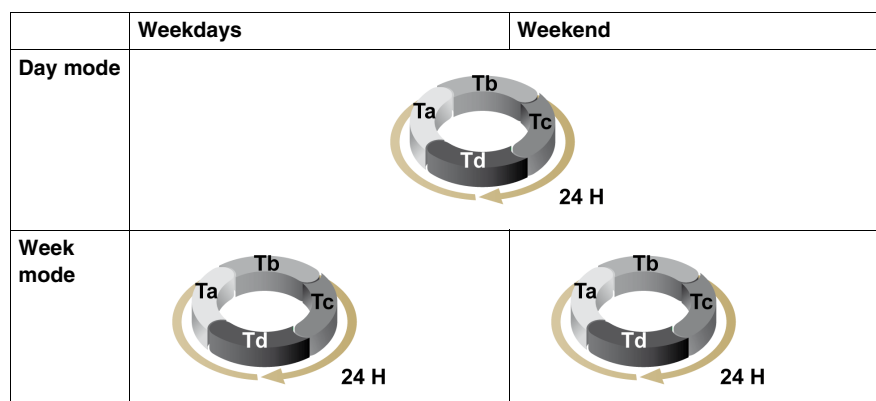

A scheduler supports maximum 4 time segments (Ta, Tb, Tc, and Td) for maximum 4 tariffs (T1, T2, T3, and T4). You can assign Ta, Tb, Tc, or Td to any tariff provided that any adjacent time segment has different tariff. A valid scheduler should always start from Ta segment and skipping the intermediate segment is not allowed.

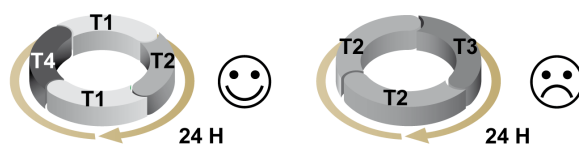

In the setup of a scheduler, you should define the tariff switching time and the target tariff rate from the switching time. In the application, when the set switching time reaches, the current tariff rate switches to the target rate automatically.

## Data Logging (PM3255)

The following table lists the topics related to data logging:

<b>Contents</b>	<b>Page</b>
Power Demand Log	<i>(see page 40)</i>
Special Notes for Power Demand Log	<i>(see page 40)</i>
Energy Log	<i>(see page 40)</i>
Special Notes for Energy Log	<i>(see page 40)</i>

The power meter provides power demand log and energy log. It stores all these logs in nonvolatile memory of the power meter. Power demand log and energy day log can be read as a log file. The 3 types of energy log can be read as registers.

The following table lists the maximum number of entries of each log:

<b>Log Type</b>	<b>Max. Entries Stored</b>
Power demand log	4608
Energy log (Daily)	45
Energy log (Weekly)	30
Energy log (Monthly)	13

**Power Demand Log**

Total active power demand value is logged. You can configure the power demand log only on HMI by enabling the function and selecting the log interval. The interval options include 10 minutes, 15 minutes, 20 minutes, 30 minutes, and 60 minutes. The maximum number of power demand log is 4608, which is equivalent to maximum 32 days for 10 minutes log interval or maximum 192 days for 60 minutes log interval. Each entry includes log time (4 registers) and log data (2 registers) and the total number of register is  $4608 \times 6 = 27648$ .

The demand log entry structure is shown in the following table:

<b>Log Entry</b>	Log date/time 4 Registers	Demand value 2 Registers
------------------	------------------------------	-----------------------------

The demand log file is circular. If the number of log days exceeds the maximum, it overwrites the log data of the oldest day.

**NOTE:** The overwriting unit is day, not entry. This means if overwriting happens, it erases the entire log of the oldest day along with the oldest entry.

With ION Enterprise, you can view and save the power demand log file to a disk.

**Special Notes for Power Demand Log**

- If date/time is not set by the user after date/time resets due to previous power interruption or the inoperable RTC (diagnosis code #205 or #207 is reported), new entries are not generated in the demand log.
- If you change date/time, all logged entries with log date/time after the new date/time are erased. For example, some entries were logged in October 20, 2012, if you change the date of the meter to October 19, 2012 by mistake, the entries of October 20, 2012 are erased.
- If you change the log interval option, the demand log system is reset and all logged entries are erased.

**Energy Log**

The meter also has the log for accumulated active energy.

The energy log entry structure is shown in the following table:

<b>Log Entry</b>	Log date/time 4 Registers	Energy value 4 Registers
------------------	------------------------------	-----------------------------

The 3 log types are:

- Day: the log interval is 1 day. The logging occurs at 8:03 A.M. every day and the accumulated active energy for the previous 24 hours is logged.
- Week: the log interval is 1 week. The logging occurs at 8:03 A.M. every Sunday and the accumulated active energy for the previous week is logged.
- Month: the log interval is 1 month. The logging occurs at 8:03 A.M. on the first day of each month and the accumulated active energy for the previous month is logged.

You can configure the energy log only by HMI. The day log, week log, and month log are enabled or disabled together during the configuration. However, the energy accumulation always starts from the fixed log time instead of the time of log enabled.

With ION Enterprise, you can view and save the energy day log file to a disk. You can also access day log, week log, and month log by reading the registers.

**Special Notes for Energy Log**

- If the date/time is not set by the user after the date/time resets due to previous power interruption, energy keeps accumulating. After the date/time is set and the log time is reached, all the accumulated energy is written into the log.
- If you reset the date, the logged entries with log date after the reset date are not erased.
- When the log time is reached, the meter checks the enable/disable status of the energy log. The meter logs the accumulated energy if the status is enable and discards if the status is disable. The accumulated energy resets to 0.
- The energy log is circular. If the number of the log entries exceeds the maximum, the oldest log entries are overwritten.



---

## What Is in This Chapter?

This chapter contains the following topics:

Topic	Page
Presentation	42
Configuration Mode	43
Modifying Parameters	49
Clock Setting	50
Display Mode	51
Full Screen Mode	59

## Presentation

### Introduction

The power meter features a sophisticated and intuitive human machine interface (HMI) with signaling LEDs, a graphic display, and contextual menu buttons for accessing the information required to operate the power meter and modify parameter settings.

The **Navigation** menu allows to display, configure, and reset parameters.

### General Display

The general display of the power meters is shown in the following picture:

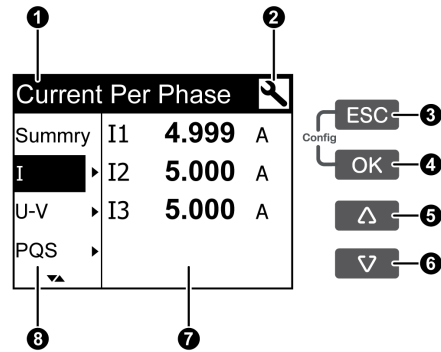

- 1 Main title
- 2 Configuration mode
- 3 Cancellation
- 4 Confirmation
- 5 Up
- 6 Down
- 7 Values/Parameters
- 8 Sub menu

### Status Information

The display and the LED on the power meters indicate the device current status.

LED Indicator	Description
5000 flashes / kWh	
OFF	Off/ no counting
Flashing	On, with counting
ON	Over counting due to wrong configuration or overload

The backlight and diagnosis/alarm indicate the device status.

Backlight	Diagnosis/Alarm	Description
OFF	-	Off
ON/Dimness	OFF	LCD is in power saving mode
ON/Normal	OFF	Normal working status
Flashing	Flashing	Alarm/Diagnosis is active
ON/Dimness	Flashing	Alarm/Diagnosis is active for 3 hours and LCD is in power saving mode
ON/Normal / ON/Dimness	ON	Not active alarm. Logged alarms are not acknowledged by the user

## Configuration Mode

### Settings for all Power Meters

The following settings have to be configured in configuration mode:

Function	PM3200	PM3210	PM3250	PM3255
Wiring	√	√	√	√
CT and VT Ratio	√	√	√	√
Nominal frequency	√	√	√	√
Date/Time	√	√	√	√
Multi-tariffs	√	√	√	√
Demand	√	√	√	√
Log	–	–	–	√
Digital Outputs	–	–	–	√
Digital Inputs	–	–	–	√
Pulse Output	–	√	–	–
Communication	–	–	√	√
Password (High and Low)	√	√	√	√
Alarms	–	√	√	√
HMI	√	√	√	√
Language	√	√	√	√

The default factory settings are listed in the following table:

Function	Factory settings
Wiring	3PH4W; VT Direction connection; 3 CTs on I1, I2, and I3
CT Ratio	CT Secondary = 5 A; CT Primary = 5 A
VT Ratio	NA
Nominal Frequency	50 Hz
Nominal Phase Order	A-B-C
Date/Time	1-Jan-2000/00:00:00
Multi-tariffs	Disable
Demand	Method: Sliding Block; Interval: 15 minutes
Power Demand Log	Disable
Energy Log	Disable
Digital Outputs	Disable
Digital Inputs	Input status
Pulse Output	100 pulse/kWh, pulse width: 100 millisecond
Communication	Baud Rate = 19 200; Parity = EVEN; Address = 1
Password	High: 0010; Low: 0000
Alarms	Disable
HMI LCD	Backlight: 4; Contrast: 5
HMI Mode	Full screen: Enable; Auto scroll: Disable
Language	English

**Enter the Configuration Mode**

The diagram below illustrates the various elements for operating the power meters:

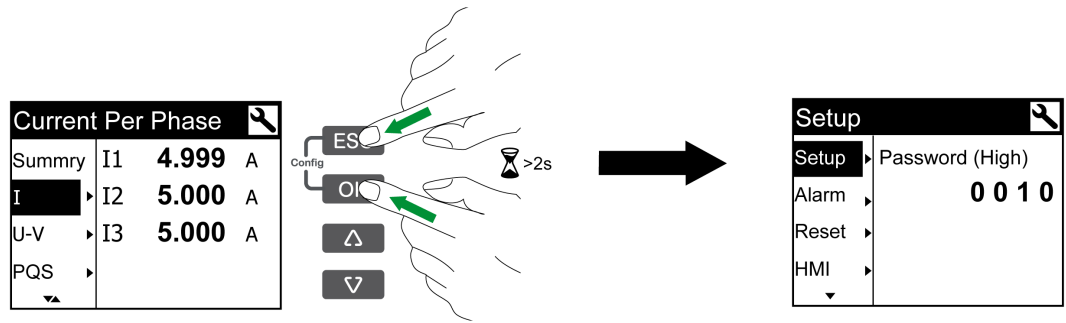

**▲** or **▼** Selection button to change or select parameter values

**OK** Confirmation button

**ESC** Cancellation button

To enter the configuration mode, hold **OK** and **ESC** for 2 seconds.

The following figures describe in details the configuration navigation, refer to Modifying Parameters (see page 49) to change the default selection.

**Configuration Mode Menu Tree for PM3200**

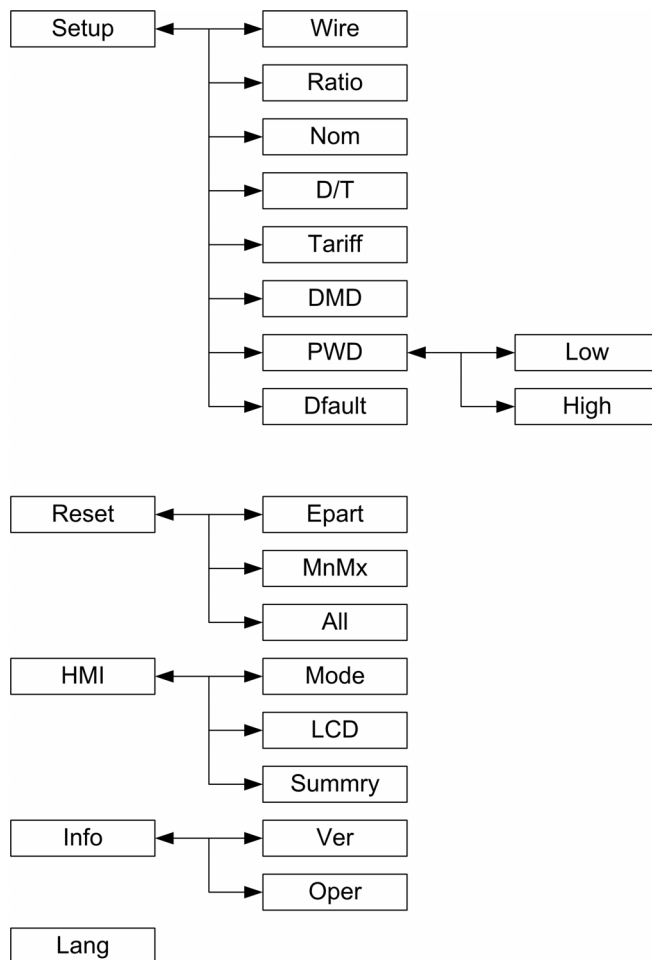

Configuration Mode Menu Tree for PM3210

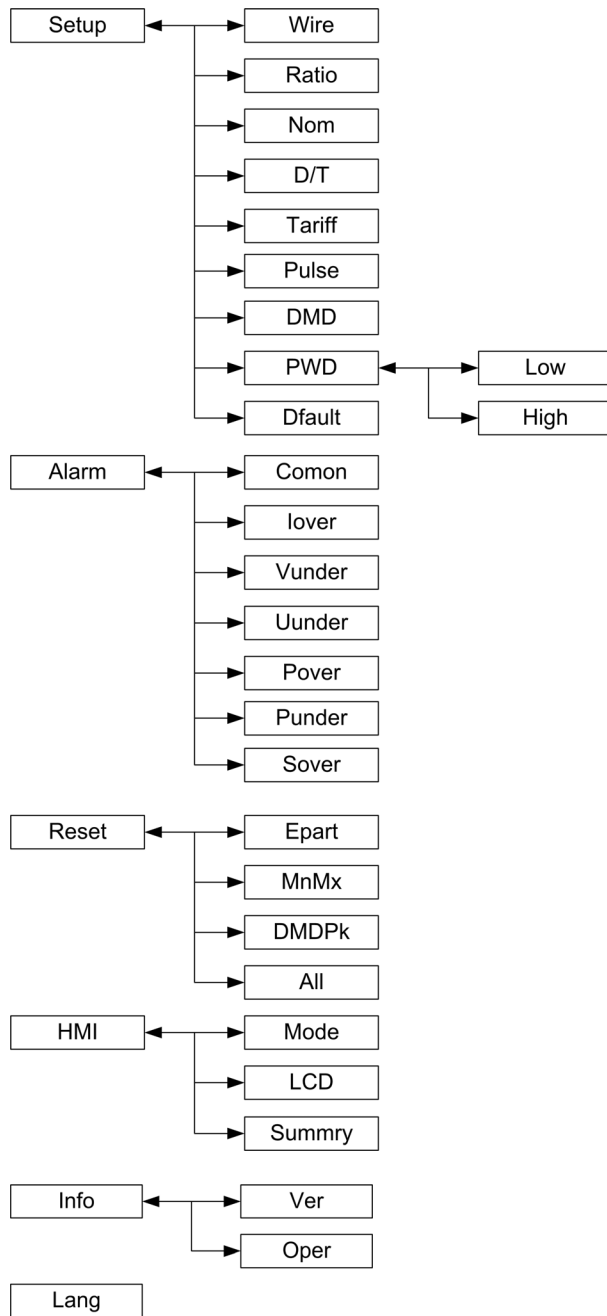

Configuration Mode Menu Tree for PM3250

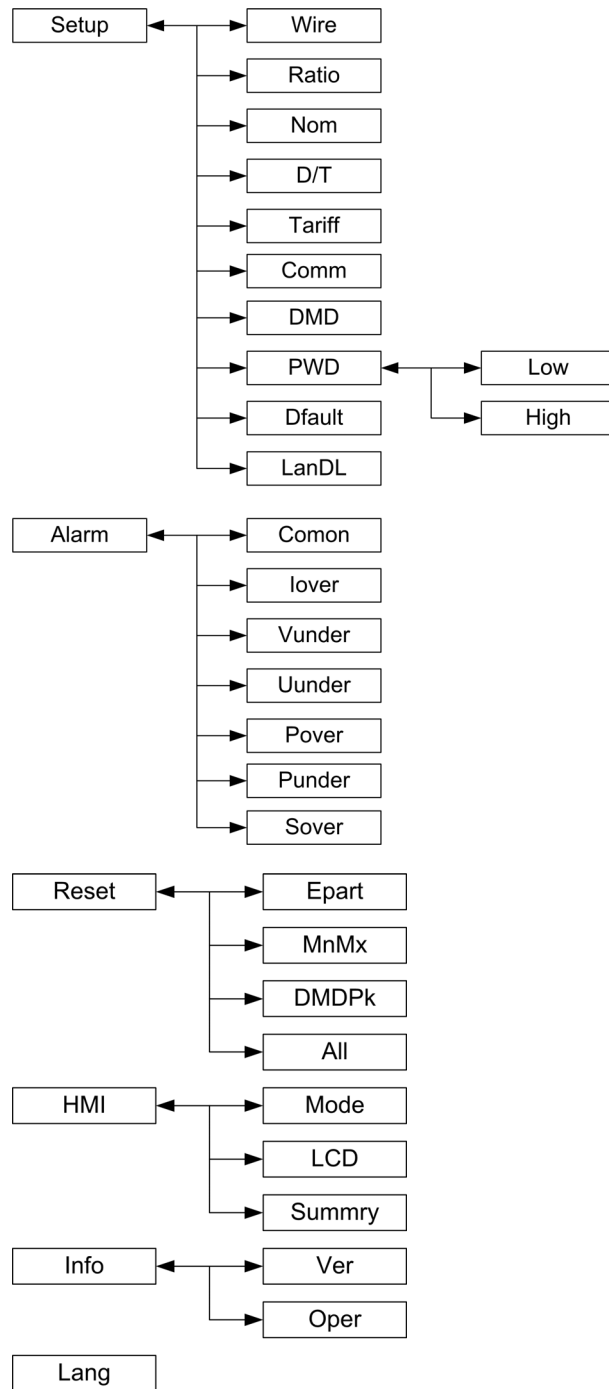

## Configuration Mode Menu Tree for PM3255

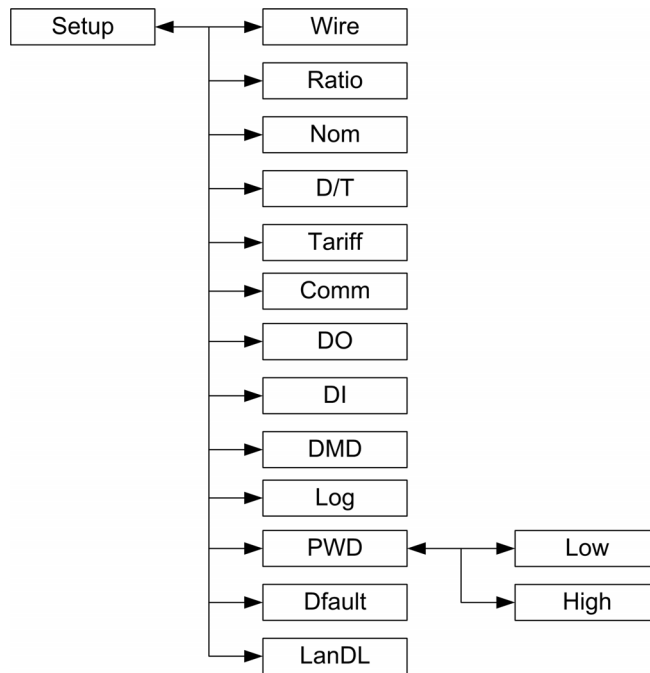

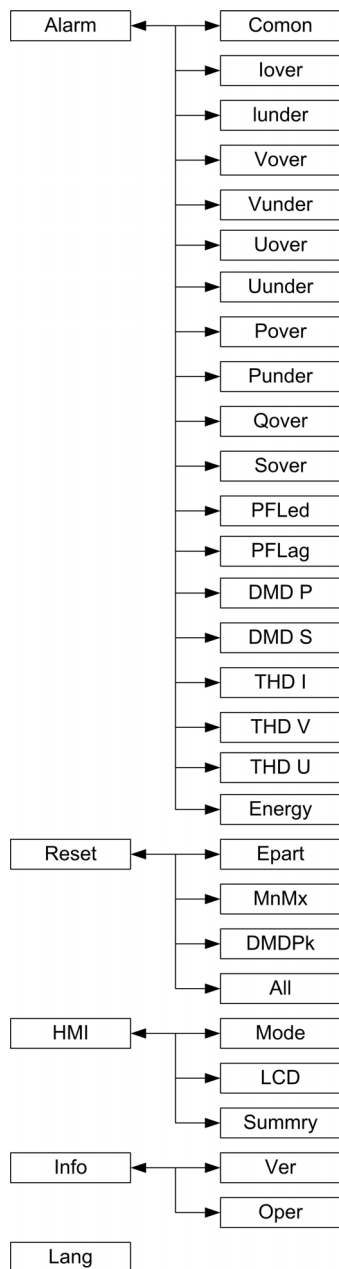



## Modifying Parameters

### Presentation

To modify any of the values, you must be thoroughly familiar with how the interface menus are structured and the general navigation principles. For more information about how the menus are structured, refer to menu trees of each power meter model (*see page 43*).

To modify the value of a parameter, follow either of the 2 methods described below:



- selecting an item in a list,
- modifying a numerical value, digit by digit.

The parameters listed below are the only ones which the numerical value can be modified:

- Date
- Time
- Voltage Transformer (VT) Primary
- Current Transformer (CT) Primary
- Password
- Modbus address of the power meter
- Pickup Setpoint
- Dropout Setpoint
- Time delay/Interval duration

### Selecting the Value in a List



The following table explains how to select a value in a list:

Step	Action
1	Use the  or  button to scroll through the parameter values until you reach the desired value.
2	Press  to confirm the new parameter value.

### Modifying the Numerical Value

The numerical value of a parameter is made up of digits. The digit on the far right side is selected by default (except for Date/Time).

To modify a numerical value, use the contextual menu buttons as described below:

Step	Action
1	Use the  or  button to modify the selected digit.
2	Press  to confirm the new parameter value.

### Aborting an Entry

To abort the current parameter entry, press the  button. The screen reverts to the previous display.

## Clock Setting

### Description

The time must be set when switching from winter to summer time.

The power meter automatically displays the screen to set **Date and Time** in case of loss of date and time when the power is interrupted for longer than 5 minutes.

The power meter retains the date and time settings before the interruption.

### Setting

To set the date and time, refer to procedure for modifying a numerical value (see page 49).

### Date/Time Format

The date is displayed in the format: DD-MMM-YYYY.

The time is displayed using the 24-hour clock in the format: hh:mm:ss.

### Clock Setting Menu

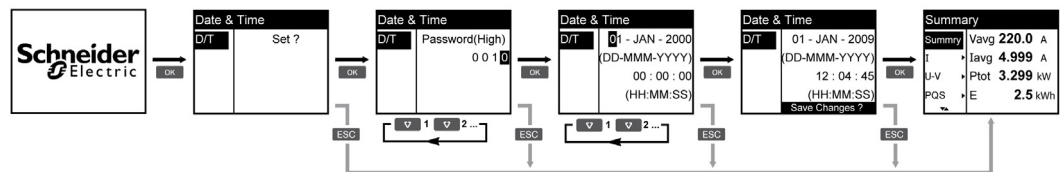

**NOTE:** Clock is set only after the date/time is reset due to power interruption.

## Display Mode

### Enter the Display Mode

If Full Screen mode is enabled, press any key to switch from Full Screen mode to Display mode.



If Full Screen mode is disabled, press **ESC** to switch from Configuration mode (**Setup** page) to Display mode.

### Display Mode Menu Tree for PM3200

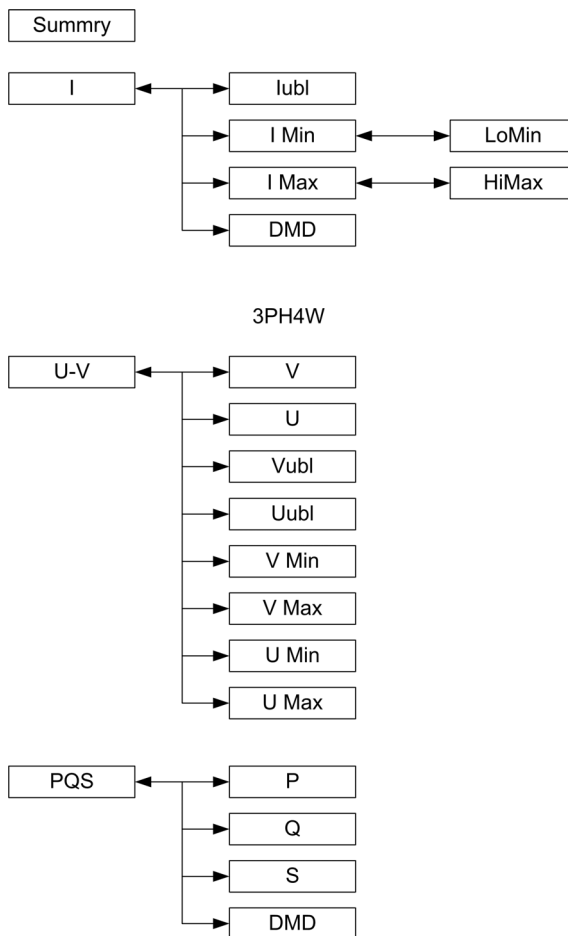

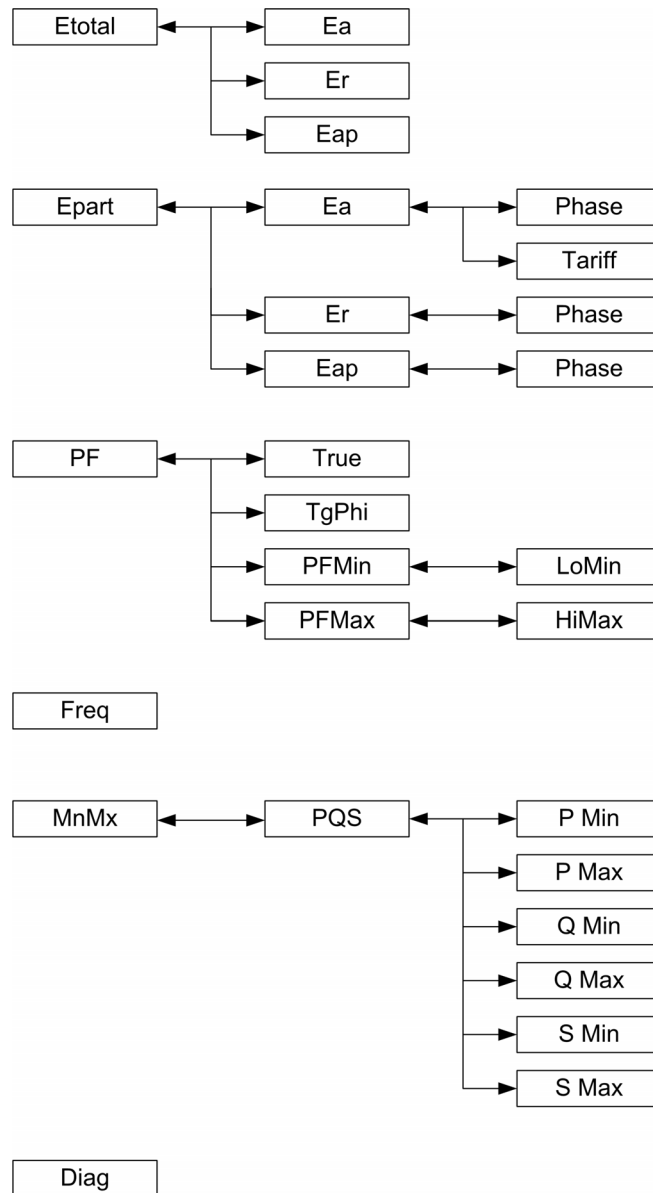

Display Mode Menu Tree for PM3210

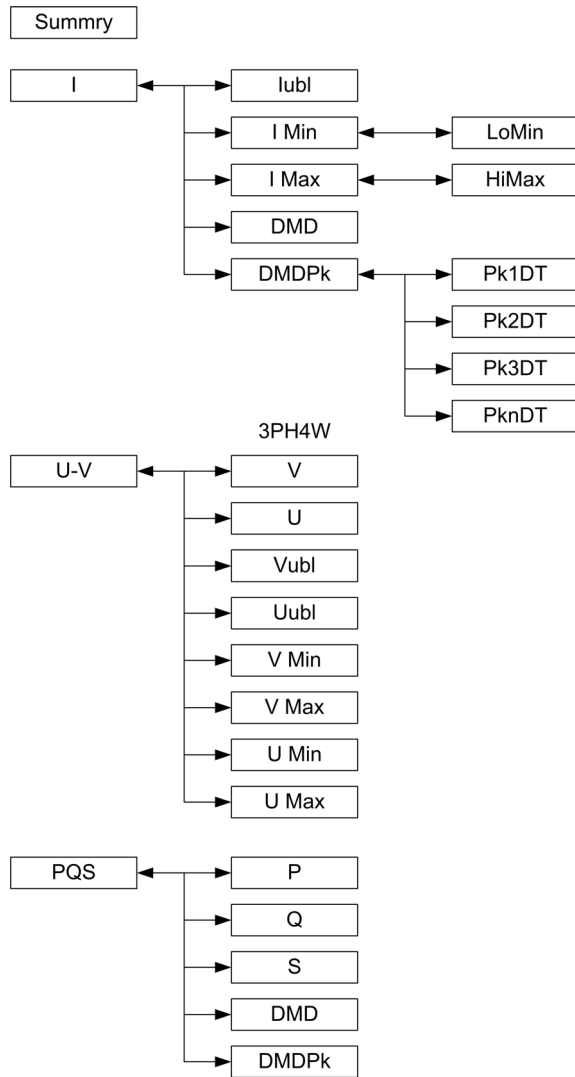

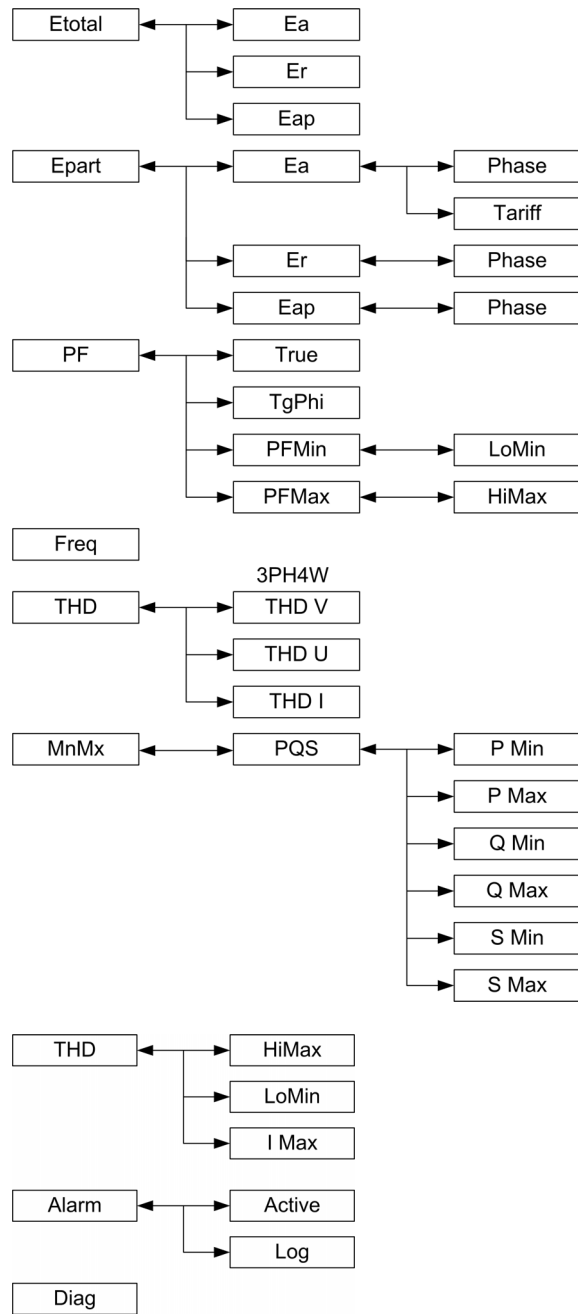

Display Mode Menu Tree for PM3250

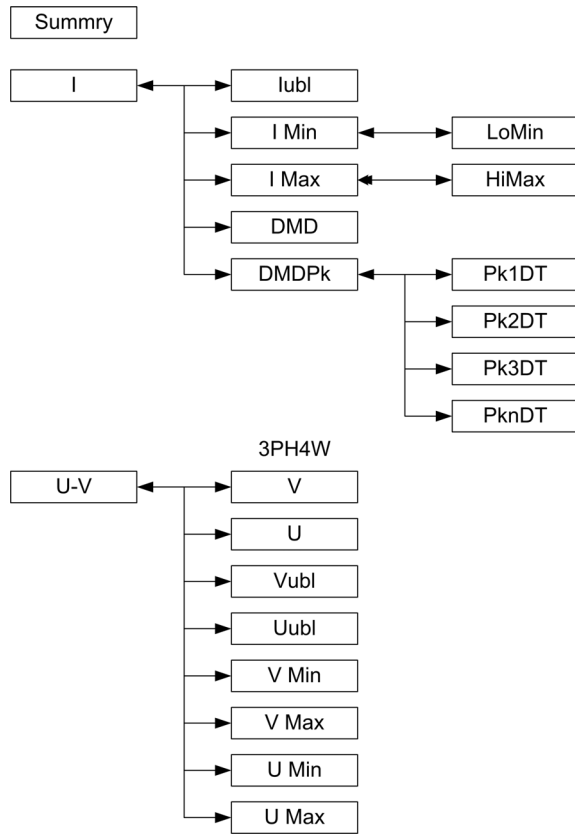

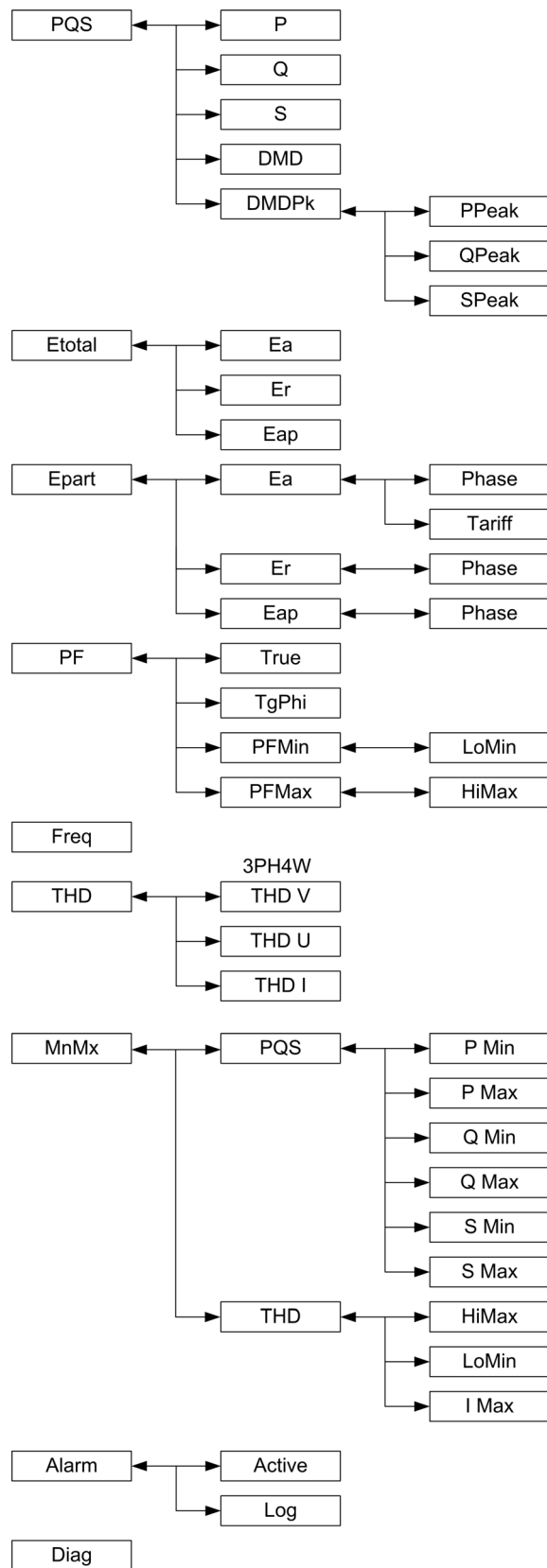



Display Mode Menu Tree for PM3255

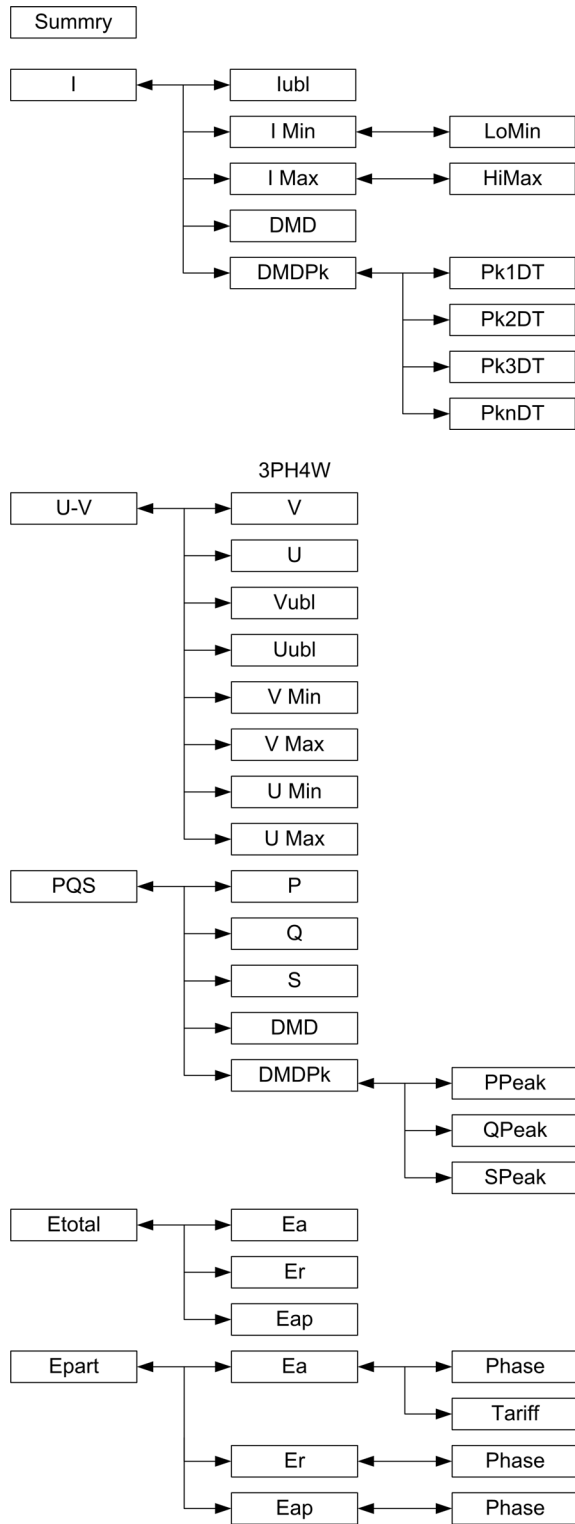

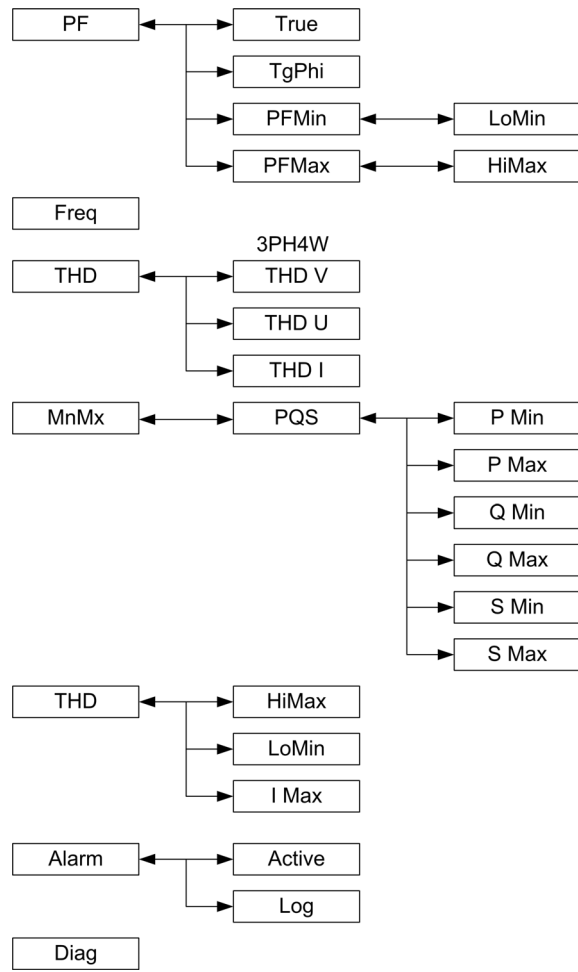

## Full Screen Mode

### Presentation

The main title and the sub menu in full screen mode are hidden and the values are expanded to full screen. The following screen illustrates an example of full screen page:

Vavg	221.0	V
Iavg	5.005	A
Ptot	3.321	kW
Ea	17.0	Wh

Full screen mode is enabled by default. You can modify full screen enable/disable information, auto scroll enable/disable, and auto scroll interval in HMI configuration.

Full Screen	Auto Scroll	Auto Scroll Interval	Description
Enable	Disable	Any value	Fixed summary page at full screen mode.
Enable	Enable	Any value	Auto scrolling pages at full screen mode. The interval between any two scrolling pages is the value specified.
Disable	—	—	Full screen mode disabled.

### Enter the Full Screen Mode

If Full Screen mode is enabled, press **ESC** to switch from Configuration mode (**Setup** page) to Full Screen mode.

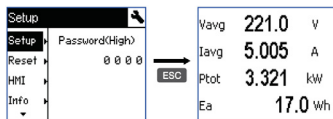

If Full Screen mode is enabled and without key pressing for 5 minutes, Display mode switches to Full Screen mode.



### Full Screen Mode Menu Tree for PM3200

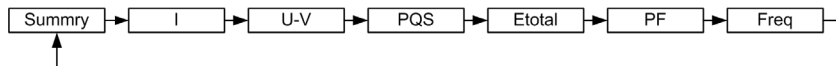

### Full Screen Mode Menu Tree for PM3210/ PM3250/ PM3255

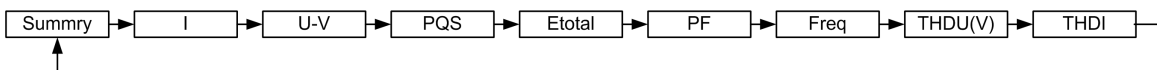



---

## What Is in This Chapter?

This chapter contains the following sections:

Section	Topic	Page
5.1	Modbus Configuration	62
5.2	Modbus Functions	63
5.3	Command Interface	66
5.4	Modbus Register Table	74
5.5	Read Device Identification	89

## 5.1 Modbus Configuration

### Configuration of RS-485 Communication Port

#### Communication Parameters

Before initiating any communication processes, configure the Modbus communication port via the human machine interface (**Setup** → **Comm** menu command):

Parameters	Authorized Values	Default Value
Baud rate	<ul style="list-style-type: none"> <li>● 9600 Baud</li> <li>● 19 200 Baud</li> <li>● 38 400 Baud</li> </ul>	19 200 Baud
Parity	<ul style="list-style-type: none"> <li>● Odd</li> <li>● Even</li> <li>● None</li> </ul> <p><b>NOTE:</b> number of stop bit = 1</p>	Even
Address	1–247	1

#### Signaling of Communication Activity

The yellow communication LED indicates the status of communication between the Power Meters (PMs) and the master as follows:

If...	Then...
The LED is flashing	Communication with the device has been correctly established
The LED is off	There is no active communication between the master and the slave

---

## 5.2 Modbus Functions

---

### What Is in This Section?

This section contains the following topics:

Topic	Page
Function List	64
Table Format	65

## Function List

### Introduction

There are 3 different ways of using the Modbus communication:

- by sending commands using the command interface (*see page 66*),
- by reading the Modbus registers (*see page 74*).
- by reading the Device Identification (*see page 89*).

### Description

Sending commands using the command interface is supported by Modbus function 16.

Reading Modbus registers is supported by Modbus function 3.

Read Device Identification is supported by Modbus function 43/14.

The table below describes the three Modbus functions:

Function Code		Function Name
Decimal	Hexadecimal	
3	0x03	Read Holding Registers
16	0x10	Write Multiple Registers
43/14	0x2B/0x0E	Read Device Identification

For example:

- To read different parameters from the power meter, use the function 3 (Read).
- To change the tariff, use the function 16 (Write) by sending a command to the power meter.



## Table Format

Register tables have the following columns:

Register Address	Action (R/W/WC)	Size	Type	Units	Range	Description
------------------	-----------------	------	------	-------	-------	-------------

- **Register Address:** Modbus address of register encoded in the Modbus frame, in decimal (dec)
- **Action:** The read/write/write by command property of the register
- **Size:** The data size in Int16
- **Type:** The encoding data type
- **Units:** The unit of the register value
- **Range:** The permitted values for this variable, usually a subset of what the format allows
- **Description:** Provides information about the register and the values that apply

## Unit Table

The following data types appear in the Modbus register list:

Type	Description	Range
UInt16	16 bit unsigned integer	0...65535
Int16	16 bit signed integer	-32768...+32767
UInt32	32 bit unsigned integer	0...4 294 967 295
UTF8	8 bit field	multibyte character encoding for Unicode
Float32	32 bit value	Standard representation IEEE for floating number (with single precision)
Bitmap	–	–
DATETIME	See below	–

DATETIME format:

Word	Bits															
	15	14	13	12	11	10	9	8	7	6	5	4	3	2	1	0
1	Reserved (0)								R4 (0)		Year (0...127)					
2	0				Month (1...12)				WD (0)				Day (1...31)			
3	SU (0)		0		Hour (0...23)				iV		0		Minute (0...59)			
4	Millisecond (0...59999)															
<b>R4 :</b>								Reserved Bit								
<b>Year :</b>								7 bits: (year from 2000)								
<b>Month :</b>								4 bits								
<b>Day :</b>								5 bits								
<b>Hour :</b>								5 bits								
<b>Minute :</b>								6 bits								
<b>Millisecond :</b>								2 octets								
<b>WD (day of the week) :</b>								1-7: Sunday to Saturday								
<b>SU (summer time) :</b>								Bit to 0 if this parameter is not used.								
<b>iV (validity of received data) :</b>								Bit to 0 if this parameter is not valid or not used.								

## 5.3 Command Interface

---

### What Is in This Section?

This section contains the following topics:

Topic	Page
Presentation	67
Command List	68

## Presentation

### Description

The command interface allows to configure the power meter by sending specific command requests using Modbus function 16.

### Command Request

The following table describes a Modbus command request:

Slave Number	Function Code	Command block		CRC
		Register Address	Command Description	
1–247	16 (W)	5250 (up to 5374)	The command is made of a command number and a set of parameters. See the detailed description of each command in the command list. <b>NOTE:</b> All the reserved parameters can be considered as any value, e.g. 0.	Checking

The following table describes a command block:

Register Address	Content	Size (Int16)	Data (example)
5250	Command Number	1	2008 (Set Tariff)
5251	(Reserved)	1	0
5252–5374	Parameter	n	4 (Tariff=4) <b>NOTE:</b> Command number 2008 supports only one parameter with the size of 1.

### Command Result

The command result can be obtained by reading registers 5375 and 5376.

The following table describes the command result:

Register Address	Content	Size (Int16)	Data (example)
5375	Requested Command Number	1	2008 (Set Tariff)
5376	Result <sup>(1)</sup>	1	0 (Valid Operation)

<sup>(1)</sup> List of Command Result codes:

- 0 = Valid Operation
- 3000 = Invalid Command
- 3001 = Invalid Parameter
- 3002 = Invalid Number of Parameters
- 3007 = Operation Not Performed

## Command List

The following commands are available:

<b>Command</b>	<b>Relevant Command Number</b>	<b>Page</b>
Set Date/Time	1003	<i>(see page 69)</i>
Set Wiring	2000	<i>(see page 69)</i>
Demand System Setup	2002	<i>(see page 70)</i>
Set Pulse Output (PM3255)	2003, 2038	<i>(see page 70)</i>
Set Tariff	2008, 2060	<i>(see page 70)</i>
Reset All Minimum/Maximum	2009	<i>(see page 71)</i>
Reset All Peak demands	2015	<i>(see page 71)</i>
Set Digital Input as Partial Energy Reset (PM3255)	6017	<i>(see page 71)</i>
Input Metering Setup (PM3255)	6014	<i>(see page 71)</i>
Alarm Setup	7000, 20000, 20001	<i>(see page 72)</i>
Communications Setup	5000	<i>(see page 73)</i>
Reset Partial Energy Counters	2020	<i>(see page 73)</i>
Reset Input Metering Counter (PM3255)	2023	<i>(see page 73)</i>

## Set Date/Time

Command Number	Action (R/W)	Size	Type	Unit	Range	Description
1003	W	1	UInt16	–	–	(Reserved)
	W	1	UInt16	–	2000–2099	Year
	W	1	UInt16	–	1–12	Month
	W	1	UInt16	–	1–31	Day
	W	1	UInt16	–	0–23	Hour
	W	1	UInt16	–	0–59	Minute
	W	1	UInt16	–	0–59	Second
	W	1	UInt16	–	–	(Reserved)

## Set Wiring

Command Number	Action (R/W)	Size	Type	Unit	Range	Description
2000	W	1	UInt16	–	–	(Reserved)
	W	1	UInt16	–	–	(Reserved)
	W	1	UInt16	–	–	(Reserved)
	W	1	UInt16	–	0, 1, 2, 3, 11, 13	Power System Configuration 0 = 1PH2W L-N 1 = 1PH2W L-L 2 = 1PH3W L-L-N 3 = 3PH3W 11 = 3PH4W 13 = 1PH4W L-N
	W	1	UInt16	Hz	50, 60	Nominal Frequency
	W	2	Float32	–	–	(Reserved)
	W	2	Float32	–	–	(Reserved)
	W	2	Float32	–	–	(Reserved)
	W	1	UInt16	–	–	(Reserved)
	W	1	UInt16	–	–	(Reserved)
	W	2	Float32	V	VT Secondary–1000000.0	VT Primary
	W	1	UInt16	V	100, 110, 115, 120	VT Secondary
	W	1	UInt16	–	1, 2, 3	Number of CTs
	W	1	UInt16	A	1–32767	CT Primary
	W	1	UInt16	A	1, 5	CT Secondary
	W	1	UInt16	–	–	(Reserved)
	W	1	UInt16	–	–	(Reserved)
	W	1	UInt16	–	–	(Reserved)
	W	1	UInt16	–	0, 1, 2	VT Connection type: 0 = Direct Connect 1 = Delta (2 VTs) 2 = Wye (3 VTs)

**Demand System Setup**

Command Number	Action (R/W)	Size	Type	Unit	Range	Description
2002	W	1	UInt16	–	–	(Reserved)
	W	1	UInt16	–	–	(Reserved)
	W	1	UInt16	–	1, 2	Demand method: 1 = Timed interval sliding block 2 = Timed interval fixed block
	W	1	UInt16	min	10, 15, 20, 30, 60	Demand interval duration
	W	1	UInt16	–	–	(Reserved)

**Set Pulse Output (PM3255)**

Command Number	Action (R/W)	Size	Type	Unit	Range	Description
2003	W	1	UInt16	–	–	(Reserved)
	W	1	UInt16	–	–	(Reserved)
	W	1	UInt16	–	0, 1	Pulse Output 0 = DO1 Disable 1 = DO1 Enable
	W	2	Float32	pulse/kWh	0.01, 0.1, 1, 10, 100, 500	Active Energy Pulse Frequency
	W	1	UInt16	–	–	(Reserved)
	W	1	UInt16	–	0, 2	0 = DO2 Disable 2 = DO2 Enable
	W	2	Float32	pulse/kVARh	0.01, 0.1, 1, 10, 100, 500	Reactive Energy Pulse Frequency
	W	1	UInt16	–	–	(Reserved)
	W	1	UInt16	–	–	(Reserved)
	W	2	Float32	–	–	(Reserved)
2038	W	1	UInt16	–	–	(Reserved)
	W	1	UInt16	–	–	(Reserved)
	W	1	UInt16	ms	50, 100, 200, 300	Energy Pulse Duration

**Set Tariff**

Command Number	Action (R/W)	Size	Type	Unit	Range	Description
2060	W	1	UInt16	–	–	(Reserved)
	W	1	UInt16	–	0–3	Multi-tariff mode: 0 = Disable Multi-tariff 1 = Use COM as Tariff Control (maximum 4 tariffs) 2 = Use DI1 as Tariff Control (2 tariffs) 3 = Use 2 Digital inputs as Tariff Control (4 tariffs) 4 = Use RTC as Tariff Control (maximum 4 tariffs)
2008	W	1	UInt16	–	–	(Reserved)
	W	1	UInt16	–	1–4	Tariff <sup>(1)</sup> 1 = T1 2 = T2 3 = T3 4 = T4

<sup>(1)</sup> Only if Multi-Tariff is controlled by COM.

**Reset All Minimum/Maximum**

Command Number	Action (R/W)	Size	Type	Unit	Range	Description
2009	W	1	UInt16	–	–	(Reserved)

**Reset All Peak Demands**

Command Number	Action (R/W)	Size	Type	Unit	Range	Description
2015	W	1	UInt16	–	–	(Reserved)

**Set Digital Input as Partial Energy Reset (PM3255)**

Command Number	Action (R/W)	Size	Type	Unit	Range	Description
6017	W	1	UInt16	–	–	(Reserved)
	W	1	UInt16	–	0, 1, 2, 3	Digital Input to Associate: 0 = None 1 = DI1 2 = DI2 3 = DI1 and DI2

**Input Metering Setup (PM3255)**

Command Number	Action (R/W)	Size	Type	Unit	Range	Description
6014	W	1	UInt16	–	–	(Reserved)
	W	1	UInt16	–	1, 2	Input Metering Channel
	W	20	UTF8	–	string size ≤40	Label
	W	2	Float32	–	1–10000	Pulse Weight
	W	1	UInt16	–	–	(Reserved)
	W	1	UInt16	–	Input Metering Channel 1: 0, 1 Input Metering Channel 2: 0, 2	Digital Input Association: 0 = None 1 = DI1 2 = DI2

**Alarm Setup**

Command Number	Action (R/W)	Size	Type	Unit	Range	Description
7000	W	1	UInt16	–	–	(Reserved)
	W	1	UInt16	–	(1) (2)	Alarm ID
	W	1	UInt16	–	–	(Reserved)
	W	1	UInt16	–	–	(Reserved)
	W	1	UInt16	–	–	(Reserved)
	W	1	UInt16	–	0, 1	0 = Disable 1 = Enable
	W	2	Float32	–	(3) (4) (5) (6) (7)	Pickup Setpoint
	W	2	UInt32	–	–	(Reserved)
	W	2	Float32	–	–	(Reserved)
	W	2	UInt32	–	–	(Reserved)
	W	1	UInt16	–	–	(Reserved)
	W	4	UInt16	–	–	(Reserved)
	W	1	UInt16	–	–	(Reserved)
	W	1	UInt16	–	–	(Reserved)
	20000	W	1	UInt16	–	–
W		2	Float32	–	0.0–99.0	Dropout Setpoint
W		2	UInt32	–	0–999999	Trip Time Delay
W		1	Bitmap	–	0, 1, 2, 3	PM 3250: Reserved PM 3255: Digital Output to Associate: 0 = None 1 = DO1 2 = DO2 3 = DO1 and DO2
20001	W	1	UInt16	–	–	(Reserved)
<p><b>NOTE:</b> <sup>(1)</sup> PM3250: 1, 6, 8, 9, 11, 30  <sup>(2)</sup> PM3255: 1, 2, 5, 6, 7, 8, 9, 10, 11, 12, 13, 16, 19, 28, 30, 31, 32, 41  <sup>(3)</sup> Alarm ID 1, 2, 5, 6, 7, 8, 11, 19: 0.0–9999999.0  <sup>(4)</sup> Alarm ID 9, 10, 16, 30: –9999999.0–9999999.0  <sup>(5)</sup> Alarm ID 12, 13: –2.0–2.0  <sup>(6)</sup> Alarm ID 28, 31, 32: 0.0–1000.0  <sup>(7)</sup> Alarm ID 41: 0–999999999</p>						



**Communications Setup**

Command Number	Action (R/W)	Size	Type	Unit	Range	Description
5000	W	1	UInt16	–	–	(Reserved)
	W	1	UInt16	–	–	(Reserved)
	W	1	UInt16	–	–	(Reserved)
	W	1	UInt16	–	1–247	Address
	W	1	UInt16	–	0, 1, 2	Baud Rate 0 = 9600 1 = 19 200 2 = 38 400
	W	1	UInt16	–	0, 1, 2	Parity 0 = Even 1 = Odd 2 = None
	W	1	UInt16	–	–	(Reserved)

**Reset Partial Energy Counters**

Command Number	Action (R/W)	Size	Type	Unit	Range	Description
2020	W	1	UInt16	–	–	(Reserved)

**Reset Input Metering Counter (PM3255)**

Command Number	Action (R/W)	Size	Type	Unit	Range	Description
2023	W	1	UInt16	–	–	(Reserved)

## 5.4 Modbus Register Table

### Register List

The following table lists the accessible registers:

<b>Register</b>	<b>Page</b>
System	<i>(see page 75)</i>
Meter Setup and Status	<i>(see page 75)</i>
Energy Pulse Output Setup	<i>(see page 75)</i>
Command Interface	<i>(see page 76)</i>
Communication	<i>(see page 76)</i>
Input Metering Setup	<i>(see page 76)</i>
Digital Inputs	<i>(see page 77)</i>
Digital Outputs	<i>(see page 77)</i>
Basic Meter Data	<i>(see page 77)</i>
Demand	<i>(see page 79)</i>
MinMax Reset	<i>(see page 80)</i>
Minimum Values	<i>(see page 80)</i>
Maximum Values	<i>(see page 81)</i>
MinMax with Time Stamp	<i>(see page 82)</i>
Power Quality	<i>(see page 82)</i>
Alarms	<i>(see page 83)</i>
Energy Log	<i>(see page 87)</i>

## System

Register Address	Action (R/W/WC)		Size	Type	Units	Description
	PM3250	PM3255				
30	R	R	20	UTF8	–	Meter Name
50	R	R	20	UTF8	–	Meter Model
70	R	R	20	UTF8	–	Manufacturer
130	R	R	2	UInt32	–	Serial Number
132	R	R	4	Date/Time	–	Date of Manufacture
136	R	R	5	UTF8	–	Hardware Revision
1637	R	R	1	UInt16	–	Present Firmware Version (DLF format): X.Y.ZTT
1701	R	R	1	UInt16	–	Present Language Version (DLF format): X.Y.ZTT
1845–1848	R/WC	R/WC	1 X 4	UInt16	–	Date/Time Reg. 1845: Year 0-99 (year from 2000 to 2099) Reg. 1846: Month (b11:b8), Weekday (b7:b5), Day (b4:b0) Reg. 1847: Hour (b12:b8) and Minute (b5:b0) Reg. 1848: Millisecond

## Meter Setup and Status

Register Address	Action (R/W/WC)		Size	Type	Units	Description
	PM3250	PM3255				
2004	R	R	2	UInt32	Second	Meter Operation Timer Status
2014	R	R	1	UInt16	–	Number of Phases
2015	R	R	1	UInt16	–	Number of Wires
2016	R/WC	R/WC	1	UInt16	–	Power System Configuration: 0 = 1PH2W L–N 1 = 1PH2W L–L 2 = 1PH3W L–L with N 3 = 3PH3W 11 = 3PH4W 13 = 1PH4W multi L with N
2017	R/WC	R/WC	1	UInt16	Hz	Nominal Frequency
2024	R/WC	R/WC	1	UInt16	–	Nominal Phase Order: 0 = A-B-C 1 = C-B-A
2025	R	R	1	UInt16	–	Number VTs
2026	R/WC	R/WC	2	Float32	V	VT Primary
2028	R/WC	R/WC	1	UInt16	V	VT Secondary
2029	R/WC	R/WC	1	UInt16	–	Number CTs
2030	R/WC	R/WC	1	UInt16	A	CT Primary
2031	R/WC	R/WC	1	UInt16	A	CT Secondary
2036	R/WC	R/WC	1	UInt16	–	VT Connection Type: 0 = Direct Connect 1 = 3PH3W (2 VTs) 2 = 3PH4W (3 VTs)

## Energy Pulse Output Setup

Register Address	Action (R/W/WC)		Size	Type	Units	Description
	PM3250	PM3255				
Energy Output Pulses (Global Settings)						
2129	–	R/WC	1	UInt16	Millisecond	Energy Pulse Duration
Active Energy Pulse Output Channel						

Register Address	Action (R/W/WC)		Size	Type	Units	Description
	PM3250	PM3255				
2131	–	R/WC	1	UInt16	–	Digital Output Association: 0 = Disable 1 = DO1 enable for active energy pulse output
2132	–	R/WC	2	Float32	pulse/kWh	Active Energy Pulse Frequency
Reactive Energy Pulse Output Channel						
2135	–	R/WC	1	UInt16	–	Digital Output Association: 0 = Disable 1 = DO2 enable for reactive energy pulse output
2136	–	R/WC	2	Float32	pulse/kVARh	Reactive Energy Pulse Frequency

### Command Interface

Register Address	Action (R/W/WC)		Size	Type	Units	Description
	PM3250	PM3255				
5250	R/W	R/W	1	UInt16	–	Requested Command
5252	R/W	R/W	1	UInt16	–	Command Parameter 001
5374	R/W	R/W	1	UInt16	–	Command Parameter 123
5375	R	R	1	UInt16	–	Command Status
5376	R	R	1	UInt16	–	Command Result codes: <ul style="list-style-type: none"> <li>● 0 = Valid Operation</li> <li>● 3000 = Invalid Command</li> <li>● 3001 = Invalid Parameter</li> <li>● 3002 = Invalid Number of Parameters</li> <li>● 3007 = Operation Not Performed</li> </ul>
5377	R	R	1	UInt16	–	Command Data 001
5499	R	R	1	UInt16	–	Command Data 123

### Communications

Register Address	Action (R/W/WC)		Size	Type	Units	Description
	PM3250	PM3255				
6500	R	R	1	UInt16	–	Protocol 0 = Modbus
6501	R/WC	R/WC	1	UInt16	–	Address
6502	R/WC	R/WC	1	UInt16	–	Baud Rate: 0 = 9600 1 = 19 200 2 = 38 400
6503	R/WC	R/WC	1	UInt16	–	Parity: 0 = Even 1 = Odd 2 = None

### Input Metering Setup

Register Address	Action R/W/WC)		Size	Type	Units	Description
	PM3250	PM3255				
Input Metering Channel 01						
7032	–	R/WC	20	UTF8	–	Label
7052	–	R/WC	2	Float32	pulse/unit	Pulse Frequency
7055	–	R/WC	1	UInt16	–	Digital Input Association: 0 = DI1 disable for input metering 1 = DI1 enable for input metering
Input Metering Channel 02						
7056	–	R/WC	20	UTF8	–	Label

Register Address	Action R/W/WC		Size	Type	Units	Description
	PM3250	PM3255				
7076	–	R/WC	2	Float32	pulse/unit	Pulse Frequency
7079	–	R/WC	1	UInt16	–	Digital Input Association: 0 = DI2 disable for input metering 2 = DI2 enable for input metering

### Digital Inputs

Register Address	Action (R/W/WC)		Size	Type	Units	Description
	PM3250	PM3255				
7274	–	R	1	UInt16	–	Digital Input 1 Control Mode: 0 = Normal (Input Status) 2 = Multi-tariff Control 3 = Input Metering 5 = Energy Reset (Partial Energy, Energy by Tariff, Phase Energy)
7298	–	R	1	UInt16	–	Digital Input 2 Control Mode
8905	–	R	2	Bitmap	–	Digital Input Status: 0 = Relay-Open 1 = Relay-Closed Bit 1 = DI1 status Bit 2 = DI2 status

### Digital Outputs

Register Address	Action (R/W/WC)		Size	Type	Units	Description
	PM3250	PM3255				
9673	–	R	1	UInt16	–	Digital Output 1 Control Mode Status: 2 = Alarm 3 = Energy 0xFFFF = Disable
9681	–	R	1	UInt16	–	Digital Output 2 Control Mode Status

### Basic Meter Data

Register Address	Action (R/W/WC)		Size	Type	Units	Description
	PM3250	PM3255				
Current						
3000	R	R	2	Float32	A	I1: phase 1 current
3002	R	R	2	Float32	A	I2: phase 2 current
3004	R	R	2	Float32	A	I3: phase 3 current
3006	R	R	2	Float32	A	In: Neutral current
3010	R	R	2	Float32	A	Current Avg
Voltage						
3020	R	R	2	Float32	V	Voltage L1-L2
3022	R	R	2	Float32	V	Voltage L2-L3
3024	R	R	2	Float32	V	Voltage L3-L1
3026	R	R	2	Float32	V	Voltage L-L Avg
3028	R	R	2	Float32	V	Voltage L1-N
3030	R	R	2	Float32	V	Voltage L2-N
3032	R	R	2	Float32	V	Voltage L3-N
3036	R	R	2	Float32	V	Voltage L-N Avg
Power						
3054	R	R	2	Float32	kW	Active Power Phase 1
3056	R	R	2	Float32	kW	Active Power Phase 2
3058	R	R	2	Float32	kW	Active Power Phase 3

Register Address	Action (R/W/WC)		Size	Type	Units	Description
	PM3250	PM3255				
3060	R	R	2	Float32	kW	Total Active Power
3062	R	R	2	Float32	kVAR	Reactive Power Phase 1
3064	R	R	2	Float32	kVAR	Reactive Power Phase 2
3066	R	R	2	Float32	kVAR	Reactive Power Phase 3
3068	R	R	2	Float32	kVAR	Total Reactive Power
3070	R	R	2	Float32	kVA	Apparent Power Phase 1
3072	R	R	2	Float32	kVA	Apparent Power Phase 2
3074	R	R	2	Float32	kVA	Apparent Power Phase 3
3076	R	R	2	Float32	kVA	Total Apparent Power
Power Factor						
3078	R	R	2	Float32	–	Power Factor Phase 1 (Complex format)
3080	R	R	2	Float32	–	Power Factor Phase 2 (Complex format)
3082	R	R	2	Float32	–	Power Factor Phase 3 (Complex format)
3084	R	R	2	Float32	–	Power Factor Total: -2<PF<-1: Quad 2, active power negative, capacitive -1<PF<0: Quad 3, active power negative, inductive 0<PF<1: Quad 1, active power positive, inductive 1<PF<2: Quad 4, active power positive, capacitive
Current Unbalance						
3012	R	R	2	Float32	%	Current Unbalance I1
3014	R	R	2	Float32	%	Current Unbalance I2
3016	R	R	2	Float32	%	Current Unbalance I3
3018	R	R	2	Float32	%	Current Unbalance Worst
Voltage Unbalance						
3038	R	R	2	Float32	%	Voltage Unbalance L1-L2
3040	R	R	2	Float32	%	Voltage Unbalance L2-L3
3042	R	R	2	Float32	%	Voltage Unbalance L3-L1
3044	R	R	2	Float32	%	Voltage Unbalance L-L Worst
3046	R	R	2	Float32	%	Voltage Unbalance L1-N
3048	R	R	2	Float32	%	Voltage Unbalance L2-N
3050	R	R	2	Float32	%	Voltage Unbalance L3-N
3052	R	R	2	Float32	%	Voltage Unbalance L-N Worst
Tangent Phi (Reactive Factor)						
3108	R	R	2	Float32	–	Tangent Phi, Total
Frequency						
3110	R	R	2	Float32	Hz	Frequency
Temperature						
3132	R	R	2	Float32	°C	Temperature
Total Energy						
3204	R	R	4	Int64	Wh	Total Active Energy Import
3208	R	R	4	Int64	Wh	Total Active Energy Export
3220	R	R	4	Int64	VARh	Total Reactive Energy Import
3224	R	R	4	Int64	VARh	Total Reactive Energy Export
3236	R	R	4	Int64	VAh	Total Apparent Energy Import
3240	R	R	4	Int64	VAh	Total Apparent Energy Export
Energy Reset (Partial Energy, Energy by Tariff, Phase Energy)						
3252	R	R	4	Date/Time	–	Energy Reset Date/Time
Partial Energy Import						

Register Address	Action (R/W/WC)		Size	Type	Units	Description
	PM3250	PM3255				
3256	R	R	4	Int64	Wh	Partial Active Energy Import
3272	R	R	4	Int64	VARh	Partial Reactive Energy Import
3288	R	R	4	Int64	VAh	Partial Apparent Energy Import
Phase Energy Import						
3518	R	R	4	Int64	Wh	Active Energy Import Phase 1
3522	R	R	4	Int64	Wh	Active Energy Import Phase 2
3526	R	R	4	Int64	Wh	Active Energy Import Phase 3
3530	R	R	4	Int64	VARh	Reactive Energy Import Phase 1
3534	R	R	4	Int64	VARh	Reactive Energy Import Phase 2
3538	R	R	4	Int64	VARh	Reactive Energy Import Phase 3
3542	R	R	4	Int64	VAh	Apparent Energy Import Phase 1
3546	R	R	4	Int64	VAh	Apparent Energy Import Phase 2
3550	R	R	4	Int64	VAh	Apparent Energy Import Phase 3
Energy by Tariff Import						
4191	R/WC	R/WC	1	UInt16	–	Active Tariff (Only modifiable in case of COM Control Mode Enabled): 0 = multi-tariff disabled 1-4 = rate 1 to rate 4
4196	R	R	4	Int64	Wh	Rate 1 Active Energy Import
4200	R	R	4	Int64	Wh	Rate 2 Active Energy Import
4204	R	R	4	Int64	Wh	Rate 3 Active Energy Import
4208	R	R	4	Int64	Wh	Rate 4 Active Energy Import
Input Metering						
3554	–	R	4	Date/Time	–	Input Metering Accumulation Reset Date/Time
3558	–	R	4	Int64	Unit	Input Metering Accumulation Channel 01
3562	–	R	4	Int64	Unit	Input Metering Accumulation Channel 02

## Demand

Register Address	Action (R/W/WC)		Size	Type	Units	Description
	PM3250	PM3255				
Demand System (Global)						
3701	R/WC	R/WC	1	UInt16	–	Demand Method: 1 = Timed Interval Sliding Block 2 = Timed Interval Fixed Block
3702	R/WC	R/WC	1	UInt16	Minute	Demand Interval Duration
3706	R	R	4	Date/Time	–	Demand Peak Reset Date/Time
Power/Current Demand						
3766	R	R	2	Float32	kW	Active Power Present Demand
3770	R	R	2	Float32	kW	Active Power Peak Demand
3772	R	R	4	Date/Time	–	Active Power Peak Demand Date/Time
3782	R	R	2	Float32	kVAR	Reactive Power Present Demand
3786	R	R	2	Float32	kVAR	Reactive Power Peak Demand
3788	R	R	4	Date/Time	–	Reactive Power Peak Demand Date/Time
3798	R	R	2	Float32	kVA	Apparent Power Present Demand
3802	R	R	2	Float32	kVA	Apparent Power Peak Demand
3804	R	R	4	Date/Time	–	Apparent Power Peak Demand Date/Time
3814	R	R	2	Float32	A	Current I1 Present Demand
3818	R	R	2	Float32	A	Current I1 Peak Demand
3820	R	R	4	Date/Time	–	Current I1 Peak Demand Date/Time
3830	R	R	2	Float32	A	Current I2 Present Demand
3834	R	R	2	Float32	A	Current I2 Peak Demand

Register Address	Action (R/W/WC)		Size	Type	Units	Description
	PM3250	PM3255				
3836	R	R	4	Date/Time	–	Current I2 Peak Demand Date/Time
3846	R	R	2	Float32	A	Current I3 Present Demand
3850	R	R	2	Float32	A	Current I3 Peak Demand
3852	R	R	4	Date/Time	–	Current I3 Peak Demand Date/Time
3862	R	R	2	Float32	A	Current In Present Demand
3866	R	R	2	Float32	A	Current In Peak Demand
3868	R	R	4	Date/Time	–	Current In Peak Demand Date/Time
3878	R	R	2	Float32	A	Current Avg Present Demand
3882	R	R	2	Float32	A	Current Avg Peak Demand
3884	R	R	4	Date/Time	–	Current Avg Peak Demand Date/Time

**MinMax Reset**

Register Address	Action (R/W/WC)		Size	Type	Units	Description
	PM3250	PM3255				
27214	R	R	4	Date/Time	–	Minimum/Maximum Reset Date/Time

**Minimum Values**

Register Address	Action (R/W/WC)		Size	Type	Units	Description
	PM3250	PM3255				
Current						
27218	R	R	2	Float32	A	Minimum Current I1
27220	R	R	2	Float32	A	Minimum Current I2
27222	R	R	2	Float32	A	Minimum Current I3
27224	R	R	2	Float32	A	Minimum Current N
27228	R	R	2	Float32	A	Minimum Current Avg
Voltage						
27238	R	R	2	Float32	V	Minimum Voltage L1-L2
27240	R	R	2	Float32	V	Minimum Voltage L2-L3
27242	R	R	2	Float32	V	Minimum Voltage L3-L1
27244	R	R	2	Float32	V	Minimum Voltage L-L Avg
27246	R	R	2	Float32	V	Minimum Voltage L1-N
27248	R	R	2	Float32	V	Minimum Voltage L2-N
27250	R	R	2	Float32	V	Minimum Voltage L3-N
27254	R	R	2	Float32	V	Minimum Voltage L-N Avg
Power						
27272	R	R	2	Float32	kW	Minimum Active Power Phase 1
27274	R	R	2	Float32	kW	Minimum Active Power Phase 2
27276	R	R	2	Float32	kW	Minimum Active Power Phase 3
27278	R	R	2	Float32	kW	Minimum Active Power Total
27280	R	R	2	Float32	kVAR	Minimum Reactive Power Phase 1
27282	R	R	2	Float32	kVAR	Minimum Reactive Power Phase 2
27284	R	R	2	Float32	kVAR	Minimum Reactive Power Phase 3
27286	R	R	2	Float32	kVAR	Minimum Reactive Power Total
27288	R	R	2	Float32	kVA	Minimum Apparent Power Phase 1
27290	R	R	2	Float32	kVA	Minimum Apparent Power Phase 2
27292	R	R	2	Float32	kVA	Minimum Apparent Power Phase 3
27294	R	R	2	Float32	kVA	Minimum Apparent Power Total
Power Factor						
27306	R	R	2	4Q FP PF	–	Minimum Power Factor Phase 1



Register Address	Action (R/W/WC)		Size	Type	Units	Description
	PM3250	PM3255				
27308	R	R	2	4Q FP PF	–	Minimum Power Factor Phase 2
27310	R	R	2	4Q FP PF	–	Minimum Power Factor Phase 3
27312	R	R	2	4Q FP PF	–	Minimum Power Factor Total
Tangent Phi (Reactive Factor)						
27336	R	R	2	Float32	–	Minimum Tangent Phi, Total
Total Harmonic Distortion, Current						
27338	R	R	2	Float32	%	Minimum THD Current I1
27340	R	R	2	Float32	%	Minimum THD Current I2
27342	R	R	2	Float32	%	Minimum THD Current I3
27344	R	R	2	Float32	%	Minimum THD Current N
Total Harmonic Distortion, Voltage						
27360	R	R	2	Float32	%	Minimum THD Voltage L1-L2
27362	R	R	2	Float32	%	Minimum THD Voltage L2-L3
27364	R	R	2	Float32	%	Minimum THD Voltage L3-L1
27366	R	R	2	Float32	%	Minimum THD Voltage L-L Avg
27368	R	R	2	Float32	%	Minimum THD Voltage L1-N
27370	R	R	2	Float32	%	Minimum THD Voltage L2-N
27372	R	R	2	Float32	%	Minimum THD Voltage L3-N
27376	R	R	2	Float32	%	Minimum THD Voltage L-N Avg
Frequency						
27616	R	R	2	Float32	Hz	Minimum Frequency

### Maximum Values

Register Address	Action (R/W/WC)		Size	Type	Units	Description
	PM3250	PM3255				
Current						
27694	R	R	2	Float32	A	Maximum Current I1
27696	R	R	2	Float32	A	Maximum Current I2
27698	R	R	2	Float32	A	Maximum Current I3
27700	R	R	2	Float32	A	Maximum Current N
27704	R	R	2	Float32	A	Maximum Current Avg
Voltage						
27714	R	R	2	Float32	V	Maximum Voltage L1-L2
27716	R	R	2	Float32	V	Maximum Voltage L2-L3
27718	R	R	2	Float32	V	Maximum Voltage L3-L1
27720	R	R	2	Float32	V	Maximum Voltage L-L Avg
27722	R	R	2	Float32	V	Maximum Voltage L1-N
27724	R	R	2	Float32	V	Maximum Voltage L2-N
27726	R	R	2	Float32	V	Maximum Voltage L3-N
27730	R	R	2	Float32	V	Maximum Voltage L-N Avg
Power						
27748	R	R	2	Float32	kW	Maximum Active Power Phase 1
27750	R	R	2	Float32	kW	Maximum Active Power Phase 2
27752	R	R	2	Float32	kW	Maximum Active Power Phase 3
27754	R	R	2	Float32	kW	Maximum Active Power Total
27756	R	R	2	Float32	kVAR	Maximum Reactive Power Phase 1
27758	R	R	2	Float32	kVAR	Maximum Reactive Power Phase 2
27760	R	R	2	Float32	kVAR	Maximum Reactive Power Phase 3
27762	R	R	2	Float32	kVAR	Maximum Reactive Power Total

Register Address	Action (R/W/WC)		Size	Type	Units	Description
	PM3250	PM3255				
27764	R	R	2	Float32	kVA	Maximum Apparent Power Phase 1
27766	R	R	2	Float32	kVA	Maximum Apparent Power Phase 2
27768	R	R	2	Float32	kVA	Maximum Apparent Power Phase 3
27770	R	R	2	Float32	kVA	Maximum Apparent Power Total
Power Factor						
27782	R	R	2	4Q FP PF	–	Maximum Power Factor Phase 1
27784	R	R	2	4Q FP PF	–	Maximum Power Factor Phase 2
27786	R	R	2	4Q FP PF	–	Maximum Power Factor Phase 3
27788	R	R	2	4Q FP PF	–	Maximum Power Factor Total
Tangent Phi (Reactive Factor)						
27812	R	R	2	Float32	–	Maximum Tangent Phi, Total
Total Harmonic Distortion, Current						
27814	R	R	2	Float32	%	Maximum THD Current I1
27816	R	R	2	Float32	%	Maximum THD Current I2
27818	R	R	2	Float32	%	Maximum THD Current I3
27820	R	R	2	Float32	%	Maximum THD Current N
Total Harmonic Distortion, Voltage						
27836	R	R	2	Float32	%	Maximum THD Voltage L1-L2
27838	R	R	2	Float32	%	Maximum THD Voltage L2-L3
27840	R	R	2	Float32	%	Maximum THD Voltage L3-L1
27842	R	R	2	Float32	%	Maximum THD Voltage L-L
27844	R	R	2	Float32	%	Maximum THD Voltage L1-N
27846	R	R	2	Float32	%	Maximum THD Voltage L2-N
27848	R	R	2	Float32	%	Maximum THD Voltage L3-N
27852	R	R	2	Float32	%	Maximum THD Voltage L-N
Frequency						
28092	R	R	2	Float32	Hz	Maximum Frequency

**MinMax with Time Stamp**

Register Address	Action (R/W/WC)		Size	Type	Units	Description
	PM3250	PM3255				
45130	R	R	4	Date/Time	–	Minimum Current of I1,I2,I3 - Date/Time
45134	R	R	2	Float32	A	Minimum Current of I1,I2,I3 - Value
45136	R	R	4	Date/Time	–	Minimum Power Factor Total - Date/Time
45140	R	R	2	Float32	–	Minimum Power Factor Total - Value
45142	R	R	4	Date/Time	–	Maximum Current of I1,I2,I3 - Date/Time
45146	R	R	2	Float32	A	Maximum Current of I1,I2,I3 - Value
45148	R	R	4	Date/Time	–	Maximum Active Power Total - Date/Time
45152	R	R	2	Float32	kW	Maximum Active Power Total - Value
45154	R	R	4	Date/Time	–	Maximum Apparent Power Total - Date/Time
45158	R	R	2	Float32	kVA	Maximum Apparent Power Total - Value
45160	R	R	4	Date/Time	–	Maximum Power Factor Total - Date/Time
45164	R	R	2	Float32	–	Maximum Power Factor Total - Value

**Power Quality**

Register Address	Action (R/W/WC)		Size	Type	Units	Description
	PM3250	PM3255				
45100	R	R	2	Float32	%	THD Current I1
45102	R	R	2	Float32	%	THD Current I2

Register Address	Action (R/W/WC)		Size	Type	Units	Description
	PM3250	PM3255				
45104	R	R	2	Float32	%	THD Current I3
45106	R	R	2	Float32	%	THD Current Neutral
45108	R	R	2	Float32	%	THD Phase Current Worst
45110	R	R	2	Float32	%	THD Voltage L1-L2
45112	R	R	2	Float32	%	THD Voltage L2-L3
45114	R	R	2	Float32	%	THD Voltage L3-L1
45116	R	R	2	Float32	%	THD Voltage L-L Avg
45118	R	R	2	Float32	%	THD Voltage L-L Worst
45120	R	R	2	Float32	%	THD Voltage L1-N
45122	R	R	2	Float32	%	THD Voltage L2-N
45124	R	R	2	Float32	%	THD Voltage L3-N
45126	R	R	2	Float32	%	THD Voltage L-N Avg
45128	R	R	2	Float32	%	THD Voltage L-N Worst

## Alarms

Register Address	Action (R/W/WC)		Size	Type	Units	Description
	PM3250	PM3255				
<b>Alarm Status</b>						
Activated Alarm Bitmaps						
11021	R	R	1	Bitmap	–	0 = Alarm is inactive 1 = Alarm is active BitN = Alarm ID N (1-16)
11022	R	R	1	Bitmap	–	BitN = Alarm ID N (17-32)
11023	R	R	1	Bitmap	–	BitN = Alarm ID N (33-40) BitN fixed to 0
11024	R	R	1	Bitmap	–	BitN = Alarm ID N (41-56) BitN fixed to 0 for PM3250
Enabled Alarm Bitmaps						
11040	R	R	1	Bitmap	–	0 = Alarm is disabled 1 = Alarm is enabled BitN = Alarm ID N (1-16)
11041	R	R	1	Bitmap	–	BitN = Alarm ID N (17-32)
11042	R	R	1	Bitmap	–	BitN = Alarm ID N (33-40) BitN fixed to 0
11043	R	R	1	Bitmap	–	BitN = Alarm ID N (41-56) BitN fixed to 0 for PM3250
Unacknowledged Alarm Bitmaps						
11078	R	R	1	Bitmap	–	0 = Historic alarms are acknowledged by the user 1 = Historic alarms are unacknowledged by the user BitN = Alarm ID N (1-16)
11079	R	R	1	Bitmap	–	BitN = Alarm ID N (17-32)
11080	R	R	1	Bitmap	–	BitN = Alarm ID N (33-40) BitN fixed to 0
11081	R	R	1	Bitmap	–	BitN = Alarm ID N (41-56) BitN fixed to 0 for PM3250
<b>Alarm Event Queue</b>						
11113	R	R	1	UInt16	–	Size of Event Queue: fixed as 20
11114	R	R	1	UInt16	–	Number of entries in Event Queue
11115	R	R	1	UInt16	–	Entry number of Most Recent Event
Entry 001						
11116	R	R	1	UInt16	–	Entry Number

Register Address	Action (R/W/WC)		Size	Type	Units	Description
	PM3250	PM3255				
11117	R	R	4	Date/Time	–	Date/Time
11121	R	R	1	UInt16	–	Record Type: 0xFF10 = UInt16 0xFF40 = Float32
11122	R	R	1	UInt16	–	Register Number or Event Code: Primary Event: Modbus Address of the Unit Secondary Event: Event Code
11123	R	R	4	UInt16	–	Value: Primary Event: Alarm Attributes Register Address. Secondary Event: Worst value of source registers.
11127	R	R	1	UInt16	–	Sequence Number
<b>Entry 020</b>						
11344	R	R	1	UInt16	–	Entry Number
11345	R	R	4	Date/Time	–	Date/Time
11349	R	R	1	UInt16	–	Record Type
11350	R	R	1	UInt16	–	Register Number or Event Code
11351	R	R	4	UInt16	–	Value
11355	R	R	1	UInt16	–	Sequence Number
<b>Alarm History Log</b>						
12316	R	R	1	UInt16	–	Size of History Log
12317	R	R	1	UInt16	–	Number of entries in History Log
12318	R	R	1	UInt16	–	Entry number of most Recent Event
<b>Entry 001</b>						
12319	R	R	1	UInt16	–	Entry Number
12320	R	R	4	Date/Time	–	Date/Time
12324	R	R	1	UInt16	–	Record Type: 0xFF10 = UInt16 0xFF40 = Float32
12325	R	R	1	UInt16	–	Register Number or Event Code: Primary Event: Modbus Address of the Unit Secondary Event: Event Code
12326	R	R	4	UInt16	–	Value: Primary Event: Alarm Attributes Register Address Secondary Event: Worst value of source registers
12330	R	R	1	UInt16	–	Sequence Number
<b>Entry 020</b>						
12547	R	R	1	UInt16	–	Entry Number
12548	R	R	4	Date/Time	–	Date/Time
12552	R	R	1	UInt16	–	Record Type
12553	R	R	1	UInt16	–	Register Number or Event Code
12554	R	R	4	UInt16	–	Value
12558	R	R	1	UInt16	–	Sequence Number
<b>1- Second Alarms - Standard</b>						
Over Current, Phase					Alarm ID = 1	
14005	R/WC	R/WC	2	Float32	A	Pickup Setpoint
14007	R/WC	R/WC	2	UInt32	Second	Pickup Time Delay
14009	R/WC	R/WC	2	Float32	%	Dropout Setpoint Deviation percentage from pickup setpoint
14011	R/WC	R/WC	2	UInt32	Second	Dropout Time Delay Same as pickup time delay

Register Address	Action (R/W/WC)		Size	Type	Units	Description
	PM3250	PM3255				
14013	R/WC	R/WC	1	Bitmap	–	Digital Outputs to Associate: 0 = Unassociated 1 = Associated Bit0 = DO1 association Bit1 = DO2 association
Under Current, Phase						Alarm ID = 2
14025	–	R/WC	2	Float32	A	Pickup Setpoint
14027	–	R/WC	2	UInt32	Second	Pickup Time Delay
14029	–	R/WC	2	Float32	%	Dropout Setpoint
14031	–	R/WC	2	UInt32	Second	Dropout Time Delay
14033	–	R/WC	1	Bitmap	–	Digital Outputs to Associate
Over Voltage, L-L						Alarm ID = 5
14085	–	R/WC	2	Float32	V	Pickup Setpoint
14087	–	R/WC	2	UInt32	Second	Pickup Time Delay
14089	–	R/WC	2	Float32	%	Dropout Setpoint
14091	–	R/WC	2	UInt32	Second	Dropout Time Delay
14093	–	R/WC	1	Bitmap	–	Digital Outputs to Associate
Under Voltage, L-L						Alarm ID = 6
14105	R/WC	R/WC	2	Float32	V	Pickup Setpoint
14107	R/WC	R/WC	2	UInt32	Second	Pickup Time Delay
14109	R/WC	R/WC	2	Float32	%	Dropout Setpoint
14111	R/WC	R/WC	2	UInt32	Second	Dropout Time Delay
14113	R/WC	R/WC	1	Bitmap	–	Digital Outputs to Associate
Over Voltage, L-N						Alarm ID = 7
14125	–	R/WC	2	Float32	V	Pickup Setpoint
14127	–	R/WC	2	UInt32	Second	Pickup Time Delay
14129	–	R/WC	2	Float32	%	Dropout Setpoint
14131	–	R/WC	2	UInt32	Second	Dropout Time Delay
14133	–	R/WC	1	Bitmap	–	Digital Outputs to Associate
Under Voltage, L-N						Alarm ID = 8
14145	R/WC	R/WC	2	Float32	V	Pickup Setpoint
14147	R/WC	R/WC	2	UInt32	Second	Pickup Time Delay
14149	R/WC	R/WC	2	Float32	%	Dropout Setpoint
14151	R/WC	R/WC	2	UInt32	Second	Dropout Time Delay
14153	R/WC	R/WC	1	Bitmap	–	Digital Outputs to Associate
Over Power, Total Active						Alarm ID = 9
14165	R/WC	R/WC	2	Float32	kW	Pickup Setpoint
14167	R/WC	R/WC	2	UInt32	Second	Pickup Time Delay
14169	R/WC	R/WC	2	Float32	%	Dropout Setpoint
14171	R/WC	R/WC	2	UInt32	Second	Dropout Time Delay
14173	R/WC	R/WC	1	Bitmap	–	Digital Outputs to Associate
Over Power, Total Reactive						Alarm ID = 10
14185	–	R/WC	2	Float32	kVAR	Pickup Setpoint
14187	–	R/WC	2	UInt32	Second	Pickup Time Delay
14189	–	R/WC	2	Float32	%	Dropout Setpoint
14191	–	R/WC	2	UInt32	Second	Dropout Time Delay
14193	–	R/WC	1	Bitmap	–	Digital Outputs to Associate
Over Power, Total Apparent						Alarm ID = 11
14205	R/WC	R/WC	2	Float32	kVA	Pickup Setpoint
14207	R/WC	R/WC	2	UInt32	Second	Pickup Time Delay
14209	R/WC	R/WC	2	Float32	%	Dropout Setpoint

Register Address	Action (R/W/WC)		Size	Type	Units	Description
	PM3250	PM3255				
14211	R/WC	R/WC	2	UInt32	Second	Dropout Time Delay
14213	R/WC	R/WC	1	Bitmap	–	Digital Outputs to Associate
Leading Power Factor, Total						Alarm ID = 12
14225	–	R/WC	2	Float32	–	Pickup Setpoint
14227	–	R/WC	2	UInt32	Second	Pickup Time Delay
14229	–	R/WC	2	Float32	%	Dropout Setpoint
14231	–	R/WC	2	UInt32	Second	Dropout Time Delay
14233	–	R/WC	1	Bitmap	–	Digital Outputs to Associate
Lagging Power Factor, Total						Alarm ID = 13
14245	–	R/WC	2	Float32	–	Pickup Setpoint
14247	–	R/WC	2	UInt32	Second	Pickup Time Delay
14249	–	R/WC	2	Float32	%	Dropout Setpoint
14251	–	R/WC	2	UInt32	Second	Dropout Time Delay
14253	–	R/WC	1	Bitmap	–	Digital Outputs to Associate
Over Demand, Total Active Power, Present						Alarm ID = 16
14305	–	R/WC	2	Float32	kW	Pickup Setpoint
14307	–	R/WC	2	UInt32	Second	Pickup Time Delay
14309	–	R/WC	2	Float32	%	Dropout Setpoint
14311	–	R/WC	2	UInt32	Second	Dropout Time Delay
14313	–	R/WC	1	Bitmap	–	Digital Outputs to Associate
Over Demand, Total Apparent Power, Present						Alarm ID = 22
14425	–	R/WC	2	Float32	kVA	Pickup Setpoint
14427	–	R/WC	2	UInt32	Second	Pickup Time Delay
14429	–	R/WC	2	Float32	%	Dropout Setpoint
14431	–	R/WC	2	UInt32	Second	Dropout Time Delay
14433	–	R/WC	1	Bitmap	–	Digital Outputs to Associate
Over THD-U, Phase						Alarm ID = 28
14545	–	R/WC	2	Float32	%	Pickup Setpoint
14547	–	R/WC	2	UInt32	Second	Pickup Time Delay
14549	–	R/WC	2	Float32	%	Dropout Setpoint
14551	–	R/WC	2	UInt32	Second	Dropout Time Delay
14553	–	R/WC	1	Bitmap	–	Digital Outputs to Associate
Under Power, Total Active						Alarm ID = 30
14825	R/WC	R/WC	2	Float32	kW	Pickup Setpoint
14827	R/WC	R/WC	2	UInt32	Second	Pickup Time Delay
14829	R/WC	R/WC	2	Float32	%	Dropout Setpoint
14831	R/WC	R/WC	2	UInt32	Second	Dropout Time Delay
14833	R/WC	R/WC	1	Bitmap	–	Digital Outputs to Associate
Over THD-I, Phase						Alarm ID = 31
14865	–	–	2	Float32	%	Pickup Setpoint
14867	–	R/WC	2	UInt32	Second	Pickup Time Delay
14869	–	R/WC	2	Float32	%	Dropout Setpoint
14871	–	R/WC	2	UInt32	Second	Dropout Time Delay
14873	–	R/WC	1	Bitmap	–	Digital Outputs to Associate
Over THD-V, Phase						Alarm ID = 32
14905	–	R/WC	2	Float32	%	Pickup Setpoint
14907	–	R/WC	2	UInt32	Second	Pickup Time Delay
14909	–	R/WC	2	Float32	%	Dropout Setpoint
14911	–	R/WC	2	UInt32	Second	Dropout Time Delay
14913	–	R/WC	1	Bitmap	–	Digital Outputs to Associate

Register Address	Action (R/W/WC)		Size	Type	Units	Description
	PM3250	PM3255				
<b>1-Second Alarms - Custom</b>						
Over Energy, Total Active					Alarm ID = 41	
14942	–	R/WC	2	UInt16	–	Source Register: ENERGY_LOG_DAY_REALTIME_VALUE: 41504 ENERGY_LOG_WEEK_REALTIME_VALUE: 41874 ENERGY_LOG_MONTH_REALTIME_VALUE: 42043
14945	–	R/WC	2	Float32	Wh	Pickup Setpoint
14947	–	R/WC	2	UInt32	Second	Pickup Time Delay
14949	–	R/WC	2	Float32	%	Dropout Setpoint
14951	–	R/WC	2	UInt32	Second	Dropout Time Delay
14953	–	R/WC	1	Bitmap	–	Digital Outputs to Associate

## Energy Log

Register Address	Action (R/W/WC)		Size	Type	Units	Description
	PM3250	PM3255				
<b>Energy Log - Day</b>						
45600	–	R	1	UInt16	–	Enable/Disable: 0x0000 = Disable 0xFFFF = Enable
45601	–	R	1	UInt16	–	Maximum Entry Number
45602	–	R	1	UInt16	–	Current Entry Number
45603	–	R	1	UInt16	–	Latest Entry ID
45604	–	R	1	UInt16	–	Oldest Entry ID
45605	–	R	4	Int64	Wh	Real-time Value of Current Day
45609	–	R	4	Date/Time	–	Entry 001 Date/Time
45613	–	R	4	Int64	Wh	Entry 001 Value
45961	–	R	4	Date/Time	–	Entry 045 Date/Time
45965	–	R	4	Int64	Wh	Entry 045 Value
<b>Energy Log - Week</b>						
45969	–	R	1	UInt16	–	Enable/Disable: 0x0000 = Disable 0xFFFF = Enable
45970	–	R	1	UInt16	–	Maximum Entry Number
45971	–	R	1	UInt16	–	Current Entry Number
45972	–	R	1	UInt16	–	Latest Entry ID
45973	–	R	1	UInt16	–	Oldest Entry ID
45974	–	R	4	Int64	Wh	Real-time Value of Current Day
45978	–	R	4	Date/Time	–	Entry 001 Date/Time
45982	–	R	4	Int64	Wh	Entry 001 Value
46130	–	R	4	Date/Time	–	Entry 020 Date/Time
46134	–	R	4	Int64	Wh	Entry 020 Value
<b>Energy Log - Month</b>						
46138	–	R	1	UInt16	–	Enable/Disable: 0x0000 = Disable 0xFFFF = Enable
46139	–	R	1	UInt16	–	Maximum Entry Number
46140	–	R	1	UInt16	–	Current Entry Number
46141	–	R	1	UInt16	–	Latest Entry ID
46142	–	R	1	UInt16	–	Oldest Entry ID
46143	–	R	4	Int64	Wh	Real-time Value of Current Day

Register Address	Action (R/W/WC)		Size	Type	Units	Description
	PM3250	PM3255				
46147	–	R	4	Date/Time	–	Entry 001 Date/Time
46151	–	R	4	Int64	Wh	Entry 001 Value
46243	–	R	4	Date/Time	–	Entry 013 Date/Time
46247	–	R	4	Int64	Wh	Entry 013 Value



## 5.5 Read Device Identification

### Register List

#### Read Device Identification

The power meter supports the Basic Device Identification with the mandatory objects:

- VendorName
- ProductCode
- Revision Number

ObjectID	Object Name/Description	Object Length	Object Value	Note
0x00	VendorName	16	SchneiderElectric	–
0x01	ProductCode	11	METSEPM3200 METSEPM3210 METSEPM3250 METSEPM3255	The ProductCode is identical to the catalogue number of each reference
0x02	MajorMinorRevision	04	V1.0	Equivalent to X.Y in register 1637

The Read Device ID code 01 and 04 are supported:

- 01 = request to get the basic device identification (stream access)
- 04 = request to get one specific identification objective (individual access)

The Modbus request and response are compliant with “Chapter 6.20 43 / 14 (0x2B / 0x0E) Read Device Identification” of Modbus Application Protocol Specification.



# Technical Characteristics

# 6

## Specifications

### Electrical Characteristics

Characteristic		Value	Power Meters
Measured voltage input	Direct/VT secondary	50...330 V AC (Ph-N) 80...570 V AC (Ph-Ph)	PM32**
	With external VT	VT primary up to 1 MV AC	
	Frequency range	45...65 Hz	
Measured current input	CT primary	Adjustable from 1 A to 32767 A	PM32**
	CT secondary	1 A or 5 A	
	Permissible overload	10 A continuous, 20 A for 10 s/hour	
Control power		100/173...277/480 V AC ( $\pm 20\%$ ), 45...65 Hz, 3 W/5 VA, 100...300 V DC, 3 W	PM32**
Two solid state relay digital outputs	Voltage	5...40 V DC	PM3255
	Current	50 mA maximum	
	Output resistance	50 Ohm maximum	
	Isolation	3.5 kV	
One optical coupler output for remote transfer	Voltage	5...30 V DC	PM3210
	Current	1...15 mA	
	Pulses/kWh	Configurable	
	Pulse width	Minimum width is 50 millisecond	
	Isolation	3.5 kV	
	Standard	IEC 62053-31 compatible (S0 format output)	
Two digital inputs	Voltage off	0...5 V DC	PM3255
	Voltage on	11...40 V DC, 24 V DC nominal	
	Current	< 4 mA max. burden	
	Isolation	3.5 kV	
	Standard	IEC61131-2 compatible (TYPE 1)	
Internal clock	Time error	< 2.5 s/day (30 ppm) at 25° C	PM32**
	Backup time	> 5 minutes	

### Measurement Accuracy

Performance Standard	
	IEC61557-12 PMD/Sx/K55/0.5 (x 5 A CT)
	IEC61557-12 PMD/Sx/K55/1 (x 1 A CT)

Measurement quantity	Accuracy
Current with x/5 A CTs	0.3%, 0.5...6 A
Current with x/1 A CTs	0.5%, 0.1...1.2 A
Voltage	0.3%, 50...330 V (Ph-N) 80...570 V (Ph-Ph)
Power factor	$\pm 0.005$ , 0.5 A...6 A with x/5A CTs 0.1...1.2 A with x/1A CTs; 0.5 L ...0.8 C

Measurement quantity	Accuracy
Active/Apparent power with x/ 5 A CTs	Class 0.5
Active/Apparent power with x/ 1 A CTs	Class 1
Reactive power	Class 2
Frequency	0.05%, 45...65 Hz
Active energy with x/5 A CTs	IEC62053-22 Class 0.5s
Active energy with x/1 A CTs	IEC62053-21 Class 1
Reactive energy	IEC62053-23 Class 2

### Mechanical Characteristics

Characteristic		Value	Power Meters
Weight		0.26 kg	PM32••
IP degree of protection	Front panel	IP40	PM32••
	Casing	IP20	
Recommended terminal tightening torque	Control power	6 mm <sup>2</sup> / 0.8 N.m	PM32••
	Voltage input	2.5 mm <sup>2</sup> / 0.5 N.m	PM32••
	Current input	6 mm <sup>2</sup> / 0.8 N.m	PM32••
	Pulse output	2.5 mm <sup>2</sup> / 0.5 N.m	PM3210
	Digital inputs/outputs	1.5 mm <sup>2</sup> / 0.5 N.m	PM3255
	RS-485	2.5 mm <sup>2</sup> / 0.5 N.m	PM325•

### Other Characteristics

Characteristic		Value
Operating temperature		-25° C...+55° C (K55)
Storage temperature		-40° C...+85° C (K55)
Humidity rating		5 to 95% RH at 50° C (non-condensing)
Pollution degree		2
Overvoltage and measurement category		III
Electromagnetic compatibility	Electrostatic discharge	Level IV (IEC61000-4-2)
	Immunity to radiated fields	Level III (IEC61000-4-3)
	Immunity to fast transients	Level IV (IEC61000-4-4)
	Immunity to surge	Level IV (IEC61000-4-5)
	Conducted immunity	Level III (IEC61000-4-6)
	Immunity to power frequency magnetic fields	0.5 mT (IEC61000-4-8)
	Conducted and radiated emissions	Class B (EN55022)
Safety		CE as per IEC61010-1
Meter indicator		5000 flashes / kWh without consideration of transformer ratios
Data update rate		1 second
Communication	RS-485 port (PM325•)	Half duplex, from 9600 up to 38 400 bauds, Modbus RTU (double insulation)
Display characteristics	Dimensions (VA)	43 mm x 34.6 mm
	Display resolution	128 x 96 dots
Standard compliance		IEC61557-12, EN61557-12 IEC61010-1, UL61010-1 IEC62053-11, IEC62053-21, IEC62053-22, IEC62053-23 EN50470-1, EN50470-3

---

# Maintenance and Troubleshooting



---

## What Is in This Chapter?

This chapter contains the following topics:

Topic	Page
Safety Precautions	94
Password Recovery	95
Language Download	96
Troubleshooting	97

## Safety Precautions

### Presentation

The following safety precautions must be thoroughly implemented before attempting to repair electrical equipment or carry out maintenance. Carefully read and follow the safety precautions described below.

### **DANGER**

#### **RISK OF ELECTRIC SHOCK, ARC FLASH OR BURNS**

- Wear suitable personal protective equipment and follow the currently applicable electrical safety instructions. See, for example, standard NFPA 70E when carrying out work in the USA.
- Only qualified personnel should maintain this equipment. Such work should be performed only after reading all the installation instructions.
- Turn off all power supplying this equipment before working on or inside it.
- NEVER work alone.
- Beware of potential hazards and wear personal protective equipment.

**Failure to follow these instructions will result in death or serious injury.**

### **NOTICE**

#### **RISK OF DAMAGE TO THE POWER METER**

- Never open the power meter unit.
- Do not attempt to repair any components in the power meter range, either in the unit or an accessory.

**Failure to follow these instructions can result in equipment damage.**

## Password Recovery

If you forget your password, contact Schneider Electric service or send an email to [Global-PMC-Tech-support@schneider-electric.com](mailto:Global-PMC-Tech-support@schneider-electric.com) for password recovery assistance.

Technical support provides you a new password based on the serial number of your power meter.

**NOTE:** Make sure that you include serial number of your power meter in your e-mail or have it readily available when you call technical support.

## Language Download

The power meter supports the downloading of new language files over the communications link. This action requires the free DLF3000 software, which is available at [www.schneider-electric.com](http://www.schneider-electric.com). The DLF3000 offers an extensive Help file with information on operating the software. The most recent language files are also available on the website.



## Troubleshooting

The combination of the backlight and the symbol  helps you to troubleshoot the power meter. Refer to Status Information (*see page 42*) for more details.

If the combination of the backlight and the symbol  indicates an active diagnosis, refer to Operation (*see page 41*) to get the diagnosis code.

Diagnostic code	PM3200	PM3210	PM3250	PM3255	Description	Possible solution
–	√	√	√	√	LCD display is not visible.	Check and adjust LCD contrast/backlight settings or contact Schneider Electric service.
–	√	√	√	√	Push button failure.	Restart the power meter by power off and power on again. If there is still no response, contact Schneider Electric service.
101, 102	√	√	√	√	Metering stops due to internal error. Total energy consumption is displayed.	Enter the Configuration mode and implement <b>Reset Config</b> or contact Schneider Electric service.
201	√	√	√	√	Metering continues. Mismatch between frequency settings and frequency measurements.	Correct frequency settings according to the nominal frequency of the network.
202	√	√	√	√	Metering continues. Mismatch between wiring settings and wiring inputs.	Correct wiring settings according to wiring inputs.
203	√	√	√	√	Metering continues. Phase sequence reverse.	Check wire connections or correct wiring settings.
205	√	√	√	√	Metering continues. Date and Time are reset due to last power failure.	Set Date and Time.
206	–	√	–	√	Metering continues. Pulse missing due to overspeed of energy pulse output or yellow meter indicator.	Set the suitable parameters of the energy pulse output. Correct the mistakes in meter configuration. For example, choose x/1A range for 5 A input. Make sure there is no current overload.
207	√	√	√	√	Metering continues. Abnormal internal clock function.	Restart the power meter by power off and power on again. If there is still no response, contact Schneider Electric service.

The power meter does not contain any user-serviceable parts. If the power meter requires service, contact your local sales representative. Do not open the power meter. Opening the power meter voids the warranty.



---

# Appendices



---

## What Is in This Appendix?

The appendix contains the following chapters:

Chapter	Chapter Name	Page
A	Power Factor Register Format	101
B	Abbreviations and Symbols	103



# Power Factor Register Format



## Register Format in Power Factor

Each power factor (PF) value occupies 1 floating point register. The power meter display interprets the register format according to the PQS Coordinate System chart. The PQS Coordinate System chart uses the power factor register value to provide information on leading or lagging power factor and current, and also energy import or export.

- Power Factor (PF): Difference between the total power and the portion of total power that does the useful work. The ratio of Active (P) power to Apparent (S) power (kW/kVA).
- True Power Factor: Includes harmonic content.
- Leading PF: Active (P) and Reactive (Q) power are flowing in opposite directions.
- Lagging PF: Active (P) and Reactive (Q) power are flowing in same directions.
- Leading Current (I): Current is leading voltage up to  $180^\circ$ .
- Lagging Current (I): Current is lagging voltage up to  $180^\circ$ .

The PQS Coordinate System chart quadrants are based on the IEC convention.

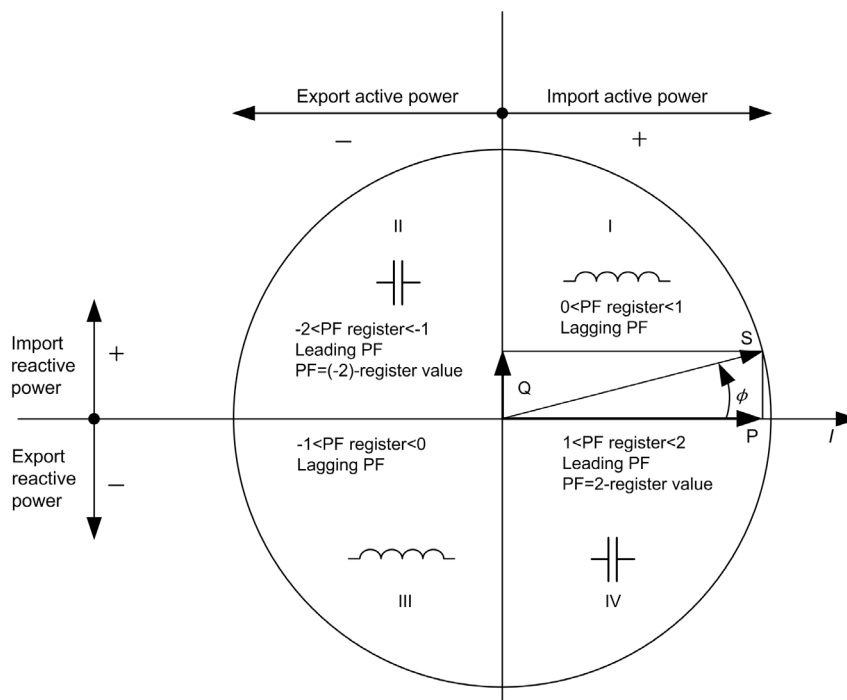

**Determining a Power Factor**

To determine a power factor, proceed as follows:

Step	Action
1	Get the register value.
2	Use the register value to determine in which quadrant the system is operating. <b>NOTE:</b> The quadrant determines lead/lag for power factor and current.
3	Use the register value to determine the flow of active power: <ul style="list-style-type: none"> <li>● A positive value indicates active/apparent energy import.</li> <li>● A negative value indicates active/apparent energy export.</li> </ul>
4	Use the register value to determine the flow of reactive power: <ul style="list-style-type: none"> <li>● <math>-2 &lt; \text{PF register} &lt; -1</math>, <math>0 &lt; \text{PF register} &lt; 1</math> indicates reactive energy import.</li> <li>● <math>-1 &lt; \text{PF register} &lt; 0</math>, <math>1 &lt; \text{PF register} &lt; 2</math> indicates reactive energy export.</li> </ul>
5	Use the register value to determine power factor: <ul style="list-style-type: none"> <li>● If the register value is within -1 to +1, the register value is the power factor value.</li> <li>● If the register value is within -1 to +1, the power factor value is derived differently for active energy import and active energy export systems: <ul style="list-style-type: none"> <li>● for active energy import: <math>\text{PF} = 2 - (\text{the register value})</math></li> <li>● for active energy export: <math>\text{PF} = -2 - (\text{the register value})</math></li> </ul> </li> </ul> <p>For example:</p> <ul style="list-style-type: none"> <li>● Register value = 0.999: Apparent power is in quadrant 1, current (I) is lagging, and active energy is imported to the customer load with a lagging power factor of 0.999.</li> <li>● Register value = -1.1: Apparent power is in quadrant 2, current (I) is lagging, and active energy is exported by the customer load with a leading power factor of -0.9 (<math>\text{PF} = (-2) - (-1.1)</math>).</li> <li>● Register value = -0.986: Apparent power is in quadrant 3, current (I) is leading, and active energy is exported by the customer load with a lagging power factor of 0.986.</li> <li>● Register value = 1.14: Apparent power is quadrant 4, current (I) is leading, and active energy is imported to the customer with a leading power factor of 0.86 (<math>\text{PF} = 2 - 1.14</math>).</li> </ul>

---

## Abbreviations and Symbols



---

### Abbreviations and Symbols

Abbreviations/Symbols	Description
Comon	Common
Dfault	Default
DMD	Demand
DMDPk	Peak Demand
Ea	Active Energy
Er	Reactive Energy
Eap	Apparent Energy
Epart	Partial Energy (including Partial Energy Import, Energy by Tariff, and Phase Energy)
HiMax	The highest of the 3-phase maximum value. For example, I1 max. = 10 A, I2 max. = 2 A, I3 max. = 8 A. HiMax (of I) = 10 A
LangDL	Language download
LoMin	The lowest of the 3-phase maximum value. For example, I1 min. = 3 A, I2 min. = 2 A, I3 min. = 1 A. LoMin (of I) = 1 A
MnMx	Minimum, Maximum
Oper	Operation
Pk1DT	Phase 1 Peak Demand Time
PknDT	Neutral Peak Demand Time
PFLed	Power Factor Leading
PFLag	Power Factor Lagging
PWD	Password
TgPhi	Tangent Phi (the reactive factor)
THDU	Total Harmonic Distortion L-L Voltage
THDV	Total Harmonic Distortion L-N Voltage
THDI	Total Harmonic Distortion Current
Uubl	L-L voltage unbalance
Vubl	L-N voltage unbalance
Ver	Version
WAGES	Water, Air, Gas, Electric, Steam













**DOCA0006EN-01**

**Schneider Electric Industries SAS**

35, rue Joseph Monier

CS30323

F - 92506 Rueil Malmaison Cedex

[www.schneider-electric.com](http://www.schneider-electric.com)

*As standards, specifications and designs change from time to time, please ask for confirmation of the information given in this publication.*

06/2012