

User manual

ADA-401W

RS-422 to 1-WIRE Converter



Contents

1. GENERAL INFORMATION.....	3
1.1. WARRANTED INFORMATION	3
1.2. GENERAL CONDITIONS FOR SAFE USE.....	3
1.3. CE LABEL.....	3
1.4. ENVIRONMENTAL PRESERVATION.....	3
1.5. SERVICE AND MAINTENANCE.....	3
2. PRODUCT INFORMATION.....	3
2.1. PROPERTIES.....	3
2.2. DESCRIPTION.....	4
2.3. APPLICATION.....	4
2.4. EPROM MEMORY PROGRAMMING.....	4
2.5. CONVERSION OF 1-WIRE TO RS-422 STANDARDS.....	5
2.6. ISOLATION.....	5
3. INSTALLATION.....	5
3.1. ASSEMBLING.....	5
3.2. CONNECTION TO PC.....	5
3.2.1. LINE TERMINATION.....	6
3.3. CONNECTION TO 1-WIRE NETWORK	6
3.3.1. CONNECTION 1-WIRE SENSORS.....	6
3.3.2. LIMITATIONS OF 1-WIRE BUS.....	6
3.4. POWER SUPPLY.....	7
4. STARTUP.....	7
4.1. SIGNALING LEADS.....	7
5. VERSIONS.....	7
6. SPECIFICATION.....	7

1. GENERAL INFORMATION

Thank you for your purchase of **CEL-MAR Company** product. This product has been completely tested and is covered by a two year warranty on parts and operation from date of sale.

If any questions or problems arise during installation or use of this product, please do not hesitate to contact Technical Support at +48 41 362-12-46 or e-mail support@cel-mar.pl.

1.1. WARRANTED INFORMATION

CEL-MAR Company gives the indefinite guarantee on the **ADA-401W converter**. The warranty does not cover damage caused from improper use, materials consumption or any unauthorized changes. If the product does not function accordance with the instructions will be repaired. All warranty and no warranty repairs must be returned with paid transport and insuring to the **CEL-MAR Company**.

CEL-MAR Company under no circumstances won't be responsible for ensuing damage from improper using the product or as a result of random causes: the lightning discharge, the flood, the fire and the like.

CEL-MAR Company is not be held responsible for damages and loss including: loss of profits, loss of data, pecuniary losses ensuing from using or the impossibility of using this product.

In specific cases CEL-MAR Company discontinue all warranties and in particular do not follow the user manual and do not accept terms of warranty by the user.

1.2. GENERAL CONDITIONS FOR SAFE USE

The device should be installed in a safe and stable places (eg, electroinstallation cabinet), the powering cable should be arranged so as not to be exposed to trampling, attaching, or pulling out of the circuit.

Do not put device on the wet surface.

Do not connect devices for nondescript powering sources,

Do not damage or crush powering wires.

Do not make connection with wet hands.

Do not adapt, open or make holes in casings of the device!

Do not immerse device in water or no other liquid.

Do not put the fire opened on device sources: candles, an oil lamps and the like.

Complete disable from the supply network is only after disconnecting the power supply circuit voltage.

Do not carry out the assembly or disassembly of the device if it is enabled. This may result to short circuit and damage the device.

1.3. CE LABEL



CE symbol on organizing the company CEL-MAR a conformity of the device to the directive of the electromagnetic EMC 89/336/EWG compatibility means (Electromagnetic Compatibility Directive). The declaration of the agreement is accessible through the contact with the technical service at the address e-mail: support@cel-mar.pl or on the phone at the +48 41 362-12-46.



1.4. ENVIRONMENTAL PRESERVATION

This sign on the device inform about putting expended device with other waste materials. Device should send to the recycling. (In accordance with the act about the Electronic Appliance Expended from day 29 of July 2005)

1.5. SERVICE AND MAINTENANCE

The **ADA-401W converter** does not require the servicing and maintenance.

Technical support is available at number +48 41 362-12-46 in 8.00-16.00, from Monday to Friday or e-mail support@cel-mar.pl.

2. PRODUCT INFORMATION

Module is delivered with: User Manual, resistors: $R_t=120\Omega$ (2 pcs.).

2.1. PROPERTIES

- RS-422 conversion to 1-WIRE,
- Converted signals: RX, TX,
- Possibility of operating on MicroLAN bus,
- Possibility of programming EPROM memory on the 1-WIRE bus (version device -2-x-x),
- Baud rate of RS-422 bus [kbit/sec]: 9.6, 19.2, 57.6, 115.2,
- Standard baud rate of 1-WIRE bus up to 16.3 kbps,
- Overdrive baud rate of 1-WIRE bus up to 142 kbps,
- External power supply 10 - 30 VDC stable with power min. 3W,
- 1kV= or 3kV= galvanic isolation between RS-422 interface and power supply,
- 3kV= optoisolation in signal channel between RS-422 and 1-WIRE interface,
- Casing compatible with DIN 43880 standard– mounting in typical electro-installation unit,
- Casing adapt to rail mounting according to Dinas EN 50022 standard,
- Casing dimensions (W x H x L) 53mm x 90mm x 58mm,
- Connection RS-422 interface via screw terminal block,
- Connecting 1-WIRE bus and power supply via screw terminal block,
- Implemented short circuit protection and over-voltage protection on RS-422 interface line,
- Implemented protection against power supply reverse connection,

2.2. DESCRIPTION

The **ADA-401W** industrial converter for general use, allows connection several circuits with 1-Wire interface, such as temperature measurement systems, real time clocks, EPROM, A/C, etc. to a common 1-Wire bus far away from the Master device (up to 1200m). The transition from the 1-Wire interface to RS-422 interface on ADA-401W, provides system DS2480B and level converter TTL to RS-422. This relieves the user from having to be in a quite a complicated 1-Wire protocol.

The using of an additional converter RS-422 to RS-232 (eg, ADA-1040) allows monitoring and / or control systems 1-Wire via RS-232 interface on a PC equipped with the appropriate software. **CEL-MAR** provides sample applications for the visualization of temperature measurement named **Lämpömittari** by **Timo Sara-aho**. The program works with systems to measure temperature eg **DS18S20**. In the configuration settings of **Lämpömittari** the section **MicroLAN** use the symbol **DS9097U** adapter.

ADA-401W is equipped with screw terminal block for twisted connections of 1-Wire bus and RS-422 and for power supply. Over-voltage protection on each RS-422 line was made on base over-voltage LEDs and fuses.

ADA-401W is designed for power from an external DC voltage source whose value should be in the range of 10V to 30V and it was supplied from the AC power 3W min. It also has built-in protection against reverse polarity power supply.

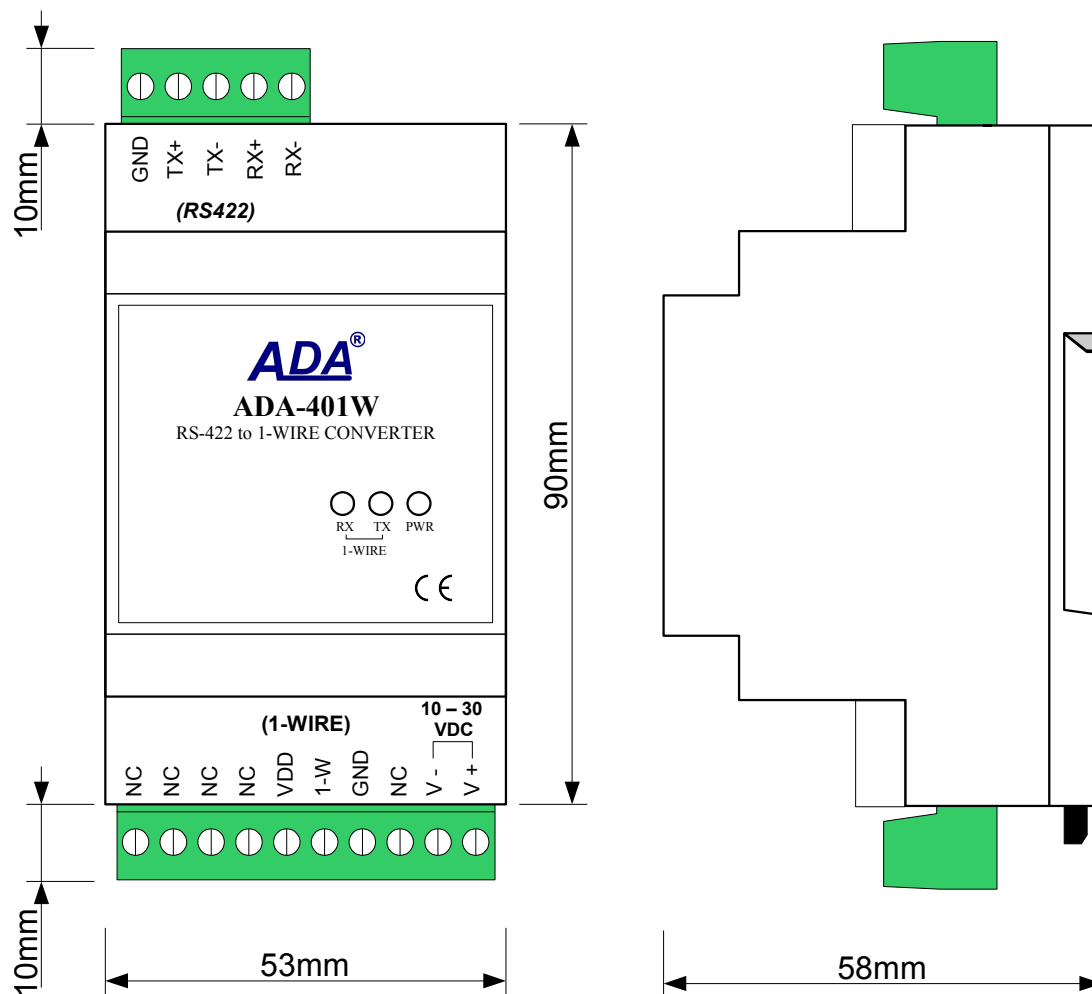

Fig. 1. ADA-401W view

2.3. APPLICATION

ADA-401W converter can be used in all kind of local systems based on MicroLAN networks such as: the registration of the temperature, the monitored access, steering the functioning of air-conditionings of both the heating, the remote control and the supervision, in alarm, fire systems and the like much moved away from monitoring center. A market of alarm systems is one of most quickly developing at present markets, which MicroLAN is being used among others for linking in of sensors with the alarm head office, where in place a few or of a dozen or so wires will only be enough 3. In such applying does MicroLAN prevent the possibility of cheating through clenching or incising the line and at the same time provides with the alarm system easiness of the automatic configuration and the reconfiguration of the alarm system during the work. Much also leading test procedures which disabled elements of the system are helping to eliminate is simpler than in standard solutions.

2.4. EPROM MEMORY PROGRAMMING

ADA-401W converter in version 2-x-x allows to programming EPROM memory added to MicroLAN network. It is done by the use of micro-switch on the front panel. By setting the micro-switch to PROG position, to the bus should be added programmable circuit and make the programming. If on the bus are circuits which do not require programming, the micro-switch should be set to NORMAL position.

2.5. CONVERSION OF 1-WIRE TO RS-422 STANDARDS

Because of the fairly complex 1-WIRE protocol, ADA-401W converter is equipped with DS2480B circuit, which make easy access to 1-WIRE from a serial RS-422 bus. Communication with device connected to 1-WIRE is sending/receiving the appropriate command via RS422 interface. Additional description all commands and communication are described in technical documentation DS2480B circuit, available on manufacturer web page http://www.maxim-ic.com/quick_view2.cfm/qv_pk/2923 or [CEL-MAR](#).

2.6. ISOLATION

Converter ADA-401W has 2-way, 1kV= or 3kV= galvanic isolation (depend on version, described in section VERSIONS).

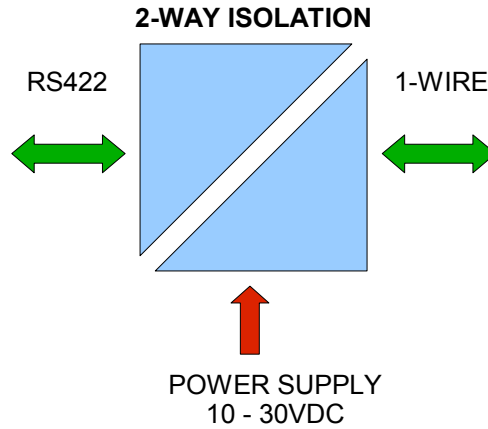

Fig. 2. Isolation diagram

3. INSTALLATION

This chapter will show how to connect ADA-401W to PC, 422 bus, 1-WIRE line and power supply and how to use it. To reduce disturbance from environment, it is recommended to:

- use multipair type shielded cables, which shield can be connected to the earthing on one end of the cable,
- use the suitable diameter cable for power supply on account of voltage drop,
- use the powering cable with a suitable section because of the voltage drops,
- use the interference eliminators for powering the converter,
- lay signal cables at a distance of not less than 25 cm away from power cables,
- not powering the converters form the power-circuit of devices generate large impulse disturbance like contactors, relays, inverters.

3.1. ASSEMBLING

ADA-401W converter case is adapted to assembly on TS-35 (DIN35) rail. To install converter should mount device on the rail upper part of the case then press bottom part to to hearing characteristic „Click” sound.

3.2. CONNECTION TO PC

ADA-401W can be connected to RS232 port or USB of PC by the use of additional converter eg. RS232 to RS485/422 (ADA-1040) or USB to RS485/422 (ADA-I9140). The connection is made via RS422 bus, as on the figure below.

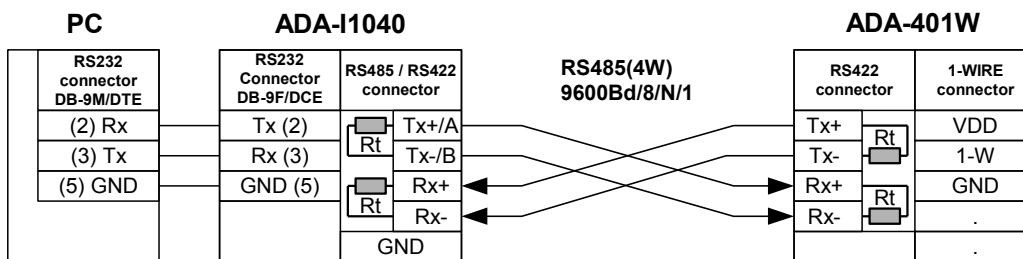

Fig. 3. 4-wire connection of ADA-401W to PC by the use of RS232 to RS485/RS422 converter ADA-I1040

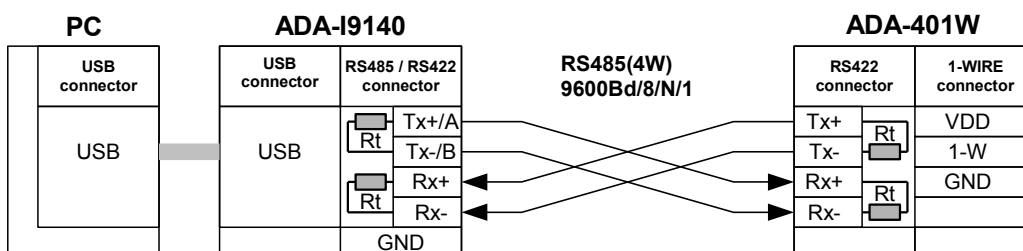

Fig. 4. 4-wire connection of ADA-401W to PC by the use of USB to RS485/RS422 converter ADA-I9140

3.2.1. LINE TERMINATION

The application of Line Termination (terminator) $R_t = 120 \Omega$ (ohms) will reduce electrical reflection in data line at high baud rate. It is not needed below 9600Bd. The Line Termination resistor should be used if the distance is over 1000m @ 9600Bd or 700m @ 19200Bd transmission, the resistor can be necessary if there are problems with the transmission correctness. Example connection of R_t to screw terminal block of RS422 interface ADA-401W are shown on Fig. 3 & 4.

3.3. CONNECTION TO 1-WIRE NETWORK

3.3.1. CONNECTION 1-WIRE SENSORS

Way to link temperature sensor to ADA-401W converter is shown on figure below.

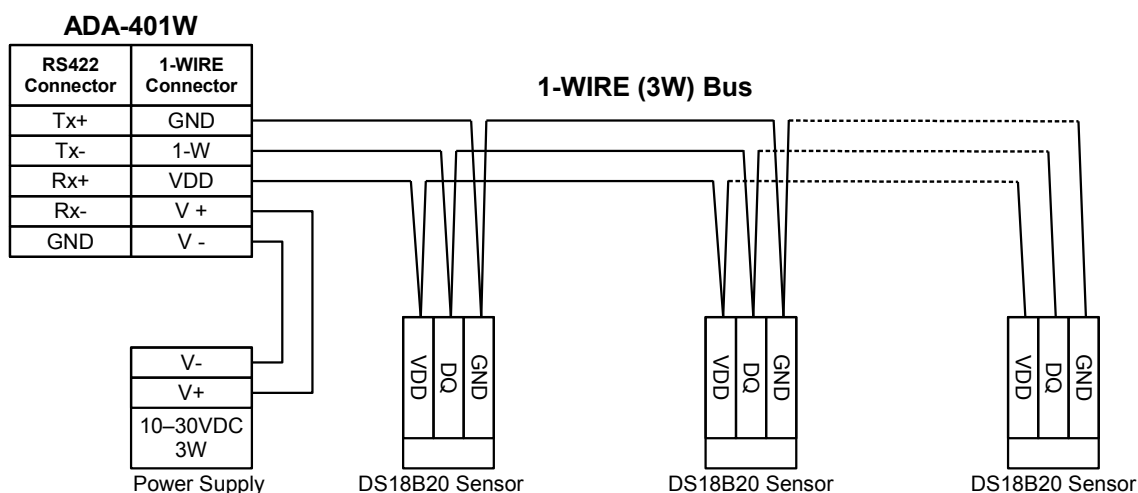

Fig. 5. Sensor connection to ADA-401W converter by 3-wire 1-WIRE Bus

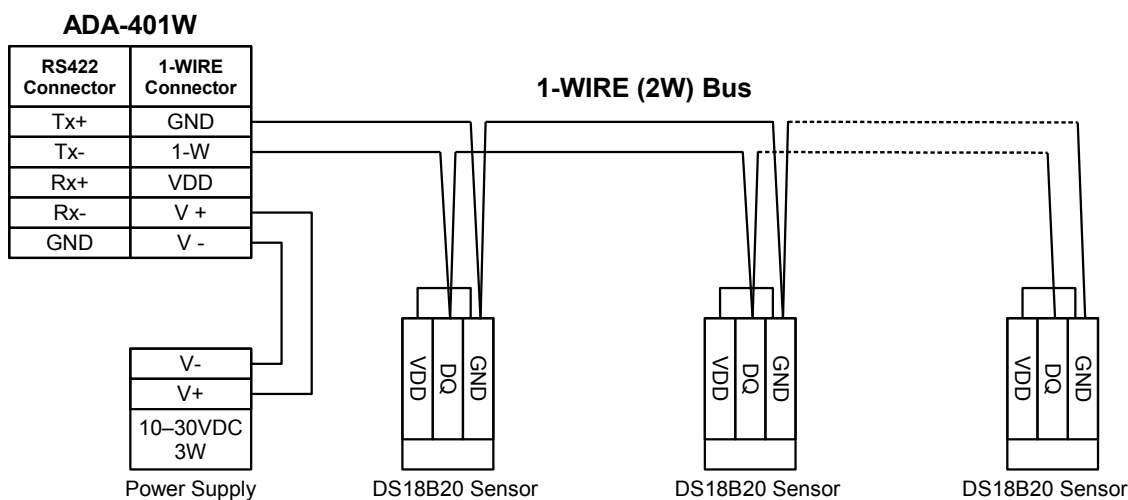

Fig. 6. Sensor connection to ADA-401W converter by 2-wire 1-WIRE Bus

3.3.2. LIMITATIONS OF 1-WIRE BUS

The maximum length of 1-wire bus as layouts producer can be even 400m and the maximum number of sensors can be 500. However, when building the bus, remember that, each sensor is a shortening of 0,5 meters and 100 meters of cable causes additional capacity load data line 5nF increasing signal distortion.

1-WIRE bus length and number of sensors will be less and will depend on:

- used cables,
- topology connection,
- quality implementation of connections,
- interference from external electromagnetic fields.

RECOMMENDS:

- application of twisted cables UTP 4x2x0,5,
- powered converter with an individual power supply with good parameters, eg. DR-15-24,
- linear topology of 1-WIRE bus (sensors in a star topology can be converted to linear topology by using Passive 1-WIRE Bus Splitter ADA-DNB400),
- finishing 1-WIRE bus by sensor,
- connecting unused wires and screen cable to rail PE of electrical installation.

3.4. POWER SUPPLY

The power supply to ADA-40WA should be DC (regulated) from the scope 10 V= to 30V= and nominal power more then 3W eg. DR-15-25 or ZS-12/500. The power cable from DC power supplies to the device must not be longer than 3m. Observe the polarity, connect positive (+) of DC power supplies to V + and negative (-) end to V - terminal.

4. STARTUP

Converter can be powered after proper connection according to steps above. If connection was made properly green LED PWR on front panel of converter should light, if not check correctness of power connection. ADA401W has the protection against power supply reverse connection. During correctness data transition via the converter the LEDs Tx and Rx should blinking.

4.1. SIGNALING LEDES

LED	Description
PWR	Signalling of Power Supply
TX	Signalling of data transmitting through 1-WIRE interface
RX	Signalling of data receiving from 1-WIRE 1-WIRE interface

ATTENTION!

At baud rate above 19200 bps the LED's Tx, Rx will light weakly during data transmission.

5. VERSIONS

ADA-401W -		
Electronic versions:		
Without possibility of programming 1-WIRE interface	1	
With possibility of programming 1-WIRE interface	2	
Galvanic isolation:		
1kV=	2	
3kV=	3	
Terminal & Terminal Cover:		
Cover without inlets, screw terminal block		1
Cover with inlets, screw terminal block		2
Cover without inlets, plug-in screw terminal block		3

Order example:

Product Symbol: **ADA-401W-1-2-3**

1 – without possibility of programming 1-WIRE interface,

2 – galvanic isolation 1kV=,

3 – cover without inlets, plug-in screw terminal block,

6. SPECIFICATION

Transition Parameters		
Interface	RS-422	1-WIRE
Connector	screw terminal, wire max. \varnothing 2,5mm ²	screw terminal, wire max. \varnothing 2,5mm ²
Line length	1200m	up to 400m – for ds18b20 sensors
Maximum number of connected device	1	100
Transmission line	Twisted cable 2-pair , UTP Nx2x0,5 (24AWG), shield inside large interferences STP Nx2x0,5(24AWG).	Twisted cable 1-pair or 2-pair , UTP Nx2x0,5 (24AWG), shield inside large interferences STP Nx2x0,5(24AWG).
Maximum baud rate	9.6, 19.2, 57.6, 115.2	standard: 0 do 16,3 kbps, overdrive: 0 do 142 kbps,
Transmission type	1-WIRE - half duplex (sending and receiving on the same wire)	
Standards	1-WIRE – TTL signal, EIA-422, CCITT V.11.	
Optical signaling	<ul style="list-style-type: none"> • PWR – green LED power supply • RX - red LED data receiving through 1-WIRE interface • TX - yellow LED data transmission through 1-WIRE interface 	
Nominal Operating Conditions		
Power requirements	10 - 24 – 30 V DC	
Power Cable	Recommended length of power cable – up to 3m	
Power	3W	
Protection from reverse power polarization	YES	
Galvanic Isolation	1kV DC or 3kV DC - between power circuit and RS422 signal line	
Optoisolation	3kV - between signal line 1-WIRE and RS-422	

Operating temperature	0 ÷ +23 ÷ +50°C
Humidity	5 ÷ 95% - non-condensing
Position during operation	Free
Mounting	Rail mounting according to DIN35 standard / TS35.
Electromagnetic compatibility	Resistance to disruptions according to the standard PN-EN 55024. Emission of disruptions according to the standard PN-EN 55022.
Safety requiring	According to the PN-EN60950 norm.
Environment	Commercial and light industrial.
Enclosure	
Dimensions	53mm x 90mm x 58 mm,
Material	Noryl UL. 94 V-O
Degree of casing protection	IP40
Degree of terminal protection	IP20
Weight	0,10 kg
According to standard	DIN EN50022, DIN EN43880
Storage and transportation conditions	
Storage temperature	-40 ÷ +70 °C
Humidity	5 ÷ 95% - non-condensing

Dear Customer,

Thank you for purchasing **CEL-MAR Company** products.

We hope that this user manual helped connect and start up the **ADA-401W converter**. We also wish to inform you that we are a manufacturer of the widest selections of data communications products in the world such as: data transmission converters with interface RS232, RS485, RS422, USB, Current Loop, Fibre-Optic Converters and Ethernet or Wi-Fi.

Please contact us to tell how you like our products and how we can satisfy you present and future expectation.

CEL-MAR sp.j.

Zakład Informatyki i Elektroniki
str. Ściegiennego 219C
25-116 Kielce, POLAND

Tel.....: +48 41 362-12-46
Tel/fax.....: +48 41 361-07-70
Web.....: <http://www.cel-mar.pl/en>
Office.....: office@cel-mar.pl
Sales department.....: handlowy@cel-mar.pl
Technical information: support@cel-mar.pl