

User Manual for

GPS/3G/4G, 4/8ch,D1,Hard Disk Mobile Digital Video Recorder(MDVR)

Model: JH4&JH8



Catalogue

1. Product Specification	4
1.1 Product Overview	4
1.2 Key Features	4
1.3 MDVR detail specifications to see Table 1	4
1.4 MDVR electric Specifications to see Table 2	6
1.5 Product Applications	6
2. Appearance of Product	7
2.1 Device Appearance	7
2.2 Device drawing Dimension & Install Holes	8
2.3 Front & Back Panel led & Plug-in module	9
2.4 Back Panel interface definition	10
2.5 Power Cable	12
2.6 GPS Antenna and 3G/4G Antenna	12
2.7 Alarm input and output	12
2.8 Device Installation Guide	13
3. Remote Control Function Instruction	17
3.1 Remote Control	17
3.2 Text Input	19
3.3 Video settings	19
3.4 PTZ connection way and setting	20
3.5 PC playback of the video file	21
3.6 Fast report by vehicle server	23
4. General settings	24
4.1 Date & Time	24
4.2 Vehicle settings	25
4.3 User management settings	26
4.4 Network Settings	26
5. Record Setting	27
5.1 Basic Settings	27
5.2 Main Code	28
5.3 Sub-stream	28
5.4 Recording schedule (24 hour)	29
5.5 Mirror Record(Optional)	29
5.6 SD Record	29
5.7 Alarm Record (Not support temporarily)	30
5.8 Speed Record(Optional)	30
6. Alarm settings	31
6.1 Sensor Settings	31

6.2 Speed Settings	31
6.3 G-Sensor Settings	32
6.4 Temperature alarm	32
6.5 Motion Detection	33
6.6 Linkage Settings.....	33
7. TOOLS.....	34
7.1 Parameter configuration.....	34
7.2 Format	34
7.3 Log Search.....	35
8. Peripheral Settings	35
8.1 PTZ Settings	35
8.2 3G/4G settings	36
8.3 WIFI Settings.....	36
8.4 Oil settings.....	37
9.Record Search.....	37
10. System Info.....	38
Appendix 1: CMSServer platform interface.....	39
Appendix 2: Common problems and treatment.....	39
Appendix 3:storage space corresponding table.....	42
Appendix 4:MDVR Before loading the tool to check.....	42
Appendix 5:MDVR Before loading the installation of auxiliary examination.....	43

***The final interpretation of the specification, pictures and text interpretation all belong to the company. Without notice when content is changed!**

1. Product Specification

1.1 Product Overview

Hard Disk Mobile DVR (Automotive) is a cost-effective, multi-functional device designed for video surveillance and remote monitoring of your mobile assets. It uses a high-speed processor, an embedded **Linux** platform, and the most advanced technology in the IT field, such as **H.264** Video Compression/Decompression, **3G/4G** network transmission technology and **GPS** positioning technologies. MDVR can realize four/eight channel video recording. Each channel supports CIF, HD1 and D1 image solution. Drivers' driving information, GPS data and alarm data are recorded in **Hard disk** which is used as the storage medium. The MDVR may look simple in its exterior design, provides powerful auto black box features, installation flexibility and high reliability.

1.2 Key Features

4/8 channel video & audio synchronous real-time recording and playback
 4ch D1@25fps; 6ch D1@25fps, 8ch HD1@25fps , 8ch CIF@25fps options.(PAL)
 Built-in 2.5 inch HDD/SSD, supports max 1TB, Professional hard disk damping technology.
 3G/4G network , such as HSUPA/HSDPA/WCDMA/EVDO is selectable.
 Built-in GPS module.
 Built-in G-sensor
 External WIFI special interface.
 Built-in 1 SD card for backup recording when HDD/SSD errors.
 2 high speed USB2.0 interfaces, the front is used to export record file. The back is use to mirror recording for waterproof and fireproof.
 8 digital alarm inputs, 2 digital level output.
 3 RS485 interfaces, 1 RS232 interface.
 Built-in hard disk heating technology. It can be worked in $-40^{\circ}\text{C} \sim +75^{\circ}\text{C}$.
 Power supply: 8V~36V

1.3 MDVR detail specifications to see Table 1

Table 1 : MDVR Specifications

Items	Parameters	Specifications
System	Language	English
	Operation Menu	Graphical User interface (OSD menu)
	Password	Users Password/ Administrator Password
	Video input	4-CH/8-CH video input 1.0Vp-p,75Ω
	Video output	2-CH composite video output 1.0Vp-p,75Ω
	Video Display	1/2/3/4/8 channels synchronous

Video	Video Signal	PAL,NTSC
	Video Compression	H.264 Main profile PAL:100fps at D1, NTSC: 120fps at D1
Audio	Audio input	4CH/8CH Audio input.(Software supports simultaneous open 2 Audio)
	Audio output	2 CH Audio output
	Recording mode	Audio & Video sync Recording
Image Processing & Storage	Image Resolution	4CH:4D1 , 4HD1, 4CIF options; 8CH:6D1 , 8HD1, 8CIF options
	Video Compression	H.264 Main profile
	Video bit rate	CIF: 1536Kbps ~ 128Kbps HD1: 2048Kbps ~ 512Kbps D1: 4Mbps ~ 1Mbps, 8 levels optional. Highest: 1 level Lowest: 8 level
	Audio Compression	ADPCM, G.726, G.711 options
	Audio Bit rate	8KB/s
	Storage	Support One HDD/SSD Max 1TB Support One SD Card Backup when HDD/SSD is error. Support Mirror Recording with a expand Fireproof Box of SD (Optional)
Alarm	Alarm input	8 digital level inputs,below 4V is low level alarm,above 4V are high level alarm
	Alarm output	2 digital level outputs,output voltage level:12V
24PIN Communication Interface	RS485 Interface	Support 1-RS485 interface
	RS232 Interface	Support 1-RS232 interface, Can be connected to digital voice intercom
	WIFI Interface	Support 802.11b/g/n,2.4G internal or 5.8G external WIFI
6PIN Extended interface	Support 2 RS485 interface, Support connecting LCD control panel via extended interface.(Optional)	
3G/4G	HSUPA/HSDPA/WCDMA/EVDO Optional or FDD-LTE/TDD-LTE Optional	
GPS	Built-in GPS module, Geographical coordinates, speed can be recorded in hard disk and also can be transmitted to CMS.	
Acceleration Sensor	Embedded acceleration sensor	
Software	Playback	Playback Software is used to playback video file, GPS track, G-sensor, and alarm information.

	CMS	Center vehicle management software platform, it can manage more than 20000 devices at same time, if need to manager more units, add more servers to realize it.
Software Upgrade	Support Flash disk to upgrade the firmware.	

1.4 MDVR electric Specifications to see Table 2

Table 2: MDVR Electric Specifications

Items	Parameters	Specifications
Power input	8V~36V	8V~36V, When long-term under 8V, or long-term over 36V, Auto power off, enter protected mode.
Power output	12V	12V (+/-0.2V) ,Max:3A.
ACC Detection	≤4V	Power OFF.
	≥5V	Power ON.
Video input Impedance	75Ω	75Ω for each video input impedance
Video output Volt	2Vp-p	Output 2Vp-p CVBS analog signal, displayer device input need 75Ω impedance to fit it.
I/O interface	0~4V	Low level alarm
	>4V	High level alarm
Operating Temp	-40℃~75℃	Under well-ventilated environment.

1.5 Product Applications

The MDVR products application connection diagram:

Please refer to figure 1-1, This product can be used for video surveillance or remote monitoring which applies in common or special vehicles such as buses, logistic vehicles, trucks, long-distance coaches, taxis, tankers, cars, school buses, police cars, patrol cars. In front-end it mainly collects video signal by dedicated automotive camera, then transmits to the MDVR host via a special video cable to do the video compression and image processing, which is locally storage in SD card. It can also be remote monitored or remote video recorded and downloaded by the remote client if with 3G/4G models. It can real-time locate the vehicle position. Figure 1-1 schematic diagram is a common mode of application, each function during actual use will vary with the presence of module.

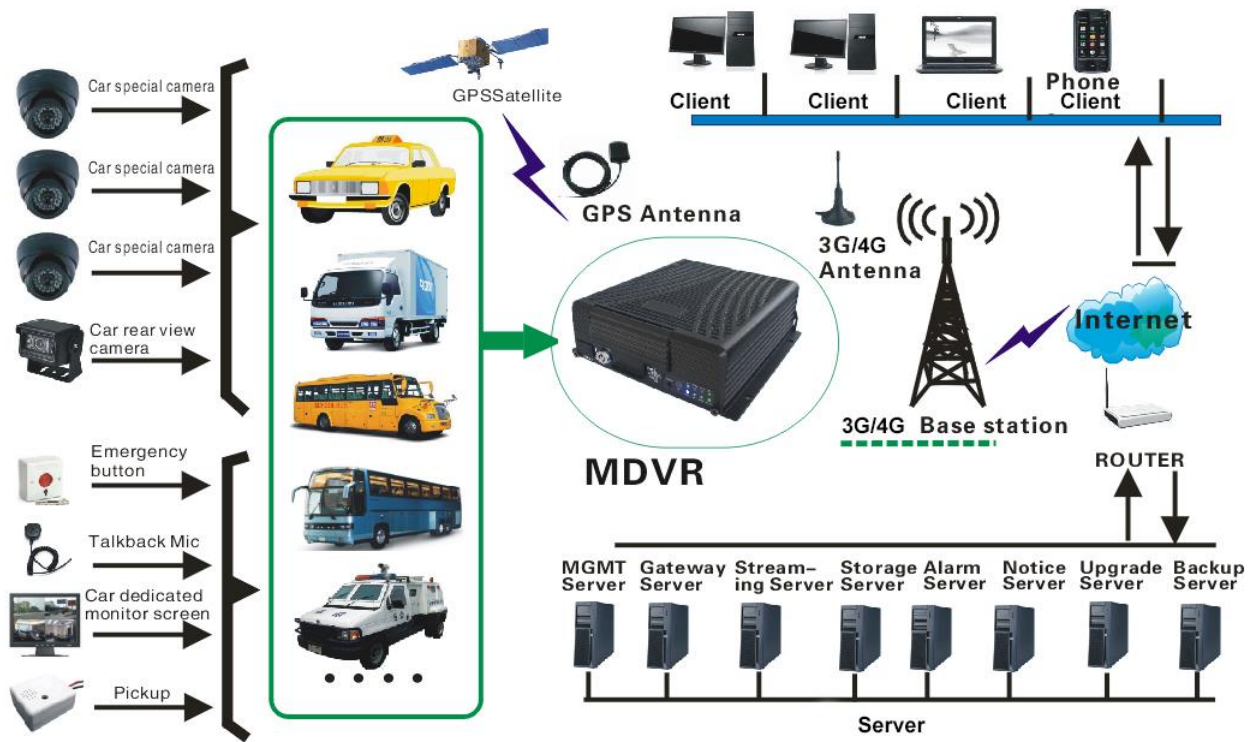

Figure 1-1
MDVR Schematic diagram

2. Appearance of Product

2.1 Device Appearance



2.2 Device drawing Dimension & Install Holes

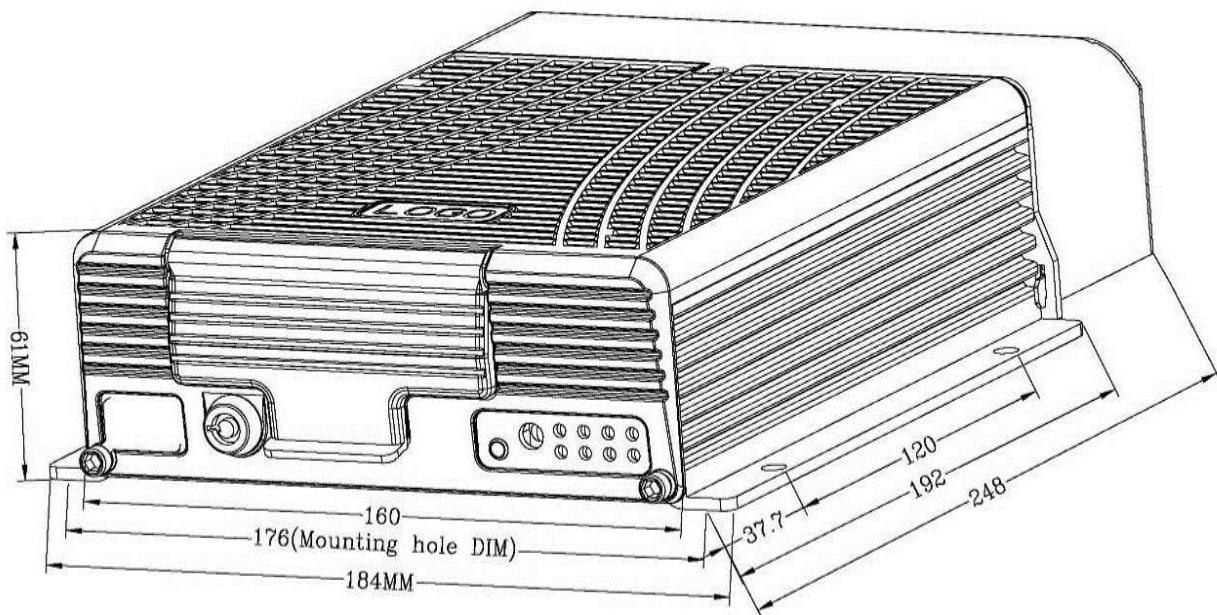
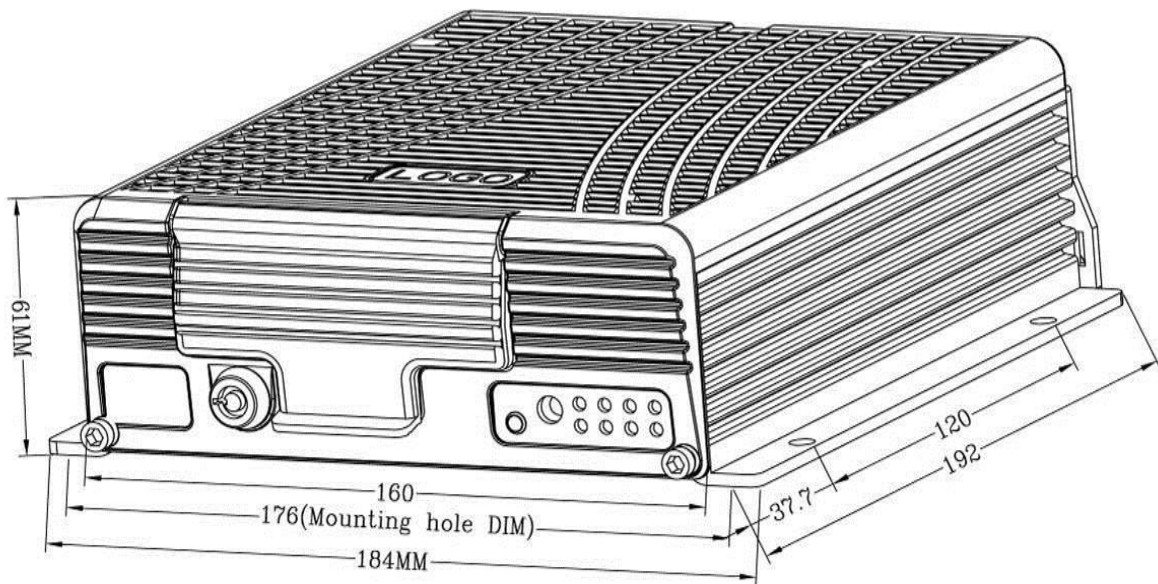

2.3 Front & Back Panel led & Plug-in module.

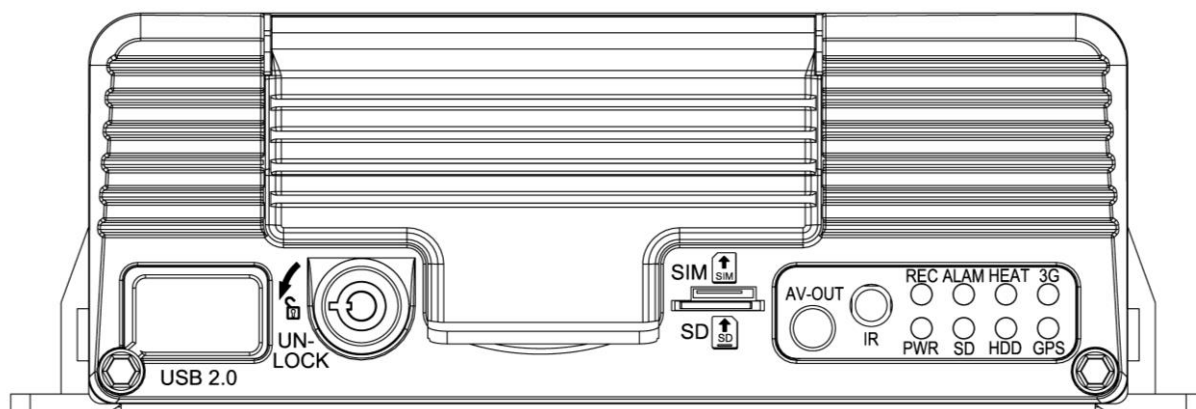

4ch and 8ch MDVR Front



4ch and 8ch MDVR Front

Table 3 : Front Panel definition

Interface	Items	Description
Video out	AV-OUT	Video Audio and 12V out analog output
LED	REC	Recording LED , light on when recording
	ALM	Alarm LED, light on when device work abnormally
	HEAT	Light on when heated
	3G/4G	Light on when 3G/4G module exist
	PWR	Power LED ,light on when power work normally
	SD	Light on if SD card exist
	HDD	light on if HDD exist, flash when recording
IR receiver	GPS	GPS signal LED , light on when GPS module exist ,flash if signal exist GPS
	IR	Receive remote control signal

Electronic key	LOCK	When device is working unlock the E-key, system will power off ,lock the E-key .system will work normally
USB Port	USB 2.0	Upgrade and Export video data

2.4 Back Panel interface definition

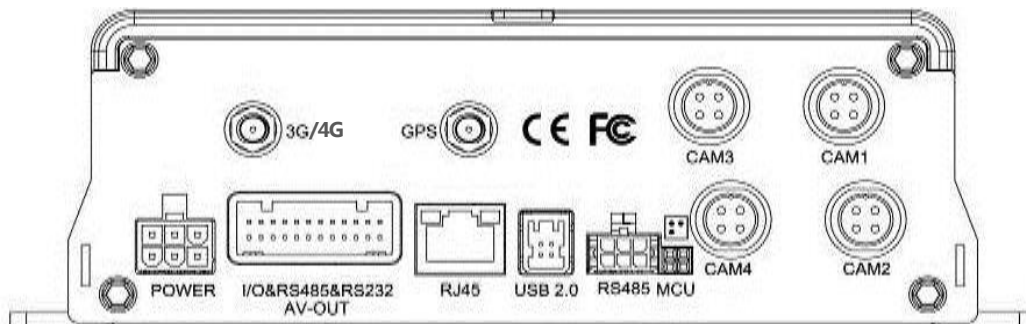

4CH MDVR Back

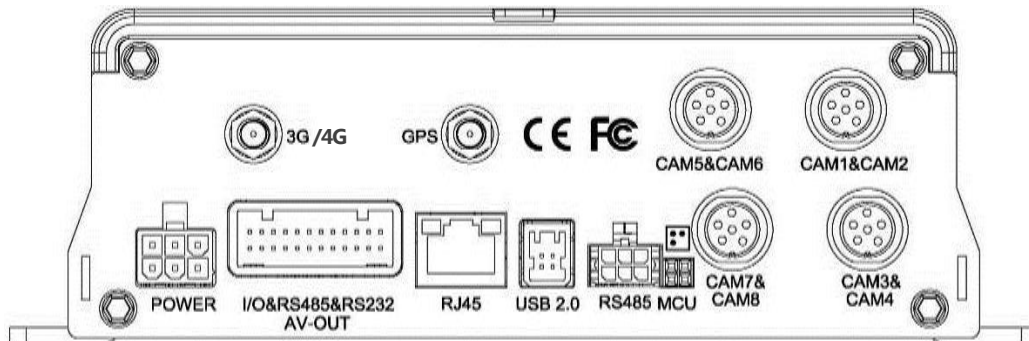

8CH MDVR Back

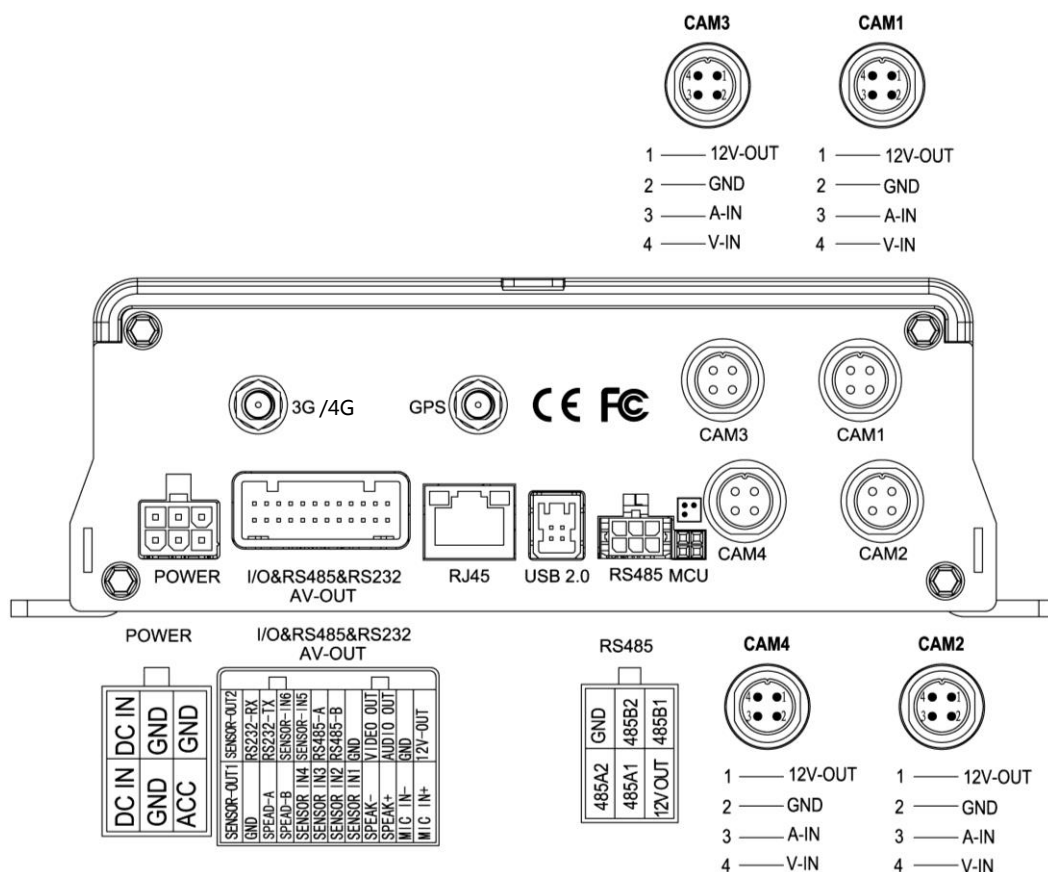

4CH MDVR Back signal definition diagram

Table 4: Back panel interface Definition Table

Interface	Items	Description
3G/4G Antenna Interface	3G/4G	3G/4G Antenna Interface
GPS Antenna Interface	GPS	GPS Antenna Interface
Power Input Interface	POWER	Power input interface
I/O Serial interface	AV-out I/O&RS485&RS232 AV-OUT	Switch input interface, high level(>4V Input) Vehicle speed pulse signal. RS232 Digital voice intercom
Network Interface	RJ45	Insert network cable ,the LED will light on when network is connected successfully
USB Interface(Optional)	USB	Mirror image recording storage media
6PIN Extended interface	RS485	RS485 Serial Interface
Printer Interface	MCU/ICP	System debugging information interface
AV-IN	CAM1.2.3.4	Video, Audio input and 12V out

2.5 Power Cable

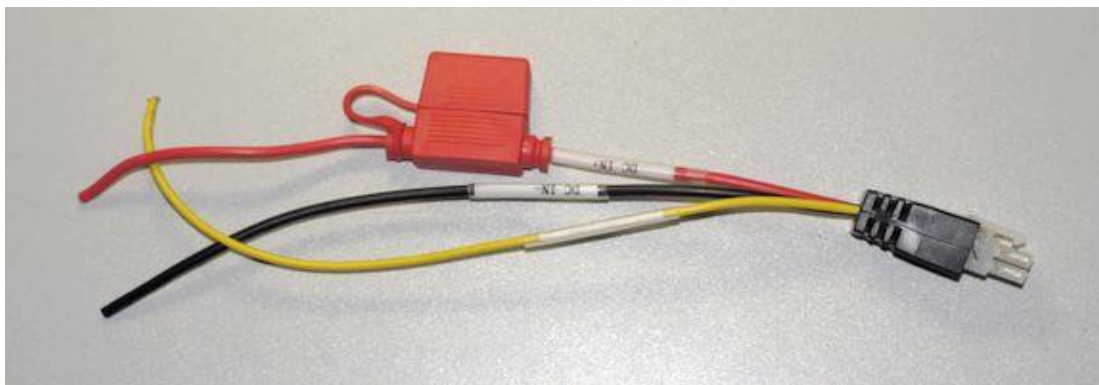

Power cable as picture 9, one end is 6pin white plug , it connect with the 6pin white plug of device back panel. The red and black cables are directly connect to the vehicle's battery. Red cable connect to positive , black cable connect to negative . Yellow cable is FIREWIRE. The device will automatically start when turn on the vehicle key ,and close when turn off the vehicle key . Yellow cable is connected to the gear that vehicle key open all the dashboard light(the gear of starting vehicle motor).

Notes:

- 1) Before connecting, confirm the voltage is between 8V—36V or else ,if over this range ,the device will be fired
- 2) After connecting the cables, Ensure that power cables are insulated to prevent short circuiting and burning out the battery.
- 3) The Yellow cable must be connected to the vehicle ignition cable, otherwise the device will not be able to execute the delayed shutdown and the final moment of the video will be lost.
- 4) Note: Connection to the vehicle's engine must be connected directly to the positive anode of the battery. Do Not Use bond strap for grounding as it will produce negative pulses that would interfere the device's normal operation. The negative pole of the power code must be $\Phi 1.5\text{mm}$ and above.

2.6 GPS Antenna and 3G/4G Antenna

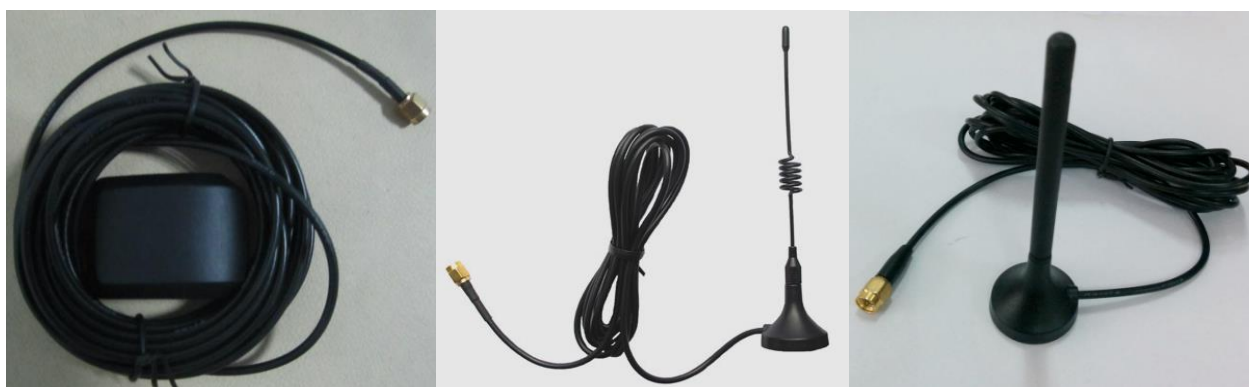

GPS

3G

4G

2.7 Alarm input and output

The device has 8 alarm input and 2 alarm output interfaces. Alarm input detection is level detection.

Various state of alarm level can be detected while the vehicle is in motion, such as braking, steering horn etc. Below is a diagram that shows when the braking vane is depressed, the MDVR would be able to detect the high level, otherwise, just detect the low level.

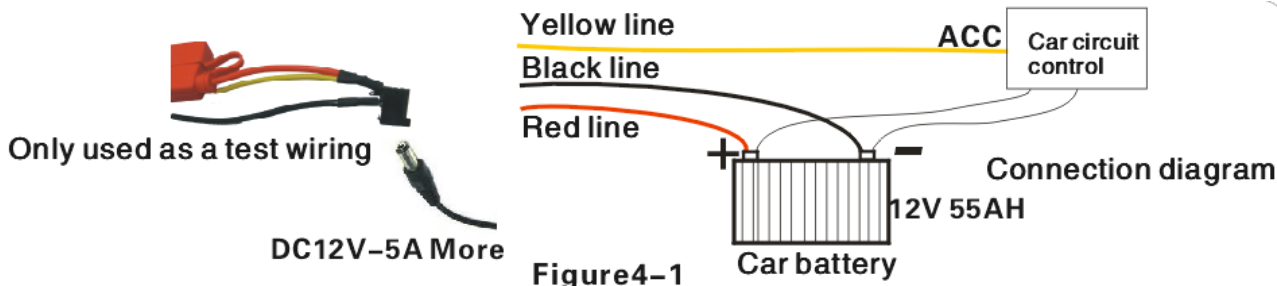

Alarm outputs are level output drive capability for the 200MA, if you want to drive relatively large power device, must connect external relay. Shown below is the Alarm output photoelectric alarm wiring diagram.

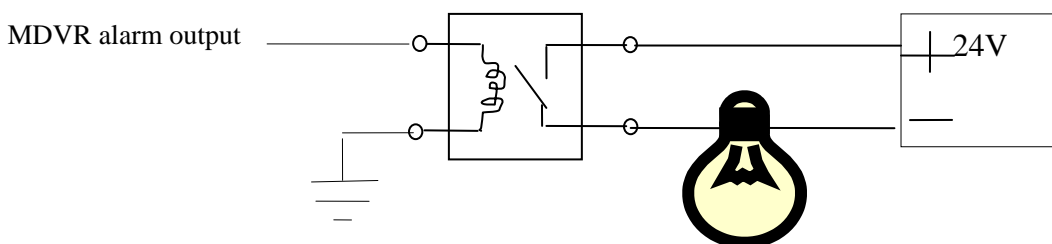

2.8 Device Installation Guide

A Inspecting the Accessories

After unpacking, please check the device for damage or deformation. If there are, please do not install the device and get in touch with the supplier. In the product box there is a packing list. Please cross check this list with the device and its accompanying accessories.

Table 5: Packing List

Hard Disk Mobile DVR-JH4 Packing List			
Item	Specifications	Unit	QTY
Host Machine		pcs	1
Accessories Box		pcs	1
Power Line-6PIN	6PIN Big557 L=200mm	pcs	1
Alarm Line-24PIN	AMP24PIN , L=200mm	pcs	1
Remote Control		pcs	1
HDD/SSD Case		pcs	1
Connecting Line	4PIN Air connector, convert RCA,BNC,DC L=200mm	pcs	4 (According to demand)
Electronic Key		pcs	2
Desiccant		pcs	1
Pearl Cotton		pcs	2
GPS Antenna	G503 L=5m	pcs	1

3G/4G Antenna	3G/4G Antenna	pcs	1
Protective cover		pcs	1
Screw M3	KM3*5mm	pcs	4
US-made screws # 8	AC #8*9MM	pcs	1
Allen wrench	3#	pcs	1



4Pin Port Convert BNC Composite video Cable



8CH wiring, A is the first CAM,B is the second

B HDD/SSD,SIM card, SD card installation

Unlock by the key, insert the HDD/SSD into the HDD/SSD slot in front of the mainframe. Notice: if draw out The HDD/SSD, the front part of HDD/SSD should has a space of over 10cm(the length of HDD/SSD)

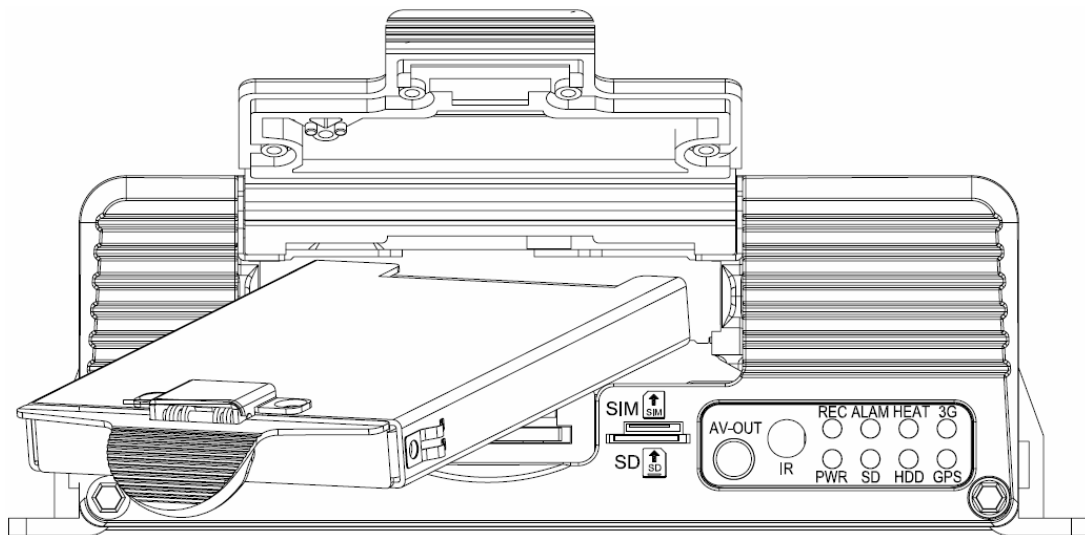

PLUG THE HDD/SSD-BOX

Pull and plug the hard disk box, will need to do the following

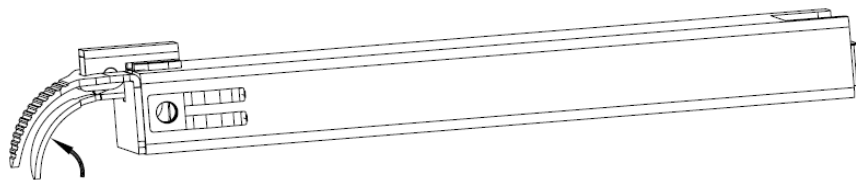

Push the shrapnel

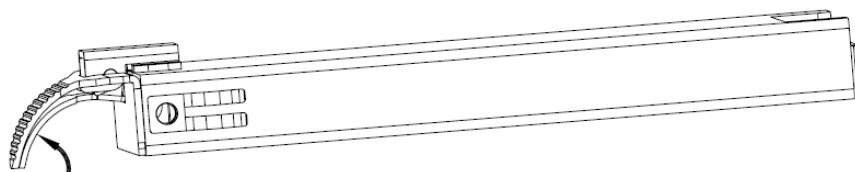

The need to get this effect

Plug the HDD/SSD box, shrapnel and the handle pressed

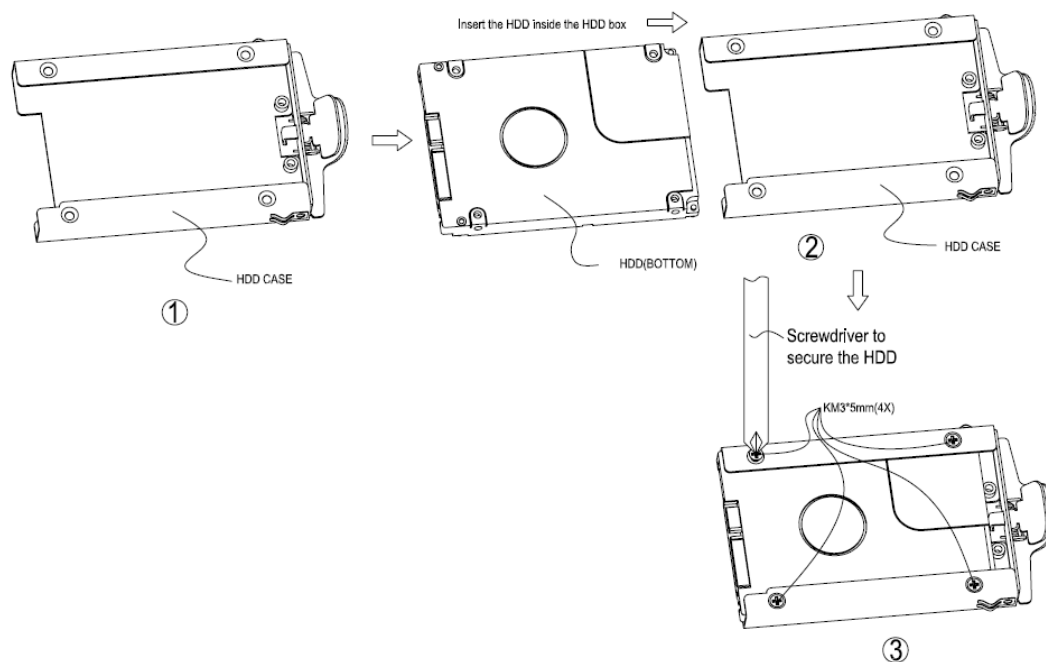

Note when the HDD/SSD is installed

SIM card is located on the communication board, move the small baffle at the bottom of the mainframe, you can see the interface of SIM card .

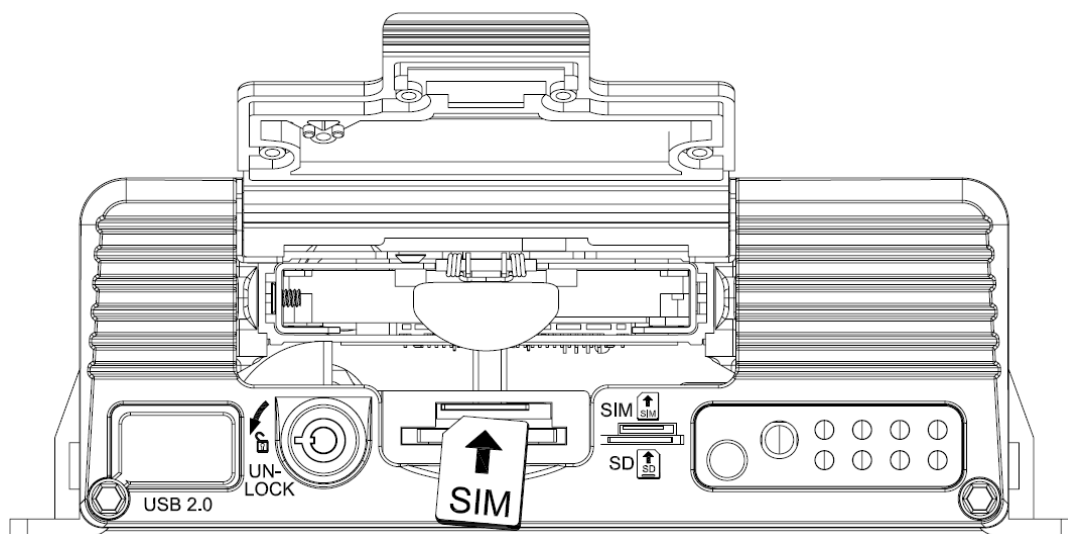

If system support wireless network communication, need install SIM card. SIM card and SIM are in the same location, you can see them, just when you move the baffle at the bottom of the mainframe .

3. Remote Control Function Instruction

3.1 Remote Control

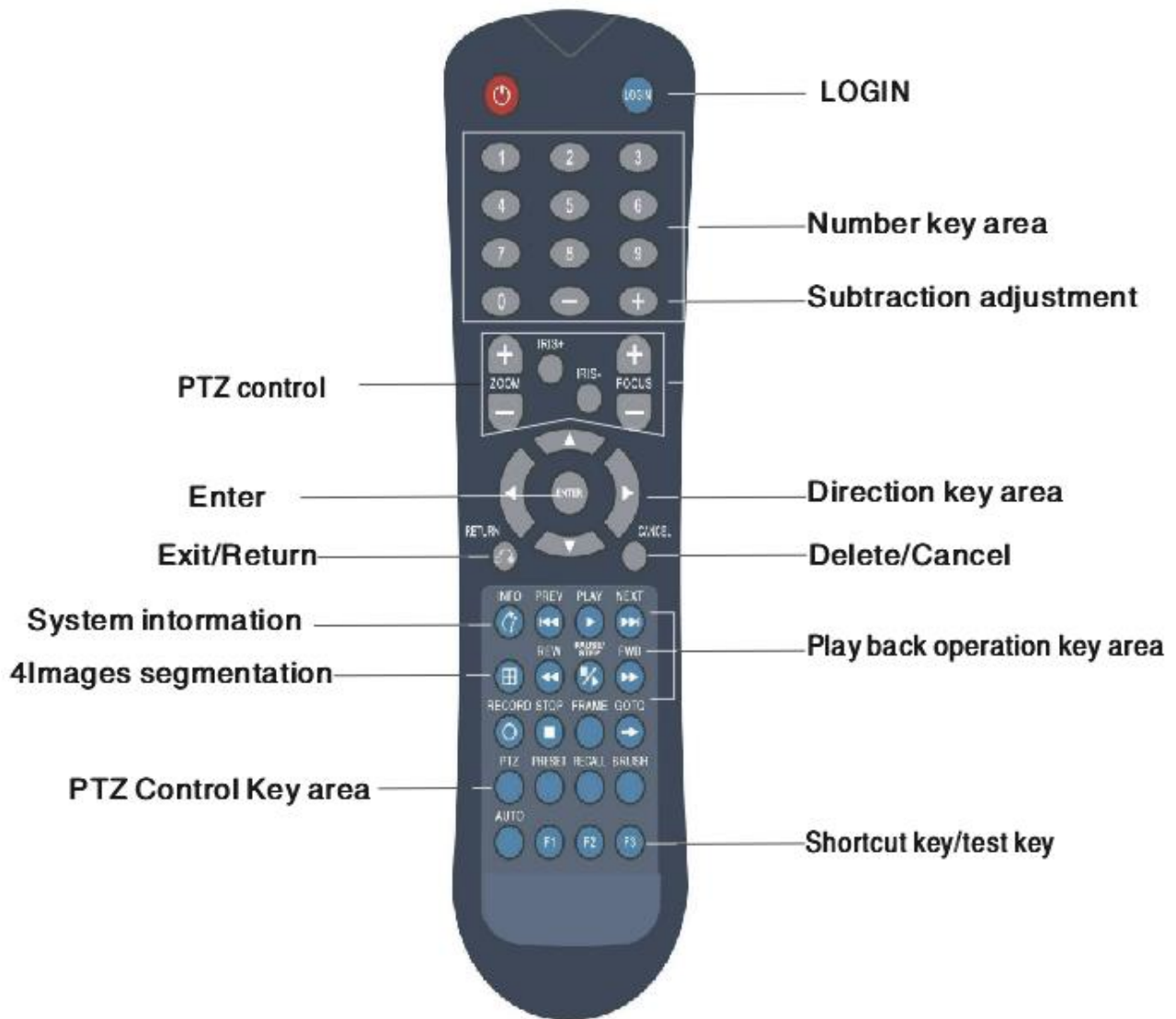

There is no control button on MDVR panel, need remote control to fit operating

Key-press & function as below:

Digit keys zone:





【0—9】 key: Under setting, use for select digit. During playback and preview, 1,2,3,4 is for the switch of the channels

【+】, **【-】** key: adjust digit when plus or deduct or delete

【ENTER】 key: under setting, means select and save

On playback condition, press ENTER can reveal parameters in OSD OVERLAY menu when it's ON on screen.

Table 6 : Function keys on remote control

Startup/power off	Through screen, press this button twice for reboot (soft start key) (note: can't be use now)
LOGIN	When setting password, press LOGIN input password. Do please remember password due to device have no reset function.
INFO	Check info
 Digit keys1,2,3,4,5,6,7,8	Press it, Switch between 1-channel/2-channel/3-channel/4-channel/ 8-channel version. Press digit key 1,2,3,4,5,6,7,8, can separately switch to CH1,CH2,CH3,CH4,CH5,CH6,CH7,CH8
RETURN	Return to upgrade, exit setup menu and return to screen.
PAUSE / STEP	When playback recording, press STEP, a time play a step, press PAUSE, it stop. Press play key, then normally play.
GOTO	When play back, press it can jump to designated time and play.
FRAME	Press FRAME key, then FRAME play.
 (PLAY)	PLAY key, (when PAUSE, it will show still image)
FWD	FWD for playback recording, 4 grades: 2X,4X,8X,16X
REW	REW for playback recording, 4 grades: 2X,4X,8X,16X
	Stop manual PTZ or recording key
	Start manual recording key
NEXT	Turn to next page/ next file when playing.
PREV	Turn to previous page/ previous file when playing
PRESET,ZOOM+/-,FOCU S+/-,IRIS+/-,PTZ,PRESE T,RECALL,BRUSH	PTZ function keys
AUTO,F1,F2,F3	F1 is shortcut key, F2, F3 are Spare keys. (Reserved for future)

3.2 Text Input

Need to use input method when input text, such as the company name, license plate number, driver's name, line number, and other text input needs when requires input method under other menu. Take inputting "Yue B95886" for example after entered the input interface to illustrate the input steps

Step One: in the state of Chinese input, as shown in Figure 4-2, Character YUE(GuangDong)' s Pinyin is YUE, move the cursor to press ENTER key to input the first Chinese letter y, it will display the corresponding PinYin combination 1-5, if there is no PinYin as YUE, please press the FWD key on the remote control to the next pages; when it shows 1.you 2.yu 3.yuan 4.yue 5.yun on the next page, please press the number 4 on the remote control which will show 1-5pcs of Chinese characters, if there is no YUE character, please use FWD button to turn the pages; when it shows 1 read 2 key 3 Yue 4 Guangdong Yue, please press 4 to input the first Chinese character YUE(GuangDong).

Step Two: Now you will need to input the letter B, move the cursor to press ENTER key to switch the input method to the state of capital letters, as Figure 4-3, then move the cursor onto the letter B to press ENTER key to input it. Step Three: Next you will need to enter numbers, press it again to switch to Chinese input state, you can not input numbers under Chinese input state, then you need to move the cursor to the "in (middle)" word, press ENTER key to turn to EN, and then enter numbers 95886.

After the completion of above steps, press the RETURN key to go back and save, other text input under other menus will be more or less the same. Please press CANCEL to delete it when there is a typo during the input process.

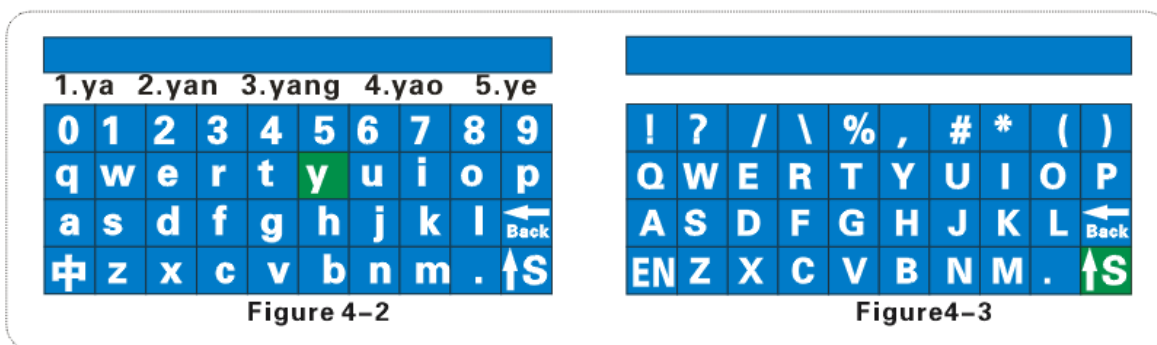

3.3 Video settings

1: Video Start Up

After the installation of a new SD card in the device, the formatting is recommended after normal boot into the system, in order for system to have better compatible relationship with its format. After the formatting, host will automatically start up the video when restart.

2: Timer recording

Firstly modify to be timing video under the System menu – Video Settings – General Settings – Video mode, save and return to the previous menu level to be video plan, and then set the time period of the video; save it after setting finished.

3: Alarm recording

Firstly modify to be alarm recording under the System menu – Video Settings – General Settings – Video mode, then set the alarm pre-record time (range 0 –60s) and alarm video delay (30–900s); alarm output delay (5S–255S), which can be set according to the actual external alarm device.

Secondly it is needed to install the corresponding external alarm input device, such as the emergency button set by sensor, power switch for open/close door, brakes lights and other sensors; the following are the several main alarm settings of this device:

A: The sensor input alarm system, system menu – alarm settings – sensor settings

Set the menu (in Figure 4-21) with high or low trigger level, and then turn on the alarm; this menu is corresponding with four external alarm input SENSOR IN (which can be for eight external alarm output), it must be connected to the corresponding external sensing switch device, such as door-magnet power supply, emergency button, turning signal switch, brake lights (Figure 2-12), etc; rough connections are shown in Figure 3-4.

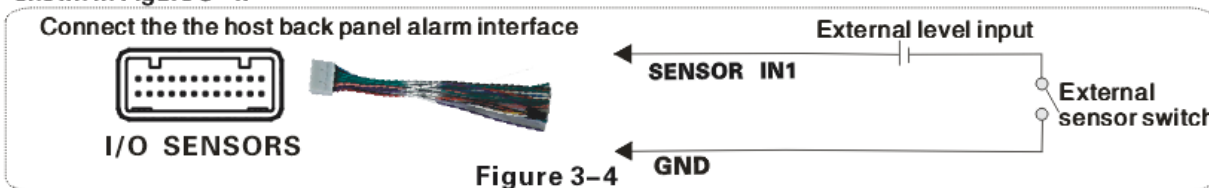

B: speed alarm setting system menu – alarm settings – speed setting

If the vehicle selects the GPS to get speed information which requires normal status of the GPS signal, then we need to set a high threshold speed limits, such as 100km / h that is the maximum speed limit, alarm is opened when vehicle is started; vehicle will output alarm when the vehicle speed exceeds 100KM / H

If you choose to obtain speed information from the vehicle, it must be connected to the speed pulse sensor, which is used to calculate the speed ratio (coefficient = pulse/speed), the pulse sensor is connected to the two wires SPEED-A and SPEED-B of our device, the speed ratio will be measured according to the set speed and pulse during vehicle's moving, which is a little complicated to operate; simple wiring in Figure 3-5.

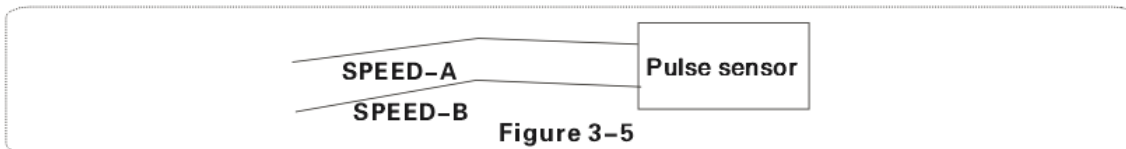

Figure 3-5

C: The acceleration alarm recording system menu – alarm settings – acceleration

Impact acceleration can be understood to be for a three-dimensional XYZ coordinate axis which can denote three groups of status—up and down, left and right, front and rear; the bouncing up and down, accelerate, Emergent brake, rollover, sharp turns, etc. during the moving process of the vehicle can all be expressed in XYZ. Threshold needs to be set by an associated value, it is firstly needed a calibration after the installation onto the vehicle, the calibration means to clear parameters X / Y / Z, secondly measure the allowed range of emergent brake & acceleration & bouncing up and down as well as the change value of a sharp turn of the vehicle during the operation, thereby to determine which axis's value changes a lot. These run status will be in real-time display and change. After setting the threshold, when the vehicle runs exceed above threshold, the alarm will be uploaded if the "alarm" opens.

D: Motion detection alarm recording System Menu – Alarm Settings – Motion Detection

Turn on the motion detection enabled switch, set the sensitivity level of high, medium and low based on the need, general settings is medium, and the next step is mostly to set the sensing area of the motion detection, motion detection area will use diagonal set, please refer to Figure 4-30. As long as you set the motion detection area and set the video mode as alarm recording, the image move will trigger the video to generate alarm recording files (Note: it can only take effect after setting and saving)

3.4 PTZ connection way and setting

Setup steps:

Firstly, select the PTZ protocol: divided into PELCO-D and PELCO-P protocol, most of people will choose PELCO-D

Secondly, set the baud rate: there are four options 1200/2400/4800/9600 which must be corresponded with the baud rate on PTZ

Thirdly, set the address code: directly input the address value corresponding with PTZ setting, corresponding is required. Generally the defaulted PTZ address code is 1, PTZ address code has adjustable DIP, it is needed to set different address codes to identify when there is many PTZs.

Fourthly, wiring: Connect control wire 485 on the PTZ to the RS485-A positive pole, connect the other one to the RS485-B negative pole.

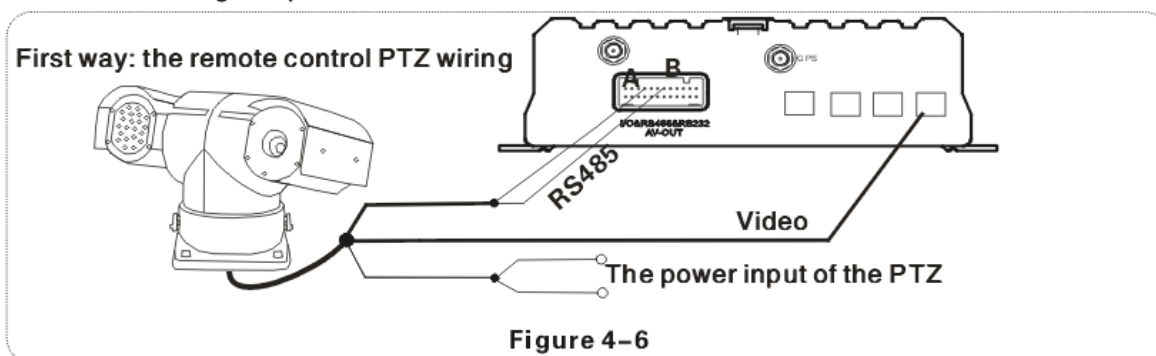
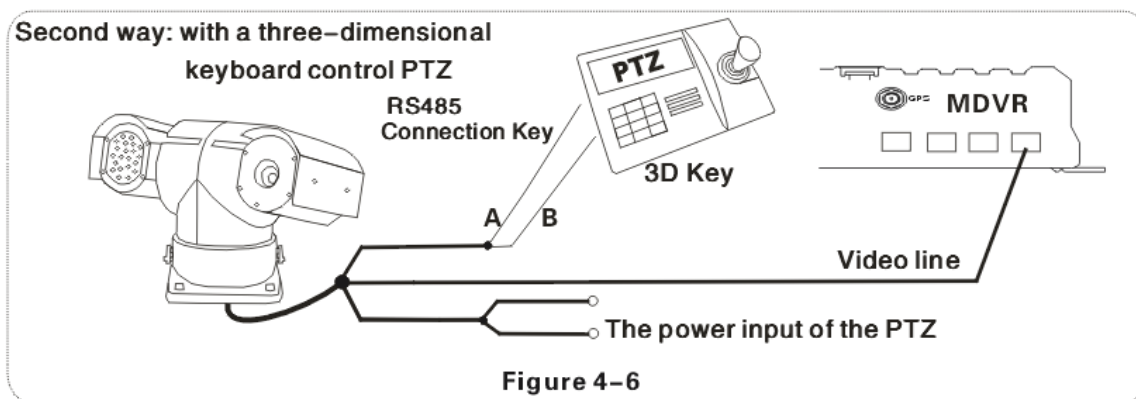

Figure 4-6



Note

After wiring and parameters setting of PTZ, users can only use remote to control PTZ after selecting the channel access to PTZ, for example, if PTZ connects through channel 2, then you need to switch to channel 2 maximize on the monitor interface to control it.



Fifthly, there are three ways of wiring, the first way is connecting the 485 control wire to the wire 485A and 485B on host, connecting the video cable to the host video input and then provide power to PTZ; this kind of wiring needs to set the MDVR host data be corresponding to PTZ data, and then use the remote controller or platform to remotely control PTZ.

The second way, the head of the 485 control wire directly connect to the three-dimensional control keyboard, do not need to connect the MDVR host, the video cable connects to the host video input, separately power supply to the PTZ and three-dimensional keyboard, and then set the keyboard parameters to be corresponding with PTZ. This wiring way is the most practical one, because it uses three-dimensional keyboard to control PTZ, which is faster, easier and more practical. It is recommended to use this way to install PTZ

The third way is to connect to both car host and three-dimensional control keyboard, so that both can be controlled and platform remote can also be controlled.

3.5 PC playback of the video file

You must install "Ext3 format driver of HDD"(Ext2Fsd-0.51) when you read HDD on your computer first.

Double-click installation files within MDVR Player **. Exe, and then select the installation language, support Chinese and English, and click "OK" and then click 'Next' to install the player after the completion of the shortcut icons displayed on the desktop. Installation steps are shown in Figure 3-7.

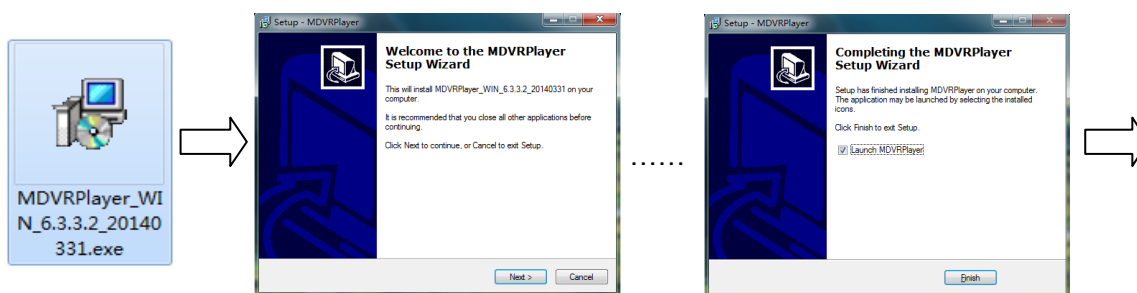



Account: admin password:000000

Connect Hard disk to the computer's USB port, the computer automatically recognizes the newly installed hard drives, video files are stored in the form of the date folder, open the folder and display video files, video files named suffix ". avi", Figure 3-8, play the file screen shown in Figure 3-9

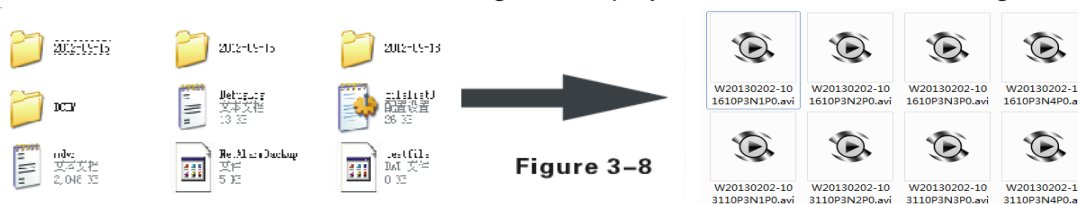

Figure 3-8

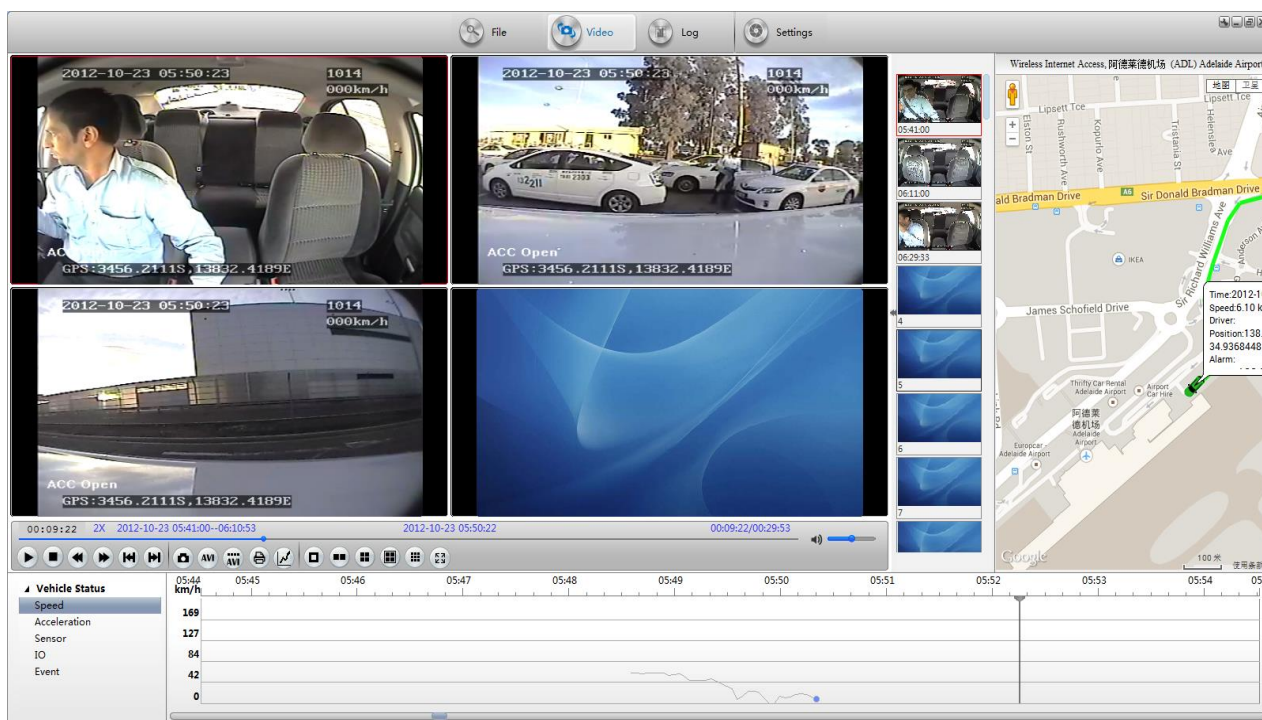

Figure 3-9

3.6 Fast report by vehicle server

Note: The following described is invalid to the host which is without 3G module, it is not needed to report to gServer platform

Step 1: Install the SIM card, 3G card which supports WCDMA / EVDO / TD-CDMA, detailed installation please refer to Chapter II, 2.2, and 2.7

Step 2: Enter into the system menu after starting up, firstly modify the host's device number, System Menu – General Settings – Vehicle Information – Device Number, device number range is from 00000 to 99999. Server identifies the host according to the device number, so it is very important to modify the device number.

If the modified device number cannot be reported sometimes, please check the server device number has been used or not.

Step 3: Modify the vehicle identification number; the vehicle information displayed on gServer platform is based on vehicle identification number. If it is not modified, it will display 00000 in default. If all are in default, it would cause inconvenience to find vehicles. So it is proposed to modify the vehicle identification number.

Step 4: Enter another menu settings, System Menu – General Settings – Network Settings, set the server IP and control port, the server

can be self-built, and can be affiliated to the manufacturer's server as well, enter the server IP and control port, which is typically 6608, the save by end.

The main process of gServer quick reporting is as Figure 3–10 below.

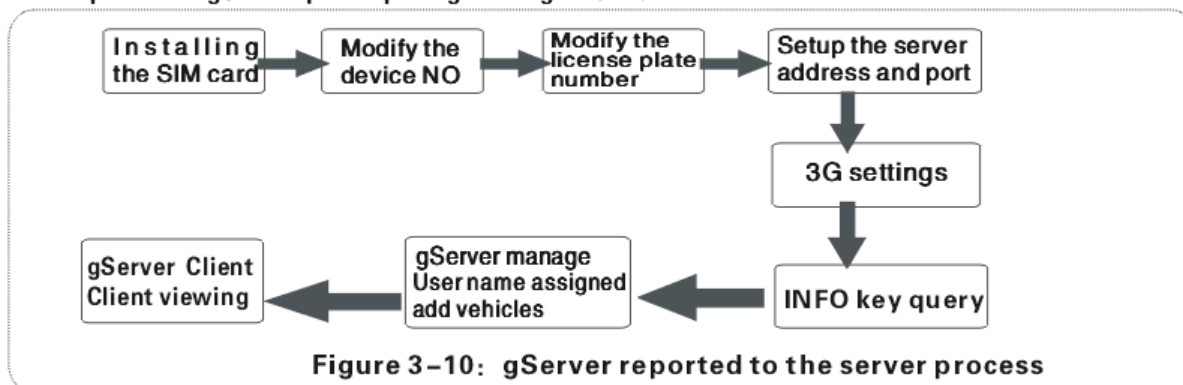
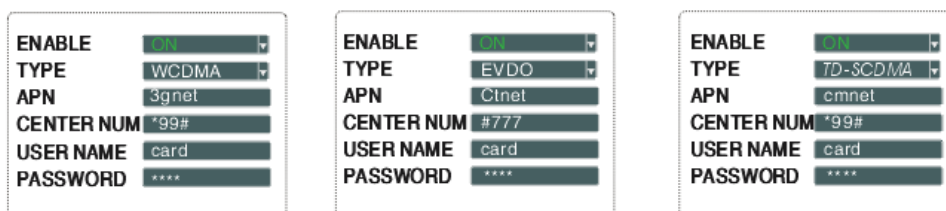

Figure 3–10: gServer reported to the server process

Step 5: Enter the system menu – peripheral – wireless broadband, which is with wireless settings inside.

A: wireless 3G settings

Please pay attention to the supporting type of network during wireless 3G setting: WCDMA, EVDO and TD-SCDMA. Also note the access point and the center number, The user name is in default in domestic which is basically not needed to modify, however there is also in some domestic places he 3G card needs to be entered by user name and password, and some foreign operators will need to enter user name and password as well, the access point and the center number will need to be modified too, which is required to input relevant information according to the local network data. You can press INFO key to query whether dialing is successful or not after setting.



C: local IP settings

Local IP setting is the setting after the RJ45 port access the network cable, set the local IP and central server number to make it be linked from local area network to WAN through the network cable, which can also report to gServer server platform.

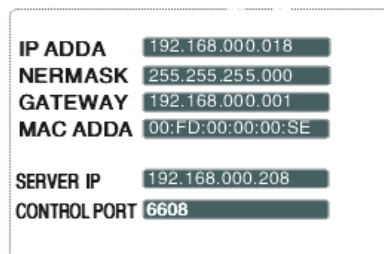

Step 6: These are networked into the way when connected to the network, the next step is in the CMS management software on the PC operation, the two steps: If you are self-built server, the client account and add their own vehicles and assigned vehicles; If it is mount server manufacturers, assisted by technical staff added. Ultimately reported to the CMS, CMS detailed operation, please refer to the relevant technical documentation.

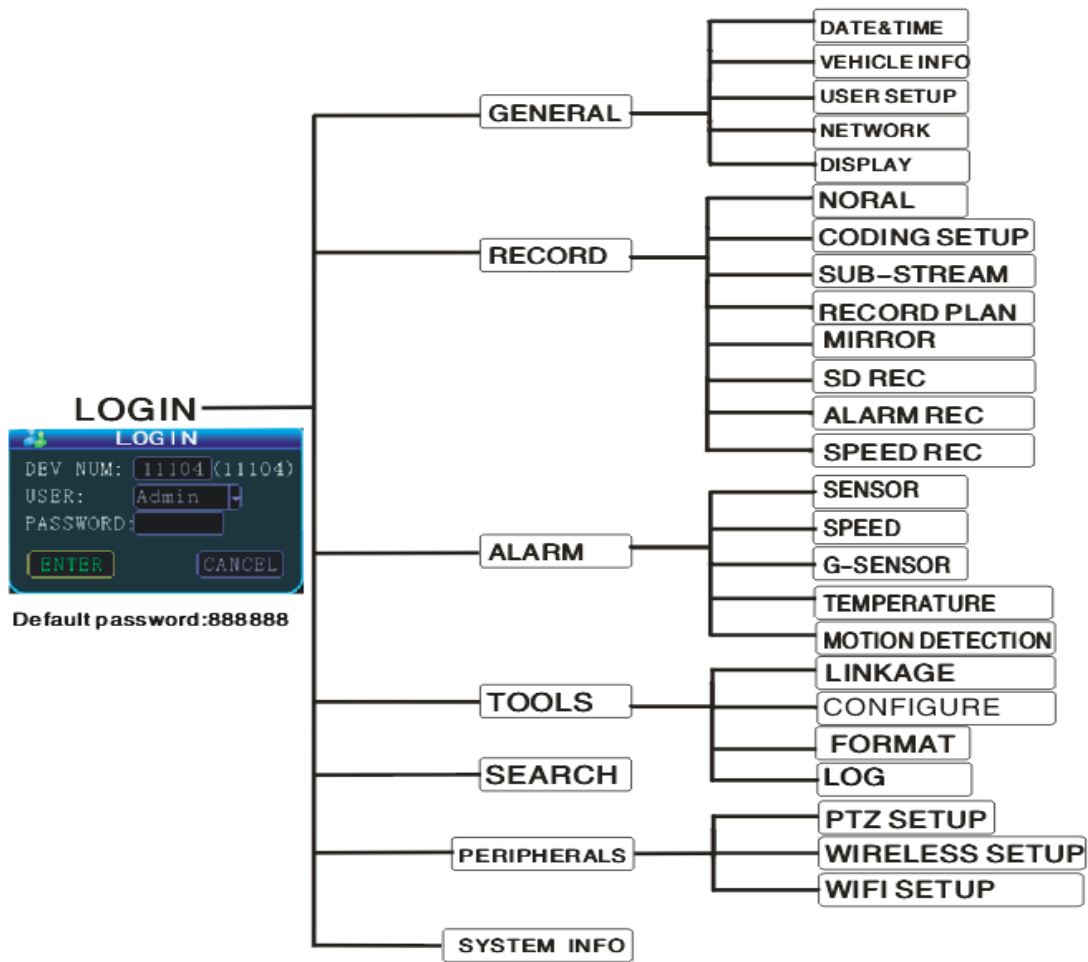

4. General settings



General settings is the first menu in system menu, the generic setting interface contains four function options: date and time, vehicle information, user management and network.

4.1 Date & Time

Set the system time and some other basic properties of the device

1. Date Format: Press "ENTER" drop-down menu to use the arrow keys to select the output format of

Hard Disk Mobile DVR User Manual V2.0
date (year-month-day, day-month-year, and month-day-year).

DATE TIME

Data Type DATE TUE

Time Format Time

Time Zone +

DST Switch

OPR Timeout

Timing Mode

Timing Time

Power Mode

Power Off Delay (5-1440mins)

MAINTENANCE TIME:

2. The date and time settings: two ways for time proofreading ---GPS time proofreading and manual time proofreading, when select GPS time proofreading, the modified time will change because of reaching the GPS time proofreading point, so if you want to modify the time, it is suggested to choose manual time proofreading mode, which can be in normal after modifying time. Way of modifying the time and date: move the cursor to the number which needs modification and directly

press the corresponding number keys on the remote control, press the save button after set.

3. Operating timeout: three options--1 minute, 5 minutes, 15 minutes for choosing to set how many minutes later will automatically exit the menu after entering the menu. General settings menu interface

4. When the GPS time proofreading opens, in the default time zone, such as the default GM +08:00 time zone, system will automatically proofread time by GPS when it reaches time proofreading point.

5. Power mode: the ignition mode / timer mode, the ignition mode is that MDVR began to start up after vehicle starts its key, this operation is recommended as the preferred default starting-up. timer mode is the operating mode of startup and shutdown at the point of time set by the user.

6. Power Off delay: In the ignition mode, as long as the wiring is correct, you can set the delay off of host, delay off time range is from 5 minutes to 1440 minutes, MDVR will continue to do the video recording by the delay off set time before shutting down when the vehicle is turned off.

7. Auto Maintenance function: when the MDVR work more than 24hours. setup ON, give it a time, MDVR will automatically restart to work properly, this need about 50 seconds.

4.2 Vehicle settings

VEHICLE INFO

Serial-Num 00-00-00-00-00-03-ee

Dev-Num

Company Name

Vehicle-Num

Driver Name

SIM-Num

Mile Accrual

1:Device Num.: user sets a unique device number to each device, which will automatically display on the right of the number input box. The device number is 6 digits & characters, digits are effective. If it is 3G/4G device, it is strongly suggested to set a unique device number, because a server requires only one device number.

2:Vehicle identification number: this number is recommended to be set during installation, because the vehicle identification number will be superimposed onto the video during video encoding to be strong video evidence. If you

do not enter the vehicle identification number, then it will show 00000 in default. For detailed input method, please refer to Chapter 3.2 *Text Input*

3: Company name, the name of the driver, SIM number, can fill out as demand.

4. Mile Accrual: Setup ON, mileage statistics and upload CMS client.

4.3 User management settings

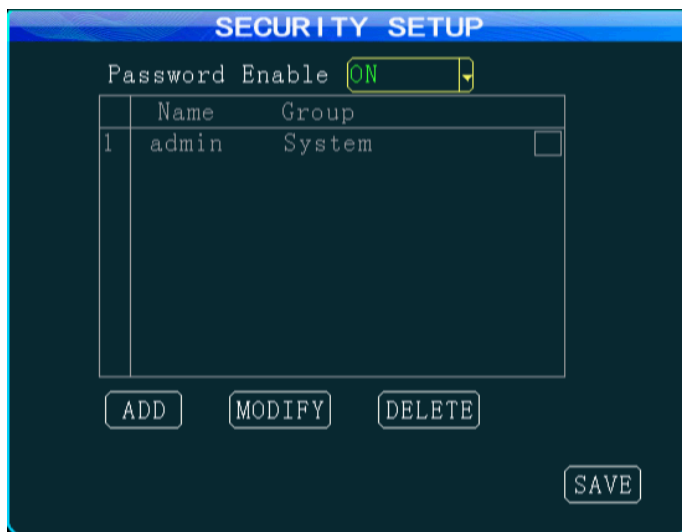

1.Password effective settings to select on or off.

2.Only administrators have permission to modify the passwords of users and administrators. Ordinary user’s password is initially set as 000000, and the initial password for administrator is 111111. When password change finishes and exit menu, it will need to use new password to log in again.

4.4 Network Settings

Network setup interface

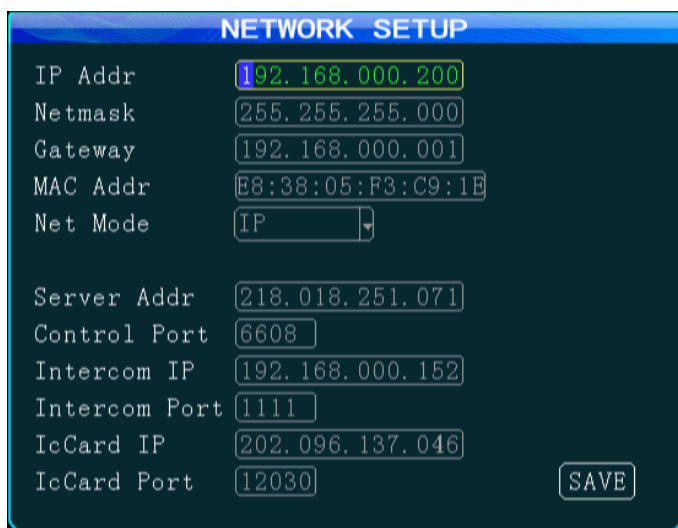

1.IP address Mask Gateway etc. are LAN network setting after plugging in the network cable, there is no need to input if you do not use them.

2.Net Mode:

IP: Server use Static external network IP;
DoMain: Server use Dynamic Domain Name Server.(You need to input your Domain Name and DNS IP when you select Domain mode)

3.Server’s IP address is the one MDVR host using 3G/4G to report to CMSServer platform central server, which generally is the public fixed IP, the IP address must be set up, or

else 3G/4G host cannot report to platform. this requires our host can support 3G/4G. this menu will no need of setting if the host is without 3G/4G module.

4.Control port: set to be the port number of the gateway server, generally the default is set to "6608"port

5, intercom IP, port: That need for an external intercom equipment, input intercom IP and port (the default is usually 12030).

6, IC card IP, port: That need for an external IC card device, enter the IC card IP and port

5. Record Setting

5.1 Basic Settings

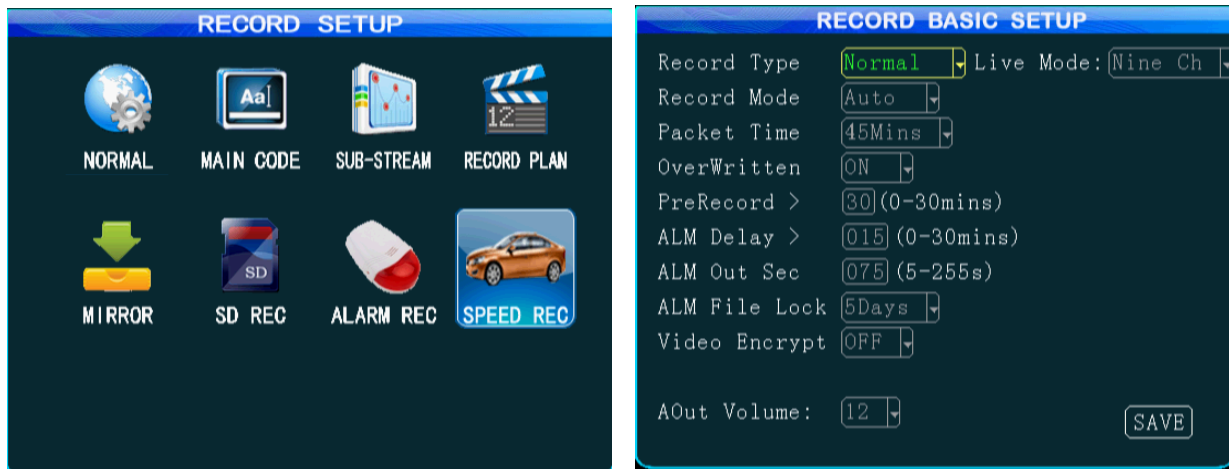

1. Selectable record type: common record or record I frame.
2. Selectable record mode: boot record / alarm record / timer record.
3. Selectable packet time: 15/30/45/60 minutes, which stands for the time period how long the video file will become a packaged file.
4. Automatically overwritten can be selected to on / off, when on, the previous video files will be automatically overwritten if the hard disk space is less than 2G as well as the mirror video disk & SD card space is less than 300M,.
5. Alarm pre-record time: when alarm occurs, the recording before the alarm occurs will be packed to be included into alarm record (range 0-30min).
6. Alarm recording delay: when alarm stops, the recording after the alarm stops will be packed to be included into alarm record (range 0-30min) to form an alarm recording file.
7. Alarm out sec: when alarm occurs, the continuous output time of an alarm after connected to an external alarm device, the output time (5S - 255S).
8. Alarm file lock time is the storage time for alarm video to be saved on the hard disk, the mirror disk, SD card. in protected storage time, the alarm recording will not be overwritten even if the SD card is full. there are optional 1/3/5/7/10/15/30/45 days under the drop-down menu, please set the appropriate number of days according to the hard disk capacity.
9. Video encrypt: Video files can be encrypted, using the player on a PC requires a password when playback.
10. Audio output volume: You can set the output volume.
11. Live mode: You can set the number of channels the boot screen.

5.2 Main Code

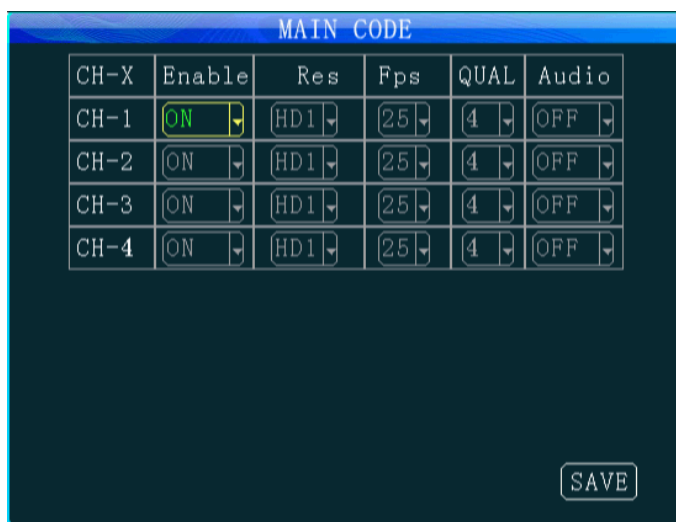

1. Enable: On means open the recording function of this channel, off means not recording. When some channels do not need record or video recording, you can switch off the channel in order to save the storage capacity of the storage device.
2. Resolution: optional D1/HD1/CIF.
3. Frame rate: PAL is with adjustable 1-25 frame, full frame rate is 25. NTSC is with adjustable 1-30 frame, full frame rate is 30.
4. Quality: optional level 1-8, level 1 is with the highest quality 1, while level 8 with

the lowest quality. the quality setting (good or bad) has a direct impact on the effect of record playback. Under the same resolution, the higher the quality, the clearer the record. The record file will obviously take up a relatively large space.

5. Audio: audio channel can be set on or off, if on, there is sound from the corresponding channel during record playback, maximum two-channel audio can be opened.

Note: The main code plus mirroring video can support 6 full frame D1 record.

5.3 Sub-stream

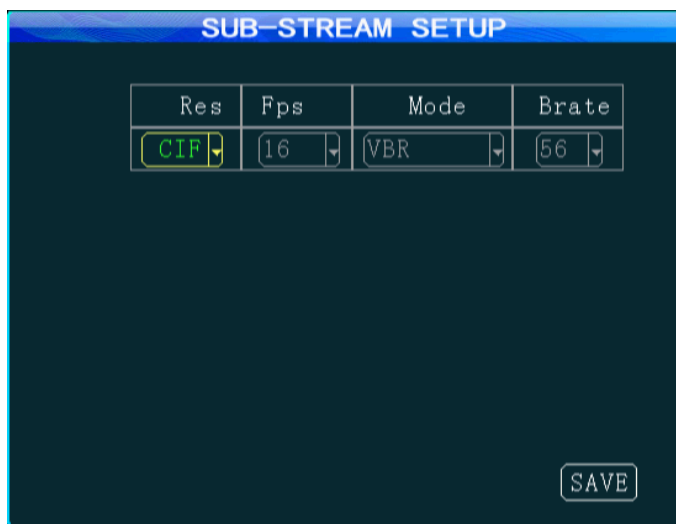

Description: sub-stream is important parameters when video and data are uploaded to the network through 3G/4G, and its settings are related to the clear and smooth watching effect of video on CMS platform, of course, network transmission mostly depends on the uplink and downlink rate of local network.

1. Video resolution can be set to be CIF or QCIF.
2. Selectable frame rate : 1-25(PAL),1-30(NTSC).
3. The bit rate can be set to dynamic bit rate (VBR) or constant bit rate (CBR), optional 16-384kbit / s.
4. Default setting is bit rate 96, frame rate 10. But this can be set according to your own network. If the network bandwidth is good enough, then the frame rate and bit rate can be set higher.

5.4 Recording schedule (24 hour)

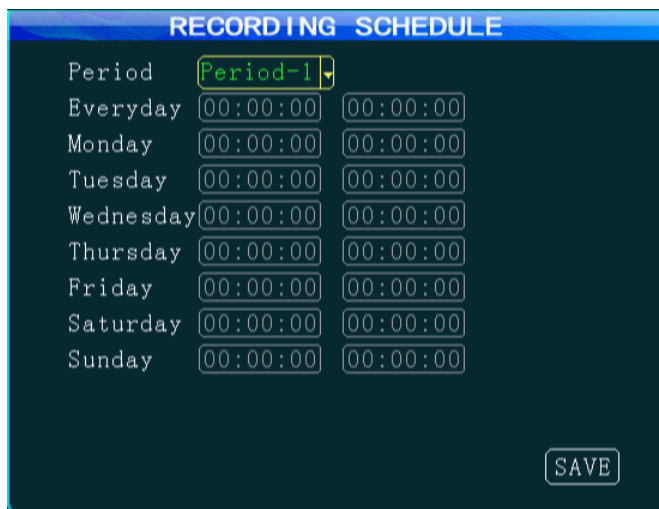

1. If the timer recording mode is selected in basic setting, it is needed to set a regular time period. Two time periods can be chosen. Move the cursor to the desired time period, then input by pressing the number keys on the remote control. Timer recording mode is not commonly used. customers can use it according to actual situation. Most customers chose to boot recording and alarm recording.

5.5 Mirror Record(Optional)

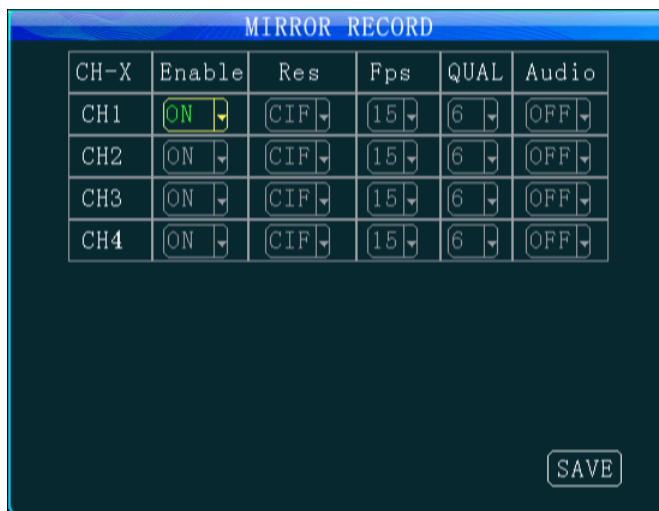

Description: Mirror record is used as a record backup to prevent record missing issue caused by hard disk error, the parameter setting can refer to the main code parameter settings.

5.6 SD Record



Description: when the hard disk does not exist due to vibration or other reasons, the record files will be stored onto SD card if you turn on the SD record function.

5.7 Alarm Record (Not support temporarily)

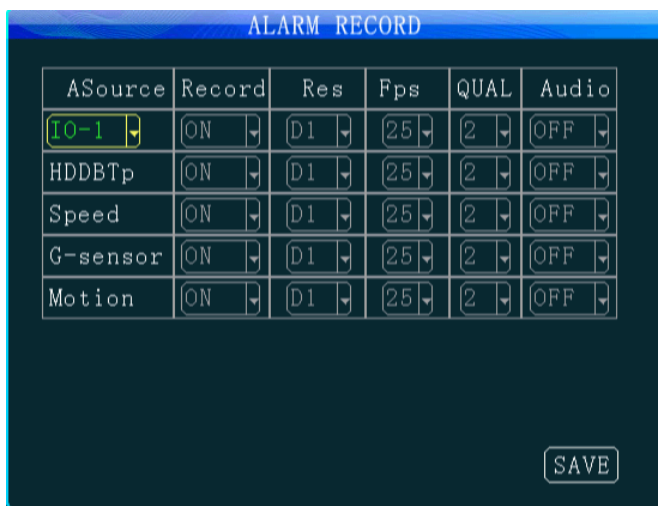

Description: Under normal circumstances, for example: you can set the resolution of the main code to be HD1 or CIF, frame rate set to be 10, the quality set to be 4, when alarm triggers recording, alarm recording can start in accordance with the set high-quality video parameters.

1. Corresponding record “On” means the corresponding alarm recording function is on.
2. Optional resolution D1/HD1/CIF.
3. Frame rate: PAL with frame 1-25, NTSC with frame 1-30.

4. Adjustable video quality:1-8. 1 is best.

5. Audio: this can be set whether to open the audio of the record, if on, then the audio will be recorded into the record file.

5.8 Speed Record(Optional)

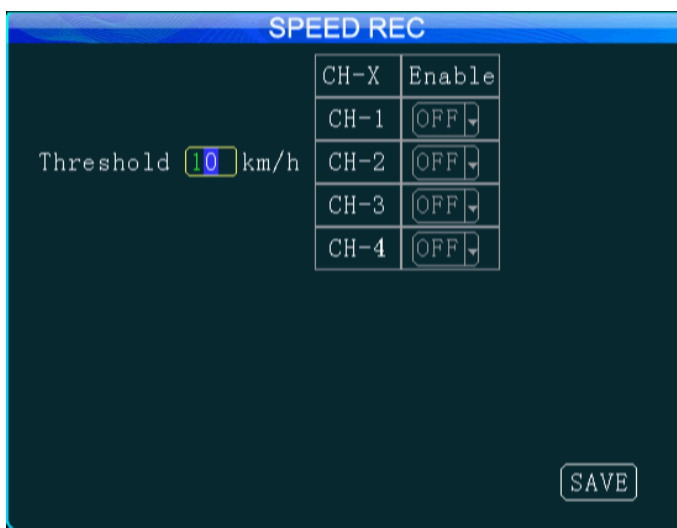

1. Set the speed threshold of recording.
2. Set the four-channel record enabled, on means open the record while off means close the record.
3. When the speed exceeds the speed threshold, the channel will not record with enable off, only channel with enable on will record.

6. Alarm settings

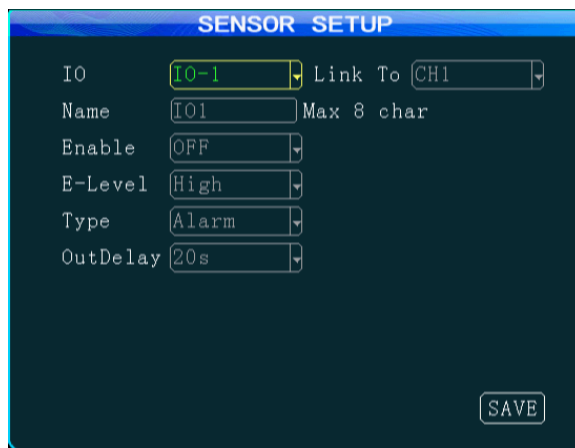

6.1 Sensor Settings

1. IO & Name: Users name the custom sensor according to the IO interface when install MDVR. for example, to change the name "IO1" to be Chinese 'front door, brake' etc. you can press the 'ENTER' key and then input under the soft keyboard state.
2. Link to:_When an alarm is triggered, the monitor screen automatically pop up enlarged channel (selected channel)
3. Enable on means this sensor turns on, the device supports up to 8 sensor inputs, these alarm input is generally connected to the circuit of car, such as door open/close button, brake lights, turn signals, etc., they are in effective when sensor input is high level , users generally use higher than 4V high level to trigger alarm. Note: less than 4V is low level.
4. When selecting type to be event, the record file is a normal record. when selecting the type of alarm, the record file type is alarm.
5. When an alarm is generated, it also can be sent to center CMSServer platform to record alarm information.
6. Out delay: When setting the alarm output on interface menu the of alarm linkage, the alarm is triggered off when the alarm output is set long delay.
7. IO Alarms can be transmitted to the center CMSServer platform.

6.2 Speed Settings

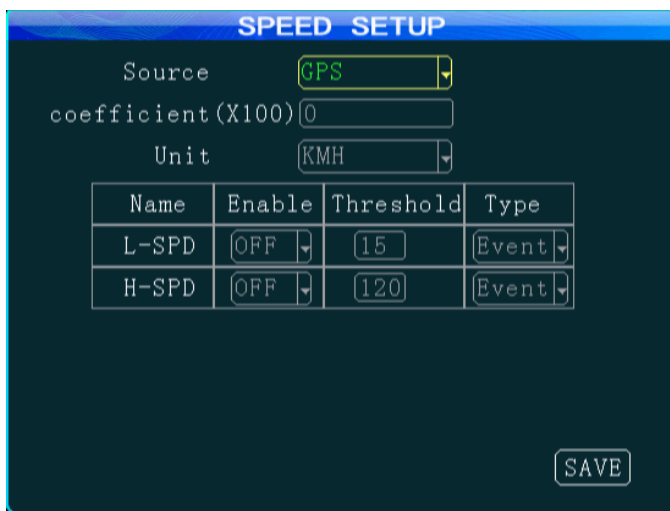

1. There are two options of Speed Source: "GPS" and "vehicle", if selecting the "GPS", the speed of the vehicle can only be sent to the device when the device has the GPS module and GPS signal, the vehicle can get the vehicle speed information by GPS.
2. If selecting the "vehicle" to get the speed, you need to connect to the pulse sensor to calculate the speed ratio (coefficient = pulse/speed*100), the pulse sensor connects to the device port SPEED-A and SPEED-B two lines, and the speed ratio is measured

according to the set speed and pulse getting during vehicle traveling.

3. Speed unit KM / MPH can be switched, high-speed limit threshold means the maximum speed of the speed limit, if you turn on the alarm, the alarm will be generated when the speed exceeds the threshold, alarm information can also be transmitted to center CMSServer platform for recording.

4. When selecting type to be event, the record file is a normal record. when selecting the type of alarm, the record file type is alarm.

5. Speed Alarms can be transmitted to the center CMSServer platform.

6.3 G-Sensor Settings

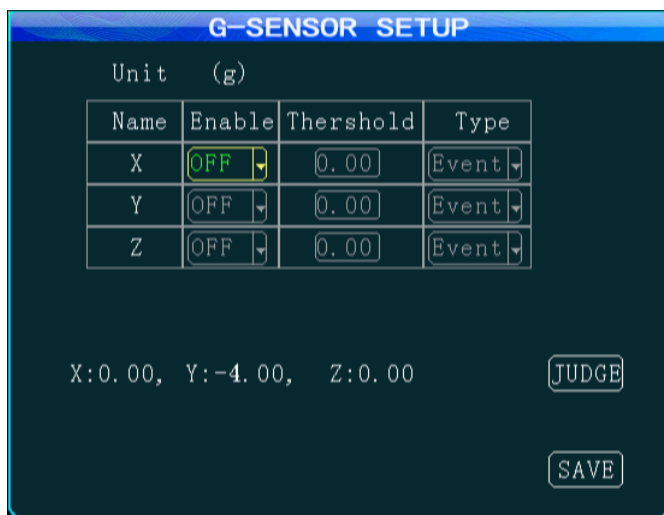

1. Enable on means this sensor turns on.
2. Calibration is required before G-Sensor setting. calibration is to clear X/Y/Z parameters. G-Sensor can be understood as a three-dimensional X/Y/Z axis, which respectively stands for three groups of states: upper and lower, left and right, front and rear, uniform has no effect, and the G-Sensor setting is mainly to set a threshold value, which needs to be determined. Generally speaking vehicle's instant acceleration is relatively large in case of slam the brakes on, crash, acceleration and sharp turns, whose

intuitive reflection is threshold beating, and PC displays X/Y/Z three states by waveform when playing back. When an alarm is generated, it also can be sent to center CMSServer platform to record alarm information.

3 When selecting type to be event, the record file is a normal record. when selecting the type of alarm, the record file type is alarm.

4. Shocking Alarms can be transmitted to the center CMSServer platform.

6.4 Temperature alarm

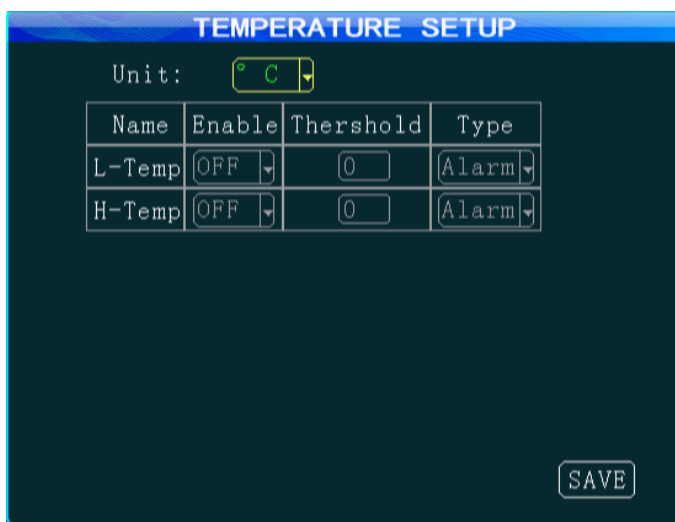

1. Two temperature degree units: Celsius °C and Fahrenheit °F.
2. Enable on means this sensor turns on.
3. Temperature is sent back to the device by a temperature sensor. As long as you set high or low temperature alarm threshold and turn on enable, when the temperature is above or below the threshold, the device generates an alarm, which can also be transmitted to center of CMSServer platform to record alarm information.
4. When selecting type to be event, the record file is a normal record. when selecting

the type of alarm, the record file type is alarm.

5. Temperature Alarms can be transmitted to the center CMSServer platform.

6.5 Motion Detection

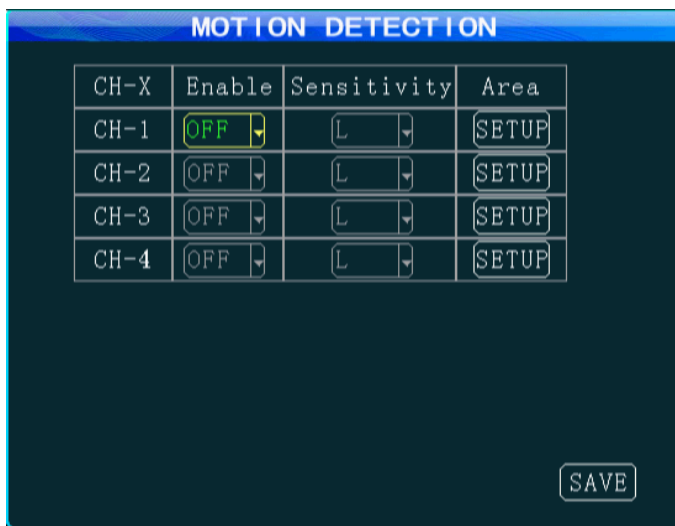

1. Enable on means this sensor turns on.
2. The sensitivity can be set L (low), M (medium), H (high), the higher the easier to detect environmental change.
3. Detection area: using two points of the diagonal to determine the detection area, select the first point, press ENTER on remote, and then use the up, down, left and right arrow keys on remote to select another point of the diagonal, press enter key again within selected area can cancel this area selecting.
4. Alarms can be transmitted to the center CMSServer platform.

Note: Motion detection can generate an alarm based on any change of the environment (including brightness, color, etc.). It is not recommended to use this alarm function in ordinary circumstances.

6.6 Linkage Settings

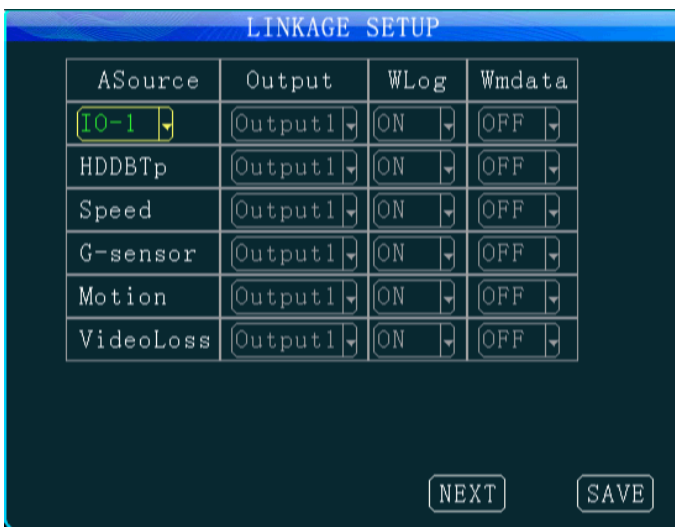

1. Select the output (output selectable output, output 1, output 2) in the corresponding column. after selecting the output, when an alarm is generated, the corresponding alarm output line will generate 12V high level to drive the work of other equipment.
2. It can also be chosen whether to record the Wlog, Wdata. on means recording, off means not recording.

7. TOOLS

7.1 Parameter configuration

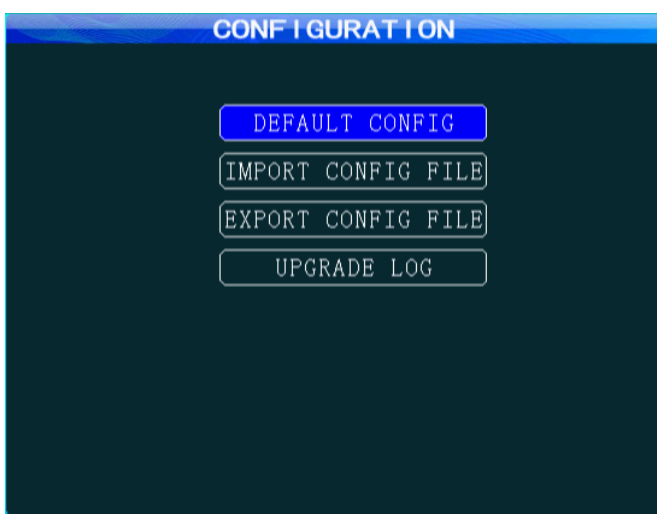

1. When the device parameters are in confusion, equipment can restore the default configuration to go back to factory settings.
2. Inserting USB storage device to the front USB port, the USB configuration files can be imported into this device.
3. Inserting the USB storage device to the front USB port, the current configuration parameters of this device can be imported into the USB storage device to become a parameter which can be imported to use.
4. The users can modify boot logo and upgrading logo according to their own needs.

- a. Logo image size: 720 * 576pix, Less than 256KB, name and format: loading.jpg(boot logo), upgrading.jpg(upgrade logo).
- b. Copy the 2 logo images to the USB flash thumb drive directly at same time, plug it into the USB2.0 port.
- c. Turn off 3G wireless module and wifi module: login---PERIPHERALS---WIRELESS SETUP---Wireless and WIFI SETUP set to OFF, then press save button.
- d. Login the MDVR:TOOLS---CONFIGURE---UPGRADE LOG. Need about 20S. it will be prompted to "upgrade logo success"

7.2 Format



Format HDD/SSD,USB, SD Card

It can be chosen to format the hard disk, mirror disk, SD card and USB.

Note: the hard disk must be formatted when inserts to the device by the first time.

7.3 Log Search

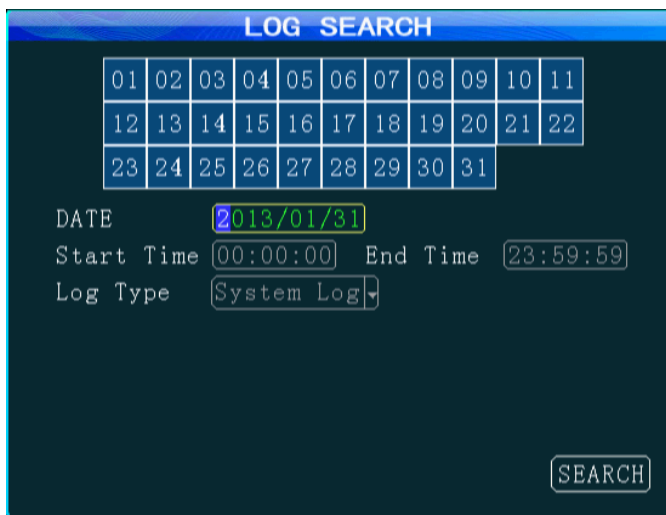

Calendar with green background means it has log, log query starts by selecting the date, start time, end time, log type: system log, alarm log. Such as on & off, video loss, parameter setting.

8. Peripheral Settings

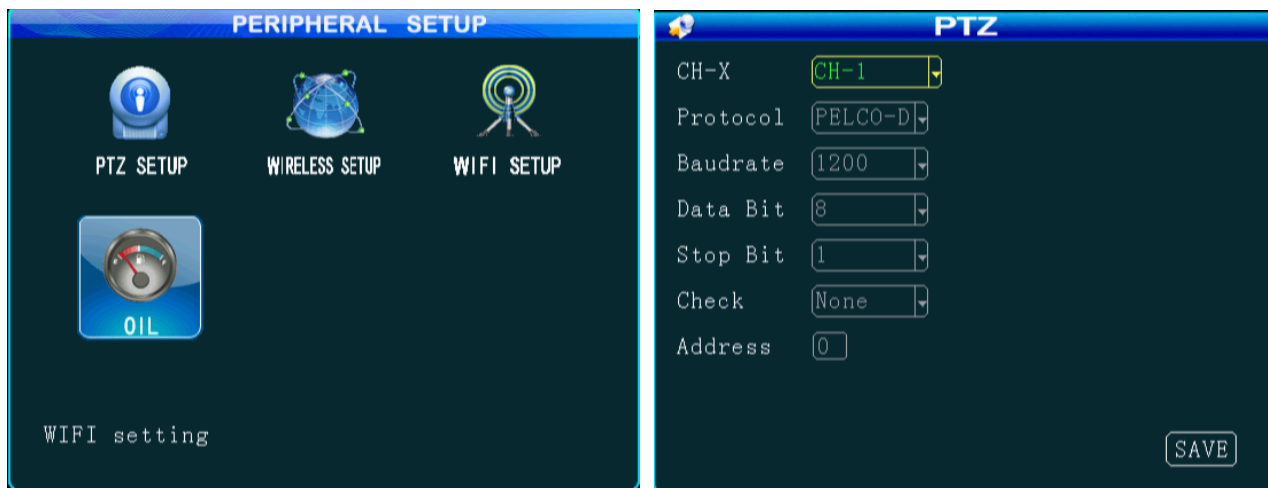

8.1 PTZ Settings

1. Channel selection 1-4 or 1-8
 2. Protocol: divided into PELCO-D and PELCO-P protocol
 3. Baud rate: 1200/2400/4800/9600 four options, the user can modify baud rates according to different PTZ setting.
 4. Data bit: Generally it is 8, where you can select from 1 to 8, but it is 8 by default.
 5. Stop bit: Stop bit is generally 1, you do not need to modify default.
 - 6 Check: check bit is to select the check way. Generally it is chosen to be None.
 - 7 Address: the address code is input directly by the address corresponding to PTZ setting, they must be setting corresponding to, the default address code of most PTZ is 1. PTZ has adjustable address code DIP, and it is needed to set different address codes to identify when there are numbers of PTZ.
 8. Wiring method: PTZ cathode connected to RS485-A, negative connected to RS485-B.
- When PTZ relevant parameters are set ready, the remote control can only be used to control PTZ after the channel connected to PTZ is selected, for example, PTZ is connected to Channel 2, then you can

only control it by switching to 2-channel to maximize it on the monitor interface.

8.2 3G/4G settings



Description: When the MDVR wants to use 3G/4G network reporting platform, it needs network-related settings in this menu.

1. According to the communication configuration of the machine, insert the SIM card, supporting 3G/4G: WCDMA/EVDO/TD-SCDMA, FDD-LTE/TDD-LTE. SIM card slot is on the front panel, open the lock to open the protective cover, you can see the SIM interface, follow the instructions to insert the SIM card correctly.

2. Plug in the 3G/4G antenna after SIM card

inserting, ensuring that the system is able to receive good 3G/4G signal.

3. Edit the image information under the 3G/4G Settings menu interface:

A: Wireless set to open.

B: Select the type of communication, press "ENTER" button to select the corresponding module (WCDMA / EVDO / TD-SCDMA / FDD-LTE/TDD-LTE) is determined by the type of model, one model only support one mode.)

C: The access point and the centre number is generally by default, which do not need to change. user name and password in some provinces are not by default, some can be empty which do not need to input anything, while most of them can just keep the default settings. If it is a foreign 3G/4G, it would need the operators to provide access points and centre number to set, in some abroad places it is a must to enter username and password for a normal dial-up. when your host can not be reported, please make sure your 3G/4G settings are correct (most of the foreign districts are with WCDMA equipment)

D: Save it after completing all the settings.

4. After exiting all menus, press the INFO button on the remote control, it is able to see 3G/4G communication, if signal is good, it will show dial-up is successful, the device can be reported to CMSServer platform with three points of the server IP address settings, port settings and device number settings.

8.3 WIFI Settings

1. Select WIFI module to be internal or external.

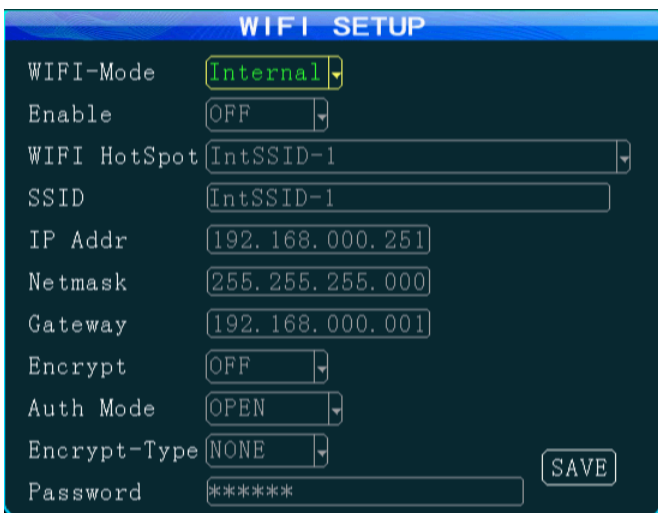

2. Select enable to be on.
 3. Internal WIFI: Hot switch can support multiple connections. Please refer to the router parameters.
 External WIFI. Input the IP address of AP-WiFi, note: the device to determine whether the RJ45 interface and external module is connected by IP. Input AP-WiFi's SSID, note: the server to determine whether to use the WIFI connection by this SSID.

8.4 Oil settings



Need to connect a special oil sensor.(the sensor that MDVR must be able to identify the protocol oil sensor)
 ID: Select the oil sensor type.
 Enable: ON
 Tank corresponding scale Per oil
 Oil alarm Value.

9.Record Search

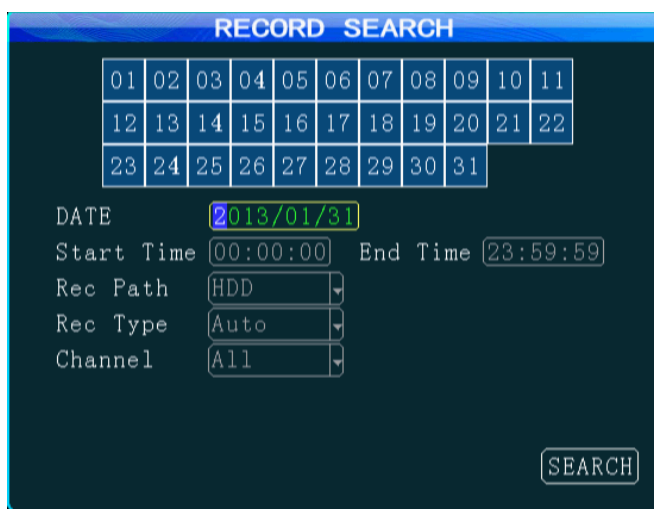

Calendar with green background means it has video file, video search starts by selecting the date, start time, end time, record path: hard drive, mirror, SD card, record type: conventional recording, alarm recording, all recording, channels: all channels, 1-4, 1-8. After searching, select it and click remote play button for record playback,. pressing the number keys 1-8 on the remote control can switch to the single-channel full-screen playback, supporting 2X/4X/8X /16X speed fast forward and rewind.

10. System Info

View the device status from system information

The left screenshot displays the following system information:

```

SYSTEM INFO
SW Ver: T14040101      MCU Ver: V403193
HW Ver: JH4-M-V001    GPS-M: VALID
GPS-sign: N22.33.390966 E113.56.229101
Speed: 0km/h          Speed-Plus: 0
HDD Temp: 34°C
SIM-Card: EXIST       SIM-sign: 10
3G-M: EXIST          3G-State: OK
WIFI-M: NONE         WIFI-sign:
Center-L: LINK SUCCEEDED
INTERCOM: NONE       INTERCOM-L: NO LINK
IO-State: 1:L 2:L 3:L 4:L 5:L 6:L 7:L 8:L
Serial-Num 00-00-00-00-00-00-0c-8d
IMEI:
    
```

The right screenshot displays the following storage and system information:

Storage	Total	Used	Free	State
HDD	488.3G	192.1G	296.2G	NORMAL
MIRROR	0.0G	0.0M	0.0M	NONE
SD	8.0G	0.3M	8.0G	NORMAL

Below the table, the right screenshot shows:

```

IC EXIST: NONE      IC CONN: NO LINK
Vehicle Mileage: 0.00 KM
    
```

At the scene to monitor the status of the four screens, pressing the "INFO" button on the remote control can directly display system information, device status information includes the hardware and software version number, and the MCU version information, meanwhile display GPS module, WIFI module, 3G wireless module and SIM card, intercom state, IO state, IMEI information, the device status information is often used when checking the system status and fault judgment. When it needs 3G/4G to report CMSServer platform, the 3G/4G card signal and dial-up state are visually displayed here, and the success/failure status of connecting to the server center can be also displayed.

The next page of System Information can view the hard disk, the mirror disk, SD card: total capacity, used space, free space, state. IC card state. Vehicle mileage. You must use admin account to login MDVR when you want to reset the vehicle mileage.

Appendix 1: CMSServer platform interface



Appendix 2: Common problems and treatment

Q: What can I do when I found a problem with the product, but I can't solve it by myself?

A: Take note of the model and software version number, then submit a detailed description of the problem to the Technical supporting engineers to analyze. the more detailed you have submitted, the more convenient for us to analyze.

Q: How about when there is no video output from the vehicle host device?

A: 1.Check the host's turn-on status, if only a blue light on, it means the host is in standby status and has not been started up yet, meanwhile check whether the host's power cords red & yellow cords are in power supply status or not, if only one cord is supplying power, the device is unable to start up.

2.Check the power supply status of display screen, as well as check whether the display video has been switched to AV status.

3 Check the connecting status between the host's video output cable and display screen.

4 check whether the lock status of the host's LOCK, it must be locked before normal starting up.

Q: How to do when the car host video input interface is different from the camera output interface?

A: The car uses 4PIN type while camera uses BNC or aviation head type, if not in correspondence, please use conversion head for connection or wiring based on standard corresponding according to the cable sequence defined by the car host.

Q: How to do when the device does not conduct video recording after it is turned on and SD card has already been installed?

A: 1.Check whether the SD card has been formatted or not after installation, because unformatted SD card cannot be used. Enter System Menu - System Tools - Device Format to format the newly installed SD card.

2. Check to see whether video channel is closed or not, whether set a timer recording or not, it will not

take video when it is not within the video recording time period.

3. Check the SD card inserting status and whether the SD light on front panel is on or not.

Q: The video file is missing or there is no video file within a certain period of time, how to do?

A: 1. Determine the time period by analyzing the final video file before missing and the first video file after recovery.

2. Confirm whether the host is not on during that period of time, such as when the driver halfway parking, loading and unloading goods while the host is not set by video delay.

Q: When car PTZ cannot be controlled, it cannot rotate up and down, how to do?

A: Check whether PTZ protocols and baud rate are set correct, address codes are corresponding or not, whether have selected to maximize the video of the channel when control the PTZ, for example, when control the second channel, it must maximize the screen of the second channel image to control it.

GPS-related issues

Q: GPS module exists but no coordinate information?

A: 1. Check whether GPS module exists, if it does not exist, check whether the hardware is installed or in a good contact.

2. Make sure that the GPS antenna contacts are good, whether the antenna is broken, it is recommended to be located in places with strong signal, note that some car glass shielding film will block GPS signals.

3. If the test is in the room, the signal of GPS antenna in the room will be obscured, it is recommended that the GPS antenna is placed outdoor.

Q: Deviation of GPS location on map?

A: It means the signal is valid if the GPS module already positioned, there may many reasons for the deviation, such as government restrictions, permissible error, GPS signal interruption, etc. the actual satellite map may have deviation for security reasons, general map can solve the problem by using GPS correction.

3G wireless module

Q: If use the 3G/4G wireless module for dial-up, what do I need to pay attention to?

A: 1. Choose the built-in wireless module WCDMA / EVDO / TD-SCDMA / FDD-LTE/TDD-LTE, corresponding module settings are not the same, the modules supported by different machines models are not the same, so please make sure whether your module and SIM is in correspondence. Do not use EVDO SIM card on WCDMA machine.

2. Check whether the settings of Server IP and port are correct, whether 3G/4G signal is strong enough for dialing, and then check whether the 3G/4G dial-up is successful or not.

3. When dialing is unsuccessful, please check 3G/4G antenna is in good contact or not, the dial up may fail because of weak signal, moreover, please check whether the SIM card has enough traffic, if no traffic, dial-up will be unsuccessful.

Q: When 3G/4G has neither report nor video, what should be done first?

A: Press INFO key to enter the system information page, check whether the SIM card exists and view the signal strength as well as dial-up status, whether the antenna is in good contact, and then check the SIM to see whether it is out of traffic, the most basic judgment is to replace the SIM card. If the dial up failed with signal, then check whether the settings of center number and the port are correct. Moreover check whether the device number of the product is already occupied.

Q: 3G/4G signal is intermittent, video is jammed?

A: At present the signal coverage of WCDMA / EVDO / TD-SCDMA / FDD-LTE/TDD-LTE is rather wide,

however, there are some mountainous districts without signal coverage, and some suburban areas have weak signal due to the local network constraints, then it will be jammed during watching of video, or video cannot be watched at all, the greatest impact of this situation is from the local network. Moreover check whether the frame rate setting of sub-stream is too high, because the video may also occur such situation when the network is poor and frame rate setting is high.

Q: Why the vehicle and video cannot be seen in CMSServer client when the device has been started?

A: At first make sure the central registration server is switched on and on the net, then check whether the host device number has been occupied to cause conflict, secondly check whether the settings of server-centric IP and port are correct. devices report to the center via the built-in 3G/4G module or via WIFI. If via built-in 3G/4G, please check whether selected the correct type of built-in 3G/4G module, for example, WCDMA and EVDO module needs the support from corresponding SIM card, check whether the antenna is in good contact. If it still can not report when above all are checked, enter into the system information page to view dial-up. If dial-up is not successful, look up whether the setting of data access point and center number is correct. If all ultimately fail, please collect as much information as possible to submit to the technical supporting staff for analysis, the more data provided, the more convenient for technicians to solve the problem.

Q: The device is online, but why can I not see the video image?

A: Please set lower sub-stream to transmit image, the blocked or slow transmission speed situation may occur when the sub-stream frame rate is set very high and be affected by network uploading limit. poor network signal or intermittent will seriously affect the video transmission.

Q: The device is properly reported on CMSServer, but the videos cannot be seen after using for some time?

A: Firstly check whether the host side displays dialing, if it keeps the dialing status, it may be because the flow of the SIM card has run out, replace the SIM card to test. Secondly query whether the host device number has been modified by the driver, the host with modified device number needs to be resubmitted to add vehicle information. thirdly, if it still does not work by changing the card, it will need to check whether the host's 3G/4G module fails.

Appendix 3:storage space corresponding table

Appendix 3: storage space corresponding table

	Quality Resolution	1	2	3	4	5	6	7	8
RECORDING SPACE M/H	D1	900	670	540	450	390	350	315	280
	HD1	560	420	335	280	245	220	195	175
	CIF	350	260	210	175	150	135	120	110

The space occupying for each image video recording per hour is shown as above table which is for reference only, the actual video file size has something to do with light changes of the current channel, movement of object and many other factors, if the image is stationary, then video file size will be much smaller; in order to save space, it can be set to turn off the audio or turn off the channel without video.

Appendix 4:MDVR Before loading the tool to check

Equipment installation before the installation is required to prepare the necessary installation tools, common tool types in the table below:

NO.	NAME	Specification	Explanation
1	Multimeter	On request	To test the circuits
3	Drill	On request	For punch
4	Remote control	Special	For debugging host
5	Test pencil	On request	For detecting circuit
6	Display	Special	For debugging host
7	Wire strip	On request	For stripping
8	Screwdriver	On request	For equipment fixed
9	Hex wrench	On request	For equipment fixed
11	Tape measure	On request	For measuring
12	Openings	On request	For openings
13	Pliers	On request	For the cut line
14	Power granted	On request	For equipment fixed

Appendix 5:MDVR Before loading the installation of auxiliary examination

Equipment installation before the installation to be complete some of the necessary installation accessories, accessories category in the table below:

NO.	NAME	ICON	NO.	NAME	ICON
1	POWER LINE		2	ACC LINE	
3	Self-tapping screws		4	Line deduction	
5	Ties		6	Flame retardant corrugated pipe	
7	Insulating electrical tape				