



SPSKLIMA
Strategic Products and Services

INSTALLATION MANUAL

Two-way Cassette Type

Digital Scroll and DC/AC Inverter Commercial Air-conditioner

The Digital Scroll and DC/AC Inverter share the same indoor units.

Thank you very much for purchasing our air conditioner,
please read this manual carefully and keep it for future reference.

CONTENTS

PAGE

1. PRECAUTIONS.....	1
2. INSTALLATION INFORMATION.....	2
3. ATTACHED FITTINGS.....	3
4. INSTALLATION.....	4
5. LAYOUT THE DRAIN PIPE.....	7
6. INSTALL THE CONNECTING PIPE.....	8
7. WIRING.....	10
8. CONTROL OPERATION.....	12
9. TEST OPERATION.....	14

1. PRECAUTIONS

- Be sure to be in conformity with the local, national and international laws and regulations.
- Read "PRECAUTIONS" carefully before installation.
- The following precautions include important safety items. Observe them and never forget.
- Keep this manual with the owner's manual in a handy place for future reference.

The safety precautions listed here are divided into two categories. In either case, important safety information is listed which must be read carefully.



WARNING

Failure to observe a warning may result in death. The appliance shall be installed in accordance with national wiring regulations.



CAUTION

Failure to observe a caution may result in injury or damage to the equipment.

After completing the installation, make sure that the unit operates properly during the start-up operation. Please instruct the customer on how to operate the unit and keep it maintained. Also, inform customers that they should store this installation manual along with the owner's manual for future reference.



WARNING

Be sure only trained and qualified service personnel to install, repair or service the equipment.

Improper installation, repair, and maintenance may result in electric shocks, short-circuit, leaks, fire or other damage to the equipment.

Install according to this installation instructions strictly. If installation is defective, it will cause water leakage, electrical shock fire.

When installing the unit in a small room, take measures against to keep refrigerant concentration from exceeding allowable safety limits in the event of refrigerant leakage. Contact the place of purchase for more information. Excessive refrigerant in a closed ambient can lead to oxygen deficiency.

Use the attached accessories parts and specified parts for installation. otherwise, it will cause the set to fall, water leakage, electrical shock fire.

Install at a strong and firm location which is able to withstand the set's weight. If the strength is not enough or installation is not properly done, the set will drop to cause injury.

The indoor unit must be installed 2.5m above floor.

The appliance shall not be installed in the laundry.

Before obtaining access to terminals, all supply circuits must be disconnected.

The appliance must be positioned so that the plug is accessible.

The enclosure of the appliance shall be marked by word, or by symbols, with the direction of the fluid flow.

For electrical work, follow the local national wiring standard, regulation and this installation instructions. An independent circuit and single outlet must be used. If electrical circuit capacity is not enough or defect in electrical work, it will cause electrical shock fire.

Use the specified cable and connect tightly and clamp the cable so that no external force will be acted on the terminal.

If connection or fixing is not perfect, it will cause heat-up or fire at the connection.

Wiring routing must be properly arranged so that control board cover is fixed properly.

If control board cover is not fixed perfectly, it will cause heat-up at connection point of terminal, fire or electrical shock.

If the supply cord is damaged, it must be replaced by the manufacture or its service agent or similarly qualified person in order to avoid a hazard.

An all-pole disconnection switch having a contact separation of at least 3mm in a poles should be connected in fixed wiring.

When carrying out piping connection, take care not to let air substances go into refrigeration cycle. Otherwise, it will cause lower capacity, abnormal high pressure in the refrigeration cycle, explosion and injury.

Do not modify the length of the power supply cord or use of extension cord, and do not share the single outlet with other electrical appliances. Otherwise, it will cause fire or electrical shock.

Carry out the specified installation work after taking into account strong winds, typhoons or earthquakes.

Improper installation work may result in the equipment falling and causing accidents.

If the refrigerant leaks during installation, ventilate the area immediately.

Toxic gas may be produced if the refrigerant comes into the place contacting with fire.

After completing the installation work, check that the refrigerant does not leak.

Toxic gas may be produced if the refrigerant leaks into the room and comes into contact with a source of fire, such as a fan heater, stove or cooker.

The temperature of refrigerant circuit will be high, please keep the interconnection cable away from the copper tube.



CAUTION

Ground the air conditioner.

Do not connect the ground wire to gas or water pipes, lightning rod or a telephone ground wire. Incomplete grounding may result in electric shocks.

Be sure to install an earth leakage breaker.

Failure to install an earth leakage breaker may result in electric shocks.

Connect the outdoor unit wires, then connect the indoor unit wires.

You are not allowed to connect the air conditioner with the power source until wiring and piping the air conditioner is done.

While following the instructions in this installation manual, install drain piping in order to ensure proper drainage and insulate piping in order to prevent condensation.

Improper drain piping may result in water leakage and property damage.

Install the indoor and outdoor units, power supply wiring and connecting wires at least 1 meter away from televisions or radios in order to prevent image interference or noise.

Depending on the radio waves, a distance of 1 meter may not be sufficient enough to eliminate the noise.

The appliance is not intended for use by young children or infirm persons without supervision.

Young children should be supervised to ensure that they do not play with the appliance.

Don't install the air conditioner in the following locations:

- There is petrolatum existing.
- There is salty air surrounding (near the coast).
- There is caustic gas (the sulfide, for example) existing in the air (near a hot spring).
- The Volt vibrates violently (in the factories).
- In buses or cabinets.
- In kitchen where it is full of oil gas.

- There is strong electromagnetic wave existing.
 - There are inflammable materials or gas.
 - There is acid or alkaline liquid evaporating.
 - Other special conditions.
-

2. INSTALLATION INFORMATION















- **To install properly, please read this "installation manual" at first.**
 - **The air conditioner must be installed by qualified persons.**
 - **When installing the indoor unit or its tubing, please follow this manual as strictly as possible.**
 - **If the air conditioner is installed on a metal part of the building, it must be electrically insulated according to the relevant standards to electrical appliances.**
 - **When all the installation work is finished, please turn on the power only after a thorough check.**
 - **Regret for no further announcement if there is any change of this manual caused by product improvement.**
-

INSTALLATION ORDER

- Select the location;
- Install the indoor unit;
- Install the outdoor unit;
- Install the connecting pipe ;
- Connect the drain pipe;
- Wiring;
- Test operation.

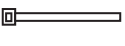
3. ATTACHED FITTINGS

Please check whether the following fittings are of full scope. If there are some spare fittings , please restore them carefully.

Accessory name	Qty.	Shape	Usage
Installation & Owner's Manual	1	This Book	Indoor Unit Installtion Instruction(Please Do Hand to User)
Heat-insulated Pipe	2		Use for heat-insulating of pipe connecting parts
Protection Pipe	1		Use for heat insulation of flexible pipe
Matched Resistance(also Network Matching Wiring Group)	1		Improve the stability of communication
Bolt	4		Fix the installation template paper
Nut	8		Hanging component
Washer	8		Hanging component
Flexible Pipe	1		Drain piping
Remote Controller Installation Instruction	1		Remote controller instruction
Remote Controller Components	1		Remote control the air-conditioner
Installation Template Paper	1		Assist the indoor unit installation(in the installation of the panel)
Drain Pipe Clasp	1		For drain pipe installation
Lacing Belt	5		_____
Attached Foam I 250×250×10	1		Heat insulation
Attached Foam II 60×100×5	1		Heat insulation
Battery	2		Power supply for remote controller

Cautions on remote controller installation:

- Never throw or beat the controller.
- Before installation, operate the remote controller to determine its location in a reception range.
- Keep the remote controller at least 1m apart from the nearest TV set or stereo equipment. (it is necessary to prevent image disturbances or noise interferences.)
- Do not install the remote controller in a place exposed to direct sunlight or close to a heating source, such as a stove.
- Note that the positive and negative poles are right positions when loading batteries.
- This manual is subject to changes due to technological improvement without further notices.

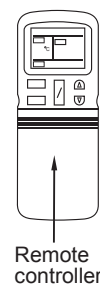

Fig.3-1

4. INSTALLATION

4.1 Installation place

The indoor unit should be installed in a location that meets the following requirements:

- There is enough room for installation and maintenance.
- The ceiling is horizontal, and its structure can endure the weight of the indoor unit.
- The outlet and the inlet are not impeded, and the influence of external air is the least.
- The air flow can reach throughout the room.
- The connecting pipe and drainpipe could be extracted out easily.
- There is no direct radiation from heaters.
- This air-conditioner should install on the 3m high ceiling.

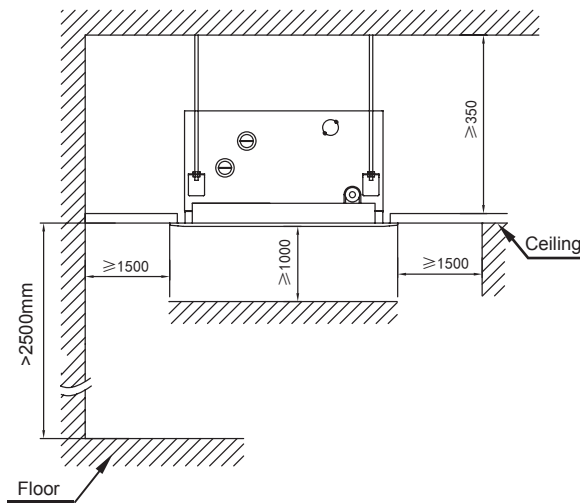

CAUTION

Installing the equipment in any of the following places may lead to faults of the equipment (if that is inevitable, consult the supplier):

- A. The site contains mineral oils such as cutting lubricant.
- B. Seaside where the air contains much salt.
- C. Hotpring area where corrosive gases exist, e.g., sulfide gas.
- D. Factories where the supply voltage fluctuates seriously.
- E. Inside a car or cabin.
- F. Place like kitchen where oil permeates.
- G. Place where strong electromagnetic waves exist.
- H. Place where flammable gases or materials exist.
- I. Place where acid or alkali gases evaporate.
- J. Other special environments.

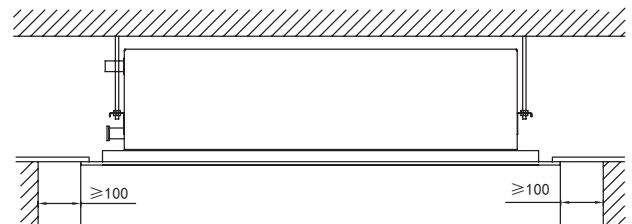

Fig.4-1

4.2 Preparation of installation

4-2-1 The position relation graph of the ceiling opening and the hanging screw.

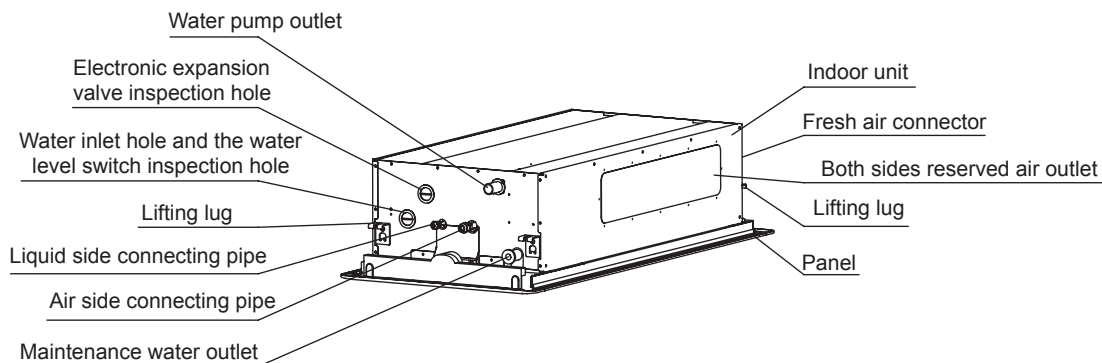

Fig.4-2

Unit: mm

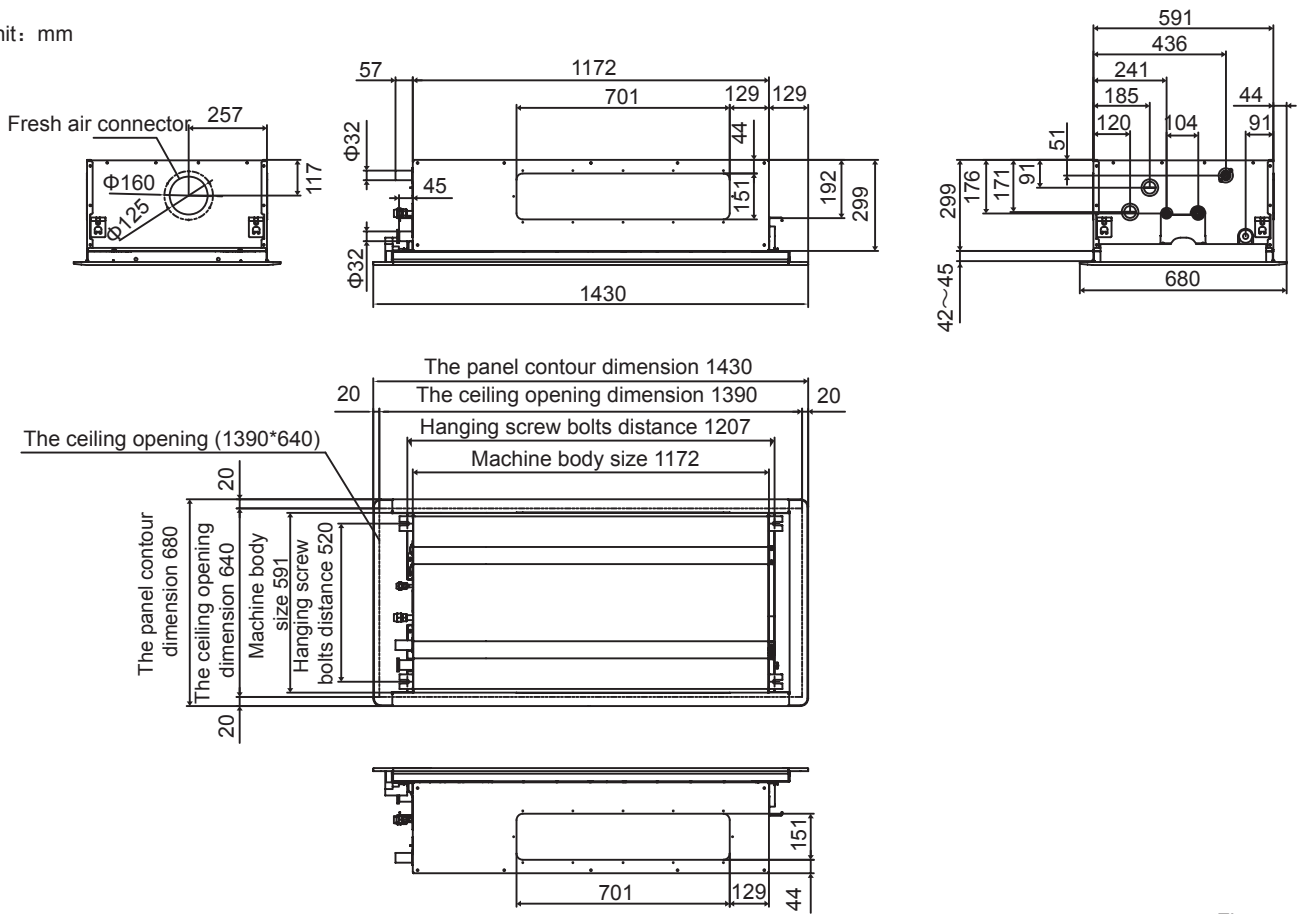

Fig.4-3

4-2-2 Open the ceiling on the proper place.

■ The relative position relation of the ceiling and air-conditioner

1) The ceiling opening: The opening dimension please refers to the panel attached installation template paper; for different building structure, the actual situation please consults with the architecture interior decoration personnel.

2) Disposal of the ceiling: To make sure the horizontal of the ceiling and avoid the ceiling vibration, the base frame of the ceiling must be strengthened.

3) Cut off and remove the base frame of the ceiling.

4) Strengthen the end face which left after take off the ceiling, and strengthen the base frame use for fixing the both sides of the ceiling.

5) After installing the main body, then piping and wiring in the ceiling, and then decide the piping leading out direction after selecting the installation location.

Especially in the situation where already has ceiling, please wiring the refrigerating pipe, drain pipe, indoor and outdoor units connecting wire and line-controlling wire to the connecting positions.

6) Please use M10 hanging bolt.

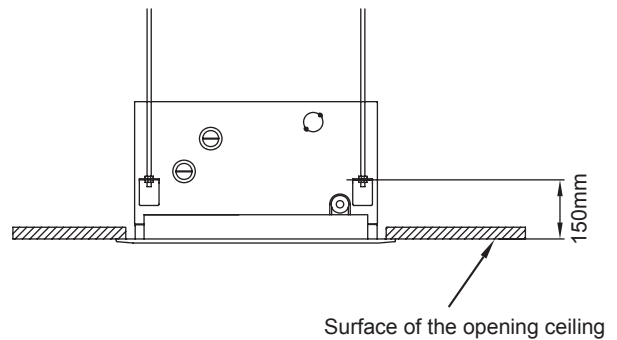

Fig.4-4



NOTE

All the pictures in this manual are for explanation purpose only. They may be slightly different from the air conditioner you purchased(depend on model).The actual shape shall prevail.

4.3 Indoor unit installation

- Overhanging the indoor unit
- Adjust the gasket (down side) to 150mm over the ceiling .

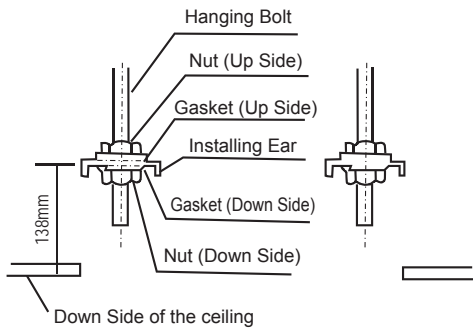

Fig.4-5

- Fasten the upside nut

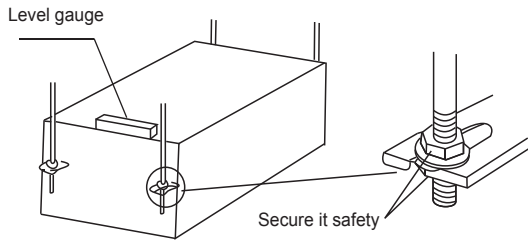

Fig.4-6

- Install the hanging bolt into U groove of the hanging tool. Overhang the indoor unit and ensure it is level using a level gauge.
- Adjust the relative position between indoor unit and ceiling hole with the pattern paper again.

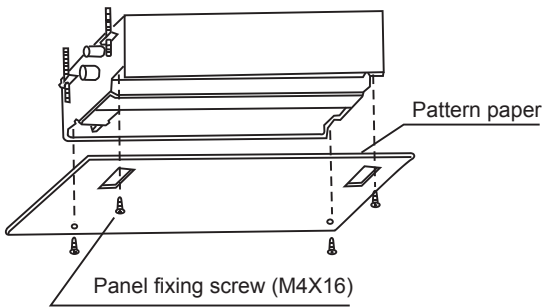

Fig.4-7

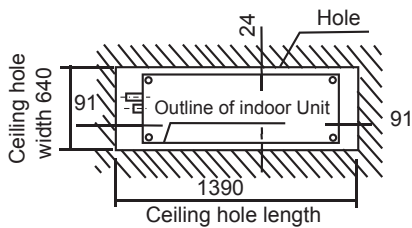

Fig.4-8

- Fix the pattern paper to the down side of indoor unit with panel fixing screw. Adjust the size of ceiling hole according to pattern paper.

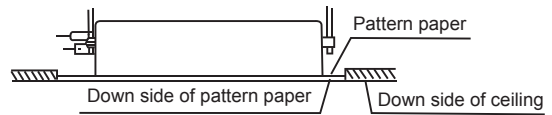

Fig.4-9

- Down side of ceiling must be level with down side of the pattern paper.

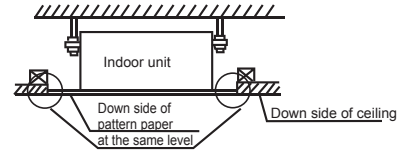

Fig.4-10

4.4 Procedure of installing the pendant bolt

Base on the unit structure, please set the screw-pitch according to the size of the following figures:

Table: 4-1

Wooden structure
<p>Put rectangular sticks across the beams, and set pendant bolts.</p>
Old concrete roughcast
<p>Use embedded bolts and embedded pulling plugs.</p>

Table: 4-2

Steel beam and girder structure	
Set and use supportive angle steel.	
New concrete roughcast	
Set it with embedded bushes or embedded bolts.	
<p>Flap type inser</p>	<p>Slide type inser</p>

3) Water-pumping pipe and drainpipe from main body must be wrapped by insulation tube evenly, and bound by tighten band for obstructing air getting in and coagulation.

4) Prevent from water backflow into unit inside during shutdown, the drain pipe shall place down side and drain water to outdoor (drain side), the gradient of the drain pipe should be higher than (1/100), without salient and water remain. (Refer to Fig.5-1 a)

5) When connecting drainpipe, don't drag the pipe that would pull the main unit. For this, please arrange bearing points every 0.8 to 1.0 meter to avoid pipe be bended (See Fig.5-1 b).

6) When connect a lengthen drainpipe, apply protective tube to wrap its indoor parts for ensuring the lengthen part connected tightly.

7) In case the drainpipe outlet is higher than pumping connective pipe of the main body, the drainpipe must be arranged upwards vertically by using connective assembly of the water outlet for vertical bending, and the height of the drainpipe shall set to the defrosting pan surface no more than 1000mm, otherwise, too much backflow while shutdown would leads to overflow (Refer to Fig.5-2).

8) Base on the actual requirement to bend piping, and use connective assembly of water outlet in terminal box for pipe layout.

5. LAYOUT THE DRAIN PIPE

5.1 Install the drain pipe of indoor unit

1) The drainpipe can use PVC pipe (external diameter about 37~39mm, inner diameter is 32mm).

2) Joint drainpipe connector to the end side of water pumping pipe, and fix drainpipe together with water outflow pipe and thermal insulation tube by clasp of water outflow pipe (attached).



CAUTION

Don't use forcing strength to crack the water-pumping pipe.



CAUTION

The joints in drain system must be sealed to avoid water leakage.

9) The height from floor to the end of drainpipe or the bottom of drain slot must more than 50 mm. Don't immerse the end of drainpipe or the bottom of drain slot into water. When drain condensate liquid to raceway, please bend the drainpipe to a U-shaped hydroseal for avoiding stench transmitted by drainpipe to indoor.

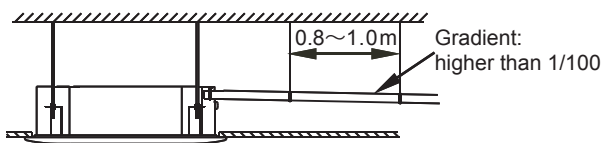

a ○

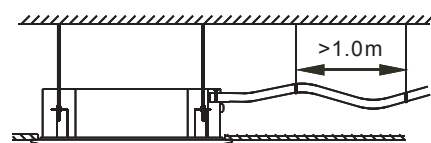

b ✕

Fig.5-1

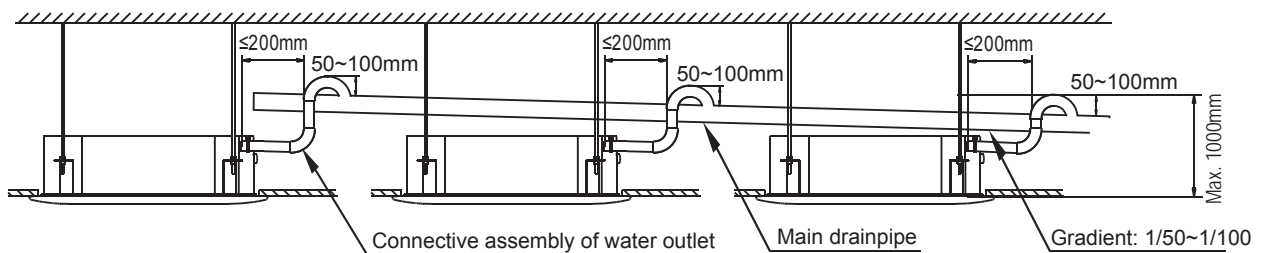

Drainpipes from many units confluent water to main drainpipe and discharge to cloacae.

Fig. 5-2

5.2 Confirm dewatering

- 1) Remove the water testing cover and through the water testing orifice, use the refilling pipe to fill 2000ml water into the water pond (refers to Fig.5-3).
- 2) Power on, and operate the cooling of the air-conditioner. Check the running sounds of the dewatering pump, and check the drain outlet whether can drain normally (depends on the time of draining, it will be delayed 1 minute then can drain), and check all the connectors whether leak or not.
- 3) Stop running the air-conditioner, and check whether has any abnormal situation after 3 minutes. If the drain pipe be laid out unreasonable, the water will backflow too much and cause the alarm lamp of the control box be flashed, or even overflow from the water pond.
- 4) Continue to fill water until the water level over alarm water level and stay on this state for 3 minutes, the machine will alarm and shut off, and then it can be operated normally until power off and remove the water.
- 5) Power off, and remove the water, then install the water testing cover back to the formal place.

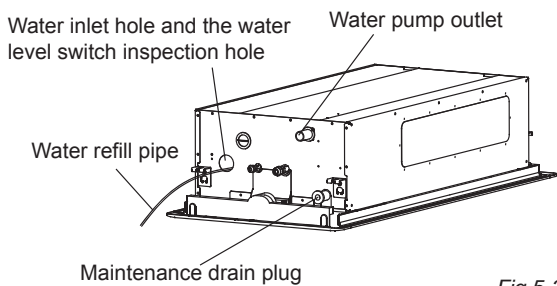

Fig.5-3



WARNING

The drain plug on the side of the main unit is using for dewatering the water pond when the air conditioner came out fault and maintaining, while using the unit please stuff this drain plug, for avoiding leakage. The specified position of the drain plug please refers to Fig.5-3.

6. INSTALL THE CONNECING PIPE

6.1 The connective length of indoor and outdoor piping and those height difference requirements.

Connect to different outdoor units with different connective length and height difference requirements. Please refer to Indoor Unit Installation Manual for detail.

6.2 Piping materials and size

- 1) Piping materials: Copper tube special for air conditioner, normally T2M.
- 2) Piping size: Please refer to Table: 6-1

Table: 6-1

Indoor unit model	Piping size (mm)	
	Liquid side	Air side
2200W~4500W	Φ6.4	Φ12.7
5600W~7100W	Φ9.5	Φ15.9

6.3 Procedure of connecting pipes

1. Measure the required length of the connective pipe, and make the connective pipes in the following procedure. (Refer to Pipeline Connection for details)

- 1) Connect the indoor unit first, and then connect the outdoor unit.
 - a. The pipe bend should be handled carefully, without damaging the pipe and insulation layer.
 - b. Before screwing up the flared nut, apply refrigerant oil at the outer surface of the pipeline flare and the taper surface of the connection nut. Screw up the nut for 3~4 circles beforehand (see Fig.6-1).

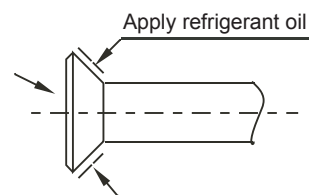

Fig.6-1

- c. When connecting or disconnecting the pipeline, be sure to use two spanners concurrently.
- d. Do not rest the weight of the connective pipe on the adapter of the indoor unit. Too heavy load on the adapter of the indoor unit may deform the pipe and thus affect the cooling/heating effect.

2) The valve of the outdoor unit should be closed completely (as in the factory status). Every time when connecting the pipe, screw off the nut at the valve, and connect the flared pipe (within 5 minutes). If the nut is put away for a long time after being screwed off the valve, dust and other foreign substance may intrude into the pipeline system and lead to fault.

- 3) After the refrigerant pipe is connected to the indoor and outdoor units, expel air as instructed in the "Expel air" section. After expelling the air, screw up the nut at the maintenance orifice.
 - a. Precautions for the flexible part of the pipeline
 - i. The bend angle shall not exceed 90°. (See Fig.6-2)

Use a thumb to bend the pipe



Minimum radius 100mm

Fig.6-2

- ii. The bend shall be preferably in the middle of the pipe length, and higher bend radiuses are preferred.
- iii. Do not bend the flexible pipe for over 3 times.

- b. Bend the thin-wall connective pipe (See Fig.6-3)



Method of unleashing the spooled pipe
Straighten the pipe end

Fig.6-3

- i. When bending the pipe, cut out a notch of the desired size at the bend of the adiabatic pipe, and then expose the pipe (wrap the pipe with the wrapping tape after bending it).
- ii. The radio of the elbow pipe should be as large as possible to prevent flattening or crush.
- iii. Use the pipe bender to make close elbow pipe.

c. Use purchased copper pipe

When the cooper pipe is purchased from the market, be sure to use the heat insulation materials of the same type (with a thickness of over 9mm).

2. Deploy the pipelines

- 1) Drill a porthole on the wall, and put the hole sheath and hole cover through the wall.
 - 2) Place the connective pipe together with the indoor & outdoor connection wires. Use wrapping tape to tie them tight. Do not let air penetrate into it lest condensation and drips of moist.
 - 3) Pull the connective wrapped connective pipe from outdoor through the sheath, which gets through the wall, and lead it into the room.
3. Make a vacuum of connective pipeline.
4. After the above steps are completed, the spool of the valve of the outdoor unit should be completely open, and the refrigerant pipeline of the indoor unit and the outdoor unit should be smooth.
 5. Use a leak detector or soap water detect leak carefully to prevent leakage.
 6. Put on an adiabatic envelope (accessory) at connective pipe adapter of the indoor unit, and wrap it tight with the wrapping tape lest condensate and leakage.

6.4 Pipeline connection

1. Flare

- 1) Use a pipe cutter to cut off the pipe (See Fig.6-4)

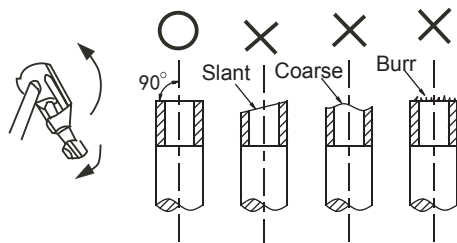

Fig.6-4

- 2) Pull the pipe into the rear flare of the connective nut. (Refer to Table: 6-2)

Table: 6-2

Outer diameter (mm)	A(mm)	
	Max.	Min.
Φ6.4	8.7	8.3
Φ9.5	12.4	12.0
Φ12.7	15.8	15.4
Φ15.9	19.0	18.6
Φ19.1	23.3	22.9

2. Tighten the nut

Align with the connective pipe, screw up the connection pipe nut manually, and use a spanner to tighten it as shown in Fig.6-5.

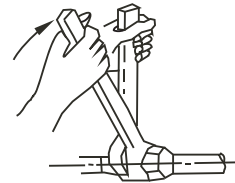

Fig.6-5



CAUTION

According to the installation conditions, too large torque will damage the flaring, and too small torque will lead to looseness and leakage. Determine the tightening torque by reference to Table: 6-3.

Table: 6-3

Pipe Size	Torgue N.m
Φ6.4	14.2~17.2 N.m (144~176 kgf.cm)
Φ9.5	32.7~39.9 N.m (333~407 kgf.cm)
Φ12.7	49.5~60.3 N.m (504~616 kgf.cm)
Φ15.9	61.8~75.4 N.m (630~770 kgf.cm)
Φ19.1	97.2~118.6 N.m (990~1210 kgf.cm)



CAUTION

- Please beware when install connective pipe, do not let any air, dust or other foreign substance invading into system.
- Pipes connection could be conducted after the indoor and outdoor unit are be fixed.
- Connective pipe must keep in dry when installation, do not let water invade in it.
- Connective copper pipe must be wrapped insulation layer (at least 9 mm thickness)

6.5 Air expels

Apply vacuum pump expels air from refrigerant charging vent of air side in outdoor unit.
It is forbidden to apply the refrigerant inside of indoor unit for vacuum air.

6.6 Open valve

Employ a 5 mm hexagon spanner to open the valve spool of indoor and outdoor unit.

6.7 Leak detection

Use soap water to check whether gas leakage exists at the adapters

6.8 Thermal insulation

To process the thermal insulation for air side and liquid side piping. Please insulated the air side and liquid side piping completely, in the reason of during operate cooling mode the ambient temperature is very low.

- 1) Thermal insulation at least 120 °C material shall be apply for air side piping.
- 2) Apply attached thermal insulation material to wrap the connective part of indoor piping tightly without gap.

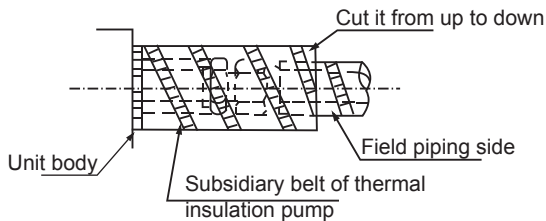

Fig.6-6

7. WIRING

7.1 Electrical wiring



CAUTION

- 1) Special power shall be applied within rated voltage range. External circuit of this air conditioner must be grounded that means power cable of outdoor unit shall be jointed with external grounding wire reliable.
- 2) Electric wiring must be done by professionals, and wiring according to the wiring label.
- 3) Fixing circuit must be wired with an a11-poledisconnection device at least 3mm switching distance of contact.
- 4) Setting the electrical leakage device according to national regulation.
- 5) Power cables and signal wires shall be arranged orderly and be wired rational without mutual interfere, and connective pipes and body of valves without mutual contact among them.
- 6) The attached connective wire is 10m, provided that the length were not long enough, you must replace it by an appropriate length connective wire in the same specification. In a normal circumstance, it is not allowed to overlapping the two wires, but welded fix and wrapped by insulation adhesive band is except.
- 7) All electric wiring is finished, you could input power as long as confirm that all wires connect are correct and fix tightly.

7.2 Power specification

The power cable specifications are as follows. In case power capacity is too low may result in over-heating of piping that would be burned out the unit (refers to Table 7-1).

7.3 Indoor and outdoor unit communication wire

- 1) The controlling wire has to use shielding line. Use other wires may produce signal disturb and cause malfunction.
- 2) Inter-connect all the shielding nets of shielding line, and at last be together connect to the metal plate grounding "⊕" (refers to Fig.7-1).
- 3) Prohibit tying up controlling wire and refrigerant pipe, power line etc. together. When the power line and the controlling wire are parallel lain, their distance should be at least 300mm, for avoiding the signal source will be disturbed.
- 4) The controlling wire can not be closed loop.
- 5) The controlling wire has polarity, and pay attention while wiring and wire correctly.
- 6) The indoor and outdoor units please use three-core shielding wire (greater than or equal to 0.75mm²), and the shielding wire has polarity, and need to be wired correctly; The indoor and outdoor unit signal wires can only be led out and connect from the outdoor main unit.

7.4 Indoor unit power supply

- 1) The indoor unit power source should not be shared with outdoor unit.
- 2) The indoor units that connect to the same outdoor unit should use the same power source, creepage protector and main switch.

7.5 Dispose of the wiring connector

Use attached heat-insulating materials to seal up the wiring connector, and if sealing failure it will cause condensation.

7.6 The wiring of the panel

Connect the swinging motor wire holder according to the Panel Installation Instruction.

7.7 Terminal board setup diagram

Wiring refers to the every indoor unit connecting diagram.

Table 7-1

Model:MDV-D Item	Power supply of indoor part				Connect wiring		Ground Line	
	Power supply	Power switch		Power cable		Signal wire of indoor and outdoor unit		
		Capacity	Safety fuse	Below 20m	Below 50m	Qty.		Wire diameter
2200W~7100W (N1)	Signal-phase 220-240V~, 1PH, 50Hz	15A	15A	2×2.5mm ²	2×6mm ²	1	Three-core shielding wire 0.75mm ²	Single-line 2.5mm ²
2200W~7100W (DN1)				2×4mm ²	2×6mm ²			Single-line 3.0mm ²

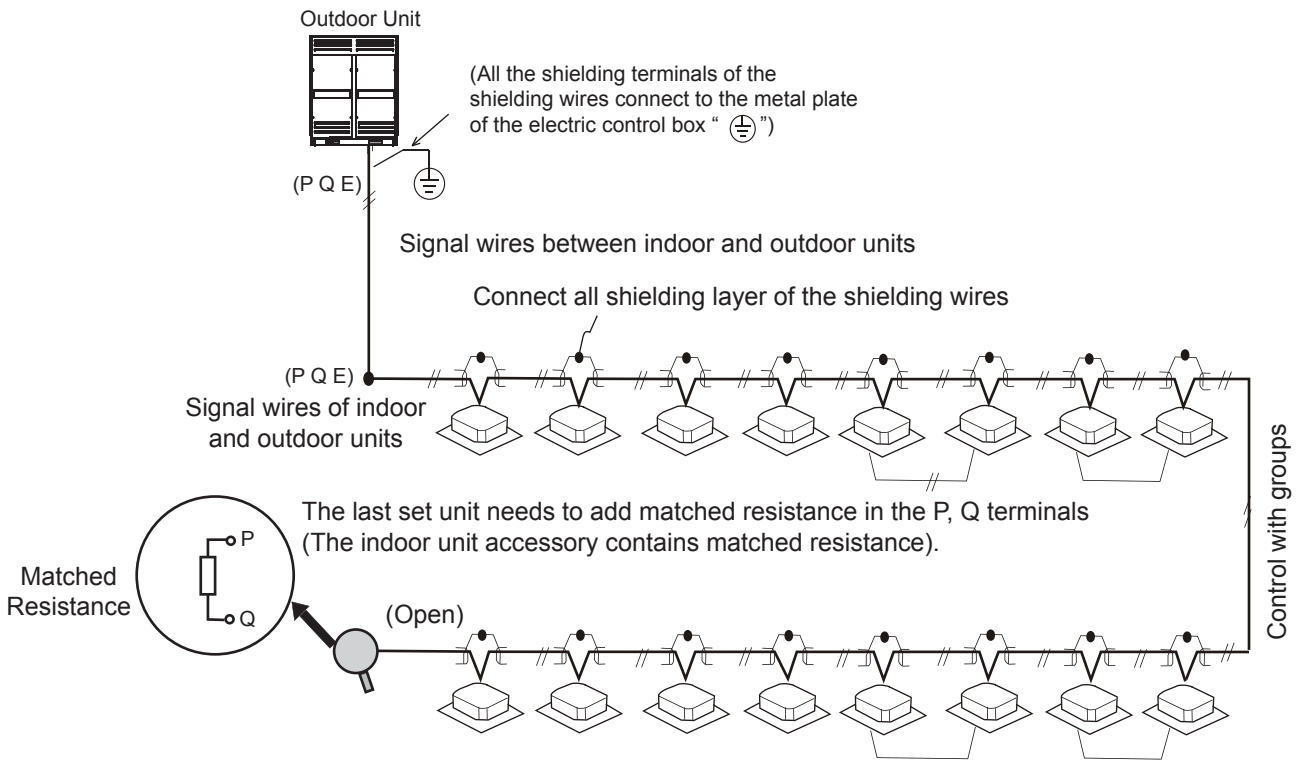

Fig.7-1

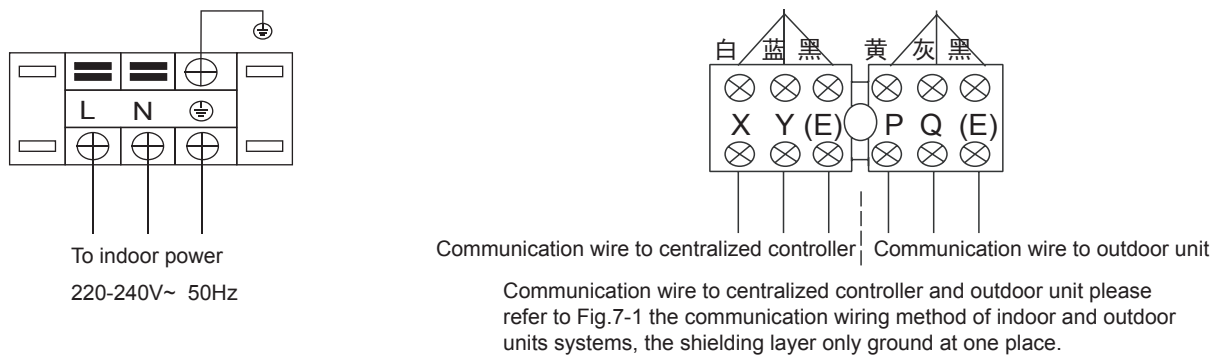

Fig.7-2

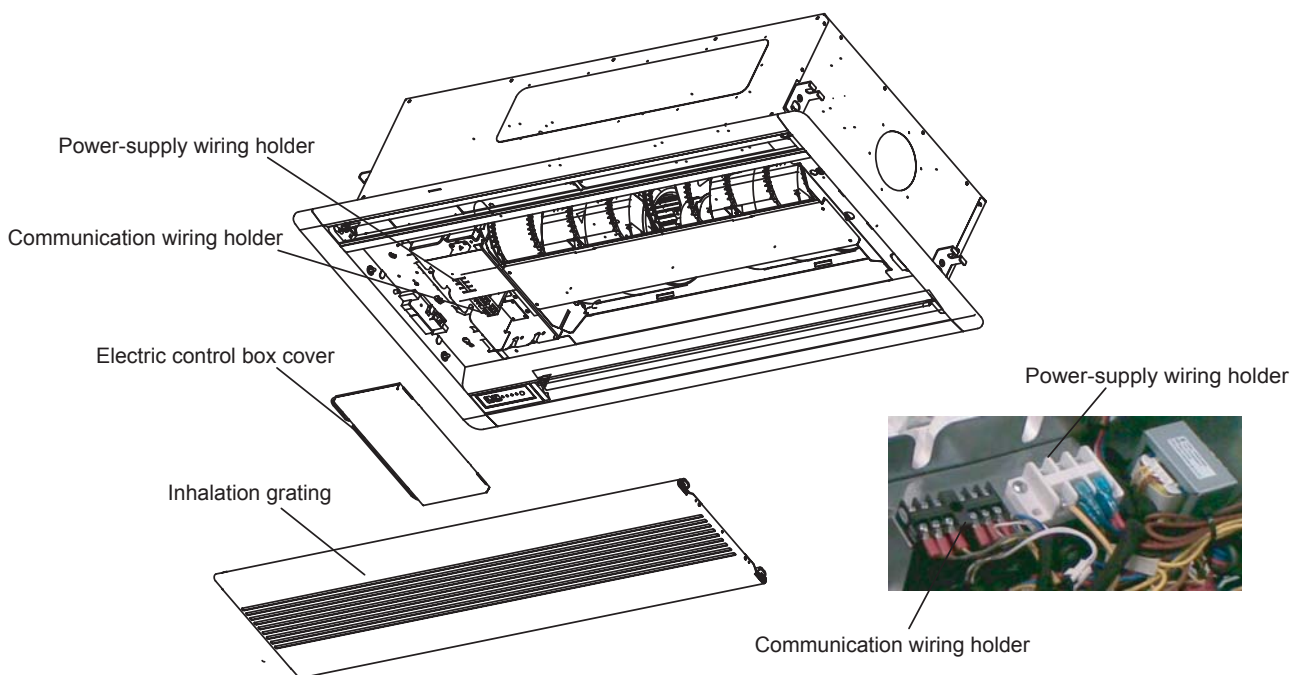
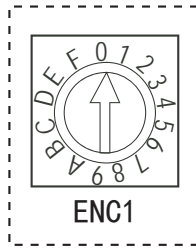

Fig.7-3

8. CONTROL OPERATION

8.1 Horsepower set



Base on different purposes to setting the switch cords on PC panel of indoor electrical control box. Once finish the setting, please cut off the main power, and then input power again, otherwise, setting function could not work.

Table.8-1

ENC1	Toggle switch	For set horsepower
Note: The horsepower has been set before leaving the factory , anyone can't modify it except the maintenance person.	Code	Capacity(Horsepower)
	0	2200W(0.8HP)
	1	2800W(1.0HP)
	2	3600W(1.2HP)
	3	4500W(1.5HP)
	4	5600W(2.0HP)
	5	7100W(2.5HP)



CAUTION

The system together have 64units(0-63),everyone has only system addresscode,if two addresses are the same in one system , the abnormal operation will occur.

Please switch off the power before setting,otherwise the unexpected error will occur.

8.2 Network address set

- Network address is set by communication of indoor and outdoor unit; the address is the same as indoor address, there is no need to set separately.
- The central control of indoor units can be done on outdoor unit, there is no need to control indoor unit separately, for details please refer to V4+ outdoor unit manual.
- For previous control of indoor units, the network can be set by connecting (X,Y,E) terminals, there is no need to set network address. The network can also be set by outer network module and main board (CN20).

8.3 Main board Code designation

SW1 definition

ON	SW1 1 2 3 4	<ul style="list-style-type: none"> ● 1 means factory test mode ● 0 means add. auto searching mode (default setting)
ON	SW1 1 2 3 4	<ul style="list-style-type: none"> ● 1 means factory test mode ● 0 means AC fan Is chosen
ON	SW1 1 2 3 4	<ul style="list-style-type: none"> ● 00 means DC fan static pressure is 0 (reserved)

ON	SW1 1 2 3 4	<ul style="list-style-type: none"> ● 01 means DC fan static pressure is 1 (reserved)
ON	SW1 1 2 3 4	<ul style="list-style-type: none"> ● 10 means DC fan static pressure is 2 (reserved)
ON	SW1 1 2 3 4	<ul style="list-style-type: none"> ● 11 means DC fan static pressure is 3 (reserved)

SW2 definition

ON	SW2 1 2 3 4	<ul style="list-style-type: none"> ● 00 means the temperature is 15 degrees when shutting down the unit for cold wind proof.
ON	SW2 1 2 3 4	<ul style="list-style-type: none"> ● 01 means the temperature is 20 degrees when shutting down the unit for cold wind proof.
ON	SW2 1 2 3 4	<ul style="list-style-type: none"> ● 10 means the temperature is 24 degrees when shutting down the unit for cold wind proof.
ON	SW2 1 2 3 4	<ul style="list-style-type: none"> ● 11 means the temperature is 26 degrees when shutting down the unit for cold wind proof.

ON	SW2 1 2 3 4	<ul style="list-style-type: none"> ● 00 means the time of stopping TERMAL fan is 4 minutes
ON	SW2 1 2 3 4	<ul style="list-style-type: none"> ● 01 means the time of stopping TERMAL fan is 8 minutes
ON	SW2 1 2 3 4	<ul style="list-style-type: none"> ● 10 means the time of stopping TERMAL fan is 12 minutes
ON	SW2 1 2 3 4	<ul style="list-style-type: none"> ● 11 means the time of stopping TERMAL fan is 16 minutes

SW5 definition

<p>ON SW5 1 2</p>	<ul style="list-style-type: none"> ● 00 means temperature compensation is 6 degrees under heating mode
<p>ON SW5 1 2</p>	<ul style="list-style-type: none"> ● 01 means temperature compensation is 2 degrees under heating mode

<p>ON SW5 1 2</p>	<ul style="list-style-type: none"> ● 10 means temperature compensation is 4 degrees under heating mode
<p>ON SW5 1 2</p>	<ul style="list-style-type: none"> ● 11 means temperature compensation is 8 degrees under heating mode

SW6 definition

<p>ON SW6 1 2 3</p>	<ul style="list-style-type: none"> ● 1 means old display panel ● 0 means new display panel
<p>ON SW6 1 2 3</p>	<ul style="list-style-type: none"> ● 1 means auto wind under auto mode ● 0 means auto wind under non auto mode
<p>ON SW6 1 2 3</p>	reserved

J1,J2 definition

<p>J1</p>	J1 no Jumpers means power off memory function
<p>J1</p>	J1 Jumpers means no power off memory function
<p>J2</p>	reserved

SW7 definition

<p>ON SW7 1 2</p>	Standard configure
<p>ON SW7 1 2</p>	Last one in the network

O/1 definition

<p>ON</p>	Means 0
<p>ON</p>	Means 1

8.4 Fault code and indicating meaning

Fault Code	Indicating Meaning
First power on, if no address	The timing and operating lamps will be flashed or display FE at the same time
M_Home not matching fault	4 Lamps will be flashed or display H0 at the same time
Mode conflict fault	The defrosting lamp will be flashed or display E0
Indoor and outdoor units communication fault	The timing lamp will be flashed or display E1
Indoor unit temperature sensor (T1) fault	The operating lamp will be flashed or display E2
Swinging motor fault	Display E8
Temperature sensor (T2) fault	The operating lamp will be flashed or display E3
Temperature sensor (T2B) fault	The operating lamp will be flashed or display E4
EEPROM fault	The defrosting lamp will be flashed slowly or display E7
Outdoor unit fault	The alarm lamp will be flashed slowly or display Ed
Water level alarm fault	The alarm lamp will be flashed or display EE
_____	_____

9. TEST OPERATION

- The test operation must be carried out after the entire installation has been completed.
- Please confirm the following points before the test operation:
 - The indoor unit and outdoor unit are installed properly.
 - Tubing and wiring are correctly completed.
 - The refrigerant pipe system is leakage-checked.
 - The drainage is unimpeded.
 - The heating insulation works well.
 - The ground wiring is connected correctly.
 - The length of the tubing and the added stow capacity of the refrigerant have been recorded.
 - The power voltage fits the rated voltage of the air conditioner.
 - There is no obstacle at the outlet and inlet of the outdoor and indoor and indoor units.
 - The gas-side and liquid-side stop valves are both opened.
 - The air conditioner is pre-heated by turning on the power.
- According to the user's requirement, install the remote controller frame where the remote controller's signal can reach the indoor unit smoothly.
- Test operation
Set the air conditioner under the mode of "COOLING" with the remote controller, and check the following points per the "Owner's Manual". If there is any malfunction, please resolve it through chapter "Troubles And Causes" in the "Owner's Manual".
 - The indoor unit
 - Whether the switch on the remote controller works well.
 - Whether the buttons on the remote controller works well.
 - Whether the air flow louver moves normally.
 - Whether the room temperature is adjusted well.
 - Whether the indicator lights normally.
 - Whether the temporary buttons works well.
 - Whether the drainage is normal.
 - Whether there is vibration or abnormal noise during operation.
 - Whether the air conditioner heats well in the case of the HEATING/COOLING type.
 - The outdoor unit
 - Whether there is vibration or abnormal noise during operation.
 - Whether the generated wind, noise, or condensed water by the air conditioner have influenced your neighborhood.
 - Whether any of the refrigerant is leaked.



A protection feature prevents the air conditioner from being activated for approximately 3 minutes when it is restarted immediately after shut off.
