



9800 Martel Road

Lenoir City, TN 37772

[www.ps-engineering.com](http://www.ps-engineering.com)

# PMA7000H



Document P/N 200-780-0429

Rev. 5 February 2015

Audio Selector Panel with Marker Beacon Receiver

High-fidelity Stereo Intercom

## System Installation and Operation Manual

FAA-Approved TSO C50c, C35d

JAA-Approved JTSO C50c, 2C35d

***Patented under one or more of the following; No. 5,903,227; 6,160,496 and 6,493,450***

**In certified aircraft, warranty is not valid unless this product is installed by an Authorized PS Engineering dealer.**

**PS Engineering, Inc. 2015©**

**Copyright Notice**

Any reproduction or retransmittal of this publication, or any portion thereof, without the expressed written permission of PS Engineering, Inc. is strictly prohibited. For further information contact the Publications Manager at PS Engineering, Inc., 9800 Martel Road, Lenoir City, TN 37772. Phone (865) 988-9800, email [avionics@ps-engineering.com](mailto:avionics@ps-engineering.com).

Table of Contents

<b>SECTION I GENERAL INFORMATION .....</b>	<b>1-1</b>
<b>1.1 INTRODUCTION .....</b>	<b>1-1</b>
<b>1.2 SCOPE.....</b>	<b>1-1</b>
<b>1.3 EQUIPMENT DESCRIPTION .....</b>	<b>1-1</b>
<b>1.4 APPROVAL BASIS .....</b>	<b>1-2</b>
<b>1.5 SPECIFICATIONS .....</b>	<b>1-2</b>
<b>1.6 EQUIPMENT SUPPLIED .....</b>	<b>1-3</b>
<b>1.7 EQUIPMENT REQUIRED BUT NOT SUPPLIED.....</b>	<b>1-4</b>
<b>1.8 LICENSE REQUIREMENTS .....</b>	<b>1-4</b>
<b>SECTION II - INSTALLATION .....</b>	<b>2-1</b>
<b>2.1 GENERAL INFORMATION .....</b>	<b>2-1</b>
2.1.1 SCOPE .....	2-1
2.1.2 CERTIFICATION REQUIREMENTS .....	2-1
<b>2.2 UNPACKING AND PRELIMINARY INSPECTION .....</b>	<b>2-1</b>
<b>2.3 EQUIPMENT INSTALLATION PROCEDURES .....</b>	<b>2-1</b>
2.3.1 COOLING REQUIREMENTS .....	2-1
2.3.2 MOUNTING REQUIREMENTS.....	2-1
2.3.3 AUDIO PANEL MOUNTING RACK INSTALLATION .....	2-1
2.3.4 AUDIO PANEL TRAY AND CONNECTOR ASSEMBLY .....	2-2
<b>2.4 CABLE HARNESS WIRING.....</b>	<b>2-2</b>
2.4.1 NOISE .....	2-3
2.4.2 POWER.....	2-3
2.4.3 AUDIO PANEL INTERFACE .....	2-3
2.4.4 COM 3 DUPLEX (TEL) FUNCTION FOR CELL PHONES.....	2-4
2.4.5 TRANSMIT INTERLOCK .....	2-4
2.4.6 "SWAP" MODE.....	2-4
2.4.7 BACKLIGHTING .....	2-5
2.4.8 UNSWITCHED INPUTS .....	2-5
2.4.9 PA MUTE (J1, PIN 18) .....	2-5
2.4.10 PUBLIC ADDRESS FUNCTION (J2, PIN 18) .....	2-5
2.4.11 CONTROL OUTPUT (J2, PIN A) .....	2-5
2.4.12 COCKPIT VOICE RECORDER OUTPUT .....	2-5
2.4.13 INTERCOM WIRING .....	2-5
<b>2.5 MARKER BEACON INSTALLATION .....</b>	<b>2-7</b>
2.5.1 MARKER ANTENNA INSTALLATION .....	2-7
2.5.2 EXTERNAL MARKER LIGHTS.....	2-7
2.5.3 MIDDLE MARKER SENSE.....	2-7
<b>2.6 ADJUSTMENTS.....</b>	<b>2-7</b>
<b>2.7 COMMUNICATIONS ANTENNA INSTALLATION NOTES.....</b>	<b>2-8</b>
2.7.1 HOOK SWITCHES .....	2-8
<b>2.8 PMA7000H PIN ASSIGNMENTS .....</b>	<b>2-8</b>
<b>2.9 POST INSTALLATION CHECKOUT .....</b>	<b>2-10</b>
<b>2.10 UNIT INSTALLATION .....</b>	<b>2-10</b>
2.10.1 REQUIRED TEST EQUIPMENT .....	2-10
2.10.2 OPERATIONAL CHECKOUT .....	2-10
2.10.3 RECEIVER SENSITIVITY .....	2-11
<b>2.11 CELLULAR INTERFACE CHECKOUT .....</b>	<b>2-11</b>
<b>2.12 FINAL INSPECTION.....</b>	<b>2-12</b>

<b>SECTION III OPERATION .....</b>	<b>3-1</b>
<b>3.1 SCOPE.....</b>	<b>3-1</b>
<b>3.2 POWER SWITCH (EMG-FAIL SAFE OPERATION).....</b>	<b>3-1</b>
<b>3.3 MICROPHONE (XMT) SELECTION (ALL MODELS) .....</b>	<b>3-1</b>
3.3.1 SWAP MODE (SWITCH FROM COM 1 TO COM 2 REMOTELY).....	3-2
<b>3.4 AUDIO SELECTOR (ALL MODELS) .....</b>	<b>3-2</b>
3.4.1 SPEAKER AMPLIFIER .....	3-2
3.4.2 KEY "CLICK".....	<b>ERROR! BOOKMARK NOT DEFINED.</b>
<b>3.5 SPLIT MODE.....</b>	<b>3-2</b>
3.5.1 SPLIT MODE ICS .....	3-3
<b>3.6 INTERCOM OPERATION .....</b>	<b>3-3</b>
3.6.1 INTELLIVox® VOX-SQUELCH .....	3-3
3.6.2 INTERCOM VOLUME CONTROL .....	3-4
3.6.3 INTERCOM MODES .....	3-4
<b>3.7 PUSH-TO-TALK INTERCOM MODE.....</b>	<b>3-6</b>
<b>3.8 TELEPHONE MODE .....</b>	<b>3-6</b>
<b>3.9 MARKER BEACON OPERATION .....</b>	<b>3-6</b>
<b>SECTION IV- WARRANTY AND SERVICE .....</b>	<b>4-1</b>
<b>4.1 WARRANTY .....</b>	<b>4-1</b>
<b>4.2 FACTORY SERVICE .....</b>	<b>4-1</b>
<b>APPENDIX A – PMA7000H INSTALLATION DRAWING .....</b>	<b>A</b>
<b>APPENDIX B BOTTOM CONNECTOR INTERCONNECT .....</b>	<b>B</b>
<b>APPENDIX C TOP CONNECTOR INTERCONNECT.....</b>	<b>C</b>
<b>APPENDIX D- INSTRUCTIONS FOR FAA FORM 337 AND CONTINUING AIRWORTHINESS.....</b>	<b>D</b>
8.1 INSTRUCTIONS FOR FAA FORM 337, AUDIO PANELS .....	D
8.2 INSTRUCTIONS FOR CONTINUING AIRWORTHINESS, AUDIO SYSTEM .....	D
<b>APPENDIX E RTCA DO160C (EUROCAE ED-14) ENVIRONMENTAL QUALIFICATION FORM .....</b>	<b>E</b>

*Revision History*

<b>Rev</b>	<b>By</b>	<b>Date</b>	<b>Change</b>
New	GP	8/3/2006	New Release
1	GP	2/6/2007	Updated Graphics
2	GP	1/28/2009	Updated for 10 place, ALT ICS mode.
3	GP	12/20/2010	Added enhanced CVR Version, corrected §2.4.8 Unswitched input muting
4	GP	12/21/2012	Removed §2.4.11 for AUX output use with off hook
5	GP	2/18/2015	Changed number of pins supplied

## Section I GENERAL INFORMATION

### 1.1 INTRODUCTION

The PMA7000H represents the next step in cockpit audio control and intercommunications utility. Using proprietary *IntelliVox*® design, this unit eliminates the requirements for intercom squelch adjustments. The unit is designed for outstanding ergonomics and visually defined mode annunciation and selection.

Before installing and/or using this product, please read this manual completely. This will ensure that you will take full advantage of all the advanced features in the PMA7000H.

### 1.2 SCOPE

This manual provides detailed installation and operation instructions for the PS Engineering PMA7000H- of Audio Selector Panel/Intercom Systems. This includes the following units:

<u>Model</u>	<u>Description</u>	<u>Part Number</u>
PMA7000H	Stereo Audio Selector Panel with Marker Beacon	7000H
PMA7000H	Same as PMA7000H with enhanced Cockpit Voice Recorder output	7000H-CVR

### 1.3 EQUIPMENT DESCRIPTION

The PMA7000H- is an audio isolation amplifier / audio selector that contains a 10-place (9-places in units with serial number starting with "A" Serial Number "B" and above have 10-places) automatic voice activated (VOX) intercom system. It can switch up to three transceivers (Com 1, Com 2 and Com 3) and six receivers (Nav 1, Nav 2, ADF, DME, MKR and AUX).

A duplex COM 3 mode (selectable at installation) allows the PMA7000H to act as an audio interface between aircraft headphone and microphones and specific aircraft approved (FAA/FCC) cellular telephone equipment.

**Warning:** Use of non-aviation approved cellular telephone equipment in flight may be prohibited by regulation.

PS Engineering is not responsible for unauthorized airborne use of cellular telephones.  
For airborne use, the PMA7000H must be interfaced with an approved system.

There are four unswitched inputs, available for traffic or EGPWS, autopilot disconnect, and/or radar altimeter warning.

Push buttons select the receiver audio source provided to the headphones. A SPR button allows the user to listen to the receiver(s) selected on the cabin speaker. Except for the unswitched inputs, all speaker audio is muted during transmit.

Push button switches select one of the communication transceivers for the pilot and copilot position, and allows radio transmission. In "Split Mode" the PMA7000H has the ability to allow the pilot and copilot to operate different transceivers independently. The Com 3/TEL mode (selected at installation) allows the pilot to use the audio panel for duplex operation, such as with aviation-specific cellular telephones. External switches permit telephone operation for the copilot and passengers.

A fail-safe mode connects the pilot headphone and microphone to COM 1 and unswitched input #1 if power is removed for any reason, or if the power switch is placed in the Off (Fail-safe) position.

A 9-station voice activated (VOX) intercom is included in the PMA7000H. This system has PS Engineering's exclusive *IntelliVox*® circuitry that eliminates manual adjustments. The system contains nine separate VOX mic circuits, and only opens the microphone channel in use.

The intercom system incorporates pilot isolate and crew modes, two independent stereo music inputs with "Soft Mute," and flashing LED indicators for transmit indications. Intercom control is through two front panel- mounted volume knobs and 3-position mode switch. The concentric volume controls the intercom

level for the pilot and copilot, while the outer knob controls the passenger intercom volume. Intercom squelch is automatic.

A 3-light Marker Beacon receiver is integrated in the PMA7000H. This provides the necessary Marker Beacon lights and audio indications necessary for an Instrument Landing System (ILS) approach.

#### **1.4 APPROVAL BASIS -**

##### **TSO Approval.**

The PMA7000H Audio Selector Panels are FAA approved under TSO C50c (Audio Amplifiers) and TSO C35d (Marker Beacon Receivers). In addition, they are approved by the Joint Airworthiness Authorities under JTSO C50C and JAR-TSO 2C35d.

All systems comply with relevant portions of EUROCAE RTCA MPS WG No. 7/70, DO-143 and (*Marker Beacon Receivers*), ED-14C/DO-160C (*Environmental Conditions and Test Procedures for Airborne Equipment*), ED12B/DO-178B (*Software Considerations for Airborne Equipment*) and ED- 18/DO-214 (*Audio Systems Characteristics and Minimum Operational Performance Standards for Aircraft Audio Systems*).

Operation is subject to the following conditions:

This device may not cause harmful interference.

This device must accept any interference received, including interference that may cause undesired operation.

#### **1.5 SPECIFICATIONS**

<b>TSO COMPLIANCE</b>	
<i>Marker Beacon:</i>	C35d, Class A
<i>Audio Selector/Intercom:</i>	C50c, Class A
APPLICABLE DOCUMENTS:	RTCA/DO-214 RTCA/DO-143 RTCA/DO-160C RTCA/DO-178B
<b>ENVIRONMENTAL Qualifications:</b>	A1D1/CA(MN)XXXXXXBBBBTBKXX
<i>Operating Temperature Range:</i>	-15° C to 55°C
<i>Altitude:</i>	Up to 50,000 feet in a non-pressurized area
DIMENSIONS:	Height: 1.3 in. (3.3 cm) Width: 6.25 in. (16.9 cm) Depth: 6.8 in. (17.3 cm)
WEIGHT (With Rack & Connectors):	1.5 lb. (0.54 kg)
<b>POWER REQUIREMENTS (Including Internal Lighting):</b>	
<i>Voltage:</i>	11 to 33 VDC
<i>Maximum Current:</i>	2.5 Amp (Externally protected by a 3A pull-type breaker)

**PS Engineering**  
PMA7000H Series Audio Selector Panel and Intercom System  
Installation and Operator's Manual

<b>Audio Selector Specifications</b>	
<i>Audio selector panel input impedance:</i>	510 Ω
<i>Input Isolation:</i>	-60 dB (min.)
<i>Speaker Muting:</i>	-60 dB (min.)
<i>Speaker Output (into 4 Ω) with no clipping</i>	
14 VDC:	3 Watts (min.)
28 VDC:	10 Watts (min.)
<i>Receiver Inputs:</i>	9 (Com 1, Com 2, Com 3, Nav 1, Nav 2, ADF, DME, MKR, AUX)
<i>Unswitched Inputs:</i>	4
<i>Transmitter Selections:</i>	5 (Com 1, Com 2, Com 3 Com1/2, Com1/3)
<i>Speaker Impedance:</i>	4 Ω
<i>Headphone Impedance:</i>	150 – 1000 Ω
<i>Headphone Output:</i>	38 mW each headset, no clipping <1% THD
<i>Microphone Impedance:</i>	150 - 600 Ω

<b>Intercom Specifications</b>	
<i>Intercom Positions:</i>	10 places (with individual <i>IntelliVox</i> ® circuits)
<i>Music Inputs:</i>	2, (Independent, Stereo)
<i>Music Muting:</i>	>-30 dB "Soft Mute" when Com or intercom active.
<i>Distortion:</i>	<1% THD @ 38 mW into 150Ω
<i>Mic Freq. Response, 3 dB:</i>	300 Hz - 6000 Hz
<i>Music Freq. Response, 3 dB:</i>	20 Hz - 18kHz
<b>MARKER BEACON RECEIVER: (if equipped)</b>	
<i>Frequency:</i>	75 MHz Crystal Controlled
<i>Sensitivity:</i>	Capable of: (preset at factory for field application)
Low:	1000 μVolts (Hard) (360 to 570 μV soft)
High:	200 μVolts (Hard) (130 to 200 μV soft)
<i>Selectivity:</i>	-6 dB at ±10 kHz -40 dB at ±120 kHz
<i>External Lamp Output:</i>	7.5 (±4 VDC unloaded, at maximum brightness) VDC positive when active, max. current 125 mA
<i>MM Sense:</i>	Active high (4.5 ± 1.0VDC)

## 1.6 EQUIPMENT SUPPLIED

1 ea. of the following units:

Model	Description	Part Number
PMA7000H	PMA7000H Audio Panel with Marker Beacon and Stereo intercom.	7000H
PMA7000H	Same as PMA7000H with enhanced Cockpit Voice Recorder output	7000H-CVR

PMA7000H Installation Kit: 250-007-0002

Description	Quantity	Part Number
PMA7000 installation rack assembly	1	120-430-0420
Top Molex Connector Shell w/key, 44 pin, key 4/5	1	120-425-4402
Bottom Molex Connector Shell w/key, 44 pin, key 7/8	1	120-425-4400
Gold Plated Crimp Pins	78	425-001-0002
4 40 X 7/16 screw w/nylon patch	4	475-440-0007
Grounding bar	1	430-007-0001
6-32 X 3/4 pan head Phillips screw	2	475-632-0038
6-32 Nut Flat	2	475-632-0003
6-32 Lock Nut	2	475-632-0004
Cable Clamp	1	625-001-0002

**PS Engineering**  
PMA7000H Series Audio Selector Panel and Intercom System  
Installation and Operator's Manual

Description	Quantity	Part Number
#6-32 x 1/2" Flat head Phillips screw	6	475-632-0012
#6-32 Clip Nut	6	475-630-0002
Parts identification sheet	1	002-250-7028

**1.7 EQUIPMENT REQUIRED BUT NOT SUPPLIED**

- a) Circuit Breaker: 1 ea; 3 amp PULL TYPE REQUIRED for PMA7000H
- b) Speaker, 4  $\Omega$
- c) Headphone Jacks (Stereo, as Required)
- d) Microphone Jacks (as Required)
- e) Headphones, 150  $\Omega$  (Stereo), up to 9, as required
- f) Microphones, up to 9, as required
- g) Marker Antenna (75 MHz, VSWR <1:1.5, and appropriate for the airspeed)
- h) Interconnect Wiring

**1.8 LICENSE REQUIREMENTS**

None

## Section II - Installation

### 2.1 GENERAL INFORMATION

#### 2.1.1 SCOPE

This section provides detailed installation and interconnection instructions for the PS Engineering PMA7000H Audio Selector Panel/Intercom/ with internal Marker Beacon.

Please read this manual carefully before beginning any installation to prevent damage and post-installation problems. Installation of this equipment requires special tools and knowledge.

#### 2.1.2 Certification Requirements

#### NOTE

The PMA7000H requires specialized knowledge and tools for an effective installation. An appropriately rated Certified Aircraft Repair Station or Aircraft Manufacturer **must** install this equipment in accordance with applicable regulations. PS Engineering, Incorporated warranty is not valid unless the equipment is installed by an authorized PS Engineering, Incorporated dealer.

Failure to follow any of the installation instructions, or installation by a non-certified individual or agency will void the warranty, and may result in an **unairworthy** installation.

### 2.2 Unpacking and Preliminary Inspection

Use care when unpacking the equipment. Inspect the units and parts supplied for visible signs of shipping damage. Examine the unit for loose or broken buttons, bent knobs, etc. Verify the correct quantity of components supplied with the list in Section 1.6 (B). If any claim is to be made, save the shipping material and contact the freight carrier. Do NOT return units damaged in shipping to PS Engineering. If the unit or accessories show any sign of external shipping damage, contact PS Engineering to arrange for a replacement. Under no circumstances attempt to install a damaged unit in an aircraft. Equipment returned to PS Engineering for any other reason should be shipped in the original PS Engineering packaging, or other UPS approved packaging.

### 2.3 Equipment Installation Procedures

#### 2.3.1 Cooling Requirements

Forced air-cooling of the PMA7000H is not required. However, the units should be kept away from heat producing sources (i.e. defrost or heater ducts, dropping resistors, heat producing avionics) without adequate cooling air provided.

#### 2.3.2 Mounting Requirements

The PMA7000H must be rigidly mounted to the instrument panel of the aircraft structure and within view and reach of the pilot position(s). Installation must comply with FAA Advisory Circular AC 43.13-2A. The unit may be mounted in any area where adequate clearance for the unit and associated wiring bundle exist.

Avoid installing the unit close to high current devices or systems with high-voltage pulse type outputs, such as DME or transponders. Avoid running the interconnecting bundles near any high current wires.

#### 2.3.3 Audio Panel Mounting Rack Installation

Remove the unit from the mounting tray by unscrewing the 3/32" hex-head screw that is in the center of the unit. Use caution to avoid hitting the photo-detector lens. Carefully slide the unit free of the tray. Set the unit aside in a safe location until needed. Install the tray using six clip nuts (475-630-0002), and six FHP 6-32 x 1/2" screws (475-632-0012). The audio selector panel must be supported at front and rear of the mounting tray.



### 2.3.4 Audio Panel Tray and Connector Assembly

The unit connectors mate directly with the circuit boards in the PMA7000H. The connectors are a Molex crimp-type, and require the use of a Molex hand crimp tool, EDP P/N 11-01-0203, CR6115B (or equiv.). The connectors are mounted to the unit tray with #4-40 screws (475-440-0007), from the inside of the tray. Ensure that proper strain relief and chafing precautions are made during wiring and installation, using the cable clamp (625-001-0002). Secure the ground bar (430-007-0001), if desired using, #6-32 nuts (475-632-0003) and #6-32 lock nuts (475-632-0004).

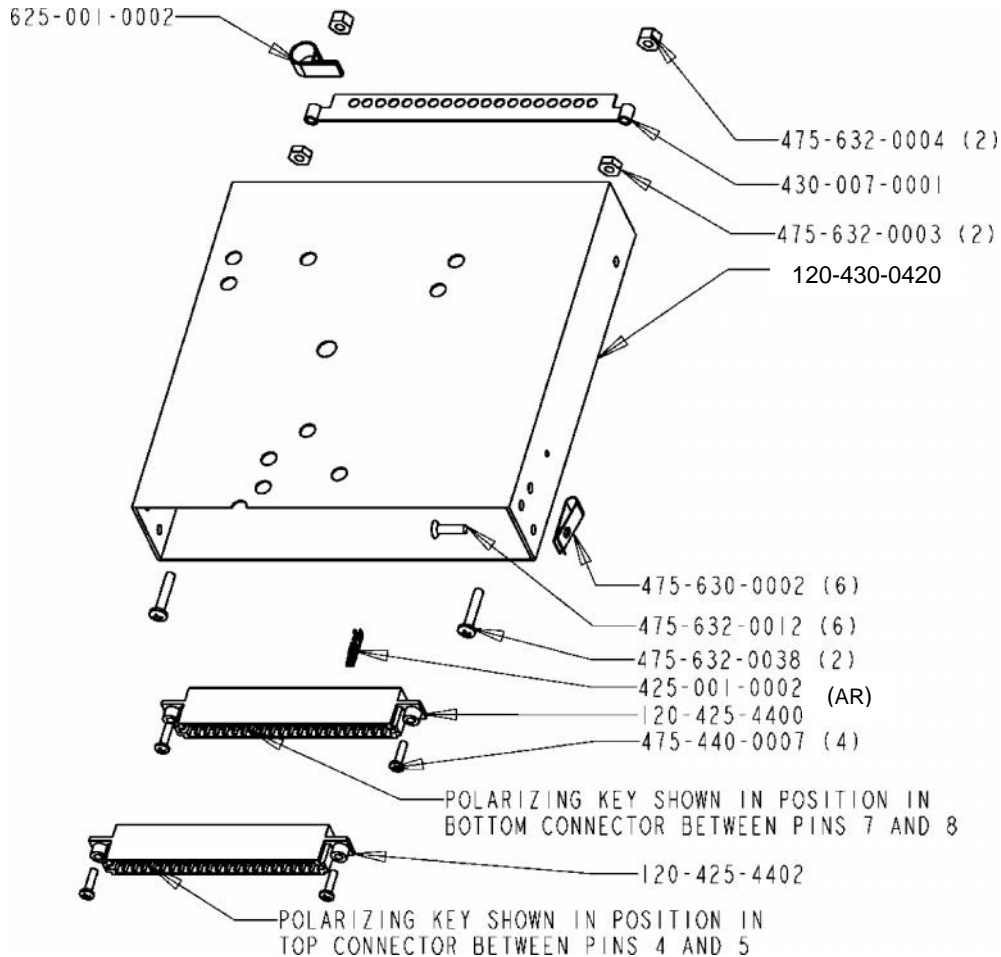

**Figure 2-1 Audio Panel Tray Assembly Drawing**

### 2.4 Cable Harness Wiring

Referring to the appropriate Appendix, assemble a wiring harness as required for the installation. All wires must be MIL-SPEC in accordance with current regulations. Two- and three-conductor shielded wire must be used where indicated, and be MIL-C-27500 or equivalent specification. Proper stripping, shielding and soldering technique must be used at all times. It is imperative that correct wire be used.

Refer to FAA Advisory Circular 43.13-2A for more information. Failure to use correct techniques may result in improper operation, electrical noise or unit failure. Damage caused by improper installation will void the PS Engineering warranty.

NOTE: PS Engineering can make a custom wiring harness for the intercom. Call 1-800-ICS-AERO or see [www.ps-engineering.com](http://www.ps-engineering.com) for details.

### 2.4.1 Noise

Due to the variety and the high power of radio equipment often found in today's general aviation aircraft, there is a potential for both radiated and conducted noise interference.

The PMA7000H power supply is specifically designed to reduce conducted electrical noise on the aircraft power bus by at least 50dB. Although this is a large amount of attenuation, it may not eliminate all noise, particularly if the amplitude of noise is very high. There must be at least 13.8 VDC present at the bottom connector, pin 20, of the PMA7000H for the power supply to work in its designed regulation. Otherwise, it cannot adequately attenuate power line noise. Shielding can reduce or prevent radiated noise (i.e., beacon, electric gyros, switching power supplies, etc.) However, installation combinations can occur where interference is possible. The PMA7000H was designed in a RFI hardened chassis and has internal Electromagnetic Interference (EMI) filters on all inputs and outputs.

Ground loop noise occurs when there are two or more ground paths for the same signal (i.e., airframe and ground return wire). Large power loads such as strobes, inverters, etc., can inject noise signals onto the airframe that are detected by the audio system. Follow the wiring diagram very carefully to help ensure a minimum of ground loop potential. Use only Mil Spec shielded wires (MIL-C-275000, or better). Under no circumstances combine a microphone and headphone wiring into the same shielded bundle. Always use a 2- or 3-conductor, shield wire as shown on the installation wiring diagram.

Radiated signals can be a factor when low level microphone signals are "bundled" with current carrying power wires. Keep these cables physically separated. It is very important that you use insulated washers to isolate the ground return path from the airframe to **all** headphone and microphone jacks.

Adding a high-performance audio control system, particularly in conjunction with high-performance active noise canceling headsets, cannot improve on older avionics that were designed for cabin-speaker use. PS Engineering makes no claim that the audio panel will provide a noise-free audio quality under all installation conditions, particularly with older avionics.

### 2.4.2 Power

The PMA7000H are compatible with both 14 and 28 Volt DC systems. A two (2) Amp circuit breaker is required for 14 VDC installations, and a three (3) Amp breaker for 28 VDC aircraft. Power and ground wires should be a twisted #18 AWG pair. Connect airframe power ground to J1 (bottom connector) Pin Z only. No dropping resistors are required.

### 2.4.3 Audio Panel interface

The PMA7000H is designed to interface with standard aircraft avionics, and presents a 500Ω receiver impedance. For best results, a twisted-shielded cable is recommended from the avionics audio source to the audio panel, with the shield grounded at the audio panel end.

Some avionics do not provide a separate audio low, and may introduce additional electrical noise into the system. For best results, connect the audio low from the audio panel to the radio ground, using one conductor of the twisted-shielded cable.

#### 2.4.3.1 Fail Safe Audio

When the audio panel is off, or power is removed, the pilot's right headphone will have the COM 1 audio, and the Unswitched Audio #1 (J1-17). It is imperative that Pin 3, J1 (bottom connector) be connected to pilot's headphone tip contact.

#### 2.4.3.2 Headphone Audio Output

The PMA7000H supports seven passengers, plus 2 crew. The passengers' headphone outputs are provided on two amplifier outputs in J2 (top connector); passengers 1, 3, 5 and 7 are connected to 12 (left) 11, (right) WRT N. Passengers 2, 4 and 6 should be connected to 19 (left) 17, (right) also WRT N.

### 2.4.3.3 Speaker Load

The PMA7000H contains a speaker amplifier. Some units with internal speaker amplifiers, such as the King Radio KX170, require a resistive load to prevent damage if their speaker amplifier is not used. Connect the speaker output from the unit to the load input on the PMA7000H (J1, pins 19 and L, 16 and M.) The speaker load is 16  $\Omega$ , 3W.

### 2.4.4 Com 3 Duplex (TEL) Function for Cell Phones

As installed in the standard configuration, the PMA7000H Com 3 function operates conventionally. Pushing the Com 3 XMT button places the receive audio from Com 3 in the headset and applies the pilot or copilot microphone to the Com 3 when the appropriate PTT is activated.

If J2, Pin J is connected to aircraft ground, the PMA7000H is forced into Com 3-Duplex mode. Copilot and passenger audio as selected by hook switches are provided to the COM 3 output, the PTT for Com 3 is inactive, and audio from Com 3 is presented to the headset. This allows a telephone-like audio interface.

In this mode, the COM 3 input and output is compatible with many cellular telephones utilizing the hands-free headset interface. A 1/8" jack can be installed on the aircraft panel, which is interfaced with the PMA7000H as shown below. To connect the cellular telephone to the jack wired in to COM 3, a patch cord is required. This patch cord is available from PS Engineering under P/N 425-006-2535 (1/8" to 3/32").

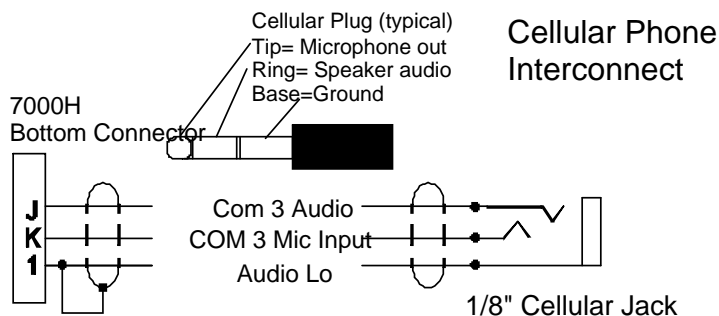

**For Duplex (cell phone) operation  
Pin J of top connector MUST BE GROUNDED  
This is a typical interconnect  
PS Engineering does not guarantee  
compatibility in all cases.**

Figure 2 -2 Cellular telephone interface

**Unauthorized use of unapproved cellular telephone devices in flight is subject to FCC enforcement action, which may include a \$10,000 fine per incident. PS Engineering, Inc. does not endorse using unapproved cellular telephone equipment in flight, and takes no responsibility for the user's action.**  
**FCC Regulation 47 CFR § 22.925 Prohibition on airborne operation of cellular telephones.**  
**Cellular telephones installed in or carried aboard airplanes, balloons or any other type of aircraft must not be operated while such aircraft are airborne (not touching the ground). When any aircraft leaves the ground, all cellular telephones on board that aircraft must be turned off.**

### 2.4.5 Transmit Interlock

Some communications transceivers use a transmit-interlock system. To fully utilize the Split Mode feature, this function must be disabled. Consult that manufacturer's installation manual.

### 2.4.6 "Swap" Mode

When a momentary, normally open, push-button switch is connected between pin 10 on the top connector and aircraft ground, the user can switch between Com 1 and 2 by depressing this switch without having to turn the mic selector switch. This yoke-mounted switch eliminates the need to remove your hands from the yoke to change transceivers. The transfer of TX indication from Com 1 to Com 2 shows that the swap has been initiated, there is no dedicated swap indicator.

### **2.4.7 Backlighting**

The PMA7000H has an automatic dimming of the pushbutton annunciator LEDs and marker lamps controlled by a photocell. Control of the unit backlighting is through the aircraft avionics dimmer. Connect the dimmer control line to J1 pin D for 14-volt systems, and to J1 pin F for 28-volt systems. Pin E is light ground.

If an external dimmer control is **not** used, a constant low-level back light illumination can be established for nighttime viewing. Pin D or F (depending on system voltage) must be tied to power (J1, pin 20) for the back lighting system to work. The photocell mounted in the unit face will automatically adjust the intensity of the push-button annunciator LEDs.

### **2.4.8 Unswitched Inputs**

J1, pins T, 17, U and X are unswitched, unmuted inputs. These inputs are presented to the pilot and copilot regardless of the audio configuration, and will mute the entertainment inputs unless the PMA7000H has the SoftMute® inhibited with the ICS button (see §3.6.3.3). These 510 inputs can be used for altimeter DH audio, GPS waypoint audio, autopilot disconnect tones, or any other critical audio signal. This input is not related to the cellular telephone interface. NOTE: These inputs are fixed (1:1), and any audio level adjustments must be made at the input source.

### **2.4.9 PA Mute (J1, Pin 18)**

Pin 18 of J1 is a TTL logic output that is pulled low during PTT operation. This serves as an input to external public address system to prevent feedback during transmissions.

### **2.4.10 Public Address Function (J2, Pin 18)**

By connecting the top connector (J2), Pin 18 to ground, the pilot's microphone audio is placed on the cabin speaker output. When the pilot's PTT is activated, his voice is heard over the speaker. The copilot can continue to use the selected com.

We recommend installing a toggle switch to connect the cabin speaker output (pin W, bottom connector) to a rear or public address speaker instead of the cockpit speaker close to the pilot. This will prevent feedback.

### **2.4.11 Control Output (J2, Pin A)**

Pin A of the top connector is pulled to ground whenever the AUX button is depressed. This serves as a control line for external devices, such as an entertainment system that the pilot wishes to control.

This could be used in conjunction with a PA to control J2, Pin 18, as well as an external relay to change to the cabin speaker from the cockpit.

This pin can also be used to control passenger Karaoke Mode, by connecting to pin V of the J2.

### **2.4.12 Cockpit Voice Recorder Output**

Top connector (J2) Pin 20 is the pilot CVR output, and Pin 21 is the copilot CVR output (WRT Pin 22). These contain the audio from selected radio and crew microphones, regardless of the intercom VOX or volume level. In the enhanced version, the audio contains the selected radio audio, intercom audio, and sidetone (in transmit), and crew mic audio is derived from ICS instead of from the direct microphone pick up.

### **2.4.13 Intercom wiring**

The top connector (J2) is for the intercom and additional functions. See Appendix for intercom connection configurations. It is critical to the proper operation of this system to have this connector wiring made in accordance with these diagrams. Use 2- and 3-conductor, MIL-spec cable as shown. Connect the shields at the audio panel end only, and tie to the audio low inputs as shown.

### 2.4.13.1 Intercom Microphone Wiring

The PMA7000H is a 9-place intercom system; supporting seven passengers. Passengers 1 through 4 have individual mic audio high and low connections on J2. Passengers 5, 6 and 7 have mic audio high inputs, however the mic audio low connections are combined with Passenger 4 mic, on J2, Pin H. See Appendix D.

### 2.4.13.2 Push-to-Talk Intercom

The PMA7000H contains a push-to-talk intercom that can be used to enable intercom in cases where the ambient noise makes VOX operation impractical.

The PTT ICS Mode is enabled by grounding J2, Pin W, through a normally open SPST switch. This will prevent the IntelliVOX® from opening.

The pilot microphone will be placed on the intercom when J2, Pin X is connected to ground through a momentary, normally open switch. The copilot microphone will be placed on the intercom when J2, Pin Y is connected to ground through a momentary, normally open switch.

### 2.4.13.3 Entertainment Input

The PMA7000H has two INDEPENDENT music inputs. Entertainment input number 1 is J2 pins 15 (left channel) and 16 (right channel), WRT pin T, and is provided to the pilot and copilot. Entertainment number 2 is provided to the passengers at all times.

Entertainment 1 and 2 must be connected together in order for all positions to hear the same music source. We recommend installing a DPDT switch to allow isolation of the music sources if desired.

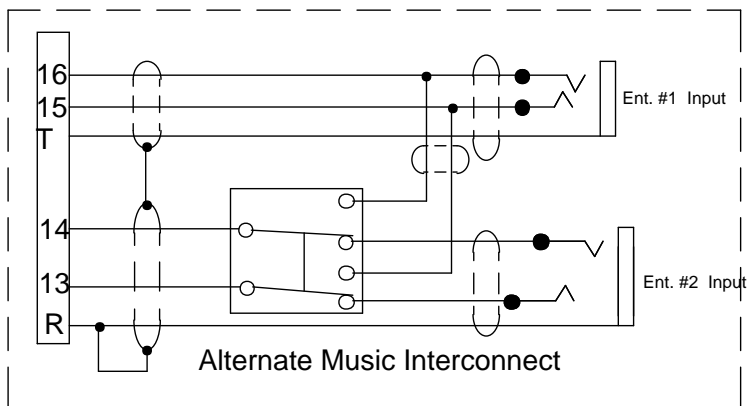

**NOTE:** Use the low level output of any additional entertainment device to connect to the audio panel. Maximum signal level is **2 VAC** p-p. **DO NOT** use a speaker-level output, this will cause internal damage in the audio panel.

#### 2.4.13.3.1 Entertainment Muting

The PMA7000H-system incorporates a "Soft Mute" system. This will mute the entertainment devices during ICS or radio conversation.

Any signal appearing in the unswitched audio inputs will mute the entertainment #1 & #2 sources when the intercom is in the ALL mode, even though the passengers may not hear the audio tone itself. Going to the ISOLATE or CREW mode will alleviate the passenger's music from muting.

**Caution:** Local oscillators and internal signals from entertainment equipment can cause undesired interference with other aircraft systems. Before takeoff, operate the entertainment devices to determine if there is any adverse effect within the aircraft systems. If any unusual operation is noted in flight, immediately switch off the entertainment devices.

All entertainment devices must be switched off for both takeoff and landing.

#### 2.4.13.3.2 Entertainment 2 Mute (Pin V)

The ICS button on the PMA7000H controls the muting (“Karaoke mode”) of entertainment source #1.

Connecting J2 pin V to ground through a SPST switch places the entertainment #2 music source into the Karaoke Mode. In this mode, incoming music and intercom conversation will not mute the music for the passengers’ intercom net. This allows uninterrupted music during casual conversation and at times when radio communications are of lesser importance.

See section 2.4.14 for alternative connection.

#### 2.4.13.4 Alternate Intercom Mode (Units above Serial Number Starting with “B”)

When the PMA7000H is toggled into “*Alternate Intercom Mode*,” using a switch connected to Bottom Connector Pin 14 is grounded, the passengers will NOT hear aircraft radios, even in the all mode. They will be able to converse with the crew. However, when the aircraft radio becomes active, the intercom audio from the passengers is muted, allowing the crew to focus on the radio.

### **2.5     *Marker Beacon Installation***

The marker beacon receiver is an option included in the PMA7000H.

#### **2.5.1    *Marker Antenna Installation***

A marker beacon antenna, appropriate to the type and speed of the aircraft, is required (not included). Refer to aircraft and antenna manufacturer's installation instructions, as well as AC43.13-2B (or later revision), Chapter 3, for information on proper antenna installation techniques. The marker beacon antenna must be mounted on the bottom of the aircraft.

#### **2.5.2    *External Marker Lights***

For installations that require external marker beacon lights, there are three outputs that can drive 12-Volt lamps only. The external output lamps are driven high (typically +9 VDC  $\pm$ 1.5 VDC unloaded, at MAX brightness) when active. Maximum source current per lamp is 125 mA. Voltage varies with photocell dimming.

#### **2.5.3    *Middle Marker Sense***

A Middle Marker Sense output signal is available from the 7000B to flight control systems. This function will not operate during the test mode. This output will go to +4.5 VDC ( $\pm$  1.0 VDC) when a valid Middle Marker signal is received. This output is J1, pin 2.

### **2.6     *Adjustments***

The PMA7000H is factory adjusted to accommodate the typical requirements for most aircraft configurations. There are five adjustments however, that will allow the installer to tailor the specific functions.

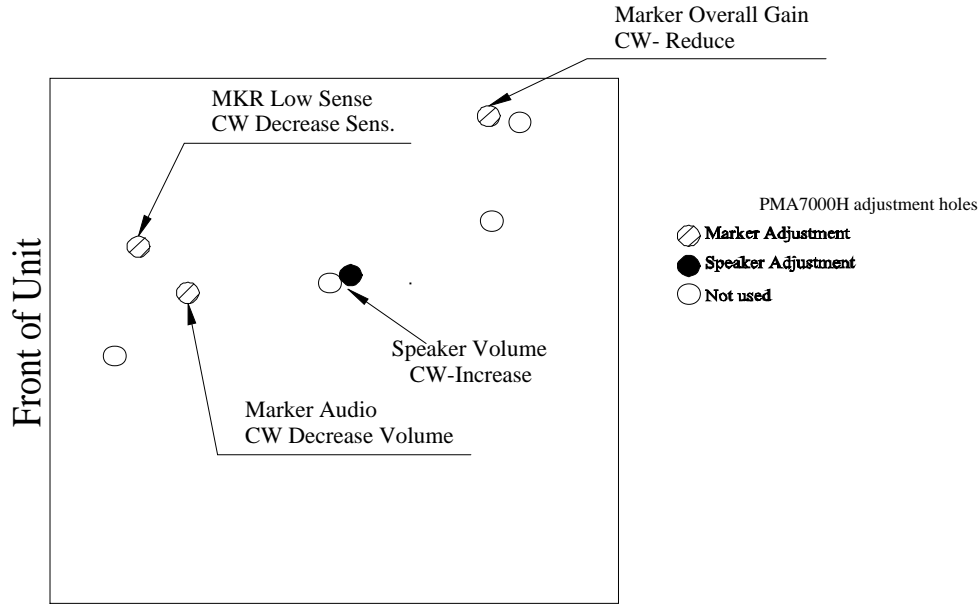

**Figure 2-3- PMA7000H Adjustments**

## 2.7 Communications Antenna Installation Notes

For best results while in Split Mode, it is recommended that the one VHF communications antenna is located on top of the aircraft while the other communications antenna is installed on the bottom. Any antenna relocation must be accomplished in accordance with AC 43.13-2A, aircraft manufacturers' recommendations and FAA-approved technical data.

**Warning:**

It is probable that radio interference will occur in the split mode when the frequencies of the two aircraft radios are adjacent, and/or the antennas are physically close together. **PS Engineering makes no expressed or implied warranties regarding the suitability of the PMA7000H in Split Mode.**

### 2.7.1 Hook Switches

While the Com 3 button acts as the hook switch for the pilot, additional hook switches must be installed to have full access to the cellphone system. The copilot hook switch is a SPST switch that connects pin L of J2 on the PMA7000H to ground to place the copilot mic audio on the Com 3 audio in duplex mode for cell phone operation.

PMA7000H J2, pin M is the passenger hook switch. Install a SPST switch in a location adjacent to each passenger headset where cellphone use is desired. When pin M is connected to ground through any switch, the passenger microphones are all on the Com 3/duplex system.

The hook switches are not active or required unless the audio panel is in Com 3 /Duplex mode, with pin J, J2 grounded.

The wireless communication "tel" system utilizes an intercom loop. Therefore, any time the cellphone is in use from the pilot or copilot side, pilot and copilot will lose intercom capability. In the ALL mode, when the passengers' activate the cell phone, the pilots will have intercom, and continue to hear and transmit over the avionics normally. However the passengers will not have intercom, because they are on the telephone.

See section 2.4.14 for alternative connection for the hook switches.

## 2.8 PMA7000H Pin assignments

<i>Pin</i>	<i>Function</i>	<i>Pin</i>	<i>Function</i>

**PS Engineering**  
PMA7000H Series Audio Selector Panel and Intercom System  
Installation and Operator's Manual

<i>Pin</i>	<i>Function</i>	<i>Pin</i>	<i>Function</i>
1	Audio GND	A	MKR Ant lo
2	MM Sense	B	MKR Ant hi
3	Pilot Phones (Rt)	C	White Lamp out
4	Amber Lamp Out	D	Lighting + 14V
5	Blue Lamp Out	E	Lighting lo
6	DME Audio	F	Lighting + 28V
7	No Connect	H	Com 2 Mic Audio
8	Pilot Mic Audio Hi	J	Com 3 Audio Hi
9	Com 1 Audio Hi	K	Com 3 Mic Audio
10	Com 2 Audio Hi	L	Com 1 load
11	AUX Audio In	M	Com 2 load
12	Nav 1 Audio Hi	N	No Connect
13	Nav 2 Audio Hi	P	Com 1 Mic Audio
14	Alternate Intercom Mode	R	Com 1 Mic Key
15	Com 3 Mic Key	S	ADF1 Audio Hi
16	Com 2 load	T	Unswitched audio in #1
17	Unswitched audio in #2	U	Unswitched #3
18	PA Mute	V	Com 2 Mic key
19	Com 1 load	W	Cockpit Speaker
20	Aircraft Power	X	Unswitched #4
21	Marker Audio Hi	Y	Pilot Mic Key
22	Speaker/Headphone lo	Z	A/C Ground

**Table 2-1 PMA7000H J1 Bottom Connector Pin Assignments**

<i>Pin</i>	<i>Function</i>	<i>Pin</i>	<i>Function</i>
1	Pilot Phones Left	A	AUX Control
2	Copilot Phones (L)	B	Copilot Phones Lo
3	Copilot Phones (Rt)	C	<b>Pass 5 Mic Hi</b>
4	PASS 1 Mic Hi	D	PASS 1 Mic Lo
5	PASS 2 Mic Hi	E	PASS 2 Mic Lo
6	PASS 3 Mic Hi	F	PASS 3 Mic Lo
7	PASS 4 Mic Hi	H	PASS 4 Mic Lo
8	Copilot Mic Audio Hi	J	Duplex Enable
9	Copilot Mic PTT	K	Copilot Mic Audio Lo
10	Swap	L	Copilot off hook
11	Pass Headphone (R)	M	PASS off hook



**PS Engineering**  
PMA7000H Series Audio Selector Panel and Intercom System  
Installation and Operator's Manual

<i>Pin</i>	<i>Function</i>	<i>Pin</i>	<i>Function</i>
12	Pass Headphone (L)	N	Pass Headphone Audio Lo
13	Ent 2 Input (Rt)	P	<b>Pass 6 Mic Hi</b>
14	Ent 2 Input (L)	R	Ent 2 Audio Lo
15	Ent. 1 Input (Rt)	S	<b>Pass 7 Mic Hi</b>
16	Ent. 1 Input (L)	T	Ent 1 Audio Lo
17	<b>ALT Pass HP Right</b>	U	<b>Pass 8 Mic Hi</b>
18	PA Activate	V	Mute 2
19	<b>ALT Pass Phones Left</b>	W	<b>ICS PTT Enable</b>
20	<b>Pilot CVR Output</b>	X	<b>Pilot ICS PTT</b>
21	<b>Copilot CVR Output</b>	Y	<b>Copilot ICS PTT</b>
22	<b>CVR Audio Lo</b>	Z	<b>ICS PTT Ground</b>

**Table 2-2 PMA7000H J2 Top Connector Pin Assignments (bold type indicates special pins for PMA7000H)**

## 2.9 Post Installation Checkout

After wiring is complete, verify power is ONLY on pin 20 of the J1 (bottom connector), and airframe ground on bottom connector pin Z. Failure to do so will cause serious internal damage and void PS Engineering's warranty.

## 2.10 Unit Installation

To install the PMA7000H, gently slide the unit into the mounting rack until the hold-down screw is engaged. While applying gentle pressure to the face of the unit, tighten the 3/32" hex-head in the center of the unit until it is secure. DO NOT OVER TIGHTEN.

**Warning:** Do not over-tighten the lock down screw while installing the unit in tray.  
**Internal damage will result.**

### 2.10.1 Required Test Equipment

In order to return an aircraft to service after installation of the PMA7000H, the installer must have access to a Marker Beacon signal generator:

- a. IFR NAV401L, NAV402AP, IFR4000
- b. TIC T-30D, T-36C

Equivalent test equipment is acceptable as long as the testing requirements can be met.

### 2.10.2 Operational Checkout

NOTE: The *IntelliVox*® is designed for ambient noise levels of 80 dB or above. Therefore some clipping may occur in a quiet cabin, such as without the engine running, in a hangar. This is normal.

1. Apply power to the aircraft and avionics.
2. Plug headsets into the pilot, copilot, and occupied passenger positions.
3. Verify fail-safe operation by receiving and transmitting on com 1 from the pilot position, with the audio panel power off. The Com audio will be present in the right ear cup only.
4. Verify that unswitched audio is present in right ear cup.
5. Switch on the unit by pressing the volume (VOL) knob.
6. Check intercom operation.

7. Check intercom Push-to-talk operation
8. Push the Com 1 Xmt select button (lower row).
9. Verify that both of the **Com 1** buttons light. Verify that transmit button LED (Light Emitting Diode) near the mic selector is not blinking. If the LED is blinking, stop testing and troubleshoot the microphone PTT installation.
10. Verify proper transmit and receive operation from the copilot position, noting that the copilot PTT switch allows proper transmission on the selected transceiver. Verify that the Com 1 Xmt button blinks when transmitting.
11. Verify that pushing the **COM 2** button causes the button to illuminate, and the Com 2 receiver to be heard. Verify operation on Com 1 from the pilot position.
12. Repeat for Com 2 and standard Com 3, (if installed).
13. Press and hold the Com 1 Xmt button. While holding the Com 1 button, press the Com 2 Xmt button. This places the unit in "split Mode;" Verify that the pilot can transmit and receive on Com 1, while the copilot transmits and receives on Com 2.
14. If the audio panel is installed with J2, pin J grounded, it is configured for duplex operation on Com 3. Verify that the pilot headset is connected to the cellular telephone system (if installed). Verify that by using the pilot side PTT, the pilot can transmit on the other selected radio (Com 1 or Com 2). Verify that the Com 3 Xmt LED blinks at about twice the rate of com 1, to indicate a duplex mode. The copilot has radio transmit capability in Com3 duplex mode, on the selected Com ( 1 or 2). However, he will have Com 3 capability if the copilot hook switch is grounded.
15. Verify proper operation of all receiver sources by selecting them using the appropriate button. The button illuminates to show which source is in use.
16. Push the SPR button. Verify that all selected audio is heard in the cockpit speaker. Verify that the audio mutes when the mic is keyed.
17. Verify that the appropriate LED in the lower right side blinks when either push to talk is keyed.
18. Verify proper Intercom system operation in the **ALL**, **ISO** and **CREW** modes (see Table 3-1).
19. Verify that the audio selector panel system does not adversely affect any other aircraft system by systematically switching the unit on and off, while monitoring the other avionics and electrical equipment on the aircraft.

#### 2.10.2.1 Marker Checkout

1. Connect a ramp generator at the antenna end of the marker coax. With the unit under test in HI sensitivity, verify that a 160  $\mu$ V, modulated 95% with 1300 Hz, signal will illuminate the amber (M) marker light, and that marker audio is present in the headphones when the Marker Audio (M) push-button has been depressed. Select SPR for speaker to verify marker audio availability on the cabin speaker. Verify that the white (I) and blue (O) lights will illuminate within  $\pm$  3dB of the amber lamp, with 3000 HZ and 400 Hz applied, respectively.
2. Repeat with the unit in LOW sensitivity, with 430  $\mu$ Volts applied.
3. Connect the marker antenna and verify proper operation.

#### 2.10.3 Receiver Sensitivity

Although the receiver meets FAA TSO-C35d sensitivity specifications, the sensitivity has been adjusted to meet real world requirements (150 $\mu$ V and 430 $\mu$ V, soft). This will usually eliminate the need for the avionics shop to reduce the sensitivity in the field so as to prevent early detection of the marker beacons. If your particular installation requires more or less sensitivity, see adjustment section 2.6, and figure 2-1.

#### 2.11 Cellular Interface Checkout

When a wireless telecommunication system is installed and the unit configured for duplex, a dial tone will appear in the headset of the pilot when the COM 3 Xmt selector activated. In "ALL" intercom mode, a dial tone will be heard whenever the copilot or passenger's hook switch is closed.

## **2.12 Final Inspection**

Verify that the wiring is bundled away from all controls and no part of the installation interferes with aircraft control operation. Move all controls through their full range while examining the installation to see that no mechanical interference exists. Verify that the cables are secured to the aircraft structure in accordance with good practices, with adequate strain relief. Ensure that there are no kinks or sharp bends in the cables and coaxial cables. Verify that the cables are not exposed to any sharp edges or rough surfaces, and that all contact points are protected from abrasion.

Complete logbook entry, and other documentation as required such as FAA Form 337, weight and balance computation. Sample text for FAA Form 337, and instructions for continuing airworthiness can be found in Appendix F.

Return completed warranty registration application to PS Engineering, or register online at [www.ps-engineering.com/support.shtml](http://www.ps-engineering.com/support.shtml).

## Section III OPERATION

### GENERAL INFORMATION

#### 3.1 SCOPE

This section provides detailed operating instructions for the PS Engineering PMA7000H, Audio Selector Panel/Intercom Systems. Please read it carefully before using the equipment so that you can take full advantage of its capabilities.

This section is divided into four sections covering the basic operating areas of the PMA7000H systems. They are Audio Selector, Transceiver Selection, Intercom, and Marker Beacon Receiver (Marker version only).

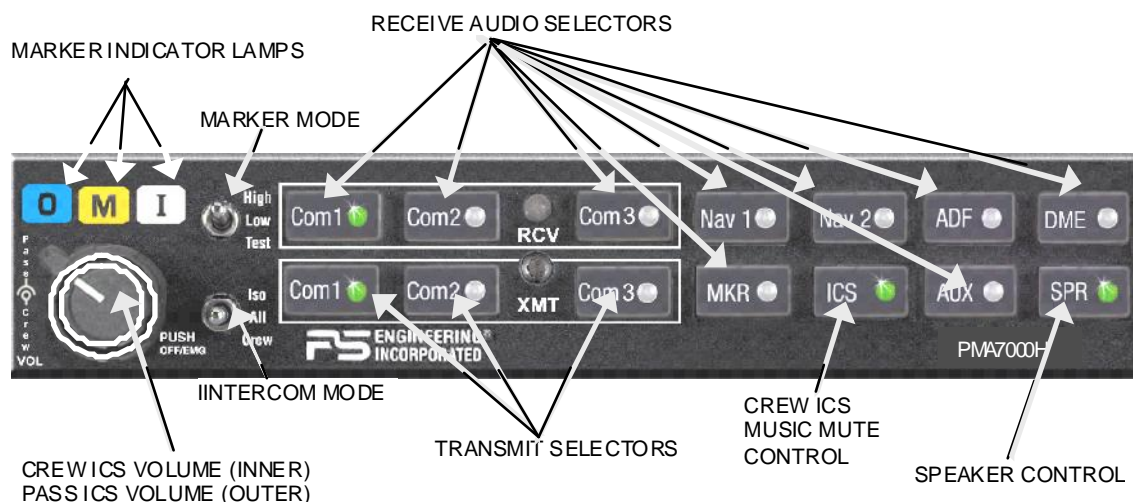

Figure 3-1 PMA7000H controls

#### 3.2 Power Switch (EMG-Fail Safe Operation)

Unit power is turned on and off by pushing the volume knob. In the OFF or "EMG" position, the pilot is connected directly to Com 1 and to the critical unswitched input. This allows communication capability regardless of unit condition. Any time power is removed or turned OFF, the audio selector will be placed in the fail-safe mode.

The power switch also controls the audio selector panel functions, intercom and marker beacon receiver.

#### 3.3 Microphone (XMT) Selection (All models)

There are six pushbuttons associated with the communications transceivers. The lower buttons control which transceiver is selected for transmit.

The PMA7000H gives priority to the pilot's PTT. If the copilot is transmitting, and the pilot presses his PTT, the pilot's microphone will be heard over the selected com transmitter.

The PMA7000H has an automatic selector mode. Audio from the selected transceiver is automatically heard in the headsets and speaker (if selected). You can check this function by switching from COM 1 to COM 2 and watch the selected audio light on the selector change from COM 1 to COM 2. This ensures the pilot will *always* hear the audio from the transceiver he is transmitting on.

When switching from COM 1 to COM 2, while COM 2 audio had been selected, Com 1 audio will continue to be heard. This eliminates the pilot having to switch Com 1 audio back on, if desired.

When switching from COM 1 to COM 2 while Com 2 has NOT been selected, Com 1 audio will be switched off. In essence, switching the mic selector will not effect the selection of Com receiver audio.

When the duplex enable, or TELEPHONE mode is implemented during installation, Com 3 becomes the "TEL" position. This is the pilot's "hook" switch, when the system is interfaced to an appropriate approved wireless telecommunication system, such as the AirCell system. Selecting Com 3 for transmit places the pilot microphone and headphones on the cellphone. The pilot PTT will switch the pilot mic to the other selected com transceiver, and allow continued aircraft communications to continue.

The copilot will also be able to transmit on the other selected radio with his PTT as well.

NOTE: Placing the mic selector switch in the COM 3 –TEL– mode will disable pilot and copilot intercom, as the intercom circuit is transferred to the telephone use. In crew or ISO mode, placing the switch in TEL mode removes the passengers access to the telephone.

### **3.3.1 Swap Mode (Switch from Com 1 to Com 2 remotely)**

With a yoke mounted, momentary switch, the pilot can change from the current Com transceiver to the other by depressing this switch. To cancel "Swap Mode," the pilot may either press the yoke mounted switch again, or select a different Com with the XMT buttons. .

## **3.4 Audio Selector (All models)**

Receiver audio is selected through seven momentary, push-button, backlit switches. You will always hear the audio from the transceiver that is selected for transmit.

The users can identify which receivers are selected by noting which of the green switch LEDs are illuminated. Push buttons labeled **Nav 1**, **Nav 2**, **MKR** (Marker), **ADF**, **DME**, **AUX** (auxiliary), and **SPR** (Speaker) are "momentary" type switches. When one of these buttons is pressed, be active, and the LED will illuminate. Press the switch again and it be in the "off" position and remove that receiver from the audio.

### **3.4.1 Speaker Amplifier**

The "SPR" in the push-button section stands for speaker. This switch will place all selected audio on the cockpit speaker when this switch is selected. NOTE: Except for the unswitched audio, the speaker amplifier is not active in the "Split Mode."

Unswitched audio, (autopilot disconnect, altimeter warning, etc.) will come through the speaker regardless of the speaker button position.

#### **3.4.1.1 Public Address Function**

To access PA function, a switch is installed to connect the top connector, pin 18, to ground. This places the *pilot* microphone on the speaker output (Pin W) when the PTT is pushed. The copilot can continue to use the selected com radio.

We recommend that the switch transfer the audio from the cockpit speaker to a cabin speaker for public address. This will prevent feedback.

## **3.5 Split Mode**

The split mode can be activated at any time by pressing the desired combination of XMT buttons. For instance, to activate a Com 1/Com 2 split, press and hold the Com 1 button, and then press the Com 2 button while holding the Com 1 button. This places the pilot on Com 1 and the Copilot on Com 2.

Split mode for Com 3 is possible with pilot on Com 1, copilot on Com 2 or 3, if telephone is not enabled.

Pilot on Com 2 or Com 3 and Copilot on Com 1 is not possible.

**Note:**

Due to the nature of VHF communications signals, and the size constraints in general aviation aircraft, it is probable that there will be some bleed-over in the Split mode, particularly on adjacent frequencies.

PS Engineering makes no warranty about the suitability of Split Mode in all aircraft conditions.

**Note:** Split Mode does not turn off other (Nav, ADF, etc.) selected audio to **pilot**. However, the copilot will only hear the selected communications receiver.

### 3.5.1 Split Mode ICS

In split mode, the pilot and copilot are usually isolated from each other on the intercom, simultaneously using their respective radios. Depressing the **ICS** button in Split Mode will activate VOX intercom between the pilot and copilot positions. This permits intercommunication when desired between the crew. Pressing the ICS button again disables this crew intercom function.

## 3.6 Intercom Operation

### 3.6.1 IntelliVox® VOX-Squelch

No adjustment of the *IntelliVox*® squelch control is necessary. There is no field adjustment. Through three individual signal processors, the ambient noise appearing in all six microphones is constantly being sampled. Non-voice signals are blocked. When someone speaks, only their microphone circuit opens, placing their voice on the intercom.

The system is designed to block continuous tones, therefore people humming or whistling in monotone may be blocked after a few moments.

For consistent performance, any headset microphone **must** be placed within ¼-inch of your lips, preferably against them. (ref: *RTCA/DO-214, 1.3.1.1 (a)*).

It is also a good idea to keep the microphone out of a direct wind path. Moving your head through a vent air stream may cause the *IntelliVox*® to open momentarily. This is normal.

The *IntelliVox*® is designed to work with normal aircraft cabin noise levels (80 dB and above). It loves airplane noise! Therefore, it may not recognize speech and clip syllables in a quiet cabin, such as in the hangar, or without the engine running. This is normal.

For optimum microphone performance, PS Engineering recommends installation of a Microphone Muff Kit from Oregon Aero (1-800-888-6910). This will not only optimize VOX performance, but will improve the overall clarity of *all* your communications.

**Table 3-1 Mic Muff™ Part Numbers**

Manufacturer	Model	Mic Muff™ Part Number
Bose	Dynamic	90010
	Electret	90015
	M87 Dynamic	90020
David Clark	H10-30	90010
	H10-20, H10-40	90015
	H10-13.4	90015
Lightspeed	15K & 20K	90015
Peltor	7003	90010
	7004	90015
Pilot	11-20 & 11-90	90015
Sennheiser		90015
Telex	Airman 750	90015
	AIR3000	90010

### 3.6.2 Intercom Volume Control

The inner volume control knob adjusts the loudness of the intercom for the pilot and copilot. It has no effect on selected radio levels, music input levels or passengers' volume level.

The outer volume control knob controls intercom volume or the passengers. It has no effect on radio or music levels.

Adjust the radios and intercom volume for a comfortable listening level. Most general aviation headsets today have built-in volume controls; therefore, volume also can be further adjusted at the individual headset.

#### 3.6.2.1 Mono headsets in Stereo Installation

All passenger headsets are connected in parallel. Therefore, if a monaural headset is plugged in to a PMA7000H Stereo installation, one channel will be shorted. Although no damage to the unit will occur, all passengers will lose one channel, unless they switch to the "MONO" mode on the headset. PS Engineering modifies headsets to add stereo capability, using high-fidelity speakers. Contact factory for details.

### 3.6.3 Intercom Modes

The lower switch on the left side is a 3-position mode switch that allows the pilot to tailor the intercom function to best meet the current cockpit situation. The description of the intercom mode function is valid only when the unit is not in the "Split" mode. Then, the pilot and copilot intercom is controlled with the ICS button.

**ISO:** (Up Position): The pilot is isolated from the intercom and is connected only to the aircraft radio system. He will hear the aircraft radio reception (and sidetone during radio transmissions). Copilot will hear passengers' intercom and Entertainment 1, while passengers will hear copilot intercom and Entertainment 2. Neither will hear aircraft radio receptions or pilot transmissions.

**ALL:** (Middle Position): All parties will hear the aircraft radio and intercom. Crew will hear Entertainment 1, passengers will hear Entertainment 2. During any radio or intercom communications, the music volume automatically decreases. The music volume increases gradually back to the original level after communications have been completed.

**CREW** (Down Position): Pilot and copilot are connected on one intercom channel and have exclusive access to the aircraft radios. They may also listen to Entertainment 1. Passengers can continue to communicate with themselves without interrupting the Crew and also may listen to Entertainment 2.

Anytime the PMA7000H is in either the COM 1/COM 2, COM1/ COM3 ("Split Mode"), the pilot and copilot intercom is controlled with the ICS button. The passengers will maintain intercommunications, but never hear aircraft radios.

**PS Engineering**  
PMA7000H Audio Selector Panel and Intercom System  
Installation and Operator's Manual

**3.6.3.1 Alternate Intercom Mode (Serial Number beginning with letter "B" and above)**

When the PMA7000H is toggled into "Alternate Intercom Mode," using a switch connected to Bottom Connector Pin 14 is grounded, the passengers will NOT hear aircraft radios, even in the all mode. They will be able to converse with the crew. However, when the aircraft radio becomes active, the intercom audio from the passengers is muted, allowing the crew to focus on the radio.

Mode	Pilot Hears	Copilot Hears	Passenger Hears	Telephone	Comments
<b>Isolate</b>	A/C Radios Pilot Sidetone (during radio transmission) Entertainment 1 is Muted	Copilot and passenger intercom Entertainment #1	Passenger and Copilot intercom Entertainment #2	"Phone Booth" mode Pilot has exclusive use of the telephone. In TEL, Pilot & Copilot connected to Com 1 for PTT TX and receive. Others hear Tel if off hook.	This mode allows the pilot to communicate without the others bothered by the conversations. Copilot and passengers can continue to communicate and listen to music
<b>All</b>	Pilot Copilot A/C Radio Passengers Entertainment #1	Copilot Pilot A/C Radio Passengers Entertainment #1	Passengers Pilot Copilot A/C Radio Entertainment #2	All have access to phone through Hook Switch. Pilot access through TEL switch. All hear telephone audio if off hook.	This mode allows all on board to hear radio reception as well as communicate on the intercom. Music and intercom is muted during intercom and radio communications
<b>Crew</b>	Pilot Copilot A/C Radio Entertainment #1	Copilot Pilot A/C Radio Entertainment #1	Passengers Entertainment #2	Pilot and copilot don't have phone access, unless mic sel in TEL. Passengers have phone through Hook Switch, Passengers hear phone audio.	This mode allows the pilot and copilot to concentrate on flying, while the passengers can communicate amongst themselves.
<b>Alternate Intercom Mode</b>	Pilot Copilot A/C Radio Passengers (when radio silent) Entertainment #1	Pilot Copilot A/C Radio Passengers (when radio silent) Entertainment #1	Passengers Pilot Copilot Entertainment #2	All have access to phone through Hook Switch. Pilot access through TEL switch. All hear telephone audio if off hook.	This mode allows the crew to hear radio reception (but not bother the passengers) as well as communicate on the intercom. Passenger mics are removed from the crew audio when the radios are active.

**Table 3-2 Intercom Modes**

**3.6.3.2 Entertainment Input**

The audio selector panel has provisions for two separate entertainment input devices. Music 1 feeds the pilot and copilot positions. They operate independently in the PMA7000H. The volume control does not affect the music level.

While in the ISO (Isolate) mode, the copilot will hear Entertainment 1 while the four passengers will hear Entertainment #2. The pilot will hear entertainment 1, at a muted level. In normal operation, whenever a person speaks, or if the aircraft radio becomes active, the music will automatically mute and then will gradually return to the original listening level when the intercom or radio conversation ceases.

When in the ALL mode, pilot and copilot will hear Entertainment 1 input while all passengers will hear the Entertainment 2 source. While in the CREW mode, pilot and copilot will hear entertainment input #1 while the passengers may listen to entertainment input #2.

**3.6.3.3 Soft Mute and Soft Mute inhibit**

The Soft Mute feature assures that the aircraft radio transmissions and other audio will not be missed due to entertainment playing. When there is radio reception or intercom conversation, the music level is dropped to a low, or background level. When the radio or intercom traffic ceases, the level gradually returns to normal.

The front panel ICS switch controls muting of entertainment source #1 (for pilot and copilot). Pushing this button places the ICS in Karaoke (or sing along) mode, which inhibits the soft mute feature. This allows the



music to continue uninterrupted by intercom or radio traffic when cockpit workload is appropriate. Pushing the button again will release the mute inhibit function.

The passenger music, source #2, can be placed in the Karaoke mode if a remote switch is installed in the aircraft. See wiring information for details.

### **3.7 Push-to-Talk Intercom Mode**

The PMA7000H has a push to talk intercom function available for the crew positions. When the external PTT ICS enable switch is activated, the pilot and copilot must use the remote ICS PTT switches to talk on the intercom. Passenger intercom is normal.

### **3.8 Telephone Mode**

The Com 3 mode can serve as a full duplex interface for telephone systems such as AirCell or portable cellular phones with earpiece jacks, if the installation is correctly configured. When interfaced with an approved airborne telecommunications system, the PMA7000H can serve as an audio control and distribution center. Each intercom position has a "hook switch." The pilot's hook switch is the "Com 3" button on the audio panel, the others are discrete switches mounted adjacent to the headset jacks. When Com 3 is active in the duplex mode, the TX button will blink about twice as fast as the normal transmit rate.

When the intercom is in **ALL** mode, the pilot can speak on the phone only if the **Com 3 is selected for transmit (Com 3 Xmt button activated)**. If any passenger places his or her switch into the "off-hook" position all passengers will also be heard on the phone. All will hear selected audio. Com 1 audio is automatically heard in the headsets. The pilot and copilot will have transmit capability on the other selected transceiver Com 1 or 2, simply by using their respective PTT switch.

In **CREW** mode, the pilot and copilot may use the telephone, with their respective hook switch (the pilot selects Com 3 on the Xmt selector). Any passenger who places their switch into the off-hook position will also have access to the phone, and all passengers will hear the conversation.

In **ISO** intercom mode, when the PMA7000H is in the **Com 3** mode, the pilot position is in the "Phone Booth." Only the pilot will hear the telephone, and only he will be heard. He will also have access to Com 1 or 2, and will transmit on that radio using the PTT. All selected audio is provided. If any other passenger goes "off hook" they will hear the phone.

**Note: Because the cellphone uses an intercom circuit, all stations on that circuit will lose intercom capability when the cellphone is in use.**

### **3.9 Marker Beacon Operation**

The optional Marker Beacon Receiver uses visual and audio indicators to alert you when the aircraft passes over a 75 MHz transmitter.

The Blue lamp, labeled "O," is the Outer Marker lamp and has an associated 400 Hertz 'dash' tone. The lamp and tone will be keyed at a rate of two tones/ flashes per second when the aircraft is in the range of the Outer Marker Beacon.

The Amber lamp, labeled "M," is the Middle Marker lamp and is coupled with a 1300 Hertz tone. It is keyed alternately with short 'dot' and long 'dash' bursts at 95 combinations per minute.

The White lamp, labeled "I," is the Inner marker and has a 3000 Hertz 'dot' tone. The lamp and tone will be keyed at a rate of six times per second.

The audio from the Marker Beacon Receiver can be heard by selecting the "MKR" push-button switch. To adjust the volume level, there is a service adjustment located on the top of the unit.

A three-position switch is used to set the receiver sensitivity and to test the indicator lamps. Use "**HI**" sensitivity initially. This allows you to hear the outer marker beacon about a mile out. Then select the "**LO**" sensitivity to give you a more accurate location of the Outer Marker. The momentary down switch position is marker test, labeled "T/M" and illuminates all three lamps simultaneously to assure the lamps (internal and external) are in working order. TST does not activate MM sense output.

**PS Engineering**  
PMA7000H Audio Selector Panel and Intercom System  
Installation and Operator's Manual

Pressing the marker mode select down (to "T/M") will cause the marker audio to mute for that beacon. The next beacon received will re-activate the audio.

## Section IV- Warranty and Service

### 4.1 Warranty

In order for the factory warranty to be valid, the installations in a certified aircraft must be accomplished by an FAA-(or other ICAO agency) certified avionics shop and authorized PS Engineering dealer. If the unit is being installed by a non-certified individual in an experimental aircraft, a factory-made intercom harness must be used for the warranty to be valid.

PS Engineering, Inc. warrants this product to be free from defect in material and workmanship for a period of two (2) years from the date of sale. During the first **twelve (12) months** of the two-year warranty period, PS Engineering, Inc., at its option, will send a replacement unit at our expense if the unit should be determined to be defective after consultation with a factory technician. For the remaining **twelve (12) months** of the two-year warranty period, the unit must be returned to PS Engineering, Inc., or an authorized warranty service facility, for no-cost repair.

All transportation charges for returning the defective units are the responsibility of the purchaser. All domestic transportation charges for returning the exchange or repaired unit to the purchaser will be borne by PS Engineering, Inc. The risk of loss or damage to the product is borne by the party making the shipment, unless the purchaser requests a specific method of shipment. In this case, the purchaser assumes the risk of loss.

This warranty is not transferable. Any implied warranties expire at the expiration date of this warranty. PS Engineering SHALL NOT BE LIABLE FOR INCIDENTAL OR CONSEQUENTIAL DAMAGES. This warranty does not cover a defect that has resulted from improper handling, storage or preservation, or unreasonable use or maintenance as determined by us. This warranty is void if there is any attempt to disassemble this product without factory authorization. This warranty gives you specific legal rights, and you may also have other rights, which may vary from state to state. Some states do not allow the exclusion of limitation of incidental or consequential damages, so the above limitation or exclusions may not apply to you.

All items repaired or replaced under this warranty are warranted for the remainder of the original warranty period. PS Engineering, Inc. reserves the rights to make modifications or improvements to the product without obligation to perform like modifications or improvements to previously manufactured products.

### 4.2 Factory Service

The units are covered by a two-year limited warranty. See warranty information. Call PS Engineering, Inc. at (865) 988-9800 before you return any unit. This will allow the service technician to provide any other suggestions for identifying the problem and recommend possible solutions.

After discussing the problem with the technician and you obtain a Return Authorization Number, ship product to:

PS Engineering, Inc.  
Attn: Service Department  
9800 Martel Rd  
Lenoir City, TN 37772  
(865) 988-9800 FAX (865) 988-6619  
Email: support@ps-engineering.com

**Units that arrive without an RMA number, or telephone number for a responsible contact, will be returned un-repaired. PS Engineering is not responsible for items sent via US Mail.**

Appendix A – PMA7000H Installation Drawing

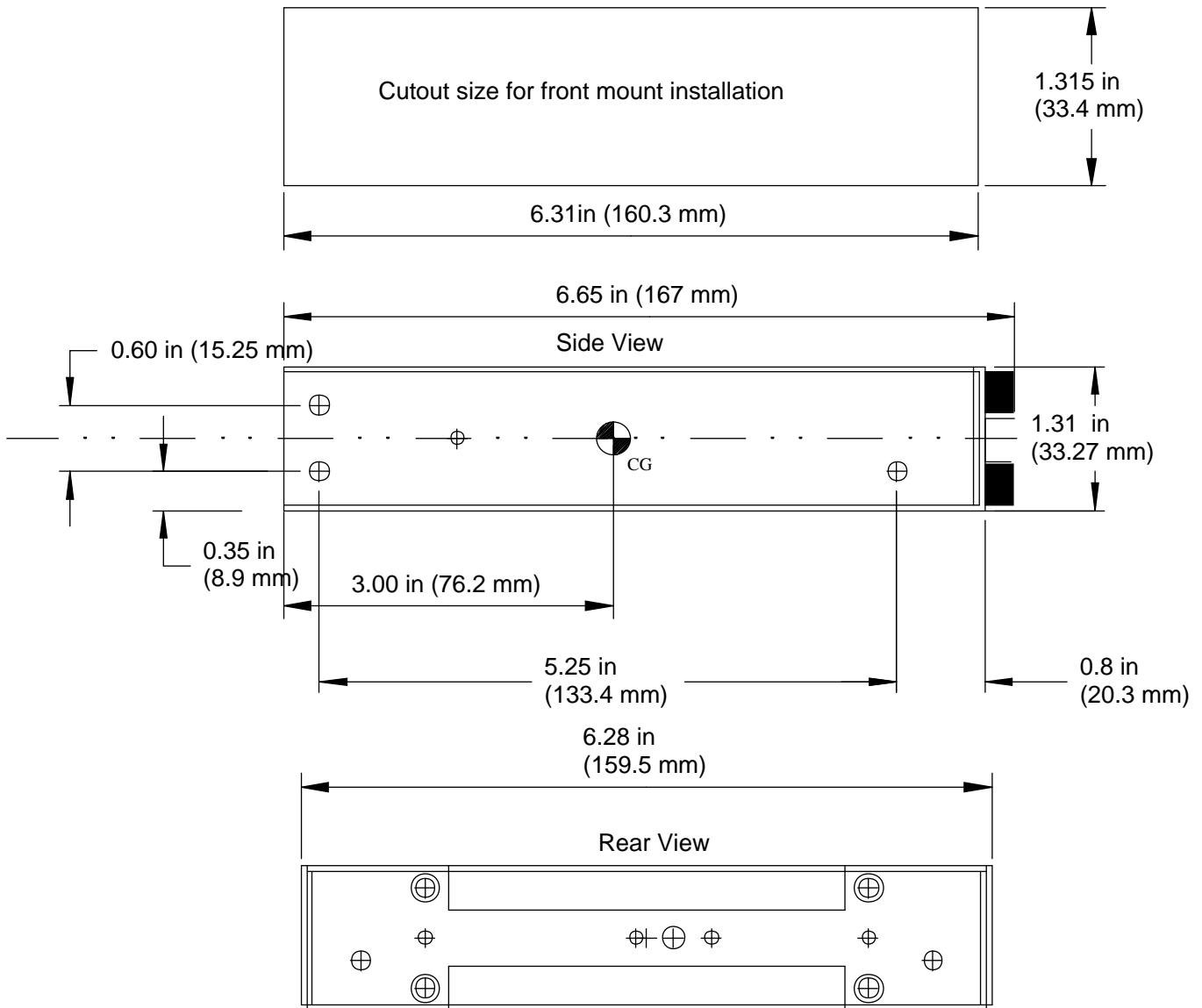

Weight: 1.5 lb with tray and connectors ( .68 kg)

Connector viewed from the rear

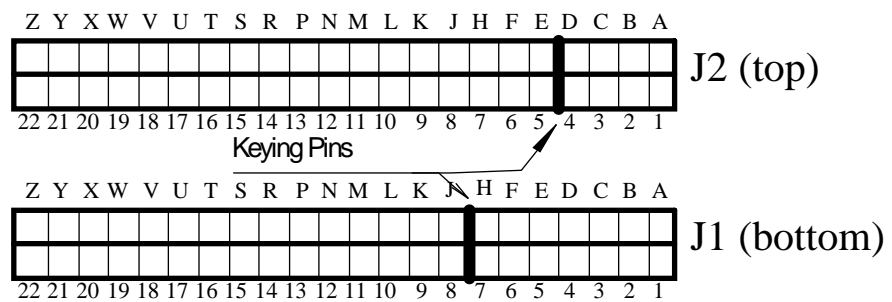

## Appendix B Bottom Connector Interconnect

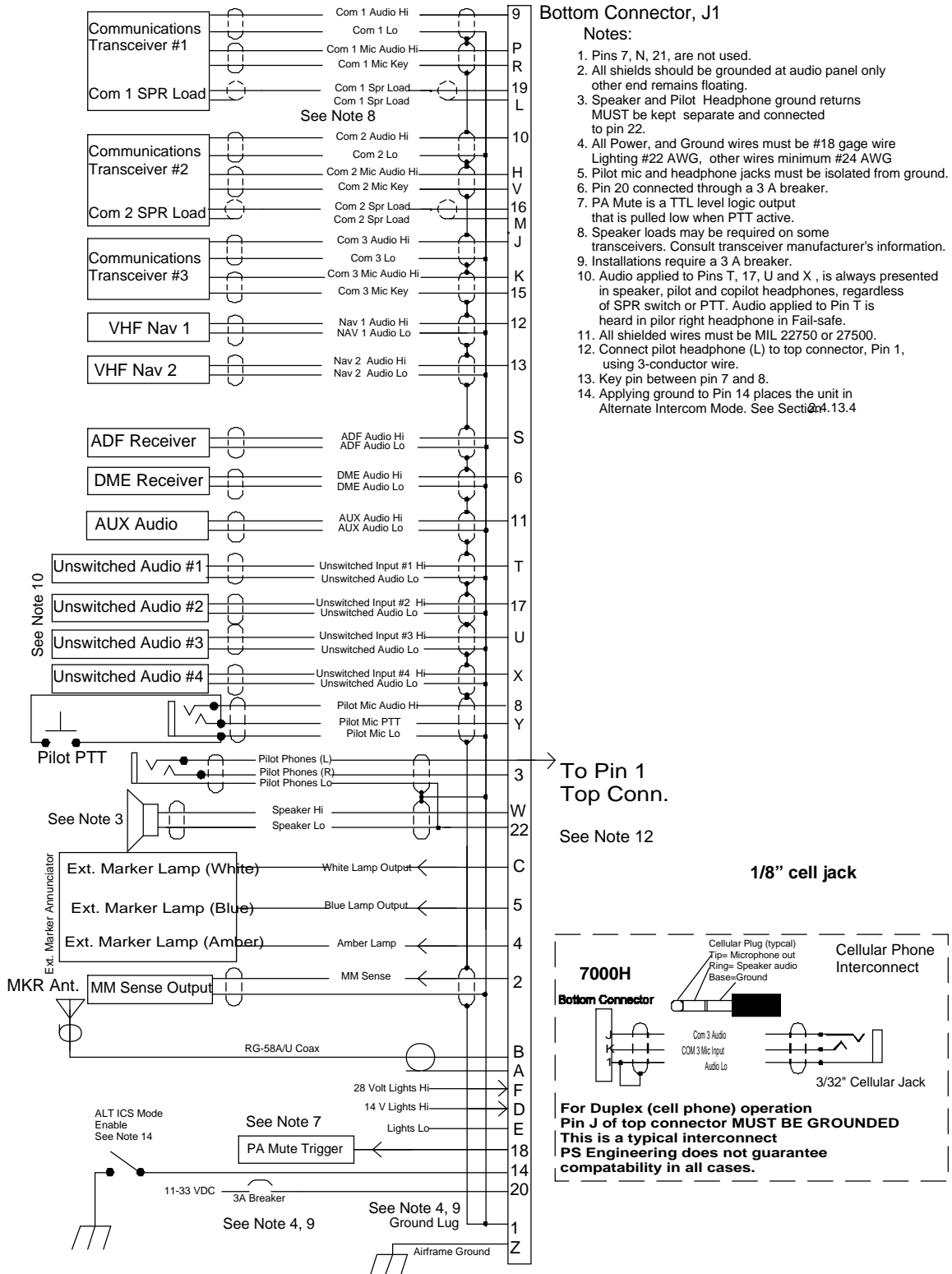

## Appendix C Top Connector Interconnect

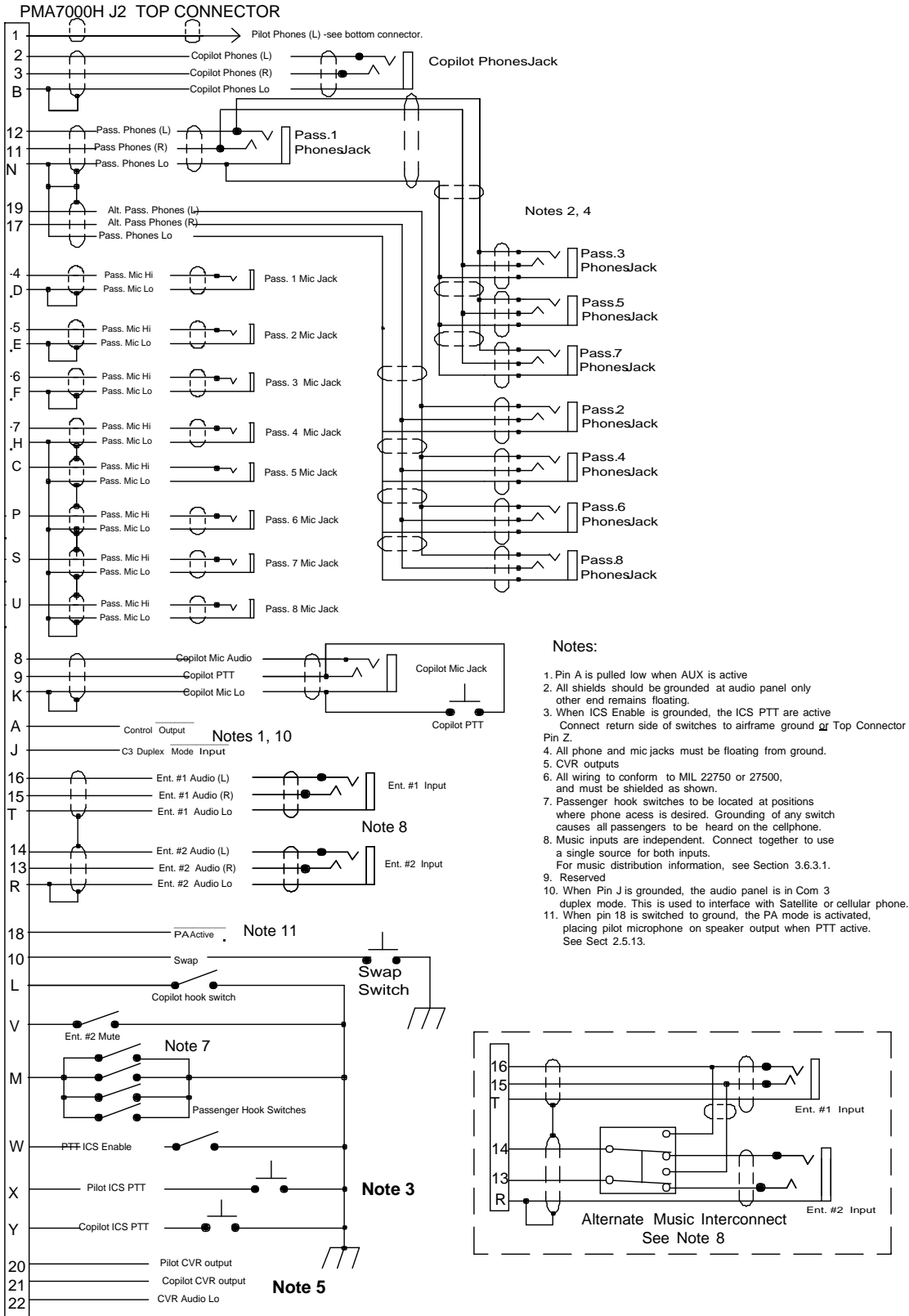

Passenger 8 only available in units with serial numbers beginning with "B and above.

## Appendix D- Instructions for FAA Form 337 and continuing airworthiness

### 8.1 Instructions for FAA Form 337, Audio Panels

One method of airworthiness approval is through an FAA Form 337, *Major Repair and Alteration (Airframe, Powerplant, Propeller, or Appliance)* In the case of the PMA7000H, you may use the following text as a guide.

Installed audio selector and 6-place intercom, PS Engineering PMA7000H, part number 7000 (X) in ( location ) at station \_\_\_\_\_. Installed per *AC43.13-2, Chapter 2, paragraph 23* (Instrument Panel Mounting). Installed per PS Engineering *Installation Operators Manual* p/n 200-780-(XXXX), revision ( ), dated ( ).

These units are FAA-Approved under TSO C50c for audio amplifiers, and/or TSO C35d for Marker Beacon Receivers, and meets appropriate environmental qualifications outlined in RTCA DO-160D as appropriate or this aircraft.

Interface to existing aircraft radios in accordance with installation manual and in compliance with practices listed in *AC43.13-2, Chapter 2*. All wires are Mil-Spec 22759 or 27500. Connection to aircraft dimmer bus is \_\_\_\_\_. Power is supplied to the unit through a 3A circuit breaker (type and part number), and total electrical load does not exceed \_\_\_\_\_% of the electrical system capacity with the PMA7000H added.

Aircraft equipment list, weights and balance amended. Compass compensation checked. A copy of the operation instructions, contained in PS Engineering document 200-780-( ), revision ( ), dated ( ), is placed in the aircraft records. All work accomplished listed on Work Order\_\_\_\_\_.

### 8.2 Instructions for Continuing Airworthiness, Audio System

Sample ICA Checklist for PS Engineering Audio System:

Section	Item	Information
1	Introduction	Installation of audio control panel with integrated marker beacon receiver and intercommunications system.
2	Description	Installation as described in manufacturer's installation manual referenced on FAA Form 337, including interface with other avionics audio as required.
3	Controls	See installation and operator's guide referenced on FAA Form 337.
4	Servicing	None Required
5	Maintenance Instructions	On Condition, no special instructions
6	Troubleshooting	In the event of a unit problem, place the unit into "off," "fail-safe" and/or "emergency" mode. This allows pilot communications using COM 1. Follow checkout instructions in the installation manual referenced on the FAA Form 337. For a specific unit fault, contact the manufacturer at (865) 988-9800 for special instructions.
7	Removal and replacement information	<b>Removal:</b> Using a 3/32" Allen-head wrench, carefully unscrew the locking screw located in the center of the unit. While turning the wrench CCW, gently pull on the EDGES of the bezel until the unit is free from the mounting tray. <b>Installation:</b> Engage the locking screw at the back. Turn the locking screw CW, while applying slight pressure to the edges of the bezel. Do not over tighten!
8	Diagrams	Not applicable
9	Special Inspection Requirements	Not Applicable
10	Protective Treatments	Not Applicable
11	Structural Data	Not Applicable
12	Special Tools	None
13	Not Applicable	Not Applicable
14	Recommended Overhaul Periods	None
15	Airworthiness Limitations	Not Applicable
16	Revision	To be determined by installer

## Appendix E RTCA DO160C (EUROCAE ED-14) Environmental Qualification Form

Audio Selector Panel/Intercom/Marker Beacon Receiver

Part Number: 7000( )

FAA TSO Number: C50c, C35d Class A, JTSO 2C35d and JTSO C50c

Manufacturer: PS Engineering Incorporated 9800 Martel Road Lenoir City TN 37772

Conditions	Section	Conducted Tests
Temperature and Altitude	4.0	Equipment tested to CAT A1 & D1
Low Temperature	4.5.1	-55° C Survival, -15°C Low Operating (A1)
High Temperature	4.5.2	+85°C Survival, +70°C High Short Time Operating
In-flight Loss of Cooling	4.5.4	Not Applicable, no cooling required
Altitude	4.6.1	50,000' unpressurized (D1)
Decompression	4.6.2	Not Applicable
Overpressure	4.6.3	Not Applicable
Temperature variation	5.2	Equipment tested to Category C
Humidity	6.0	Equipment tested to Category A
Shock	7.0	Equipment tested to Operational test only
Operational	7.2	Equipment tested to Operational test only
Crash Safety	7.3	Equipment tested to Operational test only
Vibration	8.0	Equipment tested to Category M & N
Explosion	9.0	Category X, not tested
Waterproofness	10.0	Category X, not tested
Fluids Susceptibility	11.0	Category X, not tested
Sand and Dust	12.0	Category X, not tested
Fungus	13.0	Category X, not tested
Salt Spray	14.0	Category X, not tested
Magnetic Effect	15.0	Equipment tested to Category Z
Power input	16.0	Equipment tested to Category B
Voltage Spike	17.0	Equipment tested to Category B
Audio Frequency Susceptibility	18.0	Equipment tested to Category B
Induced Frequency Susceptibility	19.0	Equipment tested to Category B
Radio Frequency Susceptibility	20.0	Equipment tested to Category T
Radio Frequency Emission	21.0	Equipment tested to Category B
Lightning Induced Transient Susceptibility	22.0	Equipment tested to Category K
Lightning Direct Effects	23.0	Category X, not tested
Icing	24.0	Category X, not tested