



SERVO DRIVE

FlexDrive Servo Control

Installation & Operating Manual

Table of Contents

Section 1	
General Information	1-1
CE Compliance	1-1
Limited Warranty	1-1
Product Notice	1-2
Safety Notice	1-2
Section 2	
Product Overview	2-1
Section 3	
Receiving and Installation	3-1
Receiving & Inspection	3-1
Location Considerations	3-1
Mechanical Installation	3-1
Electrical Installation	3-2
System Grounding	3-2
Power Disconnect	3-4
Protection Devices	3-4
X1 Power Connections	3-5
X1 Motor Connections	3-10
M-Contactor	3-10
Motor Thermostat	3-11
X1 Dynamic Brake Resistor	3-11
X1 +24VDC Logic Supply	3-12
X3 Control Inputs & Digital I/O Connections	3-12
X6 RS232 / 485 Connections	3-15
X7 Simulated Encoder Output	3-18
X8 Resolver Feedback	3-18
X9 Handwheel (Encoder) Installation	3-19
X9 Encoder w/Hall Tracks	3-21
Section 4	
Switch Setting and Start-Up	4-1
Switch AS1 Settings	4-1
Start-Up Procedure	4-3
Power Off Checks	4-3
Power On Checks	4-3

Section 5	
Operation	5-1
Installing Software on your PC	5-1
Minimum system requirements	5-1
Installation	5-1
Host Ccommunications Setup	5-1
Using The Setup Wizard	5-3
Set up Software	5-5
Motor	5-6
Control	5-6
Operating Mode	5-7
Current Parameter	5-8
Velocity Parameter	5-8
Drift	5-9
Autotune	5-9
Main Menu Choice Descriptions	5-10
File	5-10
Edit	5-10
Setup	5-10
Tuning	5-11
Watch	5-11
Functions	5-11
Terminal	5-11
Windows	5-11
PLC Program	5-12
Section 6	
Troubleshooting	6-1
Section 7	
Specifications & Product Data	7-1
Identification	7-1
Specifications	7-2
24VDC Logic Power Input	7-4
Velocity Control	7-4
Resolver Feedback	7-4
Simulated Encoder Output	7-4
Pulse / Direction Input	7-4
Encoder Input	7-5
Serial Interface	7-5
Optional Interface	7-5
Regeneration	7-5
Dimensions	7-6

Section 8	
CE Guidelines	8-1
CE Declaration of Conformity	8-1
EMC - Conformity and CE - Marking	8-1
EMC Installation Instructions	8-3
Section 9	
Accessories and Options	9-1
Cables	9-1
Connectors	9-1
EMC AC Mains Filter	9-2
Regeneration Resistor	9-4
CAN Bus	9-5
Getting Started with CAN_OPEN	9-7
Identifiers and object list	9-10
Appendix A	
Manual Tuning	A-1
Motor	A-2
Control	A-2
Operating Mode	A-3
Current Parameter	A-4
Velocity Parameter	A-4
Drift	A-5
Manual Tuning	A-5
Plotting of Move	A-9
Pulse Follower Applications	A-10
Appendix B	
Command Set	B-1

Section 1 General Information

Copyright Baldor © 1999, 2000. All rights reserved.

This manual is copyrighted and all rights are reserved. This document may not, in whole or in part, be copied or reproduced in any form without the prior written consent of Baldor.

Baldor makes no representations or warranties with respect to the contents hereof and specifically disclaims any implied warranties of fitness for any particular purpose. The information in this document is subject to change without notice.

Baldor assumes no responsibility for any errors that may appear in this document.

Microsoft and MS-DOS are registered trademarks, and Windows is a trademark of Microsoft Corporation.

UL and cUL are registered trademarks of Underwriters Laboratories.

CE Compliance

A custom unit may be required, contact Baldor. Compliance to Directive 89/336/EEC is the responsibility of the system integrator. A control, motor and all system components must have proper shielding, grounding, and filtering as described in MN1383. Please refer to MN1383 for installation techniques for CE compliance. For additional information, refer to Sections 3 and 8 of this manual.

Limited Warranty

For a period of two (2) years from the date of original purchase, BALDOR will repair or replace without charge controls and accessories which our examination proves to be defective in material or workmanship. This warranty is valid if the unit has not been tampered with by unauthorized persons, misused, abused, or improperly installed and has been used in accordance with the instructions and/or ratings supplied. This warranty is in lieu of any other warranty or guarantee expressed or implied. BALDOR shall not be held responsible for any expense (including installation and removal), inconvenience, or consequential damage, including injury to any person or property caused by items of our manufacture or sale. (Some states do not allow exclusion or limitation of incidental or consequential damages, so the above exclusion may not apply.) In any event, BALDOR's total liability, under all circumstances, shall not exceed the full purchase price of the control. Claims for purchase price refunds, repairs, or replacements must be referred to BALDOR with all pertinent data as to the defect, the date purchased, the task performed by the control, and the problem encountered. No liability is assumed for expendable items such as fuses.

Goods may be returned only with written notification including a BALDOR Return Authorization Number and any return shipments must be prepaid.

Product Notice

Intended use:

These drives are intended for use in stationary ground based applications in industrial power installations according to the standards EN60204 and VDE0160. They are designed for machine applications that require variable speed controlled three phase brushless AC motors.

These drives are not intended for use in applications such as:

- Home appliances
- Medical instrumentation
- Mobile vehicles
- Ships
- Airplanes

Unless otherwise specified, this drive is intended for installation in a suitable enclosure. The enclosure must protect the control from exposure to excessive or corrosive moisture, dust and dirt or abnormal ambient temperatures. The exact operating specifications are found in Section 7 of this manual.

The installation, connection and control of drives is a skilled operation, disassembly or repair must not be attempted.

In the event that a control fails to operate correctly, contact the place of purchase for return instructions.

Safety Notice:

This equipment contains high voltages. Electrical shock can cause serious or fatal injury. Only qualified personnel should attempt the start-up procedure or troubleshoot this equipment.

This equipment may be connected to other machines that have rotating parts or parts that are driven by this equipment. Improper use can cause serious or fatal injury. Only qualified personnel should attempt the start-up procedure or troubleshoot this equipment.

- System documentation must be available at all times.
- Keep non-qualified personnel at a safe distance from this equipment.
- Only qualified personnel familiar with the safe installation, operation and maintenance of this device should attempt start-up or operating procedures.
- Always remove power before making or removing any connections to this control.

PRECAUTIONS: Classifications of cautionary statements.

 **WARNING:** Indicates a potentially hazardous situation which, if not avoided, could result in injury or death.

 **Caution:** Indicates a potentially hazardous situation which, if not avoided, could result in damage to property.

Continued on next page.

-
- ⚠ WARNING:** Do not touch any circuit board, power device or electrical connection before you first ensure that power has been disconnected and there is no high voltage present from this equipment or other equipment to which it is connected. Electrical shock can cause serious or fatal injury.
- ⚠ WARNING:** Be sure that you are completely familiar with the safe operation of this equipment. This equipment may be connected to other machines that have rotating parts or parts that are controlled by this equipment. Improper use can cause serious or fatal injury.
- ⚠ WARNING:** Be sure all wiring complies with the National Electrical Code and all regional and local codes or CE Compliance. Improper wiring may cause a hazardous condition.
- ⚠ WARNING:** Be sure the system is properly grounded before applying power. Do not apply AC power before you ensure that grounds are connected. Electrical shock can cause serious or fatal injury.
- ⚠ WARNING:** Do not remove cover for at least five (5) minutes after AC power is disconnected to allow capacitors to discharge. Electrical shock can cause serious or fatal injury.
- ⚠ WARNING:** Improper operation of control may cause violent motion of the motor shaft and driven equipment. Be certain that unexpected motor shaft movement will not cause injury to personnel or damage to equipment. Peak torque of several times the rated motor torque can occur during control failure.
- ⚠ WARNING:** Motor circuit may have high voltage present whenever AC power is applied, even when motor is not rotating. Electrical shock can cause serious or fatal injury.
- ⚠ WARNING:** If a motor is driven mechanically, it may generate hazardous voltages that are conducted to its power input terminals. The enclosure must be grounded to prevent a possible shock hazard.
- ⚠ WARNING:** When operating a motor with no load coupled to its shaft, remove the shaft key to prevent injury if it were to fly out when the shaft rotates.
- ⚠ WARNING:** The motor shaft will rotate during the autotune procedure. Be certain that unexpected motor shaft movement will not cause injury to personnel or damage to equipment.
- ⚠ WARNING:** A DB Resistor may generate enough heat to ignite combustible materials. To avoid fire hazard, keep all combustible materials and flammable vapors away from brake resistors.
- ⚠ WARNING:** The user must provide an external hard-wired emergency stop circuit to disable the control in the event of an emergency.
- ⚠ Caution:** Suitable for use on a circuit capable of delivering not more than the RMS symmetrical short circuit amperes listed here at rated voltage.
- | <u>Horsepower</u> | <u>RMS Symmetrical Amperes</u> |
|-------------------|--------------------------------|
| 1-50 | 5,000 |
- ⚠ Caution:** To prevent equipment damage, be certain that the input power has correctly sized protective devices installed as well as a power disconnect.

Continued on next page.

-
- ⚠ Caution:** Avoid locating control immediately above or beside heat generating equipment, or directly below water or steam pipes.
- ⚠ Caution:** Avoid locating control in the vicinity of corrosive substances or vapors, metal particles and dust.
- ⚠ Caution:** For UL installations, do not connect any resolver cable shields to the motor frame. At a minimum, resolver signal integrity will be compromised and damage to the control may result. For CE installations, refer to CE guidelines stated in Sections 3 and 8 of this manual.
- ⚠ Caution:** Do not connect AC power to the control terminals U, V and W. Connecting AC power to these terminals may result in damage to the control.
- ⚠ Caution:** Baldor recommends not using “Grounded Leg Delta” transformer power leads that may create ground loops and degrade system performance. Instead, we recommend using a four wire Wye.
- ⚠ Caution:** Logic signals are interruptible signals; these signals are removed when power is removed from the drive.
- ⚠ Caution:** Controls are intended to be connected to a permanent main power source, not a portable power source. Suitable fusing and circuit protection devices are required.
- ⚠ Caution:** The safe integration of the drive into a machine system is the responsibility of the machine designer. Be sure to comply with the local safety requirements at the place where the machine is to be used. In Europe this is the Machinery Directive, the ElectroMagnetic Compatibility Directive and the Low Voltage Directive. In the United States this is the National Electrical code and local codes.
- ⚠ Caution:** Controls must be installed inside an electrical cabinet that provides environmental control and protection. Installation information for the drive is provided in this manual. Motors and controlling devices that connect to the drive should have specifications compatible to the drive.
- ⚠ Caution:** Violent jamming (stopping) of the motor shaft during operation may damage the motor and control.
- ⚠ Caution:** Do not tin (solder) exposed wires. Solder contracts over time and may cause loose connections.
- ⚠ Caution:** Electrical components can be damaged by static electricity. Use ESD (electro-static discharge) procedures when handling this control.
- ⚠ Caution:** Ensure that resolver or encoder wires are properly connected. Incorrect installation may result in improper rotation or incorrect commutation.
- ⚠ Caution:** The holes in the top and bottom of the enclosure are for cable clamps. Be sure to use an M4 bolt 12mm in length. Longer bolts may short circuit the electrical components inside the control.

Section 2

Product Overview

Overview

The *FlexDrive* product is designed to serve the needs of machine designers and manufacturers. Baldor products have both UL and CE approvals. The *FlexDrive* is a “flexible” versatile compact control for brushless servo motors. This digital servo control can be tailored to suit many applications. It can accept 0–10VDC input, standard ± 10 VDC input, current loop input, pulse and direction input or electronic handwheel input.

Some flexible options are CAN bus interface (for resolver feedback only), internal or external regen, or with customer provided 24VDC to maintain logic power.

The *FlexDrive* can be integrated with Baldors’ motion controllers or to any industry standard motion controller.

Motors

Baldor servo controls are compatible with many motors from Baldor and other manufacturers. Motor parameters are provided with the PC software making the setup easy. Baldor compatible motors include:

- BSM–A–Series motors
- BSM–B–Series motors
- BSM–F–Series motors
- BSM–N–Series motors

Refer to the Speed/Torque curves in the BR1202 catalog or contact your local Baldor distributor or sales representative for assistance with motor sizing and compatibility. Custom motors or motors not manufactured by Baldor may be used. Please contact your local Baldor distributor or sales representative for assistance.

Command Source

In the analog mode (current or velocity), the control requires a variable 0–10VDC or ± 10 VDC external analog signal. Suitable sources can be a PLC or motion controller.

Pulse and Direction

In the pulse and direction mode, two opto isolated inputs are provided for pulse input and direction input.

The software identifies the command source: A leads B or Pulse Follower.

Serial Communications Interface

A serial port allows external communication. This means that the *FlexDrive* can interface to a PC (for configuration and control) or to other user-supplied equipment such as:

- Host computers
- PLC’s
- PC’s
- Motion controllers

The serial communication interface supports:

- RS232 and the four wire RS–485 communication standards
- Baud rate: 9600

Control Inputs Opto isolated inputs are single ended, user selectable and active high or low:

Enable	CW Enable
Hold	CCW Enable
Fault Reset	Machine Input 1
Pulse	Machine Input 2
Direction	

Control Outputs

One normally closed relay contact provides a dedicated “Drive Ready” output. Two opto isolated outputs are single ended, active low and are current sinking. Either output can be assigned to one of the following:

In Position	Machine Input 1
CW Warning	Machine Input 2
CCW Warning	I ² t Warning
Following Error Flag	Drive Over Temperature
Following Error Warning	

Simulated Encoder Output

Resolver Feedback

The resolver feedback signal is converted to PPR (pulses per revolution) by a Resolver to Digital Converter. A position controller uses position feedback

The resolution of the simulated encoder output is software controlled with the following available resolutions:

512 PPR, 1024 PPR, 2048 PPR or 4096 PPR

Note: For speeds above 6000 RPM, resolution is limited to 1024PPR maximum.

Encoder Feedback

When encoder feedback is used, the encoder input signal is buffered and provided at the simulated encoder output.

Section 3

Receiving and Installation

Receiving & Inspection Baldor Controls are thoroughly tested at the factory and carefully packaged for shipment. When you receive your control, there are several things you should do immediately.

1. Observe the condition of the shipping container and report any damage immediately to the commercial carrier that delivered your control.
2. Remove the control from the shipping container and remove all packing materials. The container and packing materials may be retained for future shipment.
3. Verify that the part number of the control you received is the same as the part number listed on your purchase order.
4. Inspect the control for external physical damage that may have been sustained during shipment and report any damage immediately to the commercial carrier that delivered your control.
5. If the control is to be stored for several weeks before use, be sure that it is stored in a location that conforms to published storage humidity and temperature specifications stated in this manual.

Location Considerations The location of the control is important. Installation should be in an area that is protected from direct sunlight, corrosives, harmful gases or liquids, dust, metallic particles, and vibration. Exposure to these can reduce the operating life and degrade performance of the control.

Several other factors should be carefully evaluated when selecting a location for installation:

1. For effective cooling and maintenance, the control should be mounted on a smooth, non-flammable vertical surface.
2. At least 0.6 inches (15mm) top and bottom clearance must be provided for air flow. At least 0.4 inches (10mm) clearance is required between controls (each side).
3. **Altitude derating.** Up to 3300 feet (1000 meters) no derating required. Derate the continuous and peak output current by 1.1% for each 330 feet (100 meters) above 3300 feet.
4. **Temperature derating.** From 0°C to 40°C ambient no derating required. Above 40°C, derate the continuous and peak output current by 2.5% per °C above 40°C. Maximum ambient is 50°C.
5. The control must be installed where the pollution degree according to IEC664 shall not exceed 2.

Mechanical Installation

Mount the control to the mounting surface. The control must be securely fastened to the mounting surface by the control mounting holes. The location of the mounting holes is shown in Section 7 of this manual.

Electrical Installation All interconnection wires between the control, AC power source, motor, host control and any operator interface stations should be in metal conduits. Use listed closed loop connectors that are of appropriate size for wire gauge being used. Connectors are to be installed using crimp tool specified by the manufacturer of the connector. Only class 1 wiring should be used.

System Grounding Baldor controls are designed to be powered from standard single and three phase lines that are electrically symmetrical with respect to ground. System grounding is an important step in the overall installation to prevent problems. The recommended grounding method is shown in Figure 3-1 and 3-3 for UL compliant systems (Figure 3-2 and 3-4 for CE compliant systems).

Figure 3-1 Recommended System Grounding (3 phase) for UL

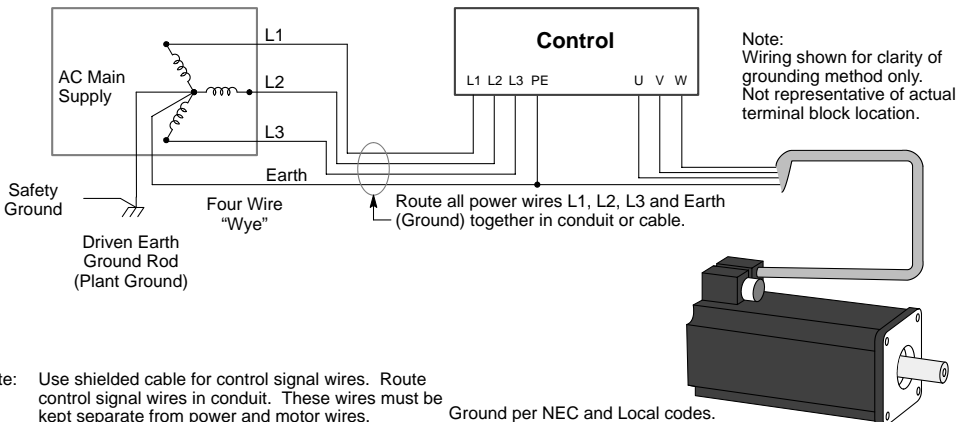

Figure 3-2 Recommended System Grounding (3 phase) for CE

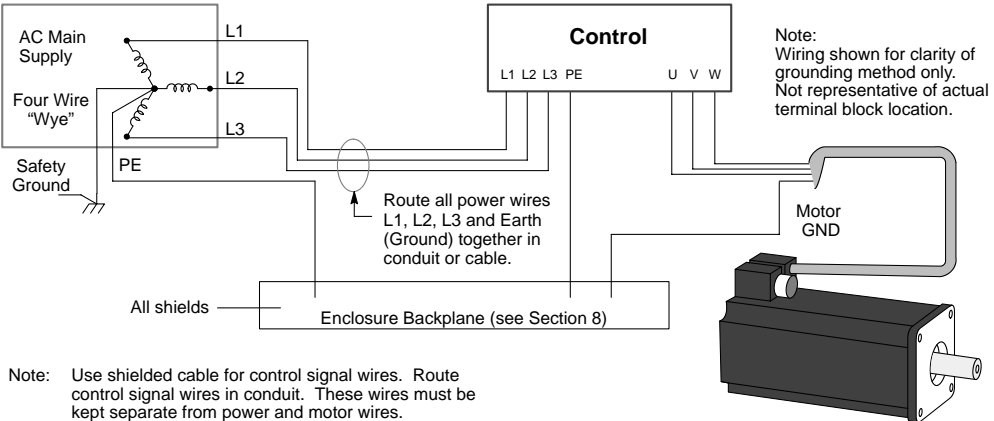
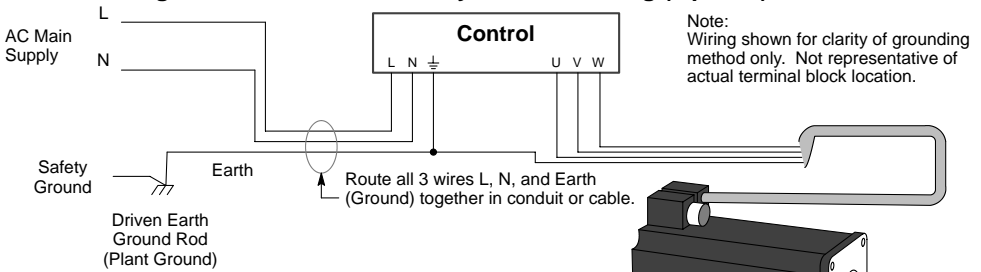

Figure 3-3 Recommended System Grounding (1 phase) for UL



Note: Use shielded cable for control signal wires. Route control signal wires in conduit. These wires must be kept separate from power and motor wires.

Ground per NEC and Local codes.

Figure 3-4 Recommended System Grounding (1 phase) for CE

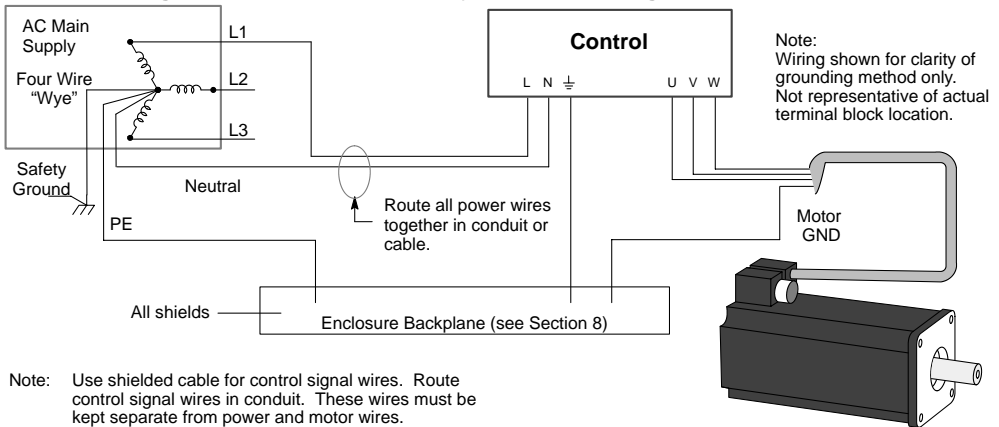

Note: Use shielded cable for control signal wires. Route control signal wires in conduit. These wires must be kept separate from power and motor wires.

System Grounding Continued

Ungrounded Distribution System

With an ungrounded power distribution system it is possible to have a continuous current path to ground through the MOV devices. To avoid equipment damage, an isolation transformer with a grounded secondary is recommended. This provides three phase AC power that is symmetrical with respect to ground.

Input Power Conditioning

Baldor controls are designed for direct connection to standard single and three phase lines that are electrically symmetrical with respect to ground. Certain power line conditions must be avoided. An AC line reactor or an isolation transformer may be required for some power conditions.

- If the feeder or branch circuit that provides power to the control has permanently connected power factor correction capacitors, an input AC line reactor or an isolation transformer must be connected between the power factor correction capacitors and the control.
- If the feeder or branch circuit that provides power to the control has power factor correction capacitors that are switched on line and off line, the capacitors must not be switched while the control is connected to the AC power line. If the capacitors are switched on line while the control is still connected to the AC power line, additional protection is required. TVSS (Transient Voltage Surge Suppressor) of the proper rating must be installed between the AC line reactor or an isolation transformer and the AC input to the control.

Power Disconnect A power disconnect should be installed between the input power service and the control for a fail-safe method to disconnect power. The control will remain in a powered-up condition until all input power is removed from the control and the internal bus voltage is depleted.

Protection Devices The control must have a suitable input power protection device installed. Input and output wire size is based on the use of copper conductor wire rated at 75 °C. Table 3-1 and 3-2 describes the wire size to be used for power connections and the ratings of the protection devices. Use the recommended circuit breaker or fuse types as follows:

- Circuit Breaker: 1 phase, thermal magnetic.
 Equal to GE type THQ or TEB for 115 or 230 VAC
 3 phase, thermal magnetic.
 Equal to GE type THQ or TEB for 230 VAC or
 GE type TED for 460 VAC.
- Time Delay Fuses: Buss FRN on 230 VAC or
 Buss FRS on 460 VAC or equivalent.

Recommended fuse sizes are based on the following:

UL 508C suggests a fuse size of four times the continuous output current of the control.

Dual element, time delay fuses should be used to avoid nuisance trips due to inrush current when power is first applied.

For European installations, you may want to consider the following fast acting fuse: Gould Shawmut Cat. No. ATMR15 for up to 15 amperes.

Table 3-1 Wire Size and Protection Devices (for units with Power Supply)

Catalog Number	Incoming Power					Wire Gauge	
	Nominal Input Voltage	Continuous Output Amps (RMS)	Input Breaker (A)	Input Fuse Time Delay (A)	AWG (USA)	mm ² (Europe)	
FD1A02SR-XXXX	115V (1φ)	2.0A	7.5	8	14	2.5	
FD2A02SR-XXXX	230V (3φ)	2.5A	7	4.5	14	2.5	
FD1A02TR-XXXX	115V (1φ)	2.0A	7.5	8	14	2.5	
FD2A02TR-XXXX	230V (1φ)	2.5A	5	4.5	14	2.5	
FD4A02TB-XXXX	400/460V (3φ)	2.5A	7	4	14	2.5	
FD1A05SR-XXXX	115V (1φ)	5A	7.5	8	14	2.5	
FD1A05SR-XXXX	230V (3φ)	5A	7	8	14	2.5	
FD1A05TR-XXXX	115V (1φ)	5A	7.5	8	14	2.5	
FD2A05TR-XXXX	230V (1φ)	5A	7.5	7	14	2.5	
FD4A05TB-XXXX	400/460V (3φ)	5A	7	7.5	14	2.5	
FD1A07TR-XXXX	115V (1φ)	7.5A	10	10	14	2.5	
FD2A07TR-XXXX	230V (1φ)	7.5A	10	10	14	2.5	
FD4A07TR-XXXX	400/460V (3φ)	7.5A	15	12	14	2.5	
FD1A10SR-XXXX	115V (1φ)	10A	12.5	15	14	2.5	
FD2A10SR-XXXX	230V (3φ)	10A	15	15	14	2.5	
FD1A15SR-XXXX	115V (1φ)	15A	20	20	12	2.5	
FD2A15SR-XXXX	230V (3φ)	15A	20	25	12	2.5	
FD4A15TR-XXXX	400/460V (3φ)	15A	20	20	12	2.5	
FD4A20TR-XXXX	400/460V (3φ)	20A	30	35	10	5.26	
FD4A27TR-XXXX	400/460V (3φ)	27.5A	40	45	10	5.26	

Table 3-2 Wire Size (for units without Power Supply)

Catalog Number	Bus Voltage	Continuous Output Amps	Wire Gauge	
			AWG (USA)	mm ² (Europe)
FD1A02PO-XXXX	160VDC	2.0A	14	2.5
FD2A02PO-XXXX	300VDC	2.5A	14	2.5
FD1A05PO-XXXX	160VDC	5.0A	14	2.5
FD2A05PO-XXXX	300VDC	5.0A	14	2.5
FD1A10PO-XXXX	160VDC	10.0A	12	2.5
FD2A10PO-XXXX	300VDC	10.0A	12	2.5
FD1A15PO-XXXX	160VDC	15.0A	10	2.5
FD2A15PO-XXXX	300VDC	15.0A	10	2.5

Note: All wire sizes are based on 75°C copper wire. Higher temperature smaller gauge wire may be used per NEC and local codes. Recommended fuses/breakers are based on 25°C ambient, maximum continuous control output current and no harmonic current.

X1 Power Connections

Power connections are shown in Figures 3-5 through 3-8.

Figure 3-5 Single Phase AC Power Connections (FD1AxxT & FD2AxxT only)

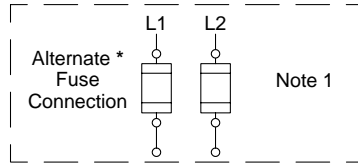
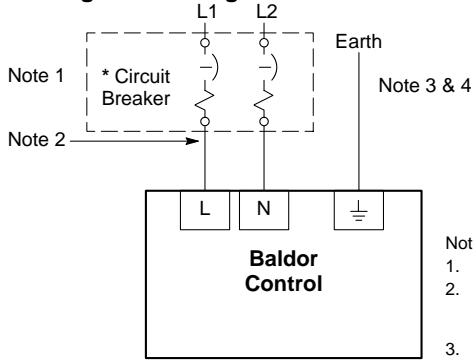

* Components not provided with Control.

Notes:

1. See "Protection Devices" described in this section.
2. Metal conduit or shielded cable should be used. Connect conduits so the use of a Reactor or RC Device does not interrupt EMI/RFI shielding.
3. Use same gauge wire for Earth ground as is used for L and N. (VDE (Germany) requires 10mm² minimum). For CE Compliance, connect \perp to the backplane of the enclosure.
4. Reference EMC wiring in Section 8.

For CE Compliance, refer to Section 8 of this manual.

Figure 3-6 Single Phase AC Power Connections (FD1AxxS only)

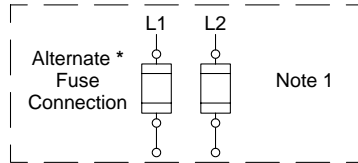
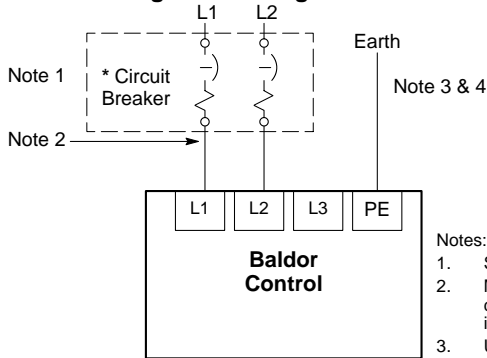

* Components not provided with Control.

Notes:

1. See "Protection Devices" described in this section.
2. Metal conduit or shielded cable should be used. Connect conduits so the use of a Reactor or RC Device does not interrupt EMI/RFI shielding.
3. Use same gauge wire for Earth ground as is used for L and N. (VDE (Germany) requires 10mm² minimum). For CE Compliance, connect \perp to the backplane of the enclosure.
4. Reference EMC wiring in Section 8.

For CE Compliance, refer to Section 8 of this manual.

Note: These FlexDrive versions are not designed for use with 400/460VAC connections.

Figure 3-7 3 Phase Power Connections (FD2AxxS & FD4AxxT only)

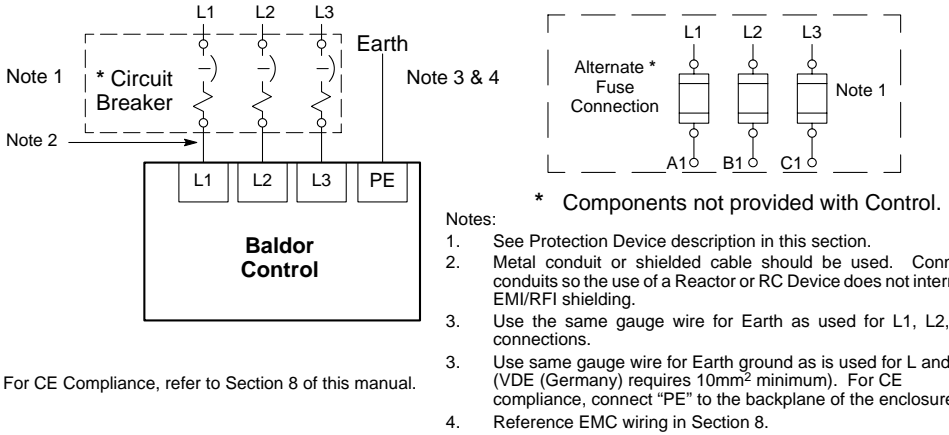

A shared supply configuration is shown in Figure 3-8. The first drive must have an internal power supply such as an Option "S" control.

Figure 3-8 Shared Supply Power Connections

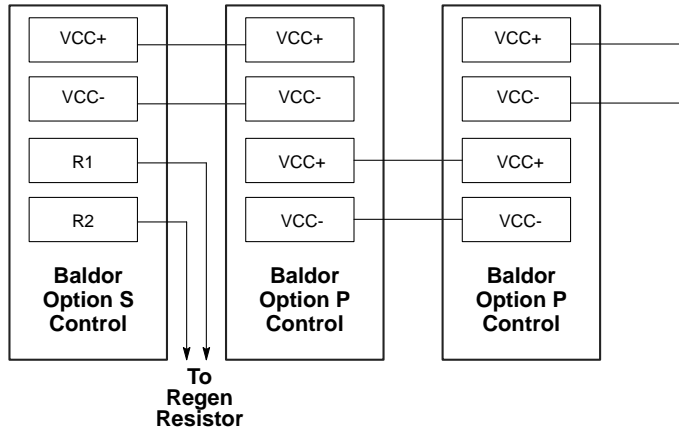

Figure 3-9 Connector Locations (Single Phase Controls)

- X1 - Power Connector**
- | | | |
|------|-------------------|----------------------------------|
| ⊕ | Earth | } Input Power |
| L | AC Line | |
| N | Neutral | } Motor |
| U | Motor lead "U" | |
| V | Motor lead "V" | |
| W | Motor lead "W" | |
| R1 | Dynamic Brake | } Dynamic Brake (Regen Resistor) |
| R2 | Dynamic Brake | |
| +24V | Customer Provided | } FDxAxxxx-xxx3 only □ |
| 0V | | |

Terminal tightening torque is 0.5 lb-in (0.6Nm)

X3 - Control Signals & Digital I/O

- 1 CMD+
- 2 CMD-
- 3 AGND
- 4 Fault Relay+
- 5 Fault Relay-
- 6 CIV
- 7 CREF
- 8 CGND
- 9 Enable
- 10 CW - Enable
- 11 CCW - Enable
- 12 Hold
- 13 Fault Reset
- 14 Pulse
- 15 Direction
- 16 Ma1
- 17 Ma2
- 18 MaO1
- 19 MaO2
- 20 DrOK

□ Important:

FDxAxxxx-xxx3 only.
A separate 24VDC supply to the "Logic Power" input is required for operation. An FDxAxxxx-xxx3 control will not operate without 24VDC on this input.

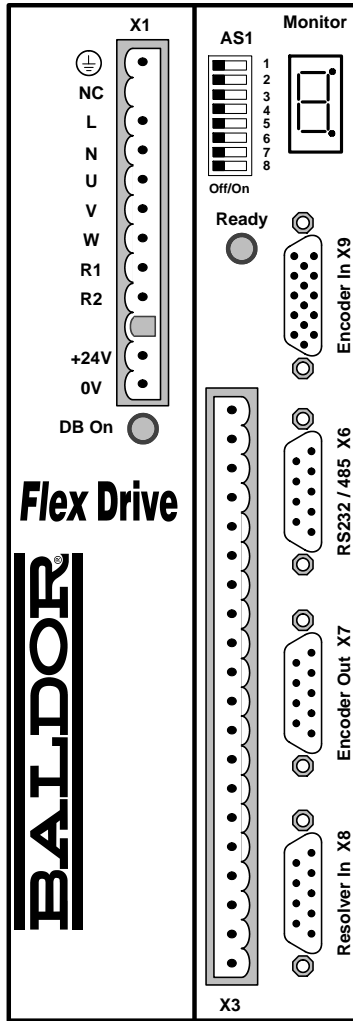

The holes in the top and bottom of the enclosure are for cable clamps. Be sure to use an M4 bolt 12mm in length. Longer bolts may short circuit the electrical components inside the control.

X9 - Handwheel Input (Encoder)

- | | |
|-----------|------------|
| 1 CHA+ | 9 Hall 3+ |
| 2 CHB+ | 10 Hall 2+ |
| 3 CHC+ | 11 +5VDC |
| 4 Hall 1+ | 12 N.C. |
| 5 Hall 1- | 13 DGND |
| 6 CHA- | 14 Hall 3- |
| 7 CHB- | 15 Hall 2- |
| 8 CHC- | |

X6 - RS232 / 485

- | RS232 | | RS485 | |
|-----------------------|--------|-------|--|
| 1 Reserved | 1 TX- | | |
| 2 R _x Data | 2 TX+ | | |
| 3 T _x Data | 3 RX+ | | |
| 4 DTR | 4 RX- | | |
| 5 DGND | 5 DGND | | |
| 6 DSR | 6 RTS- | | |
| 7 RTS | 7 RTS+ | | |
| 8 CTS | 8 CTS+ | | |
| 9 +5V | 9 CTS- | | |

X7 - Simulated Encoder Output

- | | |
|------------|------------|
| 1 CHA+ | 6 CHA- |
| 2 CHB+ | 7 CHB- |
| 3 CHC+ | 8 CHC- |
| 4 Reserved | 9 Reserved |
| 5 DGND | |

X8 - Resolver Input

- | | |
|------------|------------|
| 1 REF+ | 6 REF- |
| 2 COS+ | 7 COS- |
| 3 SIN+ | 8 SIN- |
| 4 Reserved | 9 Reserved |
| 5 AGND | |

Note: Reserved means no connection is required and no connection should be made to this terminal. It is reserved for future use.

Figure 3-10 Connector Locations (Three Phase Controls)

- X1 - Power Connector**
- | | | |
|------|----------------|---|
| PE | Earth | } Input Power |
| L1 | Phase 1 Input | |
| L2 | Phase 2 Input | |
| L3 | Phase 3 Input | } Motor |
| U | Motor lead "U" | |
| V | Motor lead "V" | |
| W | Motor lead "W" | } Dynamic Brake
(Regen Resistor) |
| R1 | Dynamic Brake | |
| R2 | Dynamic Brake | |
| +24V | Customer | } FDxAxxxx-xxx3 only  |
| 0V | Provided | |

Terminal tightening torque is
0.5 lb-in (0.6Nm)

X3 - Control Signals & Digital I/O

- | | |
|----|--------------|
| 1 | CMD+ |
| 2 | CMD- |
| 3 | AGND |
| 4 | Fault Relay+ |
| 5 | Fault Relay- |
| 6 | CIV |
| 7 | CREF |
| 8 | CGND |
| 9 | Enable |
| 10 | CW - Enable |
| 11 | CCW - Enable |
| 12 | Hold |
| 13 | Fault Reset |
| 14 | Pulse) |
| 15 | Direction |
| 16 | Ma1 |
| 17 | Ma2 |
| 18 | MaO1 |
| 19 | MaO2 |
| 20 | DrOK |

 **Important:**
FDxAxxxx-xxx3 only.

A separate 24VDC supply to the "Logic Power" input is required for operation. An FDxAxxxx-xxx3 control will not operate without 24VDC on this input.

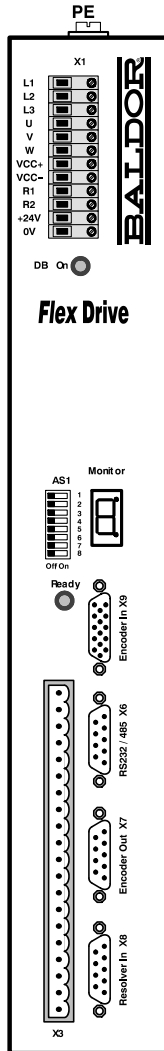

The holes in the top and bottom of the enclosure are for cable clamps. Be sure to use an M4 bolt 12mm in length. Longer bolts may short circuit the electrical components inside the control.

X9 - Handwheel Input (Encoder)

- | | | | |
|---|---------|----|---------|
| 1 | CHA+ | 9 | Hall 3+ |
| 2 | CHB+ | 10 | Hall 2+ |
| 3 | CHC+ | 11 | +5VDC |
| 4 | Hall 1+ | 12 | N.C. |
| 5 | Hall 1- | 13 | DGND |
| 6 | CHA- | 14 | Hall 3- |
| 7 | CHB- | 15 | Hall 2- |
| 8 | CHC- | | |

X6 - RS232 / 485

- | <u>RS232</u> | | <u>RS485</u> | |
|--------------|---------------------|--------------|------|
| 1 | Reserved | 1 | TX- |
| 2 | R _x Data | 2 | TX+ |
| 3 | T _x Data | 3 | RX+ |
| 4 | DTR | 4 | RX- |
| 5 | DGND | 5 | DGND |
| 6 | DSR | 6 | RTS- |
| 7 | RTS | 7 | RTS+ |
| 8 | CTS | 8 | CTS+ |
| 9 | +5V | 9 | CTS- |

X7 - Simulated Encoder Output

- | | | | |
|---|----------|---|----------|
| 1 | CHA+ | 6 | CHA- |
| 2 | CHB+ | 7 | CHB- |
| 3 | CHC+ | 8 | CHC- |
| 4 | Reserved | 9 | Reserved |
| 5 | DGND | | |

X8 - Resolver Input

- | | | | |
|---|----------|---|----------|
| 1 | REF+ | 6 | REF- |
| 2 | COS+ | 7 | COS- |
| 3 | SIN+ | 8 | SIN- |
| 4 | Reserved | 9 | Reserved |
| 5 | AGND | | |

Note: Reserved means no connection is required and no connection should be made to this terminal. It is reserved for future use.

X1 Motor Connections

Motor connections are shown in Figure 3-11. It is important to connect the motor leads U, V and W correctly at the X1 connector of the control. Incorrect wiring can cause erratic operation including moves at peak force until the overcurrent limit trips. This will result in a display of "7" and a "6" on the monitor. If erratic movement of the motor occurs, turn off power immediately and check the connections of the motor, hall sensors and encoder.

Figure 3-11 Motor Connections for U.L.

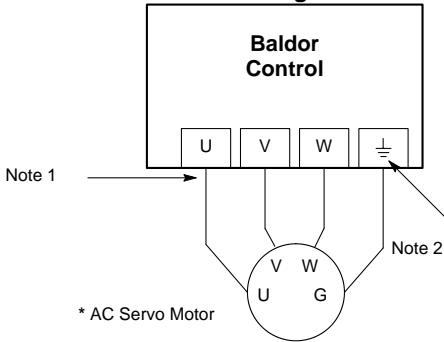

Notes:

1. Metal conduit or shielded cable should be used. Connect conduits so the use of Load Reactor* or RC Device* does not interrupt EMI/RFI shielding.
2. Use same gauge wire for Earth ground as is used for L and N. (VDE (Germany) requires 10mm² minimum, 6AWG). For CE compliance, connect motor ground to the backplane of the enclosure.
3. Reference EMC wiring in Section 8.
4. Motor and resolver are phase sensitive. Connect only as instructed.

For three phase controls, this is labeled "PE".

* Optional components not provided with control.

Figure 3-12 Motor Connections for CE

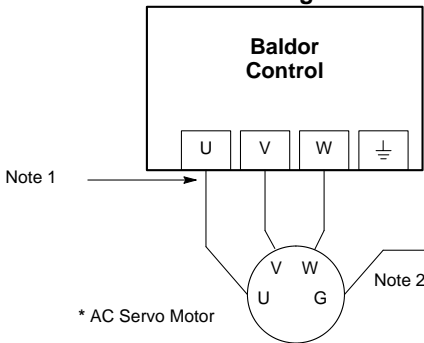

Notes:

1. Metal conduit or shielded cable should be used. Connect conduits so the use of Load Reactor* or RC Device* does not interrupt EMI/RFI shielding.
2. Use same gauge wire for Earth ground as is used for L and N. (VDE (Germany) requires 10mm² minimum, 6AWG). For CE compliance, connect motor ground to the backplane of the enclosure.
3. Reference EMC wiring in Section 8.
4. Motor and encoder are phase sensitive. Connect only as instructed.

Enclosure Backplane (see Section 8)

* Optional components not provided with control.

Note: For CE compliant installations, connect unused leads within the motor cable to "PE" on both ends of the cable.

M-Contactor

If required by local codes or for safety reasons, an M-Contactor (motor circuit contactor) may be installed. However, incorrect installation or failure of the M-contactor or wiring may damage the control. If an M-Contactor is installed, the control must be disabled for at least 20msec before the M-Contactor is opened or the control may be damaged. M-Contactor connections are shown in Figure 3-13.

Figure 3-13 Optional M-Contactor Connections

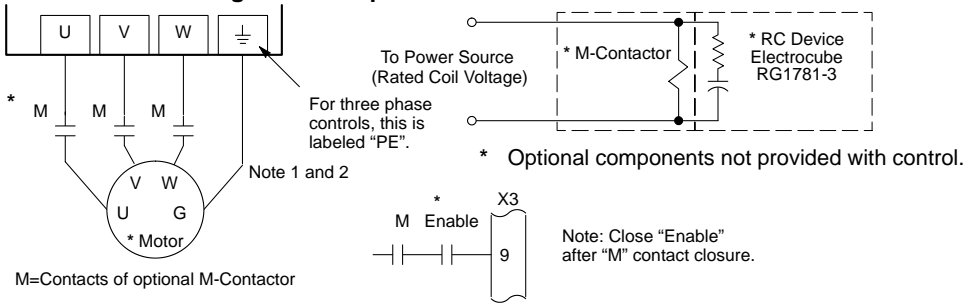

Motor Thermostat

A relay contact can be used to isolate the motor thermostat leads for use with other devices, shown in Figure 3-14. The thermostat or overload relay should be a dry contact type with no power available from the contact. The optional relay (CR1) shown provides the isolation required and the N.O. contact is open when power is applied to the relay and the motor is cold. If the motor thermostat is tripped, CR1 is de-energized and the N.O. contact closes.

Connect the External Trip Input wires (N.O. relay contact) to a PLC or other device. Note that a machine input may be used and the PLC software of the FlexDrive can define the thermal protection. Do not place these wires in the same conduit as the motor power leads.

Figure 3-14 Motor Temperature Relay

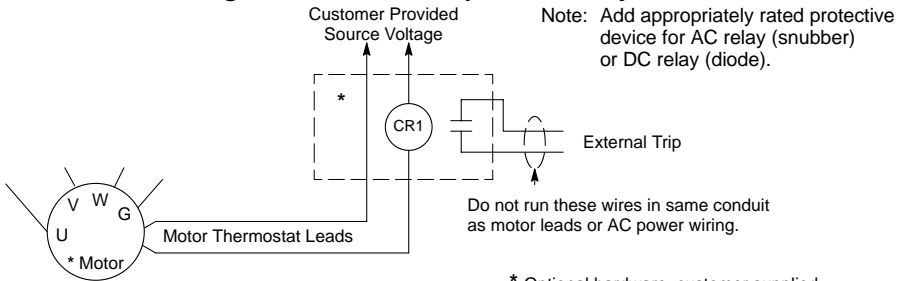

* Optional hardware, customer supplied.

X1 Dynamic Brake Resistor An external DB (dynamic brake or regen resistor) resistor may be required to dissipate excess power from the DC bus during motor deceleration operations. Some controls have an internal resistor. For selection of the DB resistor, refer to the specifications located in Section 7 and the regeneration resistor specifications in Section 9 of this manual. DB hardware is connected at R1 and R2 terminals of the X1 connector, Figure 3-9 and 3-10.

X1 +24VDC Logic Supply For FDxAxxxx-xxx3 only. A separate 24VDC supply to the "Logic Power" input is required for operation. An external 24 VDC power source must be used. If bus power is lost, the logic circuits are still active if the 24VDC is present. This is important to maintain position reference, for example.

If the control was not ordered with this option, do not connect any voltage to these pins.

X3 Control Inputs & Digital I/O Connections

Control Inputs X3 pins 1 and 2 allows connection of an external analog command input. This input can accept a 0-10VDC or ± 10 VDC signal and can be wired as a single ended or differential input, shown in Figure 3-15.

Figure 3-15 Control Input Wiring

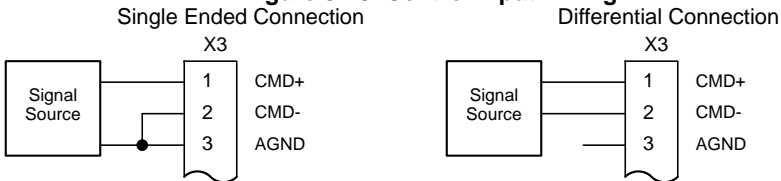

X3 Digital Inputs - Opto Isolated Inputs (uses CREF, X3-7)

- Active High (Sourcing) -** If pin X3-7 is grounded, an input is active when it is at +24VDC (+12VDC to +30VDC).
- Active Low (Sinking) -** If pin X3-7 is at +24VDC (+12VDC to +30VDC), an input is active when it is grounded.

Logic input connections are made at terminal strip X3. Input connections can be wired as active High or active Low as shown in Figure 3-16. X3 pin 7 is the Control Reference point (CREF) for the Opto Isolated Input signals.

Note: An internal 24VDC power supply connection is not available from the control to power the Opto Input circuits. A customer provided external power source must be used as indicated in Figure 3-16.

Figure 3-16 Active HIGH /LOW Relationship

Active Low (Sink)	Active High (Source)	Input
+24VDC	GND	A
GND	+24VDC	B

Note: All Opto inputs are referenced to CREF, X3-7.

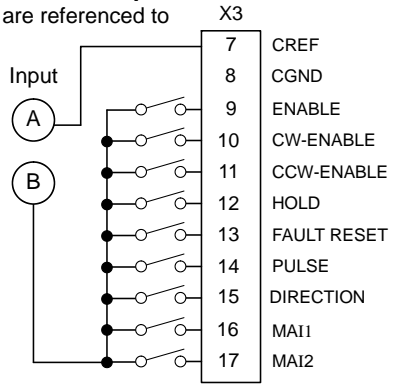
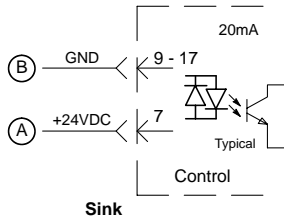
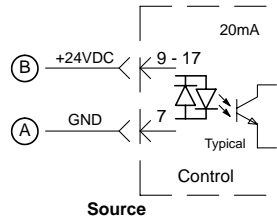

X3 Digital Inputs Continued

Table 3-3 Opto Input Signal Conditions

Pin Number	Signal Name	Switch = Closed (active)	Switch = Open (not active)
X3-9	Enable	Drive enabled.	Drive disabled.
X3-10	CW-Enable	Clockwise rotation enabled.	Clockwise rotation disabled.
X3-11	CCW-Enable	Counter-clockwise rotation enabled.	Counter-clockwise rotation disabled.
X3-12	Hold	HOLD function is active.	HOLD function is not active.
X3-13	Fault Reset	Fault Reset is active (reset control).	Fault Reset is not active.
X3-14	Pulse	See Pulse & Direction Definition.	See Pulse & Direction Definition.
X3-15	Direction	See Pulse & Direction Definition.	See Pulse & Direction Definition.
X3-16	Ma1	Machine Input 1 = Logical 1	Machine Input 1 = Logical 0
X3-17	Ma2	Machine Input 2 = Logical 1	Machine Input 2 = Logical 0

Signal Name Opto Input Signal Definition

- Enable** CLOSED allows normal operation.
OPEN disables the control and motor coasts to a stop.
- CW-Enable** CLOSED allows normal operation in the CW direction.
OPEN to disable CW rotation. The motor decels to a stop.
- CCW-Enable** CLOSED allows normal operation in the CCW direction.
OPEN to disable CCW rotation. The motor decels to a stop.
- Hold** CLOSED causes the motor to decelerate (at maximum deceleration rate) to rest and maintain a constant position (to prevent drift in velocity mode only).
OPEN allows normal operation.
- Fault Reset** CLOSED allows the control to be cleared or "Reset" for any of the following four fault conditions (provided that the cause of the fault has been removed):
- Overvoltage
 - Electronic Fusing
 - Undervoltage
 - Resolver Fault
- OPEN allows normal operation.

Pulse & Direction

The pulse and direction inputs allow the control to change speed and direction based on these signals. The frequency of the signal at the pulse input determines the motor velocity. The logic state of the signal applied at the direction input determines the direction of rotation (CW = 1; CCW = 0). The input voltage for both pulse and direction is 12 - 29VDC at 20mA.

Figure 3-17 Pulse & Direction Timing Diagram

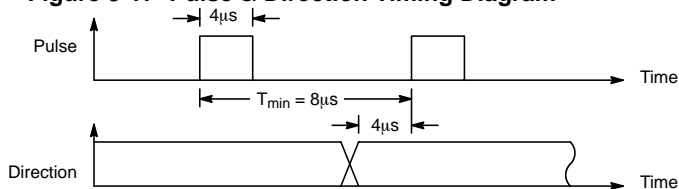

X3 Digital Inputs Continued

MaI1 & 2 Two machine inputs are provided. These inputs are used with the internal PLC software program. The internal PLC software can cause an event to occur based on the presence of one or both inputs.

X3 Digital Outputs - Opto Isolated Outputs

The control outputs are located on the X3 connector. A customer provided, external power supply must be used if digital outputs are to be used. The opto outputs provide status information and are not required for operation, Table 3-4.

Figure 3-18 Fault Relay Connections

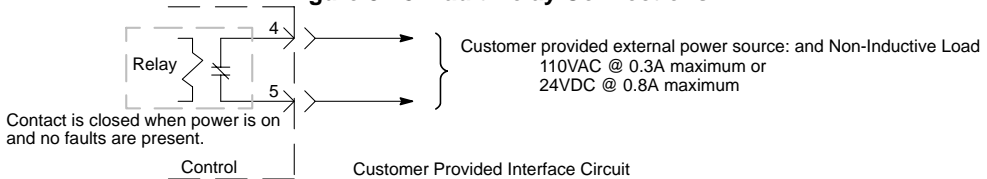

Figure 3-19 Opto Output Connections

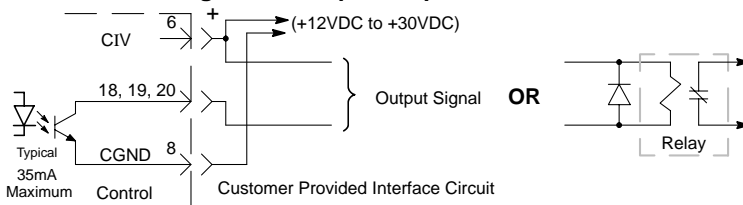

Table 3-4 Opto Output Signal Conditions

Pin Number	Signal Name	Switch = Closed (active)	Switch = Open (not active)
X3-4	Fault +	Drive OK - no faults detected	Fault is detected
X3-5	Fault -	Drive OK - no faults detected	Fault is detected
X3-18	MAO1	Machine Output 1 = Logical 1	Machine Output 1 = Logical 0
X3-19	MAO2	Machine Output 2 = Logical 1	Machine Output 2 = Logical 0
X3-20	DrOK	Drive OK - no faults detected	Fault is detected

Fault Relay A normally closed relay contact that opens if a fault occurs. The contact is rated: 24VDC @ 0.8A maximum or 110VAC @ 0.3A maximum.

MaO1 & 2 Two machine outputs are provided. Either output can be set to one of the following conditions: CW Warning, CCW Warning, In Position, Error Flag, Following Error Warning, MAI1-2, Drive Overtemperature or I²T Warning. Each output is rated 30VDC @ 35mA maximum.

DrOK This output is active when the control is ready for operation. This output is rated 30VDC @ 35mA maximum.

X6 RS232 / 485 Connections

RS232

A null modem cable (also called a modem eliminator cable) must be used to connect the control and the computer COM port. This will ensure that the transmit and receive lines are properly connected. Either a 9 pin or a 25 pin connector can be used at the computer, Figure 3-20. Maximum recommended length for RS232 cable is 3 ft. (1 meter).

Figure 3-20 9 & 25 Pin RS-232 Cable Connections for UL Installations

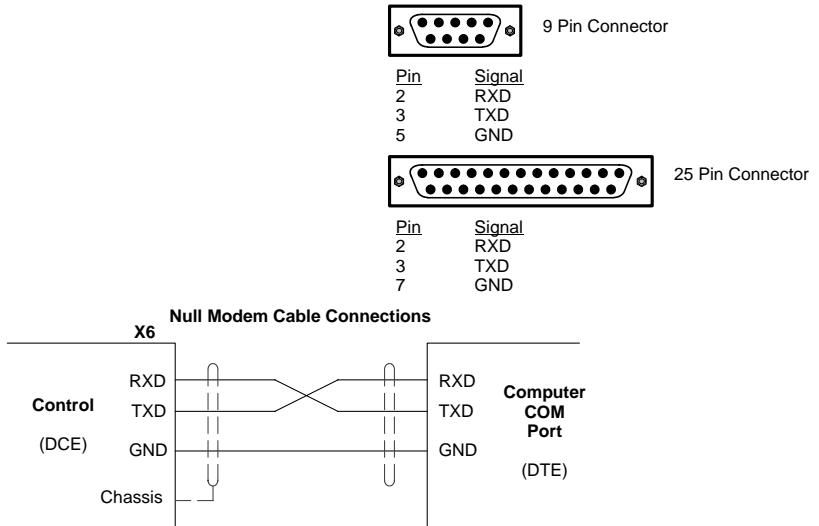
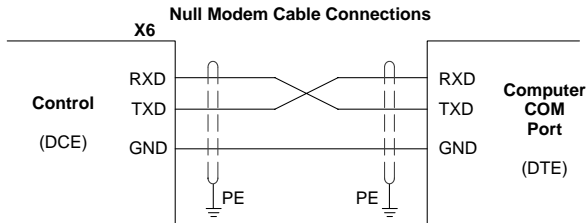

Figure 3-21 9 & 25 Pin RS-232 Cable Connections for CE Installations



Note: For CE installations, connect the overall shield at each end of the cable to PE. The voltage potential between the PE points at each end of the cable must be Zero Volts.

RS485

Standard RS485 connections are shown in Figure 3-23. Maximum cable length is 3280 ft (1000M).

Figure 3-22 9 Pin RS-485 Cable Connections For UL Installations

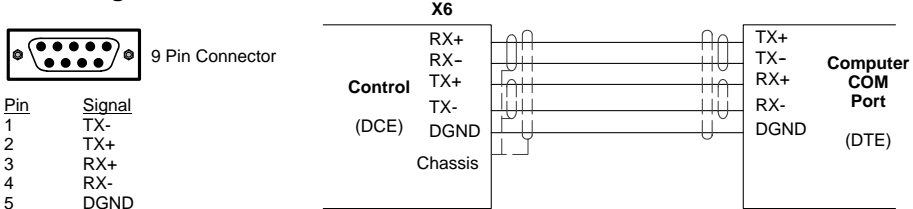
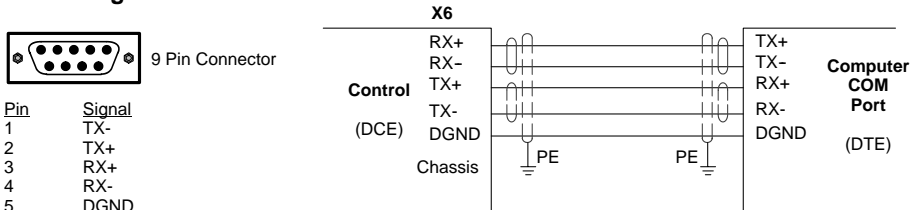

Figure 3-23 9 Pin RS-485 Cable Connections For CE Installations



Note: For CE installations, connect the overall shield at each end of the cable to PE. The voltage potential between the PE points at each end of the cable must be Zero Volts.

RS485 Multi-Drop Connections

What does termination or a termination resistor do?

Termination resistance is used to match the impedance of the load to the impedance of the transmission line (cable) being used. Unmatched impedance causes the transmitted signal to not be fully absorbed by the load. This causes a portion of the signal to be reflected back into the transmission line (noise). If the *Source* impedance, *Transmission Line* impedance, and *Load* impedance are all equal, these reflections (noise) are eliminated.

Termination does increase load current and sometimes changes the bias requirements and increases the complexity of the system.

What is a termination resistor?

A resistor is added in parallel with the receiver input to match the impedance of the cable being used. Typically, the resistor value that is used is 100 ohm or 120 ohm. Resistors with 90 ohms or less should never be used.

Where are these resistors placed?

Terminators or Termination resistors are placed in parallel with the receiver at both ends of a transmission line. This means that you should **never** have more than two terminators in the system (unless repeaters are being used).

How many resistors should my system have?

Terminators or Termination resistors are placed in parallel with the receiver at both ends of a transmission line. This means that you should **never** have more than two terminators in the system (unless repeaters are being used).

Figure 3-24 RS485 4 Wire Multi-Drop for UL Installations

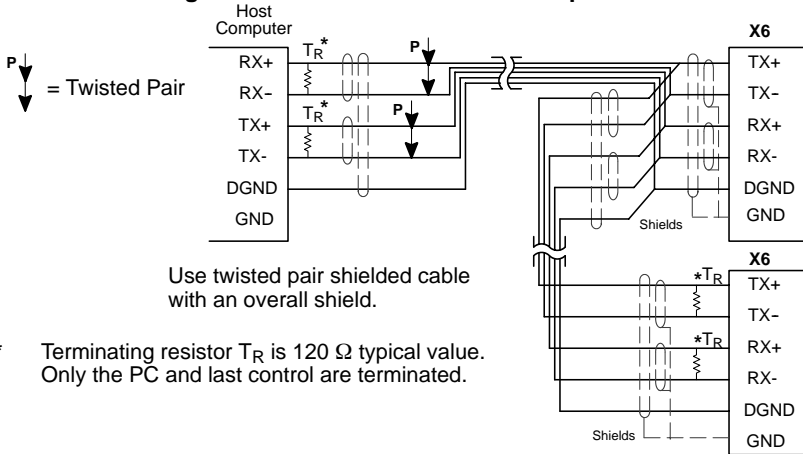
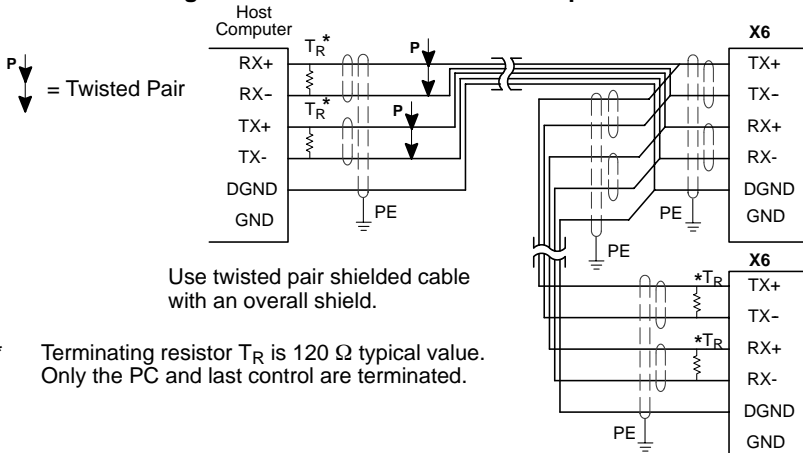

Figure 3-25 RS485 4 Wire Multi-Drop for CE Installations



Note: For CE installations, connect the overall shield at each end of the cable to PE. The voltage potential between the PE points at each end of the cable must be Zero Volts.

See Section 4 of this manual for the description of switch "AS1-1 to AS1-4" for address settings for multi-drop applications.

X7 Simulated Encoder Output

The control provides a simulated encoder output at connector X7. This output may be used by external hardware to monitor the encoder signals. It is recommended that this output only drive one circuit load (RS422 interface - 28LS31 device). Refer to Table 3-5. The simulated Encoder Output is set by software control in "General Motor & Control".

Table 3-5 Simulated Encoder Output at X7 Connector

X7 Pin	Signal Name
1	A+
2	B+
3	C+
4	Reserved
5	DGND
6	A-
7	B-
8	C-
9	Reserved
Shell	* Chassis (Cable Shield)

* For UL Installations ONLY. For CE Installations, connect the outer shield on each end of the cable to the enclosure backplane "PE".

X8 Resolver Feedback The resolver connections are the standard feedback on Flex drives and connections are made at the X8 connector as shown in Figure 3-26. The resolver cable must be shielded twisted pair #22 AWG (0.34mm²) wire minimum. The cable must also have an overall shield. Maximum wire-to-wire or wire-to-shield capacitance is 50pf per foot.

Resolver wiring must be separated from power wiring. Separate parallel runs of resolver and power cables by at least 3". Cross power wires at right angles only. Insulate or tape ungrounded end of shields to prevent contact with other conductors or ground.

Note: Motor and resolver are phase sensitive. Connect only as instructed.

Figure 3-26 Resolver Cable Connections for UL Installations

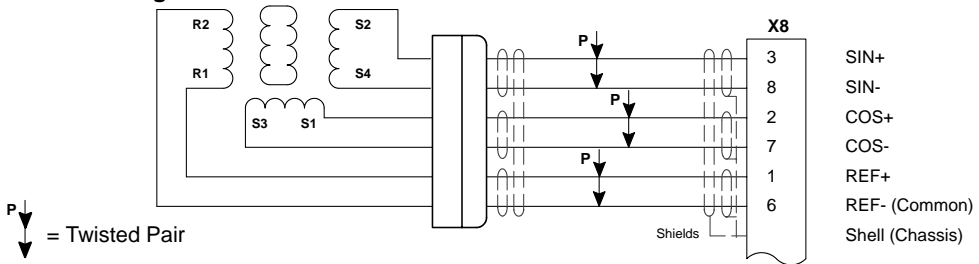
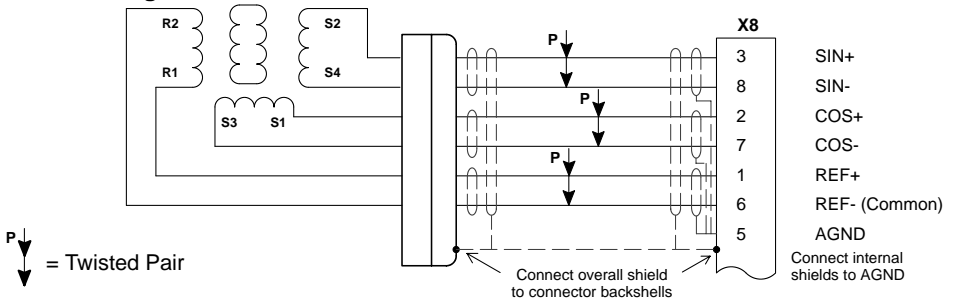

Figure 3-27 Resolver Cable Connections for CE Installations



X9 Handwheel (Encoder) Installation

Handwheel Mode (Standard Encoder)

Twisted pair shielded wire with an overall shield should be used. Figure 3-28 shows the electrical connections between the encoder and the encoder connector.

Note: If the control was ordered with option E (Encoder/Hall feedback, catalog FDxAxxx-Exxx) it is not possible to connect the handwheel.

Figure 3-28 Differential Encoder Connections for UL Installations

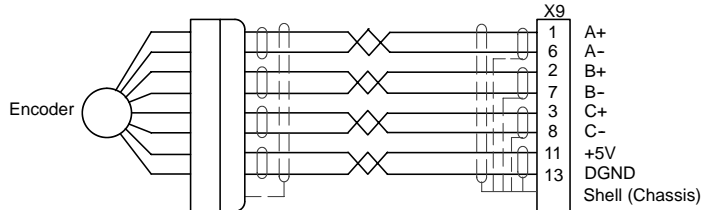

Single Ended Connections

Differential inputs are recommended for best noise immunity. If only single ended encoder signals are available, connect them to A, B, and C as shown in Figure 3-29.

Figure 3-29 Single Ended Encoder Connections for UL Installations

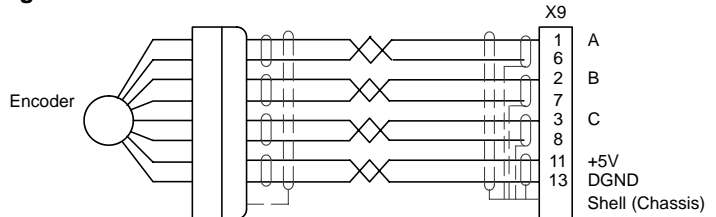
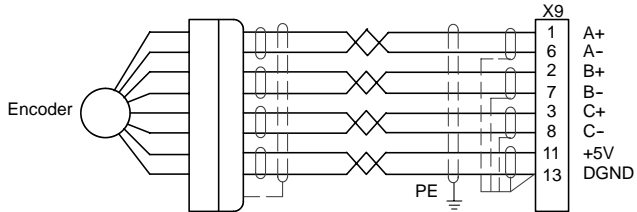
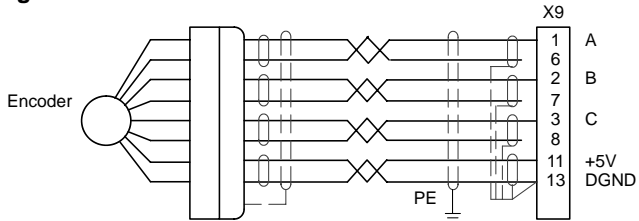

Figure 3-30 Differential Encoder Connections for CE Installations



Connection of shields to digital ground is optional.

Figure 3-31 Single Ended Encoder Connections for CE Installations



Connection of shields to digital ground is optional.

X9 Encoder w/Hall Tracks Optional (Option E)

Twisted pair shielded wire with an overall shield should be used. Figure 3-32 shows the electrical connections between the encoder and the encoder connector.

Note: If the control was ordered with option E (Encoder/Hall feedback, catalog FDxAxxx-Exxx) it is not possible to connect the handwheel.

Figure 3-32 Encoder with Hall Tracks Connections for UL Installations

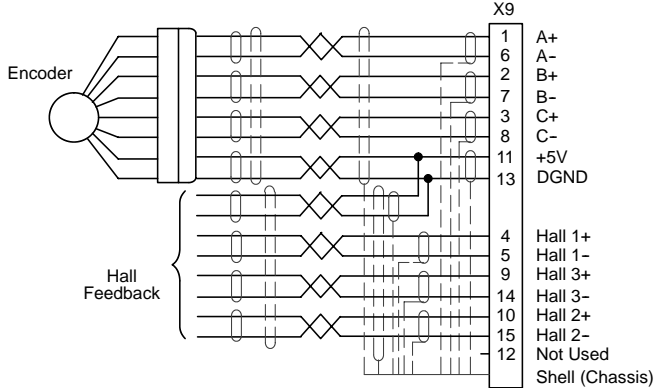
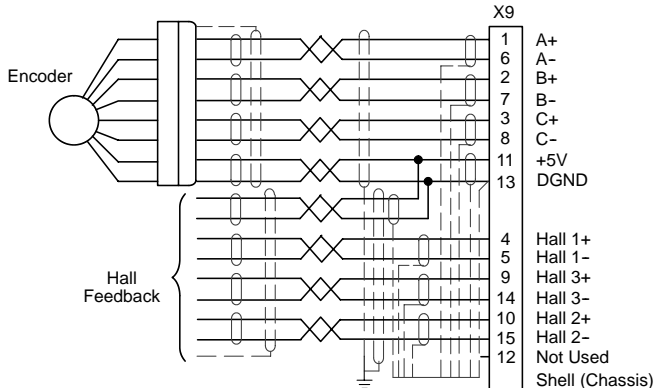

Figure 3-33 Encoder with Hall Tracks Connections for CE Installations



Section 4

Switch Setting and Start-Up

Switch AS1 Settings

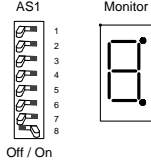

AS1 switches are located on the front panel between X1 and the “Monitor” LED.

Note: AS1–8 is shown in the “ON” position (Drive Enabled). All other switches are shown in the “OFF” position.

Address Setting, AS1-1 to AS1-4 (for Multi-Drop Applications)

Each control address can be set using switches AS1-1 to AS1-4 of each control. Each control must have a unique address. Refer to Table 4-1.

Table 4-1 Control Address Setting

AS1-1	AS1-2	AS1-3	AS1-4	Control Address (Hexadecimal)
OFF	OFF	OFF	OFF	0 (Factory Setting)
ON	OFF	OFF	OFF	1
OFF	ON	OFF	OFF	2
ON	ON	OFF	OFF	3
OFF	OFF	ON	OFF	4
ON	OFF	ON	OFF	5
OFF	ON	ON	OFF	6
ON	ON	ON	OFF	7
OFF	OFF	OFF	ON	8
ON	OFF	OFF	ON	9
OFF	ON	OFF	ON	A
ON	ON	OFF	ON	B
OFF	OFF	ON	ON	C
ON	OFF	ON	ON	D
OFF	ON	ON	ON	E
ON	ON	ON	ON	F

Setting of switches AS1-5 to AS1-8

The function of switches AS1-5 to AS1-8 are described in Table 4-2.

Table 4-2 AS1-5 to AS1-8 Description

Switch	Function	ON	OFF
AS1-5	Not Used		
AS1-6	Hold-Position	Hold-Position is active.	Hold-Position is not active
AS1-7	Offset Tuning	Automatic Offset Tuning is active.	Automatic Offset Tuning is not active.
AS1-8	Enable	Control is enabled (Enable is active)	Control is disabled (Enable is not active)

Hold-Position OFF allows normal operation.
ON causes the motor to quickly decelerate to rest and maintain a constant position (in current or velocity modes). (Time to max velocity = 0 with the Hold function.)

Offset Tuning OFF allows normal operation.
ON causes Offset Tuning to automatically start the next time Enable is changed from ON to OFF. The purpose of Offset Tuning is to remove DC offset voltages (on the command input X3-1 and X3-2) and achieve a stationary motor shaft with 0VDC at the command input. Leave this switch OFF when not in use. See Figure 4-1 for additional information.

Enable OFF disables the control and the motor coasts to a stop.
ON allows normal operation.
Note: AS1-8 and X3-9 must both be enabled to allow control operation.

Figure 4-1 Automatic Offset Tuning Timing Diagram

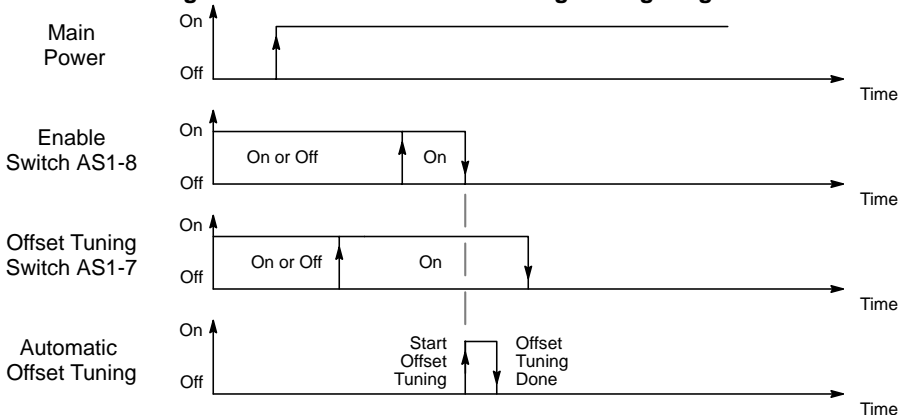

Note: It is important that you set the analog command to 0VDC before the Automatic Offset Tuning is started.

Start-Up Procedure

Power Off Checks

Before you apply power, it is very important to verify the following:

1. Disconnect the load from the motor shaft until instructed to apply a load. If this cannot be done, disconnect the motor wires at X1-U, V and W.
2. Verify that switches AS1-5 to AS1-8 are set to OFF.
3. Verify the AC line voltage at the source matches the control rated voltage.
4. Inspect all power connections for accuracy, workmanship and tightness.
5. Verify that all wiring conforms to applicable codes.
6. Verify that the control and motor are properly grounded to earth ground.
7. Check all signal wiring for accuracy.

Power On Checks

When power is first applied, the "Monitor" LED display will show four indications if there is no failure found.

8. All segments and decimal point are on.
- 0 Display test.
- 1 Option number of test (1, 2 etc.).
- d Final display with no decimal point (control disabled because AS1-8 = OFF).

Procedure:

1. Apply AC power.
2. Apply logic power (only if your control is equipped with this option).
3. Verify the Monitor LED power on sequence. If "d" is displayed, continue otherwise disconnect AC power and refer to the Troubleshooting procedure.
4. Disconnect AC power.
5. Connect the load to the motor shaft (or connect the motor wires at X1).
6. Apply Logic Power (24VDC) if option is present.
7. Apply AC power.
8. Set switches AS1-7 and AS1-8 to ON.
9. Set switch AS1-8 to OFF (initiate offset tuning).
10. Set switch AS1-7 to OFF.
11. Configure the control using the Setup Software provided. Refer to Section 5 of this manual.
12. Set switch AS1-8 to ON (drive enabled).
13. Perform System Tuning.

The drive is now ready for use.

Note: To protect the internal fuse, allow at least 1 minute after power down before turning power on (power Off/On cycle).

Section 5

Operation

Installing Software on your PC

The setup software is Windows-based. The servo control connects to a serial port on your PC. The setup wizard will guide you through the necessary steps to set-up your servo control. Online-help to each topic is available.

Minimum system requirements

Hardware requirements (minimum):

Processor: Intel 80486 / 33 MHz

RAM: 8 MB

Hard Disk Space: 50 MB

Screen: 600 x 480 (minimum)

Recommended: Intel Pentium, 16 MB RAM, 133 MHz, 100 MB Free Space

Software requirements:

Operating system: Windows 3.1x (minimum)

Recommended: Win95 or Windows NT

Installation

The following procedure will install the setup software on your computer's hard disk:

1. Start Windows. Make sure that no other programs are running during this installation.
2. Place installation **Disk #1** in your computer's floppy drive.
3. Run A:\Setup.exe (if A:\ is your floppy drive) or double click the file **Setup.exe** from My computer, 3.5 inch Floppy (A:).
4. Follow the instructions and insert the other installation disks as required.

After the installation process is finished, a program manager group for Flex with a Flex program icon is created. Double clicking this icon will start the setup program.

A file "Readme.txt" is included in the master directory of the software. This file contains installation instructions, change notices from previous revisions and information that became available after this manual was printed.

Host Communications Setup

Be sure the communications port of the PC is correctly set for communications with the Drive software. The following examples assume COM1 of the PC is used. If you are using COM2 - 4, substitute the correct COM port number in the example.

Windows 3.1 Terminal Emulation

1. Power up the Host and start Windows software.
2. In the "Windows Accessories Group" select "Terminal" ICON.
3. Select "Communications" from the Settings pull down menu within Terminal program.
4. Set the communications settings for:
 - 9600 Baud rate
 - 8 Data Bits
 - 1 Stop Bit
 - No Parity
 - Xon/Xoff Flow Control
 - COM1

5. Select "Binary Transfers" from the Settings pull down menu within Terminal program.
6. Set the Binary Transfer protocol to XModem/CRC.
7. Close menu and save the settings.
8. Terminal Communications settings are now complete.

Windows 95

1. Power up the Host and start Windows software.
2. In "Control Panel" select and open "System".
3. Open "Ports", select the COM port you are using then click "properties".

Figure 5-2



4. Be sure the port settings are as: Bits per second=9600, Data bits=8, Parity=none, Stop bits=1 and Flow control=Xon/Xoff.

Windows NT

1. Power up the Host and start Windows software.
2. In "Control Panel", select and open "Ports" then click "Settings".

Figure 5-3



3. Be sure the port settings are as: Bits per second=9600, Data bits=8, Parity=none, Stop bits=1 and Flow control=Xon/Xoff.

Using The Setup Wizard

The setup software wizard guides you through each step to set the basic parameters. This wizard is activated automatically after each start-up of the software. This automatic start of the Wizard can be turned off. It can be activated (and reset to automatic start) by **Help → Wizard**.

Figure 5-1 shows the flowchart of the Setup Wizard.

All selected parameters can be stored in a file. To save the configuration, select **Setup → Save Configuration**. To restore these parameter values or to configure a several controls with the same parameter sets, select the **Setup → Restore Configuration**.

Figure 5-1 Flowchart of the Setup Wizard

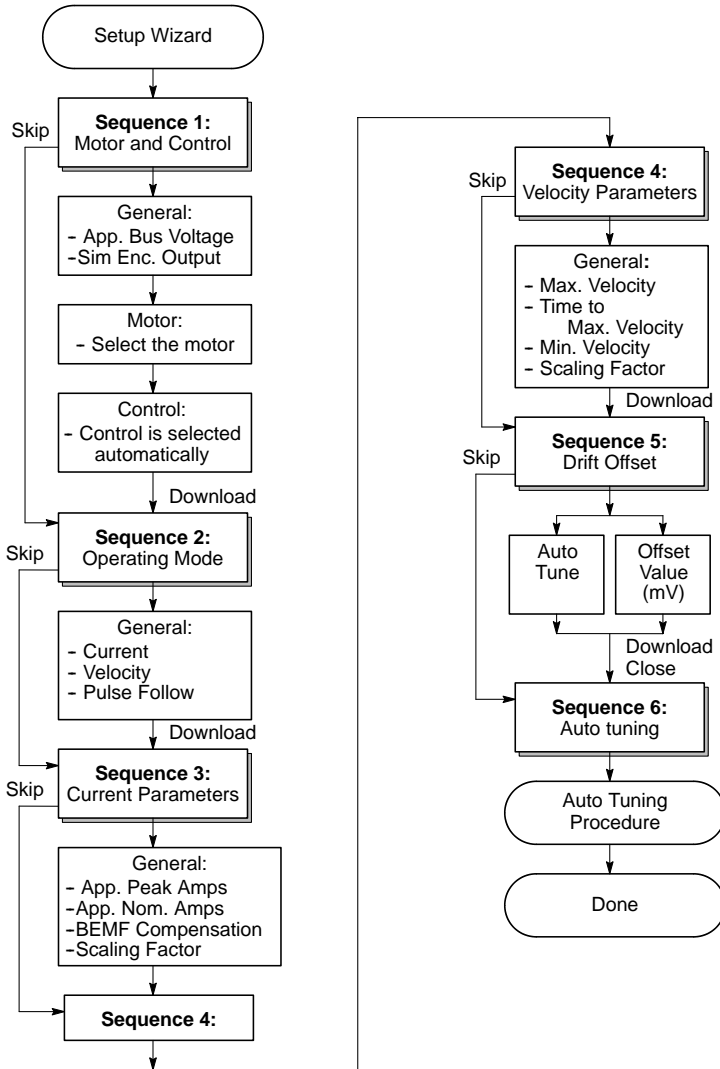

Set up Software Opening menu. Click NEXT to go to the Set up Software. If you have already set up the parameters and saved them to a file, click FINISH then load the parameter file using the File → Open selection.



Start by selecting the Motor and Control and these parameters will be entered automatically for you by the software for a stock motor. For a custom motor, the motor parameters must be entered on the general menu. First, click on "Motor" and then select "User Models" in the Library menu. Then, click "General" to return to this menu and enter all parameters.

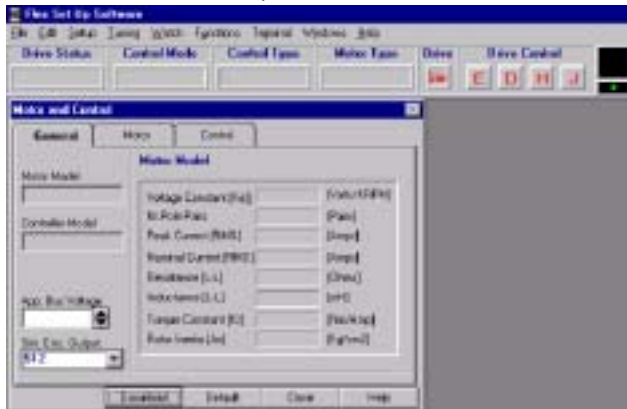

There are 7 parts to the setup procedure:

Motor

Select your motor from the list. First, select the general “Motor Type”. Then select your specific “Motor ID”. All of the parameters will be entered if your motor is on the list. If your motor is not on the list, you must define a motor and all of its parameters. If your motor is not listed, select “User Models” in the Library menu and enter the motor parameters. Click “Download” when finished.

Figure 5-2 Motor Selection Screen



Control

The “Control ID” is automatically selected. All of the parameters will be entered if your control is on the list. Click “Download” when finished.

Figure 5-3 Control Selection Screen



After the motor and control are selected, click the General menu and note that the values are filled in.

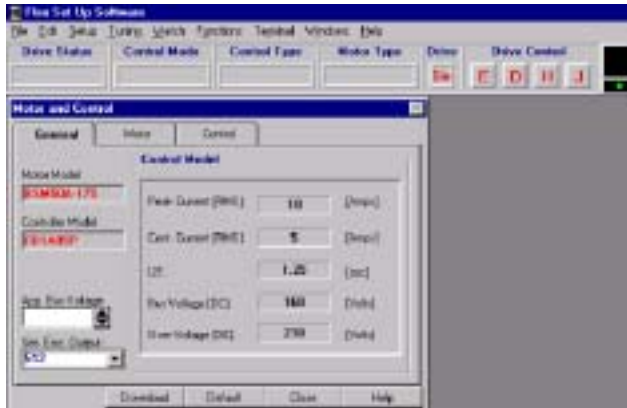

Operating Mode

Select the operating mode of the control. Choices are:

1. Current Mode
 2. Velocity Mode
 3. Pulse Follower Mode (Pulse & direction or Electronic Handwheel)
- Click "Download" when finished.

Note: If an encoder with hall feedback is plugged into X9, the handwheel cannot be used. Only one device may be plugged into X9.

Figure 5-4 Operating Mode Selection Screen



Current Parameter

Nominal and peak current values are automatically entered for the motor type. For manual tuning only, set the control current limit value to a percentage of the continuous current rating. For example, if your control is rated for 5A continuous current and you desire to limit the output current to 4A, enter 80%. If you wish to use the full output power of the control, enter 100%. Click “Download” when finished.

Figure 5-5 Current Parameter Screen



Velocity Parameter

Set the velocity parameters of the control:

1. Scale factor - ratio of the input voltage to output RPM.
 2. Minimum velocity
 3. Time to maximum velocity
- Click “Download” when finished.

Figure 5-6 Velocity Parameter Screen



Drift

If you know the input offset value of the control, you may enter the value manually. Otherwise, you may initiate automatic offset tuning and let the control measure and set this value. Click "Download" when finished.

Figure 5-7 Drift Parameter Screen



Autotune

You may manually tune the control (see appendix) or use autotune to allow the control to tune itself. Click "Download" when finished.

Figure 5-8 Autotune Screen



Main Menu Choice Descriptions

File

File	Edit	Tune	Watch	Function
New				→ Open a new editor window.
Open				→ Open an existing editor window.
Close				→ Close the active editor window.
All Close				→ Close all editor windows.
Save				→ Save the active editor window to a file.
Save as				→ Save the active editor window to a new file name .
All Save				→ Save all editor windows.
Print				→ Print the contents of the active editor window.
Exit				→ Exit and close the Set up software.

Edit

Edit	Tune	Watch	Function
Cut			→ Cut the selected text in the active editor window to the clipboard.
Copy			→ Copy the selected text in the active editor window to the clipboard.
Paste			→ Paste text from the clipboard at the cursor location in the active editor window.
Clear			→ Erase the contents of the active window.
Select all			→ Select everything in the active window.
Font			→ Save the active editor window to a new file name .

Setup

Setup	Tune	Watch	Function
Motor and Control			→ Allows selection of the motor being used.
Operation Mode			→ Allows selection of Current, Velocity or Pulse Follower modes.
Save Configuration			→ Allows PC to read the control configuration and save the parameters to a file.
Restore Configuration			→ Allows PC to read a configuration file and download parameters to the control.
Save Motion Buffer			→ Save the contents of the motion buffer to a file.
Load Motion Buffer			→ Restore a motion buffer file and downloads the parameters to the control.
Select Control			→ Select a control for communication (8 maximum in daisy chain).
JMAS Set/Read			→ Not available for this control.
Second Analog Command			→ Not available for this control.

Tuning



Allows manual or automatic tuning to remove offset drift.

Allows manual or automatic tuning of velocity control parameters.

Watch



Show or hide the "symbols list bar".

Show or hide the "system parameters bar".

Show or hide the "system status bar".

Gather and plot motor data for two variables.

View the error log.

View the available options for the selected control.

Functions

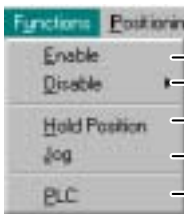

Enable the control.

Disable the control - Active: Motor decels to stop then control disables.
Passive: Motor coasts to stop.

Cause motor to stop and maintain position.

Allow you to Jog the position of the motor.

Define up to 12 PLC statements (logical association of input / output conditions).

Terminal



Allows communication with selected control using command set (see Appendix B).

Configure PC COM port 1, 2, 3 or 4 to communicate with the selected control.

Windows



Cascade display of all open software windows.

Tile display of all open software windows.

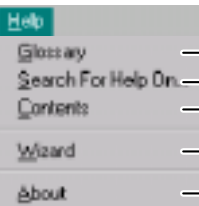

Alphabetic glossary listing of keywords.

Search for help based on a keyword.

Get help for a specific topic.

Starts the setup wizard to configure a motor and control.

Software version and release information.

PLC Program

At the main menu, select “Functions” then “PLC”. See Figure 5-9.

1. Determine which event (listed under the THEN column) you wish to use.
2. Next, click in the IF column on the same ROW as the desired event. For example, If you are to use the MA01 output, click in row 1 in the IF column as shown.
3. Choose the condition for the desired event.
4. Set other event conditions as desired.
5. Activate the PLC by selecting “Enable” on PLC Status.
6. Select “Download” to update the parameter values in the control.
7. Select “Close” when finished.

Note: To reset all IF conditions to False, select “Clear” located just below the Download selection. This will clear all condition choices.

Figure 5-9 PLC Program Menu

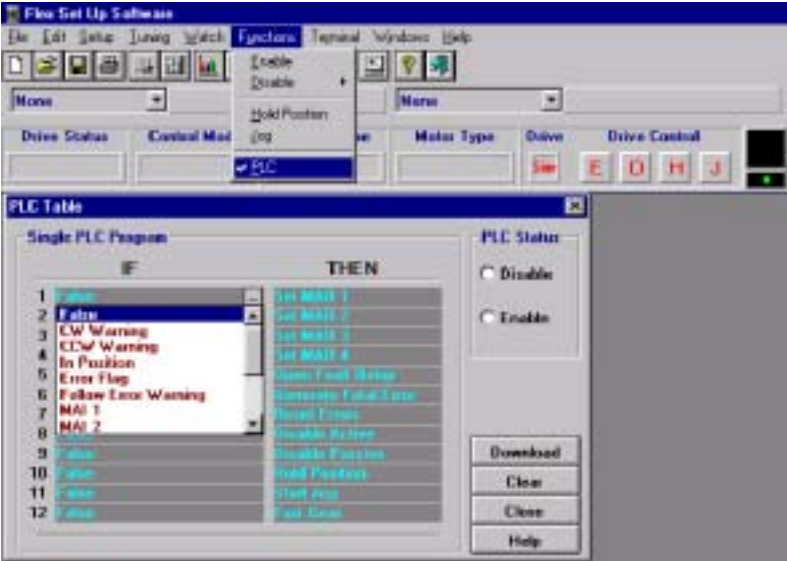

Section 6 Troubleshooting

Overview

The system troubleshooting procedures involves observing the status of the “Ready” LED, the “DB On” LED and the “Monitor” 7 segment display. The tables in this section provide information related to the indications provided by these devices.

Note: The “Ready” LED can display RED, YELLOW or GREEN color.

Table 6-1 Operating Mode Indications

Ready	Monitor	Status	Cause
OFF	OFF	Control Disabled	No Fault.
Green	Decimal Point	Control Enabled	Normal operating mode. No Fault.
Red	1	Over-voltage fault (DC Bus)	Missing, damaged or wrong REGEN resistor. Input voltage too high.
Red	3	Over-current fault. (More than 2X peak current)	Motor leads shorted or control failure. Load exceeds motor rating (too much current). Accel time set too short.
Red	4	Over or Under-voltage fault.	Internal 15VDC supply fault.
Red	5	Resolver fault (or encoder fault).	Resolver or cable short circuit or resolver not connected (open circuit).
Red	6	Electronic fusing (also see fault 7)	Control current over-load detected by software.
Red	7	I ² t limit reached. After a fault is detected, control will run at nominal output current for 2.5 seconds then stop. The control is disabled and the Monitor will first display “7” fault then the “6” fault. Control Over-Temperature	Cycle time between Acceleration and Deceleration is too short. Control should be relocated to cooler area. Add fans or air conditioning to control cabinet.
Red	9	User defined fault (see PLC).	
Red	0	Processor “Watchdog” timeout	Reset control (turn off AC power, wait 1 minute then turn power on).
Green	1	Move Command not accepted.	More than two move commands have been sent to the control. To return to normal status, send a “Quit” or a new move command to the control. A non-initialized buffer line has been called by the Machine inputs. To return to normal status, call an initialized buffer line by MA1-4 or send a “Quit” to the control.
Green	-1	CW Enable switch activated.	CW limit reached. Check X3-10 input.
Green	1-	CCW Enable switch activated.	CCW limit reached. Check X3-11 input.

Note: To protect the internal fuse, allow at least 1 minute after power down before turning power on (power Off/On cycle).

Table 6-1 Operating Mode Indications Continued

Ready	Monitor	Status	Cause
Red	A	EEPROM checksum error.	The personality must be downloaded to EEPROM and reset the control. If problem remains, contact Baldor.
Red	c	Velocity data in the EEPROM failed.	The velocity data must be downloaded to EEPROM and reset the control. If problem remains, contact Baldor.
Green	C	CAN bus problem detected.	("C" blinking) A communication error on the CAN bus exists. The control is still connected to the CAN bus.
Red	C	CAN bus problem detected.	("C" blinking) A communication error on the CAN bus exists. The control will attempt resynchronization to establish the CAN bus.
Green	d	Control Disabled.	Disable mode activated by hardware or software.
Green	E	Following Error.	The following error exceeded the user defined value of the Following Error Band. This error is not stored and goes away when the following error is reduced to within limits.
Green	F	Fatal Following Error.	The following error exceeded the user defined value of the Following Fatal Error. The following error preset level is "Operation Mode → Pulse Follower". This error is stored and must be cleared by the operator, but operation continues as long as the error is less than $\pm 2^{15}$ (± 32768).
Green	H	Hold-Position mode.	Hold mode activated by hardware or software.
Green	J	Jog mode.	Jog mode activated by hardware or software.
Red	L	Both limit switches active.	Defective or missing limit switch or wiring.
Green	P	In Position.	The following error is less than the user defined preset value.
Red	U	EPROM version fault.	The personality must be downloaded to EEPROM and reset the control.
Red	u	EEPROM version fault.	The personality must be downloaded to EEPROM and reset the control.

It is important to connect the motor leads U, V and W correctly at the X1 connector of the control. Incorrect wiring can cause erratic operation including moves at peak force until the overcurrent limit trips. This will result in a display of "7" and a "6" on the monitor. If erratic movement of the motor occurs, turn off power immediately and check the connections of the motor, hall sensors and encoder.

Section 7

Specifications & Product Data

Identification

Servo Control

FD X A X X X X -R C 4 3

Flex Drive

Input Voltage

- 1=115VAC
- 2=230VAC
- 4=460/400VAC

Current Rating

- A02 = 2 / 2.5 Amps
- A05 = 5 Amps
- A07 = 7.5 Amps
- A10 = 10 Amps
- A15 = 15 Amps
- A20 = 20 Amps
- A27 = 27.5 Amps

Enclosure Type

- T= Panel Mount w/internal power supply
- P= Panel Mount w/external power supply
- S = Panel Mount w/internal power supply (suitable for sharing with other controls).

Braking (Option)

- R = Requires external regen resistor
- B = Built-in regen resistor
- O = No internal regen capability

Logic Supply (Option)

- 0 = Internal 24VDC Supply
- 3 = External customer provided 24VDC required

Serial Port Type (Option)

- 2 = RS232
- 4 = RS485

Bus (Option)

- N = None
- C= CAN Bus *

Feedback Device (Option)

- R = Resolver
- E = Encoder

* CAN Bus is only available for controls with resolver feedback. Controls that have encoder feedback may not have CAN Bus.

Specifications

Description	Unit	FDX A02T	FDX A05T	FDX A07T	FDX ^② A02S	FDX ^② A05S	FDX ^② A010S	FDX ^② A015S
Input Voltage Range Nominal Minimum Maximum	VAC	115 / 230 92 / 184 132 / 265						
Input Frequency	Hz	50/60 ±5%						
Nominal Output Bus (@ 115 / 230 input) Nominal Minimum Maximum	VDC	160 / 320 88 / 176 180 / 360						
Nominal Phase Current (±10%)	ARMS	2.5	5.0	7.5	2.0	5.0	10	15
Peak Phase Current (±10%); for 2.4sec (+0.5s/-0sec) maximum ^①	ARMS	5	10	15	4	10	20	30
Nominal Output Power	KVA	1.01	2.17	2.99	0.87	2.17	4.33	5.2
Output Frequency	Hz	0 - 500						
Efficiency	%	>95						
Nominal Switching Frequency	KHz	8.5						
Current Loop Bandwidth	Hz	1200						
Velocity Loop Bandwidth	Hz	10 to 200 (software selectable)						
Mounting	-	Panel						
Package Size	-	A	B	C	E	E	E	E
Operating Altitude	Feet (Meters)	To 3300 feet (1000 meters). Derate the continuous and peak output current by 1.1% for each 330 feet (100 meters) above 3300 feet.						
Operating Temperature	°C	+0 to 40. Above 40°C, derate the continuous and peak output current by 2.5% per °C above 40°C. Maximum ambient is 50°C.						
Rated Storage Temperature	°C	-25 to +70						
Humidity	%	10% to 90% non-condensing						
Class of Protection (Enclosure)		IP20						
Shock		10G (according to DIN IEC 68-2-6/29)						
Vibration		1G @ 10 - 150 Hz (according to DIN IEC 68-2-6/29)						

^① Valid for zero current initial condition.

^② These specifications also apply to model FDxAxxP except it has DC input (no AC input).

All values at ambient temperature of 25°C unless otherwise stated.

For safe operation, allow a clearance distance between each control and on all sides of each control.

Specifications Continued

Description	Unit	FD4 A02TB	FD4 A05TB	FD4 A07TB	FD4 A15TR	FD4 A20TR	FD4 A27TR
Input Voltage Range Nominal Minimum Maximum	VAC	460 @ 60Hz / 400 @ 50Hz 400 / 360 528 / 480					
Input Frequency	Hz	50/60 ±5%					
Nominal Output Bus (@ 400 / 460 input) Nominal Minimum Maximum	VDC	565 / 678 509 / - - / 746					
Nominal Phase Current (±10%)	A _{RMS}	2.5	5	7.5	15	20	27.5
Peak Phase Current (±10%); 1.25s +0.25s/-0s □	A _{RMS}	5	10	15	30	40	55
Nominal Output Power	KVA	1.9	3.8	5.7	11.4	15.2	20.9
Output Frequency	Hz	0 - 500					
Efficiency	%	>95					
Nominal Switching Frequency	KHz	8.0					
Current Loop Bandwidth	Hz	1200					
Velocity Loop Bandwidth	Hz	10 to 200 (software selectable)					
Mounting	-	Panel					
Package Size	-	G	G	G	H	H	H
Operating Altitude	Feet (Meters)	To 3300 feet (1000 meters). Derate the continuous and peak output current by 1.1% for each 330 feet (100 meters) above 3300 feet.					
Operating Temperature	°C	+0 to 40. Above 40°C, derate the continuous and peak output current by 2.5% per °C above 40°C. Maximum ambient is 50°C.					
Rated Storage Temperature	°C	-25 to +70					
Humidity	%	10% to 90% non-condensing					
Class of Protection (Enclosure)		IP20					
Shock		10G (according to DIN IEC 68-2-6/29)					
Vibration		1G @ 10 - 150 Hz (according to DIN IEC 68-2-6/29)					

□ Valid for zero current initial condition.

All values at ambient temperature of 25°C unless otherwise stated.

For safe operation, allow a clearance distance between each control and on all sides of each control.

24VDC Logic Power Input (Option FDxAxxxx-xxx3 ONLY)

Description	Unit	FDX A02T	FDX A05T	FDX A07T	FDX A02S	FDX A05S	FDX A10S	FDX A15S
Input Voltage (maximum ripple = ±10%)	VDC	20 - 30						
Input Current @ 24VDC	A _{RMS}	0.55 - 0.8 <input type="checkbox"/>			1.4			
Power On surge current (24VDC 100msec)	A _{RMS}	4.0			2.5			

Depends on installed options.

24VDC Logic Power Input (Option FD4Axxxx-xxx3 ONLY) Continued

Description	Unit	FD4 A02	FD4 A05	FD4 A7	FD4 A15	FD4 A20	FD4 A27
Input Voltage (maximum ripple = ±10%)	VDC	20 - 30					
Input Current @ 24VDC	A _{RMS}	0.8	1.0	1.0	1.4	1.6	1.6
Power On surge current (24VDC 100msec)	A _{RMS}	4.0					

Velocity Control

Description	Unit	All
Command Input	VDC	0 to 10; or ±10
Command Signal Resolution	bit	12
Update Rate	μsec	500

Resolver Feedback

Description	Unit	All
Resolution (Automatically set by software. Depends on maximum speed.)	bit	Velocity < 6100RPM → Resolution 14 bits Velocity > 6100RPM → Resolution 12 bits
Pole Pairs		1
Resolver Winding Ratio		0.5

Simulated Encoder Output

Description	Unit	All
Signal		RS422
Encoder Resolution	ppr	512 / 1024 <input type="checkbox"/> / 2048 / 4096

Factory Setting

Pulse / Direction Input

Description	Unit	All
Signal	VDC	12 - 29 / Opto Isolated
Operating Mode		Pulse and Direction
Maximum Input Frequency	kHz	125
Cycle Time	msec	1

Encoder Input (Handwheel or Feedback)

Description	Unit	All
Signal Type		RS422
Operating Mode		A / B Quadrature
Maximum Input Frequency	kHz	125
Cycle Time	msec	1

Serial Interface (Option FDXAXXXX-XX2X)

Description	Unit	All
Communication Type		RS232C (not galvanically isolated)
Transmission Rate	Baud	9600 (not adjustable)

Optional Interface (Option FDXAXXXX-XX4X)

Communication Type		RS485 (not galvanically isolated)
Transmission Rate	Baud	9600 (not adjustable)

Regeneration (115 / 230VAC)

Description	Unit	FDX A02T	FDX A05T	FDX A07T	FDX A02S	FDX A05S	FDX A10S	FDX A15S
Switching Threshold 115VAC 230VAC	VDC	ON: 188 - 195 373 - 383	OFF: 183 - 188 362 - 372		ON: 180 388	OFF: 200 375		
Nominal / Peak Power (10% Duty Cycle)	kW	0.25 / 2.7						
Maximum Regeneration Switching Current	A	10						
Maximum Load Inductance	μH	100						

Regeneration (400 / 460VAC)

Description	Unit	FD4 A02	FD4 A05	FD4 A07	FD4 A15	FD4 A20	FD4 A27
Switching Threshold 400/460VAC	VDC	ON: 794 OFF: 787			ON: 794 OFF: 764		
Nominal / Peak Power (10% Duty Cycle)	kW	0.94 / 9.4			2.9 / 29		
Maximum Regeneration Switching Current	A	15			45	40	80
Maximum Load Inductance	μH	100					

Dimensions

Size A, B and C

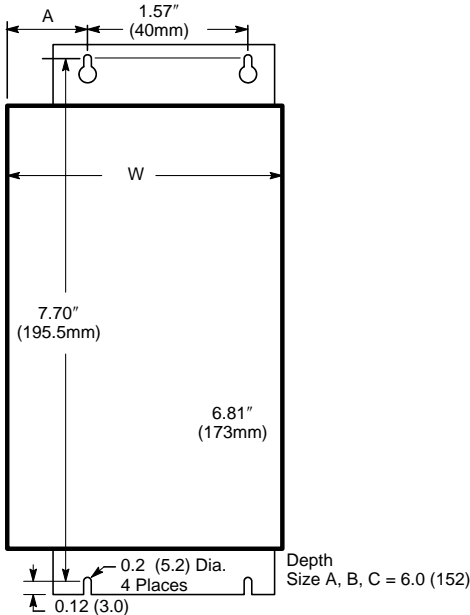

Clearance Requirements (all sizes):
 0.06" (15mm) top and bottom
 0.04" (10mm) left and right side

Size E, G and H

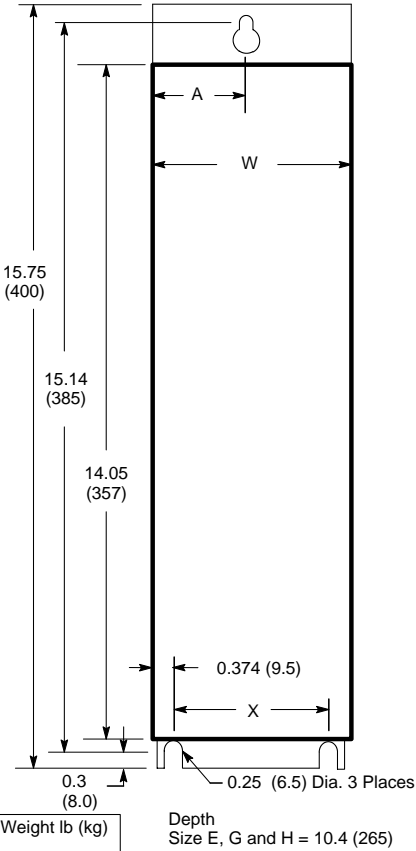

Package Size	Dimensions in (mm)			Weight lb (kg)
	A	W	X	
A	0.59 (15)	2.6 (67.5)	-	2.73 (1.24)
A w/CAN option	0.59 (15)	3.3 (84.0)	-	3.17 (1.44)
B	0.90 (23)	3.6 (92.5)	-	4.69 (2.13)
B w/CAN option	0.90 (23)	4.3 (109)	-	5.06 (2.3)
C	0.90 (23)	4.3 (109)	-	4.8 (2.19)
E	1.08 (27.5)	2.17 (55)	1.42 (36)	11 (5)
G	1.28 (32.5)	2.6 (65)	1.81 (46)	10.1 (4.6)
H	2.6 (65)	5.3(130)	4.37 (111)	20.9 (9.5)

For safe operation, allow a clearance distance between each control and on all sides of each control.

Section 8

CE Guidelines

CE Declaration of Conformity

Baldor indicates that the products are only components and not ready for immediate or instant use within the meaning of "Safety law of appliance", "EMC Law" or "Machine directive".

The final mode of operation is defined only after installation into the user's equipment. It is the responsibility of the user to verify compliance.

The product conforms with the following standards:

DIN VDE 0160 / 05.88	Electronic equipment for use in electrical power installations
DIN VDE 0100	Erection of power installations with nominal voltages up to 1000V
DIN IEC 326 Teil 1 / 10.90	Design and use of printed boards
DIN VDE 0110Teil 1-2 / 01.89	Dimensioning of clearance and creepage distances
DIN VDE 0110Teil 20 / 08.90	Distances
EN 60529 / 10.91	Degrees of protection provided by enclosures

EMC - Conformity and CE - Marking

The information contained herein is for your guidance only and does not guarantee that the installation will meet the requirements of the council directive 89/336/EEC.

The purpose of the EEC directives is to state a minimum technical requirement common to all the member states within the European Union. In turn, these minimum technical requirements are intended to enhance the levels of safety both directly and indirectly.

Council directive 89/336/EEC relating to Electro Magnetic Compliance (EMC) indicates that it is the responsibility of the system integrator to ensure that the entire system complies with all relative directives at the time of installing into service.

Motors and controls are used as components of a system, per the EMC directive. Hence all components, installation of the components, interconnection between components, and shielding and grounding of the system as a whole determines EMC compliance.

The CE mark does not inform the purchaser which directive the product complies with. It rests upon the manufacturer or his authorized representative to ensure the item in question complies fully with all the relative directives in force at the time of installing into service, in the same way as the system integrator previously mentioned. Remember, it is the instructions of installation and use, coupled with the product, that comply with the directive.

Wiring of Shielded (Screened) Cables

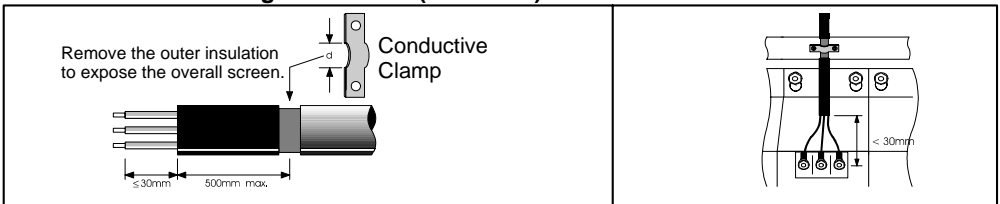

Using CE approved components will not guarantee a CE compliant system!

1. The components used in the drive, installation methods used, materials selected for interconnection of components are important.
2. The installation methods, interconnection materials, shielding, filtering and grounding of the system as a whole will determine CE compliance.
3. The responsibility of CE mark compliance rests entirely with the party who offers the end system for sale (such as an OEM or system integrator).

Baldor products which meet the EMC directive requirements are indicated with a "CE" mark. A duly signed CE declaration of conformity is available from Baldor.

EMC Wiring Technique

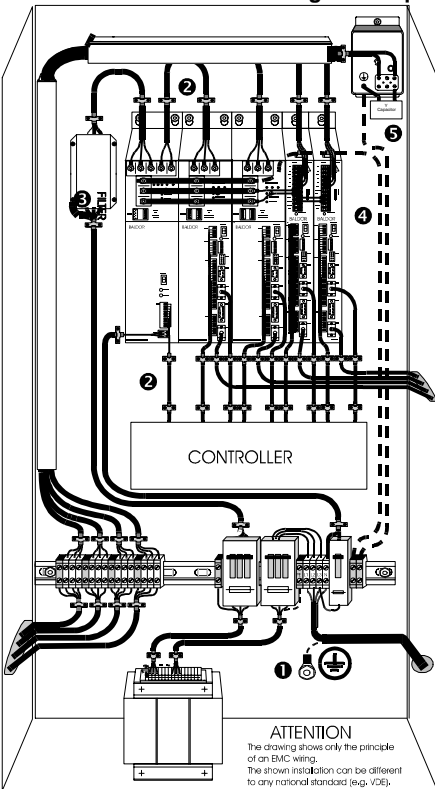

1 CABINET

The drawing shows an electroplated zinc coated enclosure, which is connected to ground.

This enclosure has the following advantages:

- All parts mounted on the back plane are connected to ground.
- All shield (screen) connections are connected to ground.

Within the cabinet there should be a spatial separation between power wiring (motor and AC power cables) and control wiring.

2 SCREEN CONNECTIONS

All connections between components must use shielded cables.

The cable shields must be connected to the enclosure. Use conductive clamps to ensure good ground connection. With this technique, a good ground shield can be achieved.

3 EMC - FILTER

The EMI or main filter should be mounted next to the power supply (here BPS). For the connection to and from the main filter screened cables should be used. The cable screens should be connected to screen clamps on both sides. (Exception: Analog Command Signal).

4 Grounding (Earth)

For safety reasons (VDE0160), all BALDOR components must be connected to ground with a separate wire. The diameter of the wire must be at minimum AWG#6 (10mm²). Ground connections (dashed lines) must be made from the central ground to the regen resistor enclosure and from the central ground to the Shared Power Supply.

5 Y-CAPACITOR

The connection of the regeneration resistor can cause RFI (radio frequency interference) to be very high. To minimize RFI, a Y-capacitor is used. The capacitor should only be connected between the dynamic brake resistor housing and terminal pin R1 (lead from Flex).

Recommendation: 0,1µF / 250VAC Type: PME265
BALDOR-Ordering-No.: ASR27104

EMC Installation Instructions

To ensure electromagnetic compatibility (EMC), the following installation instructions should be completed. These steps help to reduce interference. Consider the following:

- Grounding of all system elements to a central ground point
- Shielding of all cables and signal wires
- Filtering of power lines

A proper enclosure should have the following characteristics:

- A) All metal conducting parts of the enclosure must be electrically connected to the back plane. These connections should be made with a grounding strap from each element to a central grounding point . ¹
- B) Keep the power wiring (motor and power cable) and control wiring separated. If these wires must cross, be sure they cross at 90 degrees to minimize noise due to induction.
- C) The shield connections of the signal and power cables should be connected to the screen rails or clamps. The screen rails or clamps should be conductive clamps fastened to the cabinet. ²
- D) The cable to the regeneration resistor must be shielded. The shield must be connected to ground at both ends.
- E) The location of the AC mains filter has to be situated close to the drive so the AC power wires are as short as possible.
- F) Wires inside the enclosure should be placed as close as possible to conducting metal, cabinet walls and plates. It is advised to terminate unused wires to chassis ground. ¹
- G) To reduce ground current, use at least a 10mm² (6 AWG) solid wire for ground connections.

- ¹ Grounding in general describes all metal parts which can be connected to a protective conductor, e.g. housing of cabinet, motor housing, etc. to a central ground point. This central ground point is then connected to the main plant (or building) ground.
- ² Or run as twisted pair at minimum.

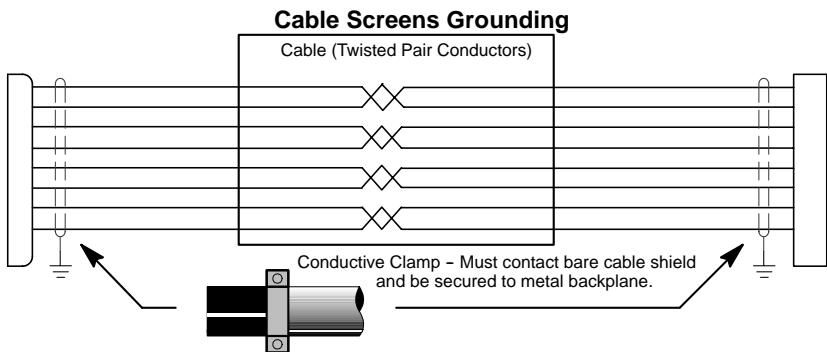

Input Signal Cable Grounding

**Control
X3**

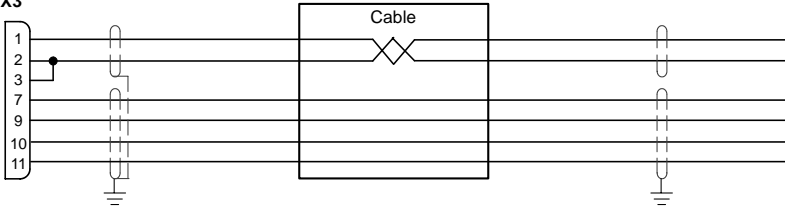

Simulated Encoder Output Cable Grounding

**Control
X7**

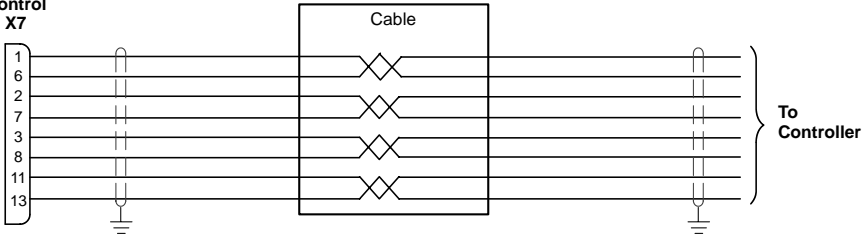

Resolver Cable Grounding

**Control
X8**

**Resolver Connector
Housing**

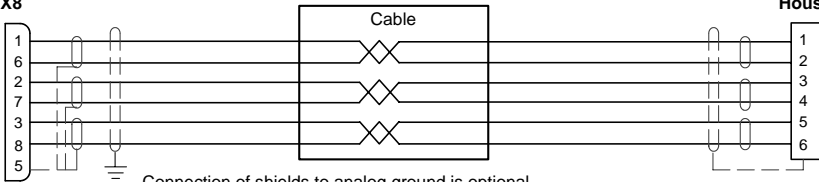

Connection of shields to analog ground is optional.

Encoder Cable Grounding

**Control
X9**

**Encoder Connector
Housing**

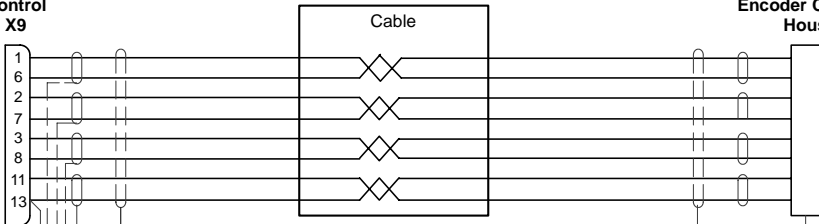

Connection of shields to digital ground is optional.

Section 9 Accessories and Options

Cables

Shielded (Screened) cable provides EMI / RFI shielding and are required for compliance to CE regulations. All connectors and other components used must be compatible with this shielded cable.

Motor Power Cable

Cable Rated Current	Cable Assembly Description	Baldor Catalog Number	Length	
			Feet	Meters
20 Amps	Power Cable Assembly Threaded connector (Standard-Metric Style)	CBL015SP-FHM	5	1.5
		CBL030SP-FHM	10	3.0
		CBL046SP-FHM	15	4.6
		CBL061SP-FHM	20	6.1
		CBL076SP-FHM	25	7.6
	Power Cable Assembly Quick Connect Style	CBL152SP-FHM	50	15.2
		CBL015SP-FHQ	5	1.5
		CBL030SP-FHQ	10	3.0
		CBL046SP-FHQ	15	4.6
		CBL061SP-FHQ	20	6.1
	Power Cable Assembly CE Style Threaded Connector	CBL076SP-FHQ	25	7.6
		CBL152SP-FHQ	50	15.2
		CBL030SP-FHCE	10	3.0
	Power Cable No Connectors	CBL061SP-FHCE	20	6.1
		CBL091SP-FHCE	30	9.1
		CBL152SP-FHCE	50	15.2
CBL030SP-F		10	3.0	
CBL046SP-F		15	4.6	
CBL061SP-F		20	6.1	
CBL076SP-F		25	7.6	
30 Amps	CBL091SP-F	30	9.1	
	CBL152SP-F	50	15.2	
	CBL030SP-E	10	3.0	
	CBL046SP-E	15	4.6	
	CBL061SP-E	20	6.1	
	CBL091SP-E	30	9.1	
	CBL152SP-E	50	15.2	

Connectors

Mating Connector by connector number (for spare parts)

- X1 - #ASR29714 (9 pin, Female) Phoenix Part No. MVSTBW2,5/9-ST
- X1 - #ASR29715 (2 pin, Female) Phoenix Part No. MVSTBW2,5/2-ST
- X3 - #ASR16000 (20 pin, Female) Phoenix Part No. MVSTBR2,5/20-ST
- X6 - #ASR16215 (9 pin, Male)
- X7 - #ASR16215 (9 pin, Male)
- X8 - #ASR23345 (9 pin, Female)
- X9 - #ASR25828A (15 pin, Male)

Resolver Feedback Cable

Motor Type	Cable Assembly Description	Baldor Catalog Number	Length	
			Feet	Meters
BSM 50/63/80/90/100	Resolver Feedback Cable Assembly Threaded connector (Standard-Metric Style)	CBL015SF-ALM	5	1.5
		CBL030SF-ALM	10	3.0
		CBL046SF-ALM	15	4.6
		CBL061SF-ALM	20	6.1
		CBL076SF-ALM	25	7.6
		CBL152SF-ALM	50	15.2
	Resolver Feedback Cable Assembly Quick Connect Style	CBL015SF-ALQ	5	1.5
		CBL030SF-ALQ	10	3.0
		CBL046SF-ALQ	15	4.6
		CBL061SF-ALQ	20	6.1
		CBL076SF-ALQ	25	7.6
		CBL152SF-ALQ	50	15.2
	Resolver Feedback Cable Assembly CE Style Threaded Connector	CBL030SF-ALCE	10	3.0
		CBL061SF-ALCE	20	6.1
		CBL091SF-ALCE	30	9.1
CBL152SF-ALCE		50	15.2	
BSM 50/63/80/90/100	Resolver Feedback Cable No Connector	CBL030SF-A	10	3.0
		CBL061SF-A	20	6.1
		CBL091SF-A	30	9.1
		CBL152SF-A	50	15.2

EMC AC Mains Filter AC filters remove high frequency noise to protect the control. These filters also prevent high frequency signals from being transmitted back onto the power lines and help meet CE requirements. To select the proper filter, you must know the voltage and current used by the drive and the impedance of the AC line.

For package size A, B and C (Model T - 1 Phase)

Filter Type	Rated Volts	Rated Amps @ 40°C	Leakage Current mA	Weight lbs (kg)	Baldor No.
FN 2070 - 12	250	12	0.4	1.61 (0.73)	30548

For package size E, G and H (Model S - 3 Phase)

Filter Type	Rated Volts	Rated Amps @ 40°C	Leakage Current mA	Power Losses Watts	Weight lbs (kg)	Baldor No.
FN 351 - 8 - 29	440	8	16	8.0	3.97 (1.8)	ASR24667
FN 351 - 16 - 29	440	16	16	9.0	3.97 (1.8)	ASR24668
FN 351 - 25 - 33	440	25	170	9.0	6.61 (3.0)	ASR24669
FN 351 - 36 - 33	440	36	170	10.5	6.61 (3.0)	ASR24670
FN 351 - 50 - 33	440	50	190	12.5	6.83 (3.1)	ASR24671

For package size E, G and H (Model T - 3 Phase Required for LD4xx)

Filter Type	Rated Volts	Rated Amps @ 40°C	Leakage Current mA	Weight lbs (kg)	Baldor No.
FN 3258 - 30 - 47	480	30	184.7	2.64 (1.2)	ASR30521
FN 3258 - 7 - 45	480	7	172.4	0.11 (0.5)	ASR30522

AC Filter Dimensions Continued

Dim.	For FN350	For Filters: FN 351 -			
		8 - 29	16 - 29	25 - 33	36 - 33 50 - 33
A	5.4 (139)	8.6 (220)	9.45 (240)	9.84 (250)	
B	3.9 (99)	7.1 (180)	7.87 (200)	7.87 (200)	
C	4.2 (105)	4.5 (115)	5.9 (150)	5.9 (150)	
D	3.32 (84.5)	3.35 (85)	4.7 (119.5)	4.72 (120)	
E	3.73 (95)	3.93 (100)	5.31 (135)	5.31 (135)	
F	2.24 (57)	2.36 (60)	2.55 (65)	2.55 (65)	
G	0.39 (10)	0.39 (10)	0.39 (10)	0.78 (20)	
H	1.74 (19)	0.76 (19.5)	1.22 (31)	0.83 (21)	

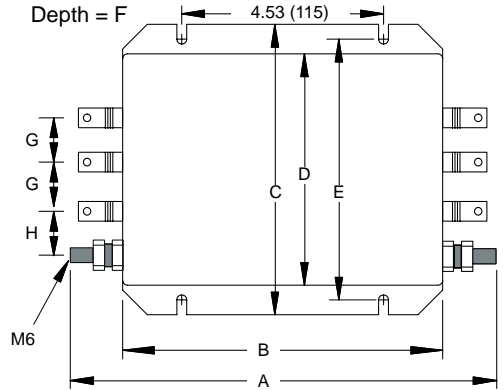

AC Filter Dimensions Continued

Dim.	For Filters:	
	FN3358-7-45	FN3358-30-47
A	7.48 (190)	10.63 (270)
B	6.29 (160)	9.45 (240)
C	7.08 (180)	10.04 (255)
D	0.79 (20)	1.18 (30)
E	0.18 (4.5)	0.21 (5.4)
F	2.75 (70)	3.35 (85)
G	1.57 (40)	1.97 (50)

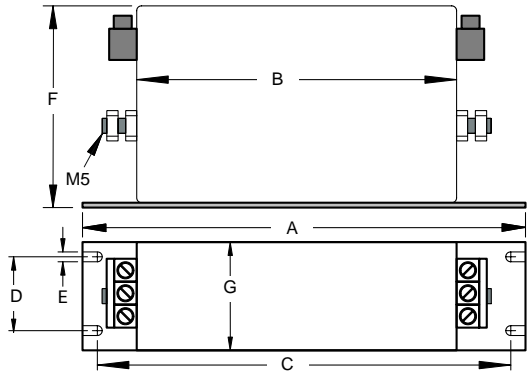

Regeneration Resistor

A regeneration resistor should be installed to dissipate energy during braking if a Fault "1" (over-voltage) occurs.

Control Rated Amps	Control Size	Baldor Catalog Number					
		115VAC Controls		230VAC Controls		400/460VAC Controls	
		Resistor Catalog No.	Resistor Watts	Resistor Catalog No.	Resistor Watts	Resistor Catalog No.	Resistor Watts
2.5	A	RG27	44	RG56	44		
5	B	RG27	44	RG56	44		
7.5	C	RG22	100	RG39	100		
2.5	G					* RG68	320
5	G					* RG68	320
7.5	G					RG68	320
15	H					RG27A	320
20	H					RG11	640
27.5	H					RG11	640
2	E	RG4.7	320	RG10	320		
5	E	RG4.7	320	RG10	320		
10	E	RG4.7	320	RG10	320		
15	E	RG4.7	320	RG10	320		

* These controls have a 200 ohm, 50 watt resistor installed (internal). An RG68 resistor can be installed in parallel for additional capability.

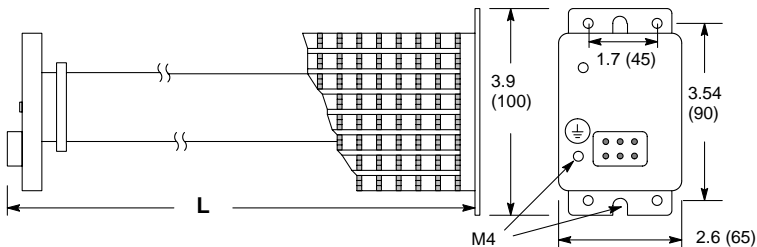

L = 5.5 (140) for 44 watt
 8.9 (228) for 100 watt
 13.2 (337) for 320/640 watt

Clearance Requirements (all sizes):
 2" (51mm) top and bottom
 1" (26mm) left and right side

For safe operation, allow a clearance distance between each control and on all sides of each control.

CAN Bus (Optional - Not available for controls with encoder feedback.)

Controls that are supplied with the CAN bus option have two additional connectors, X10 and X11 (conform to DS102, version 2.0). These are shown in Figure 9-1. CAN is a factory installed option.

Figure 9-1 CAN Bus Connectors

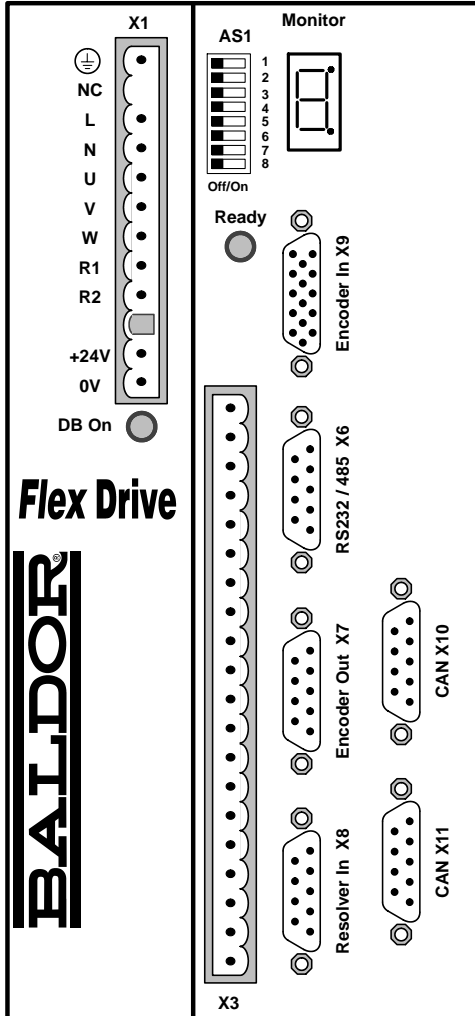

Note: On some models, the width of the control may increase slightly when equipped with the CAN option.

X10 - CAN Bus

- | | |
|------------|------------|
| 1 Reserved | 6 GND |
| 2 CAN_L | 7 CAN_H |
| 3 GND | 8 Reserved |
| 4 Reserved | 9 VCC |
| 5 Reserved | |

X11 - CAN Bus

- | | |
|------------|------------|
| 1 Reserved | 6 GND |
| 2 CAN_L | 7 CAN_H |
| 3 GND | 8 Reserved |
| 4 Reserved | 9 VCC |
| 5 Reserved | |

Figure 9-2 CAN Bus Interconnections

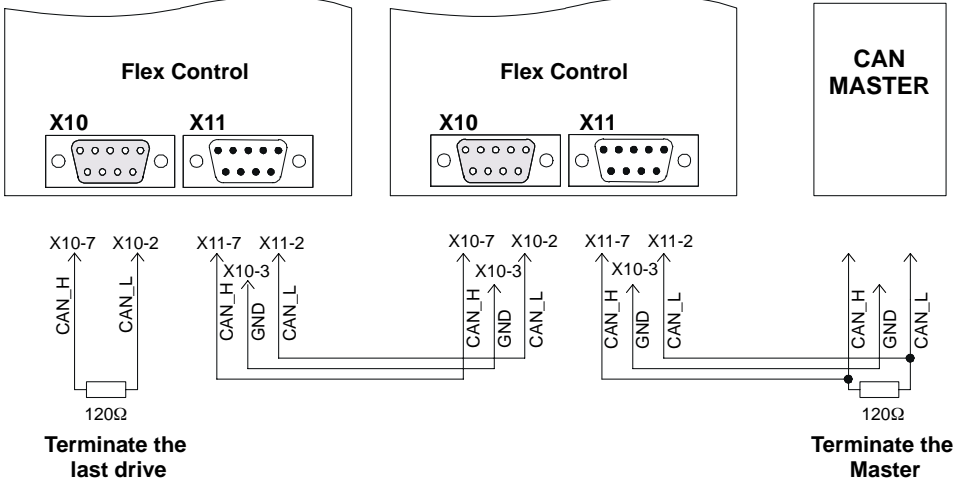

CAN Bus Protocol

Baldor uses CAN_OPEN, DS 301 protocol.

Baud rate is preset to 125kbit/second may be changed by AS1 switch settings or serial command (e.g. command: CAN.BD = 1000 for 1Mbit/sec). Available baud rates are: 10, 20, 50, 100, 125, 250, 500, 800, and 1000kbit/sec.

NODE ID may be changed by switch settings or serial command (e.g. command: CAN.ID = 50). Available addresses are 1 to 127.

CAN Bus Features

The following features are available with the Baldor CAN_OPEN structure:

- One SDO
- Two PDO's; each for transmit and receive (synchronous or asynchronous)
- SYNC message
- EMERGENCY object
- Default and variable PDO mapping
- All ID's can be set with SDO
- Node guarding
- Simple boot-up

Index Range The index range from 0x1000 to 0x100D is valid.
The following index ranges are important:

0x1400	1st PDO receive (communication)
0x1402	2nd PDO receive (communication)
0x1600	1st PDO receive (mapping)
0x1602	2nd PDO receive (mapping)
0x1800	1st PDO transmit (communication)
0x1802	2nd PDO transmit (communication)
0x1A00	1st PDO transmit (mapping)
0x1A02	2nd PDO transmit (mapping)

Object Entries The following object entries are available with PDO:

- Read position (absolute and resolver position)
- Read and write velocity
- Read status
- Write torque

The following object entries are available with SDO:

- Variables and commands

Getting Started with CAN OPEN

The CAN message transmission consists of an address (=Identifier = ID) followed by 0 to 8 Data bytes. CAN drives use the following addresses (according to CAN_OPEN, DS301):

PDO1 (Receive, Master to Drive): 0x200 + Node_ID

PDO2 (Receive, Master to Drive): 0x300 + Node_ID

PDO1 (Transmit, Drive to Master): 0x180 + Node_ID

PDO2 (Transmit, Drive to Master): 0x280 + Node_ID

NMT: 0x000

SYNC: 0x80

EMERGENCY: 0x80 + Node_ID

SDO (Master to Drive): 0x600 + Node_ID

SDO (Drive to Master): 0x580 + Node_ID

PDO = Process data transfer, fast communication ex: velocity command.

SDO = Service data transfer, slow communication to access all parameters inside the drive.

NMT = Network management task, to switch the PDOs free and to reset the drive.

SYNC = Specific CAN_OPEN message to do some synchronization.

EMERGENCY: The drive will send this message automatically if a fatal drive error occurs

Node_ID: Special setting (= drive number) for each drive. Range : 1 to 127

The default Baud rate is set to 125 kbit/second and the Node_ID is the drive address+1 (AS1 switches 1 to 4).

Note: Every drive, connected to one CAN Bus system must have a different Node_ID.

After power up you will receive an EMERGENCY message with two data bytes (0x00 and 0x00) to inform you that the CAN_DRIVE is now active.

Now you will have access to all commands via SDO. If you want to give a command or set a parameter, you have to put the following message on the CAN_BUS:

To send a command or set a parameter in the drive:

PC Master	D0	D1	D2	D3	D4	D5	D6	Drive D7
	0x20	Ind_lo	Ind_hi	Sub	XXX	XXX	XXX	XXX
	ID = 0x600 + NODE_ID <-----							
	0x20	Ind_lo	Ind_hi	Sub	XXX	XXX	XXX	XXX
	ID = 0x580 + NODE_ID <-----							

Where:

- X Data bytes (to write a parameter)
- ID Identifier
- 0x Hexadecimal data format
- D0 - D7 Data byte 0 to 7 of CAN message
- Ind_lo Low byte of Index of Object dictionary
- Ind_hi High byte of Index of Object dictionary
- Sub Subindex of Object dictionary. If Object has only one entry, Subindex must always be 0

Note: If the first data byte in the returned message from the drive = 0x80, the commanded action failed.

To read a parameter from the drive:

PC Master							Drive
D0	D1	D2	D3	D4	D5	D6	D7
0x40	Ind_lo	Ind_hi	Sub	XXX	XXX	XXX	XXX
ID = 0x600 + NODE_ID <-----							
0x60	Ind_lo	Ind_hi	Sub	0x00	0x00	0x00	0x00
ID = 0x580 + NODE_ID <-----							

Where:
 X Don't care
 ID Identifier
 0x Hexadecimal data format
 D0 - D7 Data byte 0 to 7 of CAN message
 Ind_lo Low byte of Index of Object dictionary
 Ind_hi High byte of Index of Object dictionary
 Sub Subindex of Object dictionary. If Object has only one entry, Subindex must always be 0
 P_lsb Low byte of requested parameter
 P_msb High byte of requested parameter

Note: If the first data byte in the returned message from the drive = 0x80, the commanded action failed.

To send a velocity command to the drive:

1. Verify that the correct motor and drive parameters and operating mode are set. This is done by CAN or RS232 communications.
2. Send the following CAN messages to the drive.

ID	D0	D1	D2	D3	D4	D5	D6	D7	Description
0x601	0x20	0x8F	0x21	0x00	0x08	XXX	XXX	XXX	Select CAN card for velocity command.
0x581	0x60	0x8F	0x21	0x00	0x00	0x00	0x00	0x00	Drive response with "OK".
0x601	0x20	0x83	0x21	0x00	XXX	XXX	XXX	XXX	Enable drive.
0x581	0x60	0x8F	0x21	0x00	0x00	0x00	0x00	0x00	Drive response with "OK".
0x601	0x20	0x90	0x20	0x00	Vl	Vm	XXX	XXX	Velocity command (Vl=lsb; Vm=msb. Scaling=bits/msec)
0x581	0x60	0x8F	0x21	0x00	0x00	0x00	0x00	0x00	Drive response with "OK".

Note: Every command is answered by the drive. Allow time for the response.

Summary:

With a CAN_OPEN master you don't need to know each data byte. Therefore you only should be informed about the object dictionary, which you will find in the Appendix.

Appendix: Object dictionary
 ASCII command set description

Identifiers and object list

The distribution of the identifiers of the supported objects conforms to Can Open (DS301, V 3.0, S. 8–12).

Message / Object	Function Code	COB - Identifier	Services
NMT Services	0	0 (broadcast)	Start_Remote_Node Stop_Remote_Node Pre-Operational-State NMT_Reset_Node NMT_Reset_Com
Sync. Emergency	1 1	128 (broadcast) 128 + Node_ID	Synchronization Emergency (fault)
PDO1 (tx)		384 + Node_ID	Transmit PDO (asynchronous)
PDO1 (rx)		512 + Node_ID	Receive PDO (asynchronous)
PDO2 (tx)		640 + Node_ID	Transmit PDO (synchronous)
PDO2 (rx)		768 + Node_ID	Receive PDO (synchronous)
SDO (tx)		1408 + Node_ID	Transmit SDO
SDO (rx)		1536 + Node_ID	Receive SDO
Node guarding		1760	NMT node guarding

Node_ID is the node identifier, which is the card-address (set by switch AS1–4).

SDO Protocols (CMS Multiplexed Domain Protocols)

In CiA/DS202–2 CMS protocol specification, the following specifications of the SDO COB identifier. This protocol specifies the meaning of the content of the 8 data bytes transferred within a CAN Message for the different domain protocols.

Byte 1	Byte 2	Byte 3	Byte 4	Byte5 to Byte 8
Protocol	Multiplexer or Data Bytes			up to 4 Data Bytes
Control Bits	index, lsb	index, msb	sub-index	Data (byte 5 is lsb; byte 8 is msb)

Multiplexed: Same identifier, message indication by Index + Subindex

Expedited: Used, if data to be transported is less or equal 4 byte (long int, 32 Bit)

The following tables list the meaning / setting of the control bits of first byte (x = not used, always 0) to select the protocol and the correspondent meaning of the further 7 data bytes of the CAN frame.

Expedited domain download and initiate domain download

Domain Protocols	7..5:	4:	3..2:n	1:e	0:s	= 1.byte	m	up to 4 data bytes
Expedited Domain Download Request Confirm	ccs 001 scs 011	x x	(0 or n) x	1 x	s x	=22, 2x1 =60	multiplexor	data to be downloaded
Initiate Domain Download Request Confirm	ccs 001 scs 011	x x	x x	0 x	s x	=20, 2x2 =60	multiplexor	if s=1: number of data reserved

- n: If e=1 & s=1, n indicates the number of bytes, which do not contain data (therefore only valid for expedited protocol)
- s: Data set size is not indicated / indicated: 0 / 1
- ¹ If s=1, the 1.byte contains: 23 or (n shifted 2 left)
- ² If s=1, the 4 data bytes contain the number of data bytes to be transferred in the segmented domain.

Segmented domain download

Domain Protocols	7..5:	4: t	3..1:n		0:c	= 1.byte	up to 3+	up to 4 data bytes
Download Domain Segment Request Confirm	ccs 000 scs 001	0 / 1 0 / 1	n x		0	=00 / 10 =20 / 30	7 data bytes to be downloaded	Reserved
End of Download Domain Segment Request Confirm	ccs 000 scs 001	0 / 1 0 / 1	n x		1 x	=0X / 1X ⁹ =20 / 30	≤7 data bytes to be downloaded	Reserved

- t: Toggle bit of segmented domain, with first download domain segment t=0
- n: n indicates the number of bytes, which do not contain data
- c: 1 if last segment to be downloaded, else 0
- ³ The 1. byte contains: 01 or (n shifted 1 left)

Expedited domain upload and initiate domain upload

Domain Protocols	7..5:	4: t	3..1:n	1:e	0:c	= 1.byte	m	up to 4 data bytes
Expedited Domain Upload Request Confirm	ccs 001 scs 010	x x	x (0 or n)	X 1	x s	=40 =42, 4X ⁴	multiplexor	reserved data to be downloaded
Initiate Domain Upload Request Confirm	ccs 001 scs 010	x x	x 0	x 0	x s	=40 =40, 41	multiplexor	reserved if s=1: number of data

- n: If e=1 & s=1, n indicates the number of bytes, which do not contain data
- s: Data set size is not indicated / indicated: 0 / 1, in the case of expedited protocol s indicates that n gives the number of non-data bytes, in the case of initiate protocol s indicates that the four data bytes 5. data byte 5 .. 8. data byte contain the total number of bytes to be uploaded.
- ⁴ If s=1, the 1.byte contains: 43 or (n shifted 2 left)

Segmented domain upload

Domain Protocols	7..5:	4: t	3..1:n		0:c	= 1.byte	up to 3+	up to 4 data bytes
Upload Domain Segment Request Confirm	ccs 001 scs 000	0 / 1 0 / 1	x n		x 0	=60 / 70 =0E / 1E	Reserved	7 data bytes to be downloaded
End of Upload Domain Segment Request Confirm	ccs 011 scs 000	0 / 1 0 / 1	x n		x 1	=60 / 70 =0X / 1X ⁵	Reserved	≤7 data bytes to be downloaded

t: Toggle bit of segmented domain, with first upload domain segment t=0

n: n indicates the number of bytes, which do not contain data

c: 1 if last segment to be uploaded, else 0

5 The 1. byte contains: 01 or (n shifted 1 left)

Abort Domain Transfer (Unconfirmed)

Domain Protocols	7..5:	4.0				1.byte	m	up to 4 data bytes
Expedited Domain Upload Request	c100	x				⁸⁰	multiplexor	reason for the abort

Object Dictionary (CAN - Version: 23310D)

Index (hex)	Object	Used	
0000	not used		
0001 - 001F	Static Data Types	OBJECT_UNSIGNED8	0005
0020 - 003F	Complex Data Types		
0040 - 005F	Manufacturer Specific Data Types		
0060 - 007F	"Device Profile Specific Static Data Types"		
00A0 - 0FFF	"Reserved for future use "		
1000 - 1FFF	Communication Profile Area	DEVICE_TYPE ERROR_REGISTER MANUFACT_STATUS_REGISTER PREDEFINED_ERROR_FIELD NUMBER_OF_PDOS COB_ID_SYNC_MSG COMMUNI_CYCLE_PERIODE SYNCHRON_WINDOW_LENGTH MANUFACT_DEVICE_NAME MANUFACT_HW_VERSION MANUFACT_SW_VERSION NODE_ID GUARD_TIME LIFE_TIME_FACTOR RECEIVE_PDO_2_COMMUNI_PARAM RECEIVE_PDO_1_COMMUNI_PARAM RECEIVE_PDO_2_MAPPING_PARAM RECEIVE_PDO_1_MAPPING_PARAM TRANSMIT_PDO_2_COMMUNI_PARAM TRANSMIT_PDO_1_COMMUNI_PARAM TRANSMIT_PDO_2_MAPPING_PARAM TRANSMIT_PDO_1_MAPPING_PARAM	1000 1001 1002 1003 1004 1005 1006 1007 1008 1009 100A 100B 100C 100D 1400 1402 1600 1602 1800 1802 1A00 1A02
2000 - 5FFF	Manufacturer Specific Profile Area	MANUFACT_NODI_ID MANUFACT_BAUD_RATE Objects with Subindexes (2010 - 2020): MANUFACT_CUR_CONTROLLER MANUFACT_VEL_CONTROLLER MANUFACT_HANDWHEEL_PARAM MANUFACT_POS_CONTROLLER MANUFACT_MOTOR_PARAM MANUFACT_DRIVE_PARAM MANUFACT_SYS_PARAM MANUFACT_JOG_PARAM MANUFACT_MOT_PARAM MANUFACT_HOM_PARAM MANUFACT_LIM_PARAM MANUFACT_COM_JOG MANUFACT_COM_MOV MANUFACT_COM_GO MANUFACT_COM_LRN	2000 2001 2010 2011 2012 2013 2014 2015 2016 2017 2018 2019 2020 2050 2051 2052 2053

Continued

Index (hex)	Object	Used	
		PDO mappable parameters (2080 - 2093):	
		MANUFACT_POS	2080
		MANUFACT_ABS_POS	2082
		MANUFACT_VEL	2081
		MANUFACT_VEL_COMMAND	2090
		MANUFACT_CONTROL_COMMAND	2091
		MANUFACT_TORQUE_COMMAND	2092
		MANUFACT_POS_COMMAND	2093
		Read only:	
		MANUFACT_COM_ACTU	2100
		MANUFACT_COM_ACTV	2101
		MANUFACT_COM_ANAIN	2102
		MANUFACT_COM_CUR	2103
		MANUFACT_COM_FLT	2104
		MANUFACT_COM_FEST	2105
		MANUFACT_COM_LOG	2106
		MANUFACT_COM_MODE	2107
		MANUFACT_COM_MPFE	2108
		MANUFACT_COM_MVFE	2109
		MANUFACT_COM_PFE	210A
		MANUFACT_COM_VFE	210B
		MANUFACT_COM_POS	210C
		MANUFACT_COM_PREF	210D
		MANUFACT_COM_RFOFS	210E
		MANUFACT_COM_VEL	210F
		MANUFACT_COM_VREF	2110
		MANUFACT_COM_WRN	2111
		MANUFACT_COM_ABSPOS	2112
		Write only:	
		MANUFACT_COM_CLEAR	2180
		2180 MANUFACT_COM_DIS	2181
		MANUFACT_COM_ENA	2182
		MANUFACT_COM_DISA	2183
		MANUFACT_COM_FRST	2184
		MANUFACT_COM_GRST	2185
		MANUFACT_COM_HOLD	2186
		MANUFACT_COM_IADJ	2187
		MANUFACT_COM_ICLC	2188
		MANUFACT_COM_JS	2189
		MANUFACT_COM_LOGRST	218A
		MANUFACT_COM_PRST	218B
		MANUFACT_COM_ABS	218C
		MANUFACT_COM_HOME	218D
		MANUFACT_COM_INC	218E
		MANUFACT_COM_CALC	2190
		MANUFACT_COM_QUIT	2191
		MANUFACT_COM_CONT	2192
		MANUFACT_COM_STOP	2193
		MANUFACT_COM_PLOAD	2194
		MANUFACT_COM_PSAVE	2195
6000 - 9FFF	Standardized Device Profile Area		
A000- FFFF	Reserved		

Subindexes to Index 2010 (CUR. Commands)

ASCII Command	Subindex	Read/Write (RW), Read only (RO), Write only (WO)
(Entries)	0x00	RO
CUR.ACTV	0x01	RO
CUR.ACTU	0x02	RO
Reserved	0x03	
CUR.IPEAK	0x04	RW
CUR.INOM	0x05	RW
Reserved	0x06	
Reserved	0x07	
Reserved	0x08	
CUR.TOFR	0x09	RW
CUR.TOSH	0x0A	RW
CUR.BEMF	0x0B	RW
CUR.SCAL	0x0C	RW
CUR.VOLT	0x0D	RW

Subindexes to Index 2011 (VEL. Commands)

ASCII Command	Subindex	Read/Write (RW), Read only (RO), Write only (WO)
(Entries)	0x00	RO
VEL.ACC	0x01	RW
VEL.ADZON	0x02	RW
VEL.BW	0x03	RW
Reserved	0x04	
VEL.MXRPM	0x05	RO
VEL.VEL	0x06	RO
Reserved	0x07	
VEL.VREF	0x08	RO
VEL.CTRL	0x09	RW
VEL.TRKFCT	0x0A	RW
VEL.GV	0x0B	RW
VEL.GVI	0x0C	RW
Reserved	0x0D	
Reserved	0x0E	
Reserved	0x0F	
VEL.INRT	0x10	RW
VEL.SCAL	0x11	RW
VEL.VOLT	0x12	RW

Subindexes to Index 2012 (HW. Commands)

ASCII Command	Subindex	Read/Write (RW), Read only (RO), Write only (WO)
(Entries)	0x00	RO
HW.GRFX	0x01	RW
HW.GRSH	0x02	RW
HW.PLCGEAR	0x03	RW
HW.RES	0x04	RW
HW.TYPE	0x05	RW

Subindexes to Index 2013 (POS. Commands)

ASCII Command	Subindex	Read/Write (RW), Read only (RO), Write only (WO)
(Entries)	0x00	RO
POS.FEWRN	0x01	RW
POS.FEFAT	0x02	RW
POS.FEST	0x03	RO
POS.FFA	0x04	RW
POS.FFTYPE	0x05	RW
POS.FFV	0x06	RW
POS.IPOS	0x07	RW
POS.KP	0x08	RW
POS.MPFEE	0x09	RO
POS.REF	0x0A	RO
POS.PFE	0x0B	RO
POS.POS	0x0C	RO

Subindexes to Index 2014 (MTR. Commands)

ASCII Command	Subindex	Read/Write (RW), Read only (RO), Write only (WO)
(Entries)	0x00	RO
MTR.IDX	0x01	RW
MTR.IND	0x02	RW
MTR.INOM	0x03	RW
MTR.IPEAK	0x04	RW
MTR.JM	0x05	RW
MTR.MPLS	0x06	RW
MTR.RPLS	0x07	RW
MTR.RES	0x08	RW
MTR.KT	0x09	RW
MTR.KV	0x0A	RW
MTR.NAME	0x0B	RW

Subindexes to Index 2015 (DRV. Commands)

ASCII Command	Subindex	Read/Write (RW), Read only (RO), Write only (WO)
(Entries)	0x00	RO
DRV.BUSAPP	0x01	RW
DRV.BUSOV	0x02	RW
DRV.BUSV	0x03	RW
DRV.I2T	0x04	RW
DRV.ID	0x05	RW
DRV.IDX	0x06	RW
DRV.INOM	0x07	RW
DRV.IPEAK	0x08	RW
DRV.LIFE	0x09	RO

Subindexes to Index 2016 (SYS. Commands)

ASCII Command	Subindex	Read/Write (RW), Read only (RO), Write only (WO)
(Entries)	0x00	RO
SYS.ANAIN	0x01	RO
SYS.ANA2	0x02	RO
SYS.ENC	0x03	RW
SYS.ENCRESES	0x04	RW (encoder system only)
SYS.FAULT	0x05	RO
SYS.FBACK	0x06	RW
SYS.INFO	0x07	RO
SYS.MOD	0x08	RW
SYS.OPT	0x09	RO
SYS.POWER	0x0A	RO
SYS.RFOFS	0x0B	RW
SYS.POS	0x0C	RO
SYS.STTS	0x0D	RO
SYS.VER	0x0E	RO
SYS.WRN	0x0F	RO
Reserved	0x10	
SYS.ENCINDX	0x11	RW
SYS.LEVEL	0x12	RO

Subindexes to Index 2017 (JOG. Commands)

ASCII Command	Subindex	Read/Write (RW), Read only (RO), Write only (WO)
(Entries)	0x00	RO
JOG.TIME	0x01	RW
JOG.TYPE	0x02	RW
JOG.VEL	0x03	RW

Subindexes to Index 2018 (MOT. Commands)

ASCII Command	Subindex	Read/Write (RW), Read only (RO), Write only (WO)
(Entries)	0x00	RO
MOT.ABSPOS	0x01	RO
MOT.ACC	0x02	RW
MOT.VEL	0x03	RW
Reserved	0x04	
MOT.TYPE	0x05	RW
MOT.DWELL	0x06	RW
MOT.INCCW	0x07	RW
MOT.INCW	0x08	RW
MOT.SRC	0x09	RW
MOT.STATUS	0x0A	RO
MOT.TRIG	0x0B	RW
MOT.BUFTYPE	0x0C	RW
MOT.GENPOS	0x0D	RO

Subindexes to Index 2019 (HOM. Commands)

ASCII Command	Subindex	Read/Write (RW), Read only (RO), Write only (WO)
(Entries)	0x00	RO
HOM.ACC	0x01	RW
Reserved	0x02	
HOM.VEL	0x03	RW
HOM.TYPE	0x04	RW
HOM.OFFSET	0x05	RW
HOM.POLR	0x06	RW
HOM.STATUS	0x07	RO

Subindexes to Index 2020 (LIM. Commands)

ASCII Command	Subindex	Read/Write (RW), Read only (RO), Write only (WO)
(Entries)	0x00	RO
LIM.CW	0x01	RW
LIM.CCW	0x02	RW
LIM.ON	0x03	RW
LIM.LRN	0x04	RW

Appendix A

Manual Tuning

TUNING

This appendix presents guidelines for manual tuning the Control. Tuning is necessary, since a various loads (friction and inertia) will effect the drive response. Response may be defined as the time required for the drive to reach speed.

Various software “tools” are available to make tuning easier, such as:

Internal libraries (easy definition of parameters),

pole placement (the software calculates a “no-overshoot” response),

plotting routine (the drive response is displayed on a screen).

This information is as a guide only and the exact response is entirely up to the individual performing the tuning.

TUNING GUIDELINES

The Flex control is easily tuned using a laptop computer and Flex software. The autotuning procedure provides a stable and responsive drive, by adjusting the parameter values for velocity loop tuning. The autotuning procedure will work for most applications. Manual tuning however may be desirable when very tight response is required. These guidelines provide a basic reference starting point for any additional adjustments.

General Tuning Rules

Tune the velocity loop first, and then tune the position loop (when using pulse/direction, or position follower mode). The velocity loop should always be tuned before the position loop, as velocity loop tuning affects the position loop response. To reduce mechanical resonance, use a stiffer mechanical coupling or decrease the low-pass filter value.

Manual Tuning

Manual tuning may be used to adjust the response of the control. Two types of manual tuning are possible: velocity tuning and position tuning (for a system which has been set up to operate in either the pulse/direction, or position follower mode).

Initial Settings Required

Before manual tuning can begin, the motor, control, and operating mode must be set. Make sure that these parameters have been selected and downloaded.

There are 7 parts to the setup procedure:

Motor

Select your motor from the library. First, select the general motor type. Then select your specific motor. All of the parameters will be entered if your motor is on the list. If your motor is not on the list, you may define a motor and all of its parameters. Click “Download” when finished.

Figure A-3 Motor Selection Screen



Control

The “Control ID” is automatically selected. All of the parameters will be entered if your control is on the list. Click “Download” when finished.

Figure A-4 Control Selection Screen



After the motor and control are selected, click the General menu and note that the values are filled in.

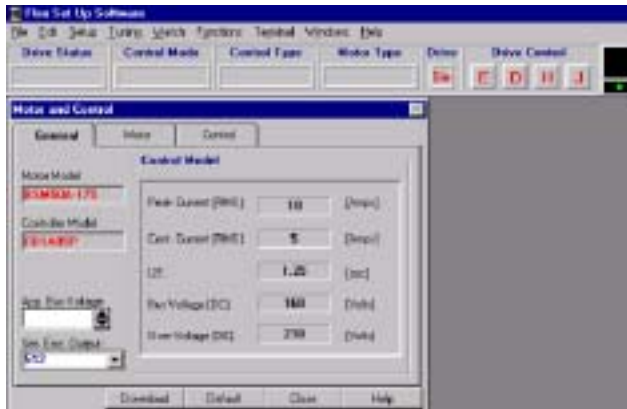

Operating Mode

Select the operating mode of the control. Choices are:

1. Current Mode
2. Velocity Mode
3. Pulse Follower Mode (Pulse & direction or Electronic Handwheel)
Click "Download" when finished.

Figure A-5 Operating Mode Selection Screen



Current Parameter

Nominal and peak current values are automatically entered for the motor type. For manual tuning only, set the control current limit value to a percentage of the continuous current rating. For example, if your control is rated for 5A continuous current and you desire to limit the output current to 4A, enter 80%. If you wish to use the full output power of the control, enter 100%. Click “Download” when finished.

Figure A-6 Current Parameter Screen



Velocity Parameter

Set the velocity parameters of the control:

1. Scale factor - ratio of the input voltage to output RPM.
2. Minimum velocity
3. Time to maximum velocity

Click “Download” when finished.

Figure A-7 Velocity Parameter Screen



Drift

If you know the input offset value of the control, you may enter the value manually. Otherwise, you may initiate automatic offset tuning and let the control measure and set this value. Click "Download" when finished.

Figure A-8 Drift Parameter Screen



Manual Tuning The first six steps of the manual tuning process is shown in Figure A-9.

Figure A-9 Select Manual Tuning

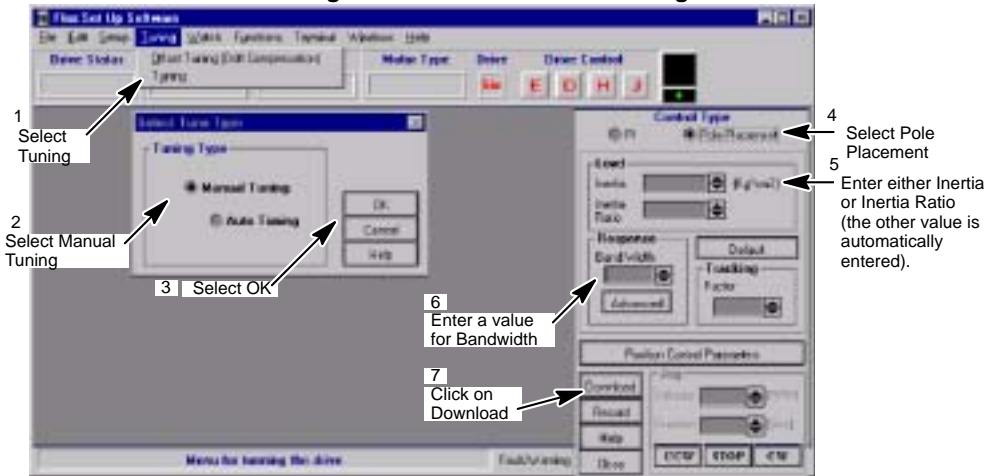

If "Pole Placement" method of adjustment is selected, you would enter values for "inertia" or "inertia ratio". Enter either one, and the other value will automatically be entered. This is the easiest and recommended method of adjustment.

If "PI" method of adjustment is selected, you would enter values for GV-gain and GVI-gain. This is an advanced method of adjustment, and is more difficult.

Both methods of adjustment provide identical results. PI method is described later in this section.

POLE PLACEMENT

Pole placement provides a “no-overshoot response” when tuned for the correct inertia. This is the easiest and recommended method of adjustment.

Inertia

Click in the “Load” block and enter the value in Kg-cm². The range is from 0 to 133 Kg-cm².

If the inertia is under-estimated, the system will be stable. If the inertia is over-estimated, the system will vibrate or oscillate due to too much system gain. If the load inertia is unknown, estimate low. It is recommended to start with “load inertia = 0.2”, which represents a stable condition.

If you entered the “inertia ratio”, you should enter a value representing the ratio of reflected load inertia to motor inertia. The range is from 0 to 100.

Response

Move to the “Response” block and place the cursor in the “bandwidth” window, and click on it.

The “bandwidth” is a measure of the range over which the system can respond. It is expressed in frequency or Hertz. This parameter controls the “rise time” of the system. It does not effect overshoot.

It is recommended that bandwidth is increased only if higher dynamic response is required. Increase the bandwidth and observe (go to plotting of move) the “velocity” and “command current”, until current reaches maximum value, then back off to 80%. The range is from 10–200.

The next step, would be to verify that the value you entered, provides for adequate system response. You can check this out, by having the software move the equipment and plot the response. Proceed to “Plotting of Move”.

Figure A-10 Inertia and Load Response Examples

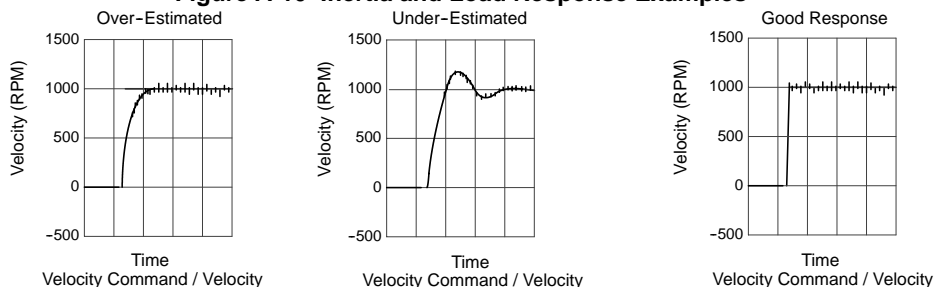

Tracking factor

The tracking factor parameter controls the amount of tracking versus overshoot.

The range is 0 to 200. A “tracking factor” of “0” generates no overshoot. A “tracking factor” of 200 results in a PI equivalent control (i.e. with overshoot).

The next step, would be to verify that the values you entered, provides for adequate system response. You can check this out, by having the software move the equipment and plot the response. Proceed to “Plotting of Move”.

Click in the “Tracking” block and enter the desired adjustment value. This adjustment is used for applications that require improved tracking (or following) capability, to improve (or reduce) following error.

PI COMPENSATION

PI method of adjustment allows adjustment of the acceleration ramp time and overshoot values. If “PI” Compensation is selected, you would enter values for GV-gain and GVI-gain. Select PI Compensation instead of Pole Placement on the menu shown in Figure A-9.

This is an advanced method of adjustment for use by servo engineers. The “pole placement” method is easier to use for most applications and is recommended.

Figure A-11 PI Compensation Menu



GVI-Gain

The “Integral Gain (GVI)” is the “integral gain” of the velocity loop. It controls 1) the stiffness (the ability to reject load disturbances), and 2) the amount of offset, or following error, during steady state conditions (velocity command or load does not change). The adjustable range is from 0 to 32767.

1. Click on the “Integral Gain (GVI)” box and enter a value. You may want to begin with the default values – click on the “default” button and answer “yes. To increase stiffness, increase the GVI-gain setting. It rejects load disturbance and compensates for system friction.

To reduce following error, or offset, during steady state running conditions, increase the GVI-gain setting. To reduce the overshoot, reduce the GVI-gain setting.

Note: As you increase the value for GVI, the system will become unstable, i.e. oscillate. You may hear an audible noise. Decrease the GVI value immediately. Continue to decrease the value until the noise is no longer heard, then decrease it another 10%.

2. Next, verify that the value you entered provides adequate system response. To verify, have the software move the equipment and plot the response. Proceed to “Plotting of Move”.

GV-Gain

This is the “proportional gain” of the velocity loop. It controls the gain of the velocity loop by adjusting the controls response to the error. The error is the difference between the commanded and actual velocity. The higher the gain, the smaller the difference (or error). The adjustable range is from 0 to 32767.

1. Click in the “Proportional Gain (GV)” box. Enter a value for GV. You may want to begin with the default values – click on the “default” button and answer “yes”.

Note: The default values may not be best for all applications, it may be too high. If the system is noisy (displays an audible noise) decrease this value immediately.

To obtain a faster rise time, increase the GV-gain setting. The ramp up time (to operating speed) will be faster. As you increase the value for GV, the system may have very large overshoots and become unstable. Decrease the GV value immediately. Then decrease it another 10%.

2. Next, verify that the value you entered provides adequate system response. You can check this out, by having the software move the equipment and plot the response. Proceed to “Plotting of Move”.

Plotting of Move

At any time after the setup parameters are downloaded to the control, you may proceed to the plotting routine. Plot allows you to verify that the parameter values you entered provide adequate system response.

In this section, you will inform the software what move to perform. You will enter time (for the move), direction (CW or CCW) and speed. It is recommended that you start with low speeds (i.e. 100 RPM) and short time periods (i.e. 0.5 sec) until you get a feel for your system.

Control Window

Enter the parameter values using the Pole Placement menu and click the “Download” button. Refer to Figure A-9 for details.

Figure A-12 Record & Plot Menu

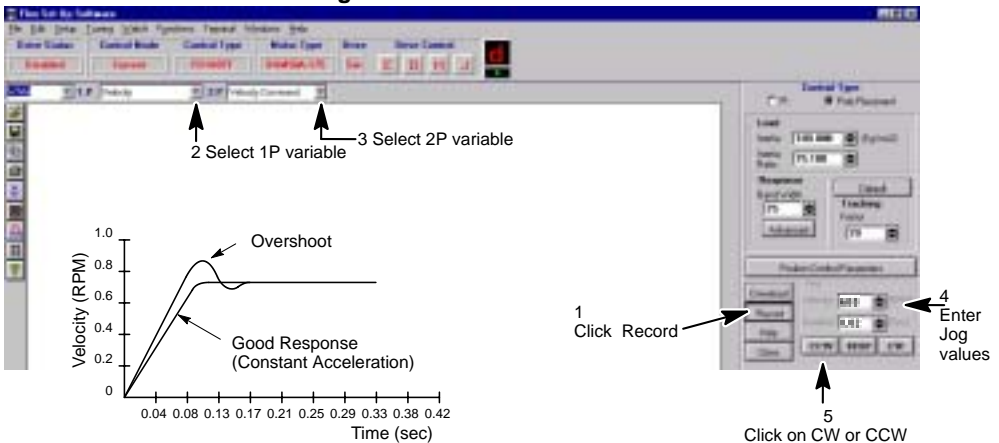

Graphic Screen

Click on the “Record” button to activate a graphic screen.

Move the cursor to the “plot variable” window (1P and 2P windows = 1st and 2nd Plot windows) and choose one or two variables which will be drawn on the plot (such as velocity, velocity command, etc.).

Jog Block

Click on “velocity” in the Jog window. Enter a value to run the motor. A low speed (i.e. 100 RPM) is recommended.

Click on “duration” in the Jog window. Choose a duration time. Recommend that you use a short time period (i.e. 0.5 sec).

Initiate Move

Click on either the “CW” or “CCW” button. This selects the direction of movement and the software will plot the variables you selected. Observe the performance plot. If it meets your expectations, you are done. If you wish to alter parameters and view another plot, repeat the above procedure.

Pulse Follower Applications (Only used in “pulse follower” applications).

Choose Tuning

Select the “Manual tune” method as shown in Figure shown in Figure A-9.

Position Parameters

Click on the “Position Parameters” button. You will see parameters as shown in Figure A-13. Selecting “None Feedforward” allows you to enter Position Gain.

Figure A-13 Position Control Menu



Select Velocity feedforward allows you to enter Position Gain and Velocity, a parameter that is proportional to the desired velocity. Increasing this gain, compensates for damping (brings actual velocity closer to desired velocity). It is not within the servo loop, so it does not effect stability. The adjustable range is from 25 to 100%.

Select Acceleration feedforward allows you to enter Position Gain and Velocity and Acceleration. Acceleration is a parameter that is proportional to the desired acceleration. Increasing this gain, compensates for inertia (brings desired acceleration closer to actual acceleration). It is not within the servo loop, so it does not effect stability. Inertia resists acceleration. The adjustable range is from 25 to 100%.

Initiate Move

To verify that the parameter values are correct, you must cause the system to move. This would be accomplished by having the “host controller”, or “indexer”, or “computer” output a string of pulses.

During movement, observe the “Monitor” (7-segment display) on the front panel.

If a “P” is observed on the Monitor display, the drive is within the “in-position” band which has been set. If a “P” is not observed, then the drive is outside the band, or window. This would occur, for example, with a high friction system.

Either the gain or feedforward term must be adjusted, or the “in-position” band must be opened (until a “P” is observed).

Note: To change the “in-position” band or window, you have to choose Setup (from the “toolbar” at top of the screen). In the box, choose “Operation Mode”. You will see choices of “general”, “current”, “velocity”, and “pulse”. Select “pulse” tab. This will open the window showing the “following error limits”. You may enter and modify (open) the in-position bands.

Appendix B

Command Set

Flex - ASCII - Command - Set

General

Flex controls use the RS232 communication port (optional RS485) as the Interface. This document describes existing FlexDrive/Flex+Drive ASCII terminal commands for setup and control of the servo drive.

There are three types of ASCII commands:

1. Parameters. Without parameters, these commands are handled as queries. To modify the value of a parameter, the value to be set is added to the command. Some parameters may only be modified under special drive conditions. Query is not restricted to special drive conditions.
2. Variables or system constants. System variables are internally updated in the control, and can not be changed by the user. System constants are fixed (e.g. by hardware) system properties. Query of variables or constants is not restricted to special drive conditions.
3. Methods support control of the system. Methods may or may not require a parameter. Commanding a method to be executed is in some cases also restricted to special drive conditions. Each command is defined as a special mnemonic, which is used for query of parameters, variables and constants as well as for parameter less methods. Modifying a parameter respectively commanding a parameterized method is done by simply adding the parameter value to the mnemonic.

Syntax

General structure of the ASCII command

Each ASCII command is structured in principle according to "Mnemonic" "Delimiter" "Parameter List". Syntax allows multiple commands in the same string separated by blank space delimiter. Each command string is terminated by a carriage return. i.e. generally, a command string looks like:

"Mnemonic1" "Delimiter" "Parameter List1"... "MnemonicN" "Delimiter" "Parameter ListN" [CR]

Up to 80 characters are allowed at the command prompt.

For each correct command the control returns a ">" sign (ASCII 3E hex) as an acknowledgement. If a command is not accepted, the reason for the command revision is sent instead of the acknowledgement.

Mnemonics

The mnemonics are not case sensitive. Most of the ASCII commands are grouped into functional groups. The Mnemonics of the commands of parameters, variables and methods of these function groups have a prefix, which indicate the function and, separated by the dot, the command identifier. The general structure of Function Group Commands is as follows:

"Functional Group"."Command Identifier" "Delimiter""Parameter list" [CR].

e.g.SYS.MOD 1

All prefixed commands are drive parameters. The delimiter between mnemonic and parameter of these commands is either blank space or equal sign (one of both is mandatory). To query all parameters and variables of a function group, the function group prefix followed by dot and asterisk can be used:

"Functional Group".*

e.g.SYS.*

Upon receiving a command, the controller answers by sending the function parameter and variable list. General purpose commands are not prefixed. These commands only consist of the command identifier and therefore need the general structure

"Command Identifier" ["Delimiter"]"Parameter list" [CR]

With the non-prefixed commands, no delimiter is mandatory, but the blank space can be inserted optional.

Parameters and Units

The parameters used within the ASCII commands are integers of different sizes:

INTEGER: 16 bit value ranged 8000.. 7FFF hex (-215.. +215-1 dec.)

UNSIGNED INT: 16 bit value ranged 0.. FFFF hex (0..216-1 dec.)

LONG: 32 bit value ranged 80000000.. 7FFFFFFF hex (-231.. +231-1 dec.)

UNSIGNED LONG: 32 bit value ranged 0.. FFFFFFFF hex (0.. +232-1 dec.)

STRINGS: Strings of ASCII characters (0 .. FF hex).

A string parameter is preceded and terminated with double quote character (")!

Commands, which accept or require more than one parameter, use parameter lists which are composed of the sequence of parameters necessary, with the delimiters blank space or comma between.

The number of the parameter can be given as decimal value or as hexadecimal value. Hexadecimal values are preceded by one or more 0-character (30 hex), while decimal values are taken as default without indicator.

The ASCII command set description below, also shows the units of the parameters respectively indicate parameters with no units. For best resolution within the accepted range, the units of the parameters are not chosen according to SI, but most of the units used are SI units multiplied with potentials of 10.

In some cases, units are related to system properties and can therefore not be same for all applications. The following is an example of how to calculate Counts and Limits, used with positioning and homing:

Resolver			
max.	RPM Resolution	Counts/rev.	Limits
< 1500	216	216	± 229-1
< 6100	214	216	± 229-1
< 6100	212	216	± 229-1

Encoder			
Pulses/rev.	Resolution	Counts/rev.	Limits
1000	4000	64000	225-1
1500	6000	48000	226-1
2000	8000	64000	226-1
2500	10000	40000	227-1
5000	20000	40000	228-1
6000	24000	48000	228-1

The resolution of all (Resolver or Encoder) is between ± 213 and ± 214.

Start-up with Terminal Communication and Command Examples

1. Select the correct COM port NR. and set the following at your PC:
 - Baud Rate: 9600
 - Protocol (Hardware, Xon/Xoff, None): OFF
 - Data Length: 8 Bit
 - Stop Bit: 1
 - Parity: NONE
2. Set the control address. The address is set by switch AS1-1 to AS1-4. To locate a control, type "A" then the control address, e.g. **A3** (searches for a control with address 3). If a drive with address "3" is running and connected to the PC COM, this drive answers with the prompt sign ">" to indicate that communication to the drive is established. Additional command may be sent to the A3 control.

Entering an address command with another address number, will terminate communication with control A3. If more than one drive is connected to the PC COM port, typing the address of another drive connected, will change communication path to this one.
3. Communication is now established and the ASCII commands may be used.

Note: If more than one drive is connected to the PC port, correct communication can only be established if all drives have different addresses.

4. **Error messages** (from the control)

If the syntax and the values of the ASCII command string are correct, the control accepts the command and answers by sending "<" as acknowledge. If any error within the transferred command was found, the control rejects the command by sending a correlated error string. There are following terminal-reported errors :

 - **SYNTAX ERROR**: invalid character;
 - **EXECUTION ERROR**: invalid command;
 - **RANGE ERROR**: invalid parameter value;
 - **INVALID EXE CONTEXT**: invalid command or operation mode;
 - **control DESIGN FAILURE**: invalid control design;
 - **INPUT BUFFER OVERFLOW**: command line exceeded 80 char.;
 - **TOO MANY PARAMETERS**: too many parameters;
 - **REQ. PARAMETER MISSED**: not enough parameters;

In case of an error, the event protocol will return a NAK (negative acknowledge) to a user. The error check can only provide a syntax and range check for each command. Error checking will not check a wrong parameter value that may degrade system performance.

General Settings

System Constants

Command	Description	Range	Common	Lev I	LevII
SYS.POWER	Queries dip switch ID, (see DRV.ID)		X		
SYS.FBACK	Queries system feedback (encoder / resolver) as defined by ALTERA	0:1	X		
SYS.INFO (SYS.VER)	Queries firmware version with naming and version number as ASCII string	ASCII letters	X [1]		
SYS.LEVEL	Queries level version	1 : 2	X [2]		
SYS.OPT	Queries ALTERA option(s)X	0 : 7	X		
SYS.STTS (COM.ADDR)	Most Significant-Word of SYS.STTS gives control address of (LS-Word s. below). Control Address is set per Dip Switch	(MS-Word of SYS.STTS)			

- [1] Firmware versions RES-1.xx, ENC-1.xx SYS.VER is equal to SYS.INFO , downward versions: answer to SYS.VER is unsigned integer version number only
- [2] Firmware versions RES-1.xx, ENC-1.xx only (no version)

Basic System Parameters

Motor Parameters (MTR. prefixed)

Command	Description	Units	Range	Default	E ² / Par. set
MTR.IDX	D3S/FlexDrive/Flex+Drive Setup library defined Motor Index		Unsign Int.		E / P
MTR.IND	Motor inductance	0.01 H	1 : 65535		E / P
MTR.INOM	Motor nominal current	0.1 A	1 : 65535		E / P
MTR.IPEAK	Motor peak	0.1 A	1 : 65535		E / P
MTR.JM	Motor Inertia	0.01 Kg-cm ²	1 : 65535		E / P
MTR.MPLS	Motor number of poles		1 : 65535		E / P
MTR.RES	Motor resistance	0.01 Ohm	1 : 65535		E / P
MTR.KT	Motor torque constant (torque to RMS phase current)	0.001 Nm/A	1 : 65535		E / P
MTR.KV	Motor bmf constant	V/1000RPM	1 : 65535		E / P
MTR.NAME	Motor string name in ASCII characters		ASCII char		E / P

Drive Parameters (typical DRV. prefixed)

Command	Description	Units	Range	Default	E ² / Par. set
DRV.BUSAPP	Application bus voltage	V	Unsign. Int.		E / P
DRV.BUSOV	Application bus over voltage	V	Unsign. Int.		E / P
DRV.BUSV	Drive Bus voltage	V	Unsign. Int.		E / P
DRV.I2T	I2t warning time	0.01 s	100 : 300		E / P
DRV.ID	Drive ID (EEPROM value) to be checked against power ID (dip switch) in case of Version Error ("U")		Unsign. Int.		E / P
DRV.IDX	FlexDrive/Flex+Drive Setup library index		Unsign. Int.		E / P
DRV.INOM	Drive nominal current	0.1 A	Unsign. Int.		E / P
DRV.IPEAK	Drivepeak current	0.1 A	Unsign. Int.		E / P

Additional System parameters (mostly SYS.* prefixed)**Velocity Feedback Parameters:**

Command	Description	Units	Range	Default	E ² / Par. set
MTR.RPLS	Resolver number of poles	-	1 : 65535		E / P
SYS.ENCREC	Queries / updates encoder feedback resolution for encoder motors (in pulses per revolution, i.e. before quadrature)	pulses/rev.	1 : 16384		E / P
SYS.ENCTBL	Queries encoder motor hall table type.	-	0 : 2		E / P

Firmware versions RES-1.xx, ENC-1.xx only Encoder Simulation Output Parameter:

Command	Description	Units	Range	Default	E ² / Par. set
SYS.ENC	Encoder simulation resolution. Range depends on maximum velocity (VEL.MXRPM) Up to 1500 RPM: 512 :4096; above 1500 RPM: 512 only. Downward versions to 80112d1000, (incl.) also provide the decimal values.	Puls/Rev.	512 : 1024 (2048 : 4096) (500, 1000 1250, 1500)		E /

Software Limit Switches Parameters:

Command	Description	Units	Range	Default	E ² / Par. set
LIM.CCW	Absolute Position of Software Limit Switch CCW (related to1 Home, activated after Homing only)	Counts 1	-Limit:Limit 1	0	E /
LIM.CW	Absolute Position of Software Limit Switch CW (related to1 Home, activated after Homing only)	Counts 1	-Limit:Limit 1	0	E /
LIM.ON	Deactivate / activate Software Limit Switches (independent from Hardware Limit Switches)	-	0 (off) 1 (on)	0	E /
1 Counts and Limits depend on Resolver and Encoder resolution					

Variables: NONE

Software Limit Switches Methods:

Command	Description	Parameter	Units	Range
LIM.LRN	Take actual position as software limit for CW respectively CCW	0: CW 1: CCW	-	0 : 1

PLC Parameters:

Command	Description	Units	Range	Default	E ² / Par. set
PLC.LINE	<p>Defines PLC statement :IF [input]=TRUE, THEN [action] set/started, with syntax PLC.LINE [num] [action] [input] [num] [action] - PLC line number, and string parameter for PLC action, fixed to line number:</p> <p>0 "ENABLE" (PLC enable) 1 "MAO1" (Digital Input MAO1) 2 "MAO2" (Digital Input MAO2) 3 "MAO3" (Digital Input MAO3, if available) 4 "MAO4" (Digital Input MAO4, if available) 5 "RELAY" (6 "USRERR" (Error "9") 7 "FRST" (Fault Reset) 8 "DISA" (Disable active, s. 0) 9 "DISP" (Disable active, s. 0) 10 "HOLD" (Hold-status, s. 0) 11 "JOG" (JOG function, s. 0) 12 "GEAR" [input] - string parameter with enumerated values:</p> <p>"FALSE": Always false, i.e. switched off "CW", "CCW": Hardware or Software Limit Switches "MAI1", "MAI2": Digital Inputs "MAI3", "MAI4": Digital Inputs (if available) "DRVOT", "MTROT": Drive respectively motor overtemperature "I2tWRN": I²T-warning (error "7") "TRUE": Always true, i.e. switched ON "INPOS", "FEWRN", "FEFAT": Flags of Position Controller in position, following error warning, following error limit (s. 0) BADMOV: Not initialized motion buffer line commanded (s. 0) "MOTRDY", "MOTNRDY": Positioning finished respectively in process</p>	<p>num: 0 : 12 action: s. left lines: input: s. left lines:</p>	<p>PLC disabled, all lines: input = false</p>		E / P

Note: Choice of Inputs and Outputs is not completely available in all configurations

Variables: NONE

PLC Methods:

Command	Description	Parameter	Units	Range
PLC	<p>Enables ("on") / disables ("off") / clears and disables ("clr") PLC. PLC on and off command is stored in PLC buffer line 0.</p>	"on", ("off"), "clr"		

OCI Interface Parameters:

Command	Description	Units	Range	Default Significant	E ² / Par. set
CAN.BD	(The range check is: Invalid execute context.) It should be: "Range error"	Hz	10 : 1000	OK	
CAN.ID	(The range check is: Invalid execute context.)	-	1 : 127	OK	

Digital Interface Parameters:

Command	Description	Units	Range	Default	E ² / Par. set
MOT.INCCW	Defines digital Input CCW/MAI4 as CCW (0) or as MAI4 (1) for positioning	-	0 : 1	0	E / P
MOT.INCW	Defines digital Input CW/MAI3 as CW (0) or as MAI3 for positioning	-	0 : 1	0	E / P

Analog Interface Parameters:

Command	Description	Units	Range	Default	E ² / Par. set
SYS.RFOFS (RFOFS)	Query / updates system reference offset of the analog input, with analog input range $\pm 10V$ (RFOFS only supports query)	mV	-100000 : 100000	0	E / -

Note: Scaling of the analog input command is offered with firmware versions RES-1.xx, ENC-1.xx. Because scaling parameters are different for current mode and velocity mode, these parameters are described under 0 (current command scaling) respectively 0 (velocity command scaling).

System Variables

General Variables:

Command	Description	Units	Range	Default	E ² / Par. set
DRV.LIFE	Drive life time.	Hrs	Unsign.Word		E / -
SYS.STTS	Queries system status as a double word, where Word High word is drive address (set by Dip switches) Low word: bit array "OR"ed with system status: 0x0001: Disable SW 0x0002: Disable HW 0x0004: CW 0x0008: CCW 0x0010: Fault exists 0x0020: Warning exits 0x0040: Hold mode 0x0080: Burn in Status 0x0100: Jog Status 0x0200: Enable 0x0400: Jog Non Zero Velocity 0x0800: n/a 0x1000: HW source for Disable HW: 0x2000: PLC active	-	Long Word		- / -

Queries / modifications of Fault Listing Variables:

Command	Description	Units	Range	Default	E ² / Par. set
FAULT	Gets system fault string list, response is multiple string X1	-			- / -
FLT	Gets system fault string list, response is error numberX1	-	X1		- / -
LOG, LG	Gets system fault log list X1	-	X1		- / -
LG	Gets system fault log number list X1	-			- / -
WRN	Gets system warning list as multiple strings	-			- / -
SYS.FAULT	Queries system fault as ID of the most significant fault	-			- / -
SYS.WRN	Queries system warnings. The most important warning will be reported as ID	-			- / -

X1 Possible Faults

X1 Fault	Display	Description
1	"USER ERROR"	PLC user generated error. Displays '9'.
2	"OVERCURRENT"	Over current. Displays '3'.
3	"OVERVOLTAGE"	Bus over voltage. Displays '1'.
4	"FEEDBACK"	Resolver/encoder position feedback error. Displays '5'.
5	"POWER_FAIL"	Power fail. Displays '2'.
6	"BPS"	BPS fail. Displays '2'.
7	"OVER_15_VOLTAGE"	±15v over voltage. +15v line is more then 17v or -15v line is more than -17v. Displays '4'.
8	"UNDER_15_VOLTAGE"	±15v under voltage. +15v line is less then 12v or -15v line is less than -12v. Displays '4'.
9	"EEPROM_ERROR"	N.I
10	"EPROM_ERROR"	N.I
11	"RAM_ERROR"	RAM integrity error. Displays '9'.

X1 Possible Faults - Continued

X1 Fault	Display	Description
12	"FAULT_RELAY"	when fault relay is closed. Displays '9'.
13	"EAF"	N.I
14	"MISSING INT"	N.I
15	"POWER_ID"	DRV.ID != SYS.POWER. Displays small 'u'.
16	"CW_CCW"	Both limit switches are on. Displays 'L'.
17	"DESIGN_FAILURE"	Control design fail. Displays small 'c'.
18	"EE_CLEARED"	EEPROM header stamp was not detected. Displays 'U'
19	"EE_INTEGRITY"	EEPROM footer stamp was not detected. Displays 'A'.
20	"EAF Drive Temp"	EAF drive over temperature error. Displays '6'.
21	"EAF Motor Temp"	EAF motor over temperature error. Displays '6'.
22	"EAF Drive I2T"	EAF drive I ² T error. Displays '6'.
23	"EAF Motor I2T"	EAF motor I ² T error. Displays '6'.

Methods:

Command	Description	Parameter	Units	Range
FRST	Resets system faults if allowed. Reset is not allowed, if error is still pending.	-	-	-
LOGRST	Resets system fault log	-	-	-

Communication Settings

Parameter:

Command	Description	Units	Range	Default	E ² / Par. set
ECHO	Disable / enable echoing for input characters	-	"ON/OFF"	"ON"	- / -
PROMPT	Enables / disables terminal prompt	-	"ON/OFF"	"ON"	- / -
TALK	Enables / Disables terminal error notification	-	"ON/OFF"	"ON"	- / -

Variable:

Command	Description	Units	Range	Default	E ² / Par. set
COM.STTS	Queries the most recent communication handler error	-	0:65535		- / -

Methods:

Command	Description	Parameter	Units	Range
B	Opens communication to the drive, called by its address (the addresses a constant, which can be queried by COM.ADDR or SYS.STTS)	Address	-	0 : 7

Queries of System Variables, Status, Faults

Single Values:

Command	Description	Units	Range	Default	E ² / Par. set
ACTU CUR.ACTU	Query for actual current U	0.01 A			- / -
ACTV CUR.ACTV	Query for actual current V	0.01 A			- / -
ANAIN SYS.ANAIN	Query for analog input	mV			- / -
POS, RPOS,	Queries motor position				- / -
SYS.POS POS.POS	Resolver bits / encoder counts				- / -
VEL VEL.VEL	Query feedback velocity	RPM			

Data Record (REC. prefixed) Parameters:

Command	Description	Units	Range	Default	E ² / Par. set
REC.GAP	Specify gap between recording samples in number of servo loops (0.5 ms)	-	0 : 65535	1	E / -
REC.TIME	Specify recording time	0.5 ms	1:65535	1000	- / -
REC.VAR1, REC.VAR2	Specify recording variable: "POS": position, "REF": velocity command, "VEL": velocity, "CUR": current command, "ACTU": current U, "ACTV": current V, "FE": position following error.	-	s. left	"POS" "VEL"	- / -

Data Record (REC. prefixed) Variable:

Command	Description	Units	Range	Default	E ² / Par. set
REC.VFREE1	Specify recording address for REC.VAR1	-	Unsign.Long		- / -
REC.VFREE1	Specify recording address for REC.VAR2	-	Unsign.Long		- / -

Methods:

Command	Description	Parameter	Units	Range
GETD	Gets data from recording buffer in decimal form.	-	-	-
GETX	Gets data from recording buffer in hex form, data buffer is cleared afterwards	-	-	-
REC	Starts("on") / stops ("off") recording process	start / stop	-	"on", "off"

Memory related methods (Queries / modifications):

RAM related:

Command	Description	Parameter	Range
BDUMP	Gets hexadecimal memory dump in bytes	Memory address	Unsign.Int.
BMEMH	Query / Update memory byte in hex	Memory address	Unsign.Int.
BMEMD	Query / Update memory byte in dec	Memory address	Unsign.Int.
WDUMP	Get hexadecimal memory dump in words	Memory address	Unsign.Int.
WMEMH	Query / update hexadecimal word memory location	Memory address	Unsign.Int.
WMEMD	Query / update decimal word memory	Memory address	Unsign.Int.

EEPROM related:

Command	Description	Parameter	Range
CLEAR	Clear EEPROM content and drive life time variable by filling it with 0xFFFF (except code for Level I/II; Baldor/HD)		
EEDUMP	Display all EEPROM data (256 words).		
UP	Uploads EEPROM data to terminal (ASCII file)		

Operation Mode Control

Normal Modes Parameters:

Command	Description	Units	Range	Default	E ² / Par. set
SYS.MOD	Queries / updates system operating mode	-	0 : 3	1	E / P
MODE	Where 0 - current, 1 - velocity, 2 - position				

Normal Modes Variables:

Command	Description	Units	Range	Default	E ² / Par. set
STATUS	Queries drive status: DIS_HW, DIS_SW, ENABLE, BURN_IN, FAULT	-			- / -

Normal Modes Methods:

Command	Description	Parameter	Units	Range
DIS	Disables drive passively			
DISA	Disables drive actively, brake to stop, then disable control			
ENA	Enables drive			
HOLD	Stops drive and maintains position after stop			
QUIT	Stops drive and maintains position after stop			
STOP	Stops drive and maintains position after stop (CONT will resume the interrupted move)			
CONT	Continues interrupted move (interrupted by STOP)			

Note: In velocity and current mode, braking is with acceleration=zero.
In positioning mode (SYS.MOD 3), braking is with acceleration=MOT.ACC.

Sys.mod 0:**Current mode Parameters:**

Command	Description	Units	Range	Default	E ² / Par. set
CUR.BEMF	Back EMF voltage compensation, in percentage of nominal motor value Ke.	%	80 : 120	100	E / P
CUR.IPEAK	Queries / updates application peak current in percentage of DRV.IPEAK	%	0 : 1000	100	E / P
CUR.INOM	Queries / updates application nominal current in percentage of DRV.IPEAK	%	0 : 500	50	E / P
CUR.TOFR	Queries / updates mantissa of Torque Optimizer: Phase Advance or BEMF Compensation		0x0f00 : 0x1100		E / P
CUR.TOSH	Queries / updates Torque Optimizer Shift coefficient		16		E / P
CUR.SCAL	Corresponding current value to analog input voltage CUR.VOLT for setting of analog input scaling	0.1 % of CUR.IP	100 : 10000	1000	E / P
CUR.VOLT	Corresponding analog input voltage to current value CUR.SCAL for setting of analog input scaling	0.1 V/EAK	1 : 100	100	E / P

Current mode Variables:

Command	Description	Units	Range	Default	E ² / Par. set
CUR.CUR	Query for actual current command		0 : 65535		E / -
CUR					

Current mode Methods:

Command	Description	Parameter	Units	Range
CALC	Calculate current control parameters from MTR.*, DRV.* and CUR.* parameters.	torque equivalent	mV	-10000 : 10000
T	Commanding digital current command (torque equivalent)			
TS	Stops current commanded motion (started by T*command")			

Sys.mod 1 & Sys.mod 3

Velocity mode Parameters:

Command	Description	Units	Range	Default	E ² / Par. set
VEL.ACC	Queries /updates velocity acceleration limits (time to max. velocity).	RPM/ms	0 : 7500		E / P
VEL.ADZON	Queries / updates min. velocity in RPM	RPM	0 : Max_RPM		E / P
VEL.BW	Queries / updates velocity control band width	Hz	10 : 200		E / P
VEL.CTRL	Queries / updates velocity control type		0, 2		E / P
VEL.GV	Queries / updates velocity control proportional gain		0 : 32767		E / P
VEL.GVI	Queries / updates velocity control integral gain		0 : 32767		E / P
VEL.INRT	Load inertial, set in % of motor inertia MTR.JM	%	0 : 10000		E / P
VEL.LPFA	Bandwidth of single velocity control filter.	Hz	20 : 800	500	E / P
VEL.LPFB	Second Bandwidth of double velocity control filter (First s. VEL.LPFA).	Hz	20 : 800	500	E / P
VEL.LPFMOD	Type of velocity control filter (0: no filter, 1: filter with bandwidth VEL.LPFA, 2: double filter with bandwidths VEL.LPFA and VEL.LPFB	-	0 : 20	0	E / P
VEL.TRKFCT	Queries / updates velocity control tracking factor		-32768 : 32767		E / P
VEL.MXRPM	Queries / updates velocity control MAX RPM value. The limit for this value is internally calculated by the Application Bus Voltage and the Motor Voltage Constant. Absolute limit for velocity is 7500 RPM.	RPM	1000 : (7500)		E / P
VEL.SCAL	Corresponding velocity value to analog input voltage VEL.VOLT for setting of analog input scaling.	RPM	100 : 32767		E / P
VEL.VOLT	Corresponding analog input voltage to velocity value VEL.SCAL for setting of analog input scaling	0.1 V	1 : 100		E / P

Velocity mode Variables:

Command	Description	Units	Range	Default	E ² / Par. set
VEL.VREF	Queries velocity reference, commanded at analog input	RPM			- / -
VREF					- / -

Velocity mode Methods:

Command	Description	Parameter	Units	Range
VCRST	Velocity controller parameters reset to default values: Pole Placement controller: BW = 20 Hz, TRFCT = 0 , INRT = 0; PI controller: GV, GVI equivalent to Bandwidth 20 Hz			

Jog

Parameters:

Command	Description	Units	Range	Default	E ² / Par. set
JOG.TIME	Jog time in milliseconds	ms	3432448		E / -
JOG.TYPE	0 - continuous, 1 - step, 2 - square wave	-	0 : 2		E / -
JOG.VEL	Jog velocity in RPM, limited to maximum velocity VEL.MXRPM.		VEL.MXRPM		E / -

Methods:

Command	Description	Parameter	Units	Range
JOG	Commanding a Jog according to JOG.* parameters, with	Direction	-	"+" ; "-"
JS	Stops jog and returns to previous operation mode	-	-	-

Position Controller

Position Controller Parameters:

Command	Description	Units	Range	Default	E ² / Par. set
POS.FFA	Queries/updates acceleration FF factor unsigned integer ranged 0..100	-	25 : 100		E / P
POS.FFTYPE	Queries / updates FF type with position controller redesign 0 - FF none, 1 - velocity FF, 2 - acceleration FF	-	0 : 2		E / P
POS.FFV	Queries / updates velocity FF factor unsigned integer ranged within 0..100	-	25 : 100		E / P
POS.KP	Queries / updates position gain unsigned integer ranged within 25.. 200	-	25 : 100		E / P
POS.FEWRN	Queries / updates FE warning limits resolver: 1/4096 of revolution, encoder: 1/(4*SYS. encres) of revolution integer, > 0 (< 0: disabled)	1/4096 (resolver) 1/(4*SYS. encres) encoder	-32768 : 32767		E / P
POS.FEFAT	Queries / updates FE fatal limits 1/4096 of revolution, integer,	1/4096 of revolution	-32768 : 32767		E / P
POS.IPOS	Queries / updates FE in position limits 1/4096 of revolution, integer, > 0 (< 0: disabled)	1/4096 of revolution	-32768 : 32767		E / P

Variables:

Command	Description	Units	Range	Default	E ² / Par. set
POS.MPFE	Queries maximum position following error	1/4096 of rev.			- / -
MPFE					- / -
POS.PFE	Queries position following error	1/4096 of rev.			- / -
PFE					- / -
PREF	Queries for position reference	1/4096 of rev.			- / -
POS.REF	Queries position controller reference, 1/4096 of revolution	1/4096 of rev.			- / -
POS.FEST	Returns follow error status: 0 - normal, 1 - in position, 2 -warning, 3 - error	-	0 : 3		- / -
FEST					- / -

Methods:

Command	Description	Parameter	Units	Range
PRST	Resets position following error	-	-	-

Sys.mod 2: Pulse Follower (Handwheel respectively Pulse/Direction)**Parameters:**

Command	Description	Units	Range	Default	E ² / Par. set
HW.GRFX	Queries/updates mantissa HW gear parameter, negative value means negative gear.		-32767 : 32767		E / P
HW.GRSH	Queries/updates shift HW gear parameter		0 : 32767		E / P
HW.PLC	GEAR Queries/ updates PLC gear ratio		0 : 65535		E / P
HW.RES	Queries / updates HW resolution in pulses per revolution (only necessary for	pulses/rev.	-32768 : 32767		E / P
HW.TYPE	Queries / updates HW type: 0 - None, 1 - Pulse and Direction at connector X3, 2 - A leads B at connector X9, 3 - B leads A respectively, Pulse and Direction at connector X92, 4 - A leads B at connector X32				E / P

BALDOR[®] **MOTORS AND DRIVES**

BALDOR ELECTRIC COMPANY
P.O. Box 2400
Ft. Smith, AR 72902-2400
(479) 646-4711
Fax (479) 648-5792
www.baldor.com

CH TEL: +41 52 647 4700 FAX: +41 52 659 2394	D TEL: +49 89 90 50 80 FAX: +49 89 90 50 8491	UK TEL: +44 1454 850000 FAX: +44 1454 850001	F TEL: +33 145 10 7902 FAX: +33 145 09 0864
I TEL: +39 11 562 4440 FAX: +39 11 562 5660	AU TEL: +61 29674 5455 FAX: +61 29674 2495	CC TEL: +65 744 2572 FAX: +65 747 1708	MX TEL: +52 47 61 2030 FAX: +52 47 61 2010