

NP-20 z

OPERATING INSTRUCTIONS

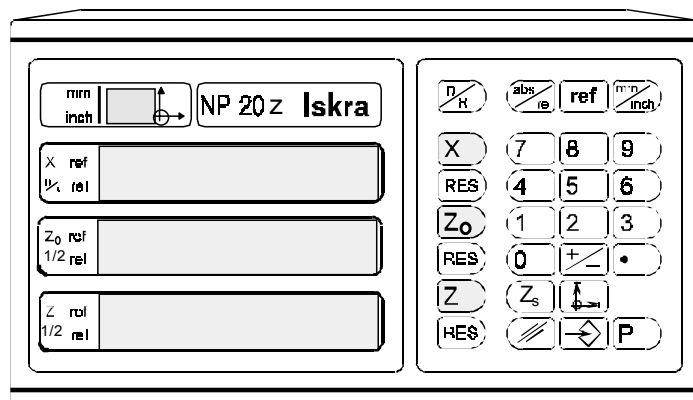

**© Copyrights 2002
Iskra TELA d.o.o.
Printed in Slovenia 2002**

CONTENTS

1. SCOPE OF DELIVERY	5
2. GENERAL DESCRIPTION	5
3. INSTALLATION AND CONNECTION OF THE DEVICE	6
3.1. External dimensions and fastening	6
3.2. Connection	6
3.3. Connectors	7
4. ADJUSTMENT TO THE MACHINE	10
4.1. Entry of machine parameters	10
4.2. Entry of technological parameters	14
5. MEASURING FUNCTIONS	15
5.1 Reference mode	16
5.1.1. Calibration of absolute position with reference mark	16
5.1.2. Determination of reference value with reference pulse	16
5.1.3. Manual entry of reference values in the p90 parameter	17
5.2.Absolute mode	18
5.2.1. Preset of absolute position	19
5.2.2. Reset of absolute positions	20
5.2.3. Mm/inch switching-over	20
5.2.4. Radius/diameter switching-over	20
5.2.5. Halve of measured value in z axis	21
5.2.6 Freeze of absolute position	21
5.2.7 Datum points (dp00...dp99)	22
5.2.7.1 Datum point selection	22
5.2.7.2 Setting the datum points by position enter	23
5.2.7.3 Datum points setting by manual parameter entry	23
5.3.Relative mode	24
5.4.Distance to go mode	27
5.5. Axis shift velocity measuring mode	27
6. SERIAL DATA TRANSFER	28
7. STATUS AND ERROR INDICATION	30
8. TECHNICAL DATA	32

1. SCOPE OF DELIVERY

Position readout **NP-20z** for lathes.

Possible options: R, K, B.

Spare fuse (link) 0.3 A T for 220 V~, i.e. 0.6 A T for 110 V~.

Power cable with safety plug for 220 V, 50 Hz and three-pole socket, length 3 m.

NOTE: Meanings of options designations:

R connector RIE (only for rotary transducers)

K interface RS 232 C for serial communication

B battery backup

2. GENERAL DESCRIPTION

Position can be measured both in transverse and longitudinal axes (X, Z) and in an additional axis (Z_0) that is parallel to longitudinal. Position value in the auxiliary axis can be continuously added and is indicated in the position of the related main axis (Z), or can be display separately on the display Z_0 . X, Z_0 and Z displays indicate the **absolute** or the **relative** position. When the relative mode is selected in one or in both axes, the related indicator REL is lit. In the relative mode it is possible to measure depending on the relative zero, which can be selected by pressing the key REL in the current position. **Incremental linear or rotary measuring transducers** with square or sine wave measuring signals are used for position measuring.

Built-in "**monitoring functions**" assure reliable operation, assistance at work and easy troubleshooting of eventual errors in the measuring system or during the operation. If an error occurs a message appears on the appropriate display, indicating the cause for the error, e.g.: pressure on a wrong key (<Err type>), exceeded max. Movement speed (<Err 1>), undetermined parameter (<Err PAr>) etc. The messages are deleted and reception acknowledged by the key DELETE.

Position readout NP-20 is optionally equipped with battery backup system. This system assures, in the case of power failure, storage of absolute position in the moment of power failure. When the power is set readout shows the last absolute position before power failure.

3. INSTALLATION AND CONNECTION OF THE DEVICE

3.1. EXTERNAL DIMENSIONS AND FASTENING

S – compact table version

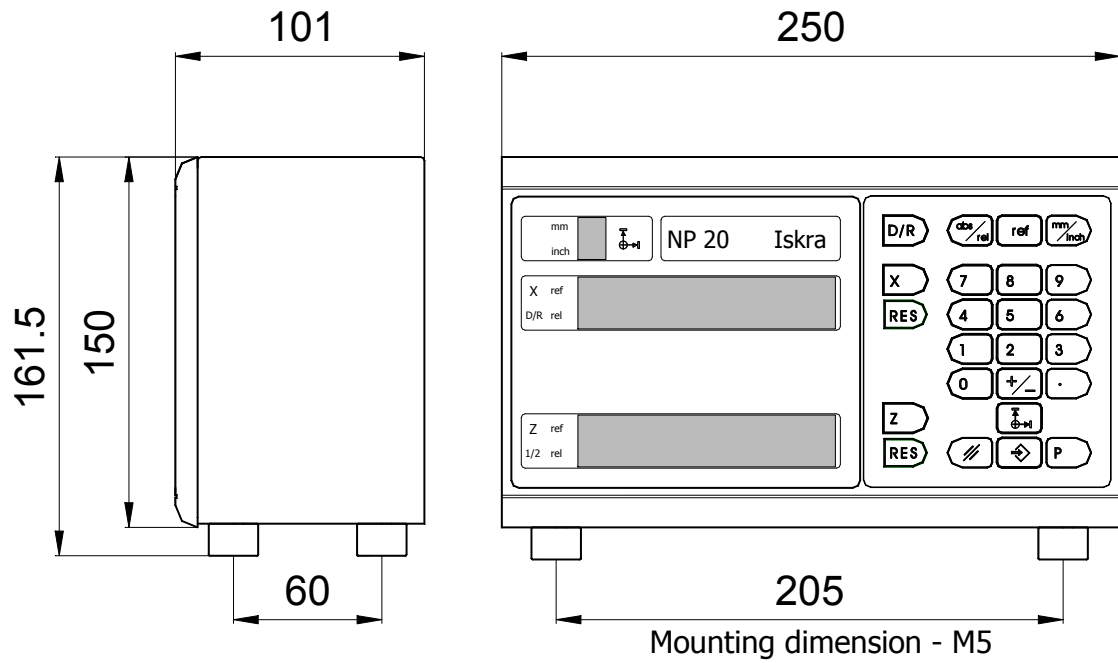

P – Panel (Build in) version

Panel mounting dimension: $244+0.5 \times 145+0.5$

Sheet thickness: 1.6 mm max.

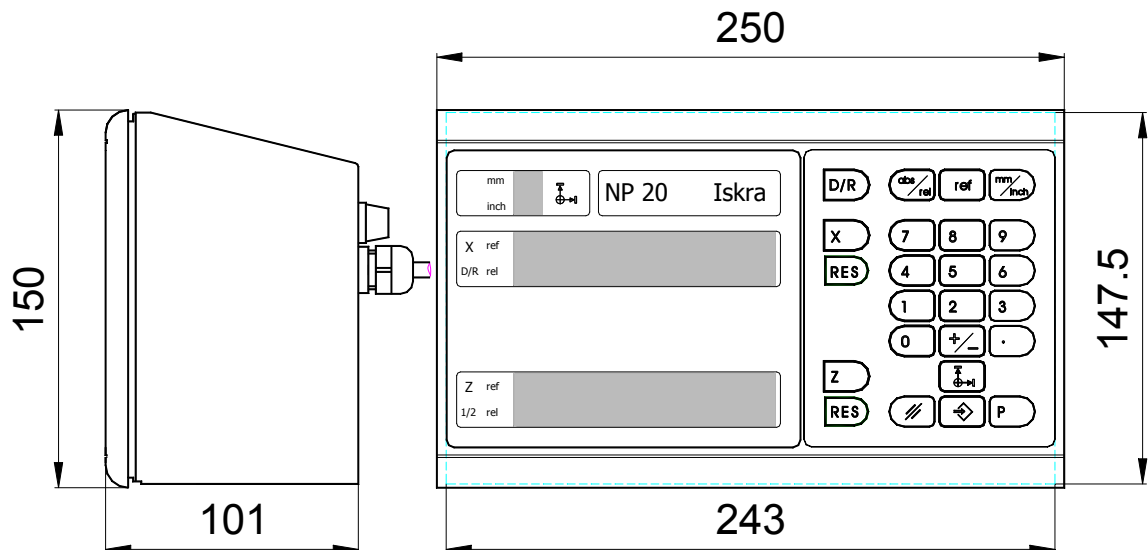

T – Tabletop version

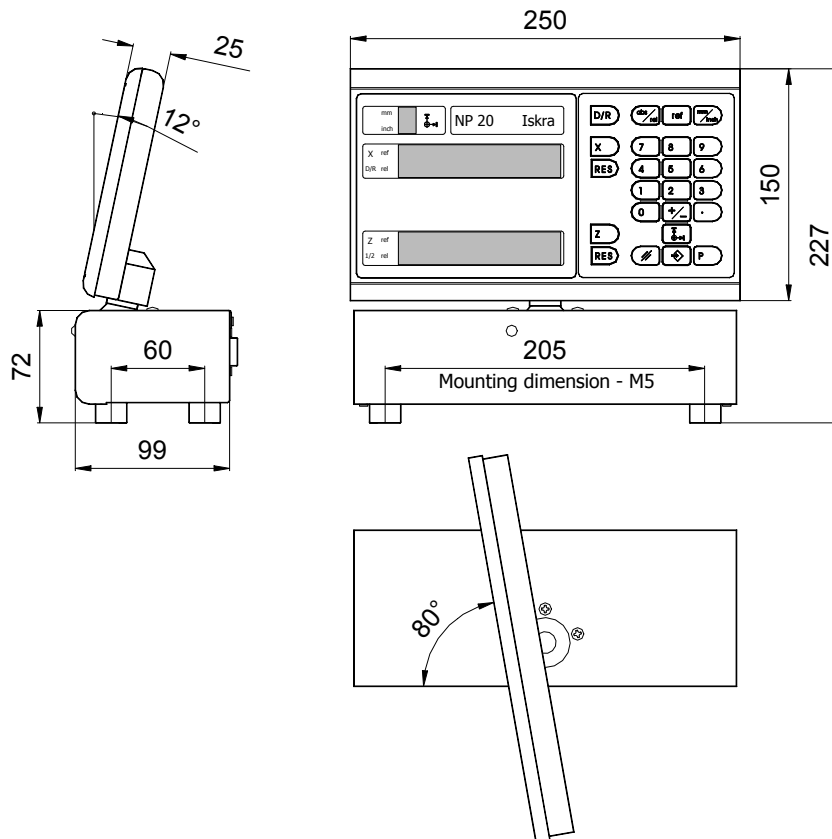

c – Console version

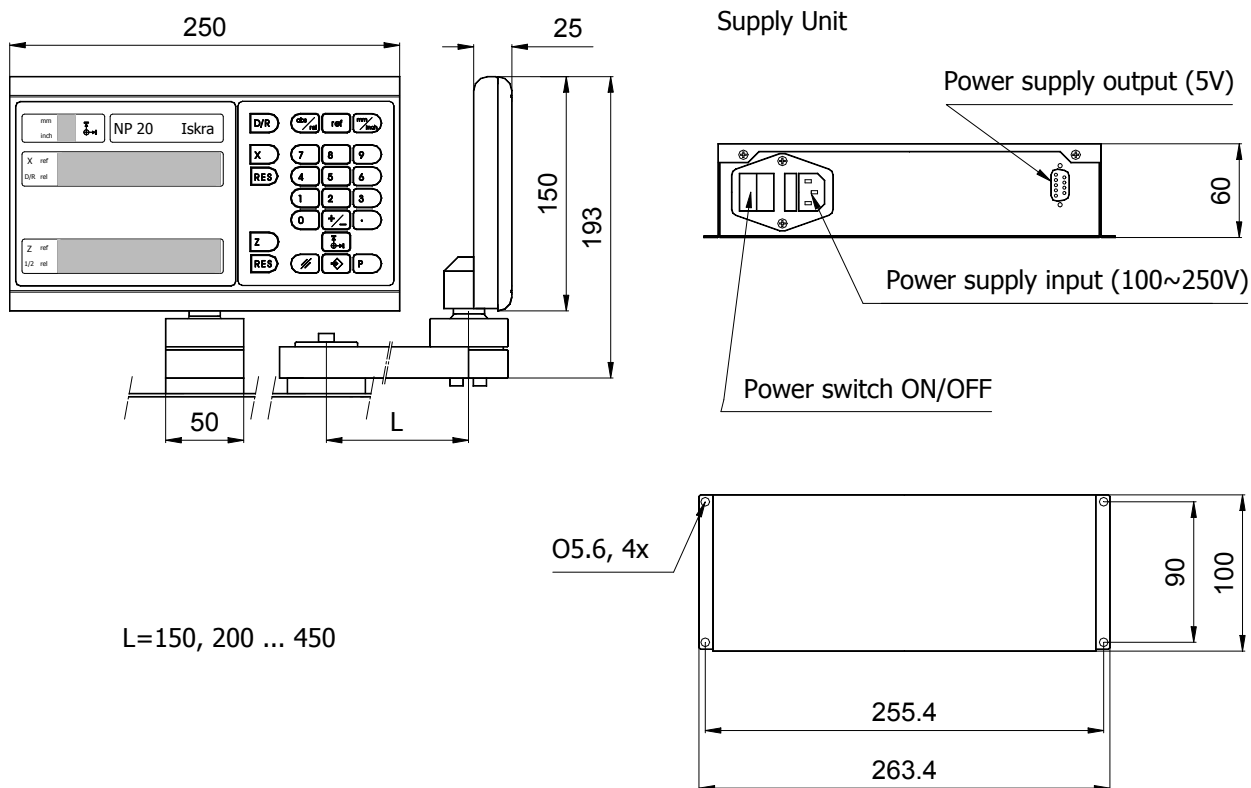

L=150, 200 ... 450

Clearance of at least 120 mm has to be provided for accommodating the electrical connections at rear of the device.

3.2. CONNECTION

Correct connection of the device and of the measuring system are very important for reliable operation, especially when the device is applied in strenuous working conditions (close to power cables, inductive load switches etc.). The following basic rules should therefore be observed during the connection of the device:

- The housing of the device must always be grounded in the same grounding point as the machine, either via the grounding conductor of the mains power supply cable with safety plug or by connecting a special grounding conductor to the grounding screw at rear of the device. The cross-section of the grounding conductor shall not be less than 1.5 mm², and by the shortest route should be connected to main grounding point of a machine.

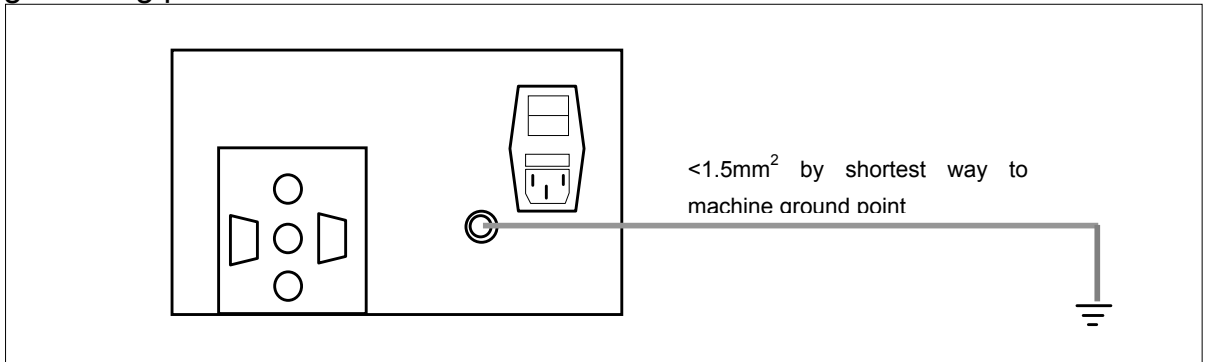

- Cables with measuring and control signals of the device (connectors X, Z, Z', RIE, RS232) have to be laid as far as possible from the power cables on the machine and from the other powerful sources of electromagnetic disturbances (relays, contactors, motors, transformers, switch-mode power supply).

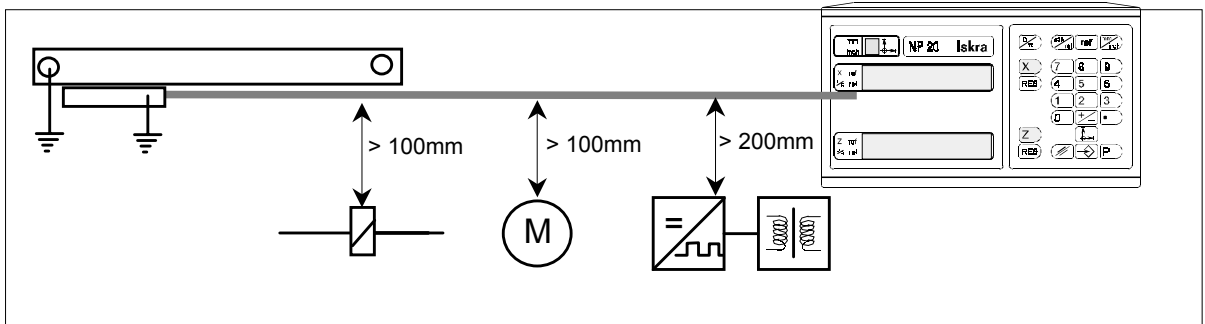

- Inductive sources of disturbance on the machine or in the environment of the device (couplings, relays, magnetic valves etc.) have to be choked by parallel-connecting corresponding standard choking elements (diodes, zener diodes, RC elements for the DC power supplied elements and RC elements for the AC power supplied elements).

Recommended value for protection elements			
V	R	C	D
< 60 dc			1N4004
125 V dc	220E/5W	2 uF /600V	
250 V dc	220E/5W	0.5uF 1000V	
115 V ac	220E/1W	0.5 uF /600V	
230 V ac	220E/5W	0.5 uF /1000V	
440 V ac	220E/5W	0.5 uF /2000V	

3.3. CONNECTORS

Axes Connectors for square-wave Encoders:

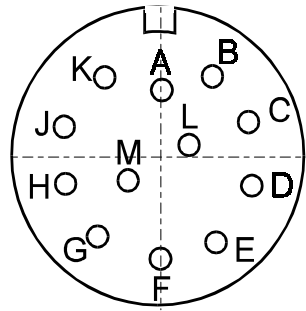

Viewing the rear plate

Connector contacts:

- A Shield (grounding)
- B GND (0 V)
- C Signal A
- D Signal A₋
- E Signal B
- F Not connected
- G Signal RI
- H Signal RI₋
- J Not connected
- K +5 V
- L Signal B₋
- M Not connected

Connector for RIE switches (option R):

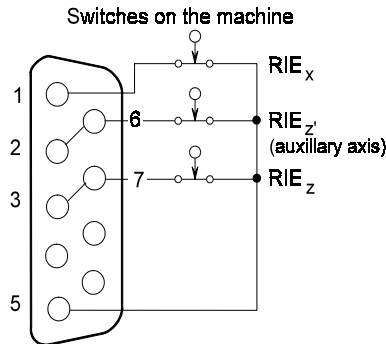

Viewing the rear plate

Connector contacts:

- 1 RIE_x
- 2 RIE_z'
- 3 RIE_z
- 4 Not connected
- 5 5 V
- 6 Input RIE_z' (auxiliary axis)
- 7 Input R_{yes}
- 8 Not connected
- 9 Not connected

NOTE: The RIE switches are only required when rotary measuring transducers are used. The installation of the switch has to assure that it is only active for the particular reference pulse at which we want to set the reference value (the transducer generates one reference pulse at each rotation). The break contact of the switch is used.

Connector for serial interface RS 232 (option K):

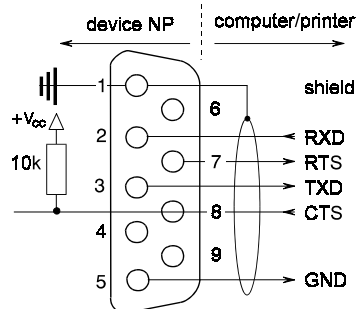

Viewing the rear plate

Connector contacts:

- 1 Shield (grounding)
- 2 RXD input (data reception)
- 3 TXD output (data transmission)
- 4 Not connected
- 5 GND (0 V)
- 6 Not connected
- 7 RTS output (Request to send)
- 8 CTS input (Clear to send)
- 9 Not connected

4. ADJUSTMENT TO THE MACHINE

4.1. ENTRY OF MACHINE PARAMETERS











The device is adjusted to the machine by entering the appropriate machine parameters. These values are stored in the permanent, non-volatile memory, until the new values are entered.

Numbers from P1 to P49 are assigned to machine parameters and higher numbers to technological parameters.

Machine parameters can only be set by entering first the value 3.14 (P0 = 3.14) for the P0 parameter. This is the protection code that protects the parameters against unintentional entry or deletion. This code entrance is active until the device is switched off.

Use the delete code P0 = 6.28 for deleting all parameters. This is recommendable especially when the installed EPROM circuit is replaced by a new one, i.e. by another software version.

The following diagram shows the procedure for calling, monitoring and entering the parameters in different modes of selection, by entering the machine parameter P0=3.14:

PROCEDURE:	DISPLAY X:	NOTES:
  		Parameter selection
	P00 codE codE _ _ _ _	Alternate designation/value display. Dashes for "empty" parameter.
   	3.14.	Value selection, right point is flashing
	P00 codE 3.14	Value entry, alternate indication of designation and parameter value.
	P01 Incr	Switchover to next parameter.
		Abandon of parameter settings or reviewing

Having entered the protection code, continue entering the remaining machine parameters. When you have set any parameter by pressing the key ENTER, the next parameter appears on the display.

In case you do not want to set or change it, press the key ENTER in order to choose the following parameter. For direct selection of a particular parameter, press the key P and enter the parameter number (e.g. P 090). In case of a typing error, press the key DELETE and start again the entry.

<P01 Incr> The counting direction, the measuring mode, the number of decimal places, and the weight factor by which a measuring increment affects the last digit in the X or Z displays.

The weight factor is a fraction with any two or three-digit whole number in the numerator and the denominator (altogether 5 digits). Also the "00" or "000" numbers, meaning 100 or 1000, respectively, are admissible.

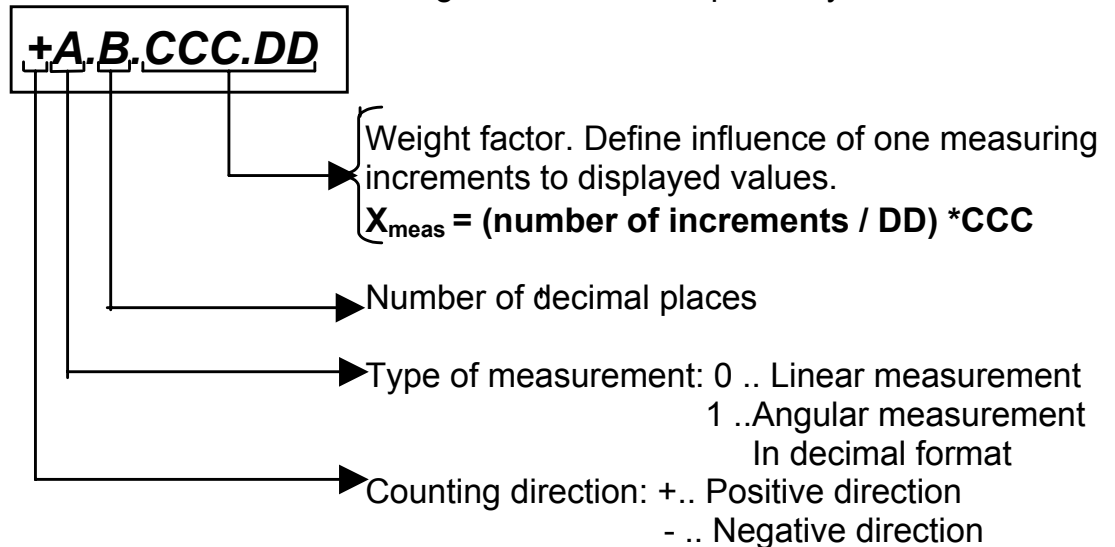

- Weight factor (**CCC.DD**):
Define the influence of measuring increments to displayed values:

$$X_{meas} = (\text{number of increments} / DD) * CCC$$

Number of incrementscounted number of increments
From linear or rotary encoder
 X_{meas} measured value
 (Number of increments/DD).... integer representation of
divide value without a rest

- Number of decimal points (**B**)
Define the number of digits on the right side of decimal point. Can be any number between 0 and 4.
- Type of measurement (**A**)
Define the type of measurement
 0 Linear measurement
 1 Angular measurement in decimal
Format.
- Counting direction
Define the direction of counting, when a positive transition of A signal precede a positive transition of B signal.
Empty..... Positive direction
 - Negative direction

Examples:

Scale resolution	P01	Display resolution
------------------	-----	--------------------

0.5 μm	0.4.005.01	0.0005
	0.3.001.02	0.001
	0.3.005.10	0.005
1 μm	0.3.001.01	0.001
	0.3.005.05	0.005
	0.2.001.10	0.01
5 μm	0.3.005.01	0.005
	0.3.010.02	0.010
	0.2.001.02	0.01

<P03 Lin.c.> The linear correction factor. Values from -65535 to +65535 are admissible. The entered value represents the coefficient in particles per million particles with which the device corrects the measured value before indicating it.

$$X_{\text{disp}} = X_{\text{meas}} * (1 + P03 * 10^{-6})$$

X_{disp} displayed value (compensated)

X_{meas} measured value

P03 Value of parameter 3

The zero of the correction line is set by the device in the last written position (PRESET, RESET, absolute position entry by means of RI, relative position entry by means of key REL).

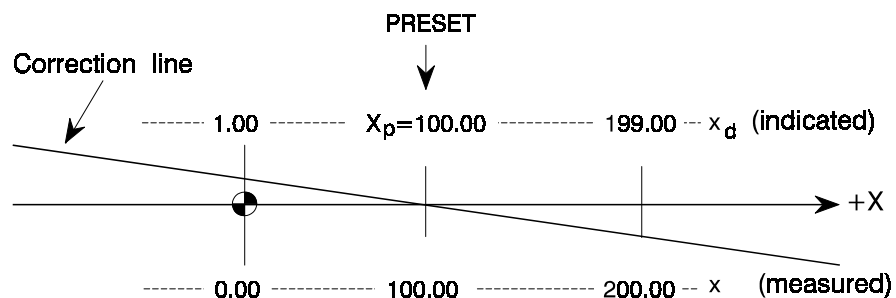

EXAMPLE: The last written position is $X_p = 100.00$ mm, $P07 = -10000$ (this corresponds to -10000 particles per million particles, i.e. -1%).

$$x_d = x + (x - X_p) \cdot P03 \cdot 10^{-6}$$

For $x = 0$: $x_d = 0 + (0 - 100) \cdot (-10000 \cdot 10^{-6}) = +1.00$

For $X = 200$: $x_d = 200 + (200 - 100) \cdot (-10000 \cdot 10^{-6}) = +199.00$

Usage of linear compensation is recommended:

- for older machine with bended guide ways with purpose of eliminating Abbe error;
- for usage of angular measurement on the rotary table by means of rotary encoder, with purpose to adjust required displayed resolution with encoder's line number, and gear ratio of rotary table mechanism;

In a case if angular measurement on the appropriate axis is selected, and linear compensation is different then 0, displayed value can be in the range of $\pm(360^\circ + 15^\circ)$, Reason for that limitation is to avoid arithmetical error caused by limited number lengths.

<P05 doff> When the digits change too quickly, the last display digits are shaded:

P05 = 0: Shading off.

P05 = 1: Shading on.

<P06 toll> Counting error tolerance.

P06 = 0: Counting error monitoring is off.

P06 = 1..15: Counting error value in measuring increments that causes device error indication <Err 2>.

NOTE: Counting error monitoring (patented by ISKRA) is active in the manual mode even when the measuring system is not calibrated by means of the reference value. Every time the reference point on the measuring transducer is passed over, the device measures the reference value and compares it with the reference value recorded at the previous passage over the reference point. In case the values are not equal and the difference between them exceeds the tolerance (P06), the device indicates the error <Err 2>. When this message is deleted, the device also indicates the value of this difference.

<P07 232c> Define the baud rate for serial communication interface (option K).
Possible values are: 300, 600, 1200, 2400, 4800, 9600,

<P08 n.LF> Define the number of empty lines, which are outputs after print out a one message. Possible values are 1 to 50.

<P11 Hold> Define the function of key RES:

P11 = 0 Key "RES" will reset absolute position of appropriate axis

P11 = 1 Key "RES" will freeze (hold) current absolute position of appropriate axis.

<P15 dCr> Define type of reference mark used on the measuring encoders for main axes

P15 = 0: Standard reference mark.

P15 = 1: DCR reference marks

4.2. ENTRY OF TECHNOLOGICAL PARAMETERS

Technological parameters are entered into permanent memory in the same way as the machine parameters except that it is not necessary to enter first the protection code P0 = 3.14.

<P90 rEF> Reference value for X or Z axis. In the auxiliary axis the 0 value is assumed automatically.
Reference value represent a distance in position (or angular) units from of absolute zero point and reference point on the linear (or rotary) encoder.

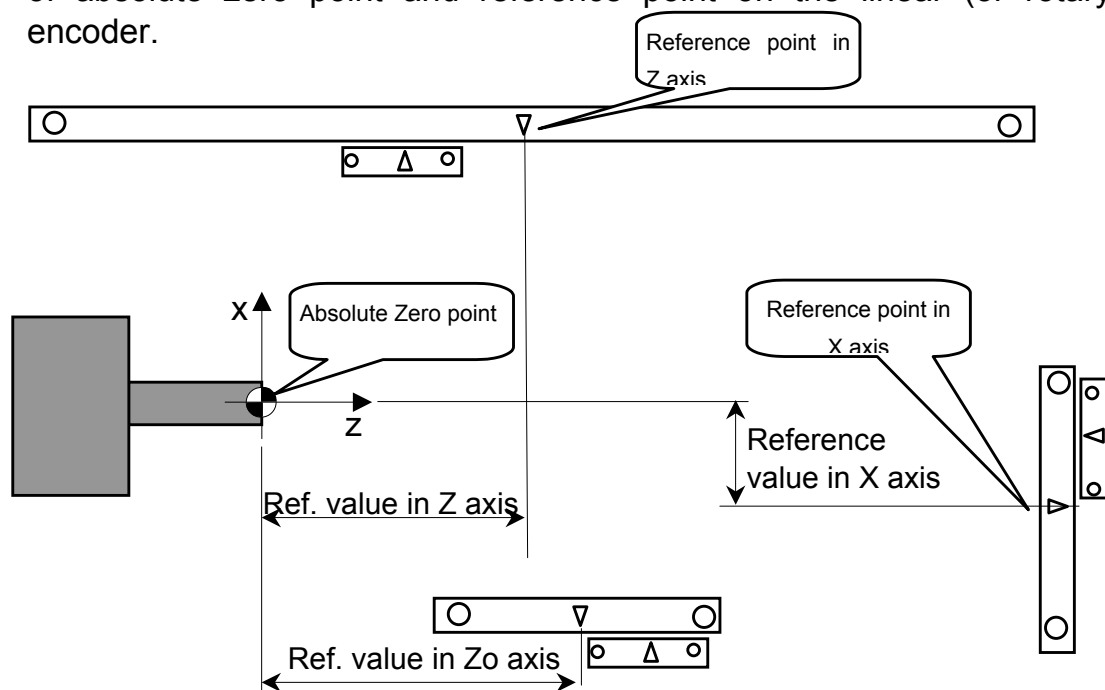

In the case, if Distance coded reference is used Reference value represent a distance in position (or angular) units from zero point of absolute zero and 1st reference point on the linear (or rotary) encoder.

<P101 dP01> Coordinates of the datum point DP1 in the X, Z₀ and Z-axis.

<P199 Dp99> Coordinates of the datum point DP99 in the X, Z₀ and Z-axis.

5. MEASURING FUNCTION

NP 20 can be set in different modes of operation, performing the proper measuring functions or settings. The conditions which cause transitions between different modes is shown in diagram below:

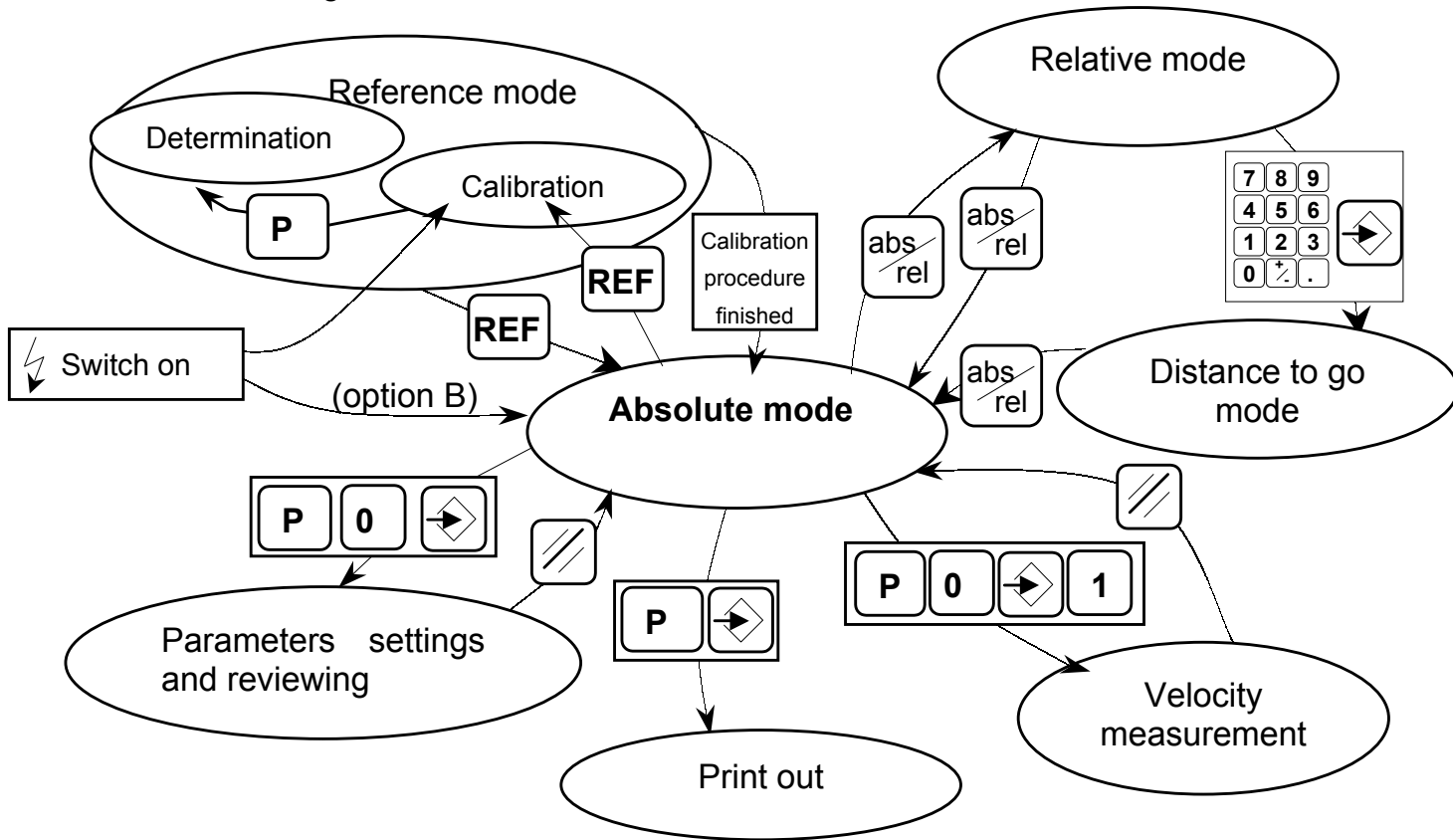

Selected mode in which NP 20 temporary operate is marked by indications on the display according to table below:

Indications			Mode	Calibration status
Ref	X or Z	Rel		
Off	Off	Off	Absolute	Calibrated
Off	On	Off	Absolute	Calibrated
Off	Off	On	Relative	Calibrated
Off	On	On	Relative	Calibrated
On	Off	Off	Absolute	Non-calibrated
On	On	Off	Absolute	Non-calibrated
On	Off	On	Relative	Non-calibrated
On	On	On	Relative	Non-calibrated
Pulse	On	Off	Reference – calibration	Non- calibrated main axis Calibrated auxiliary axis
Pulse	On	Pulse	Reference – calibration	Non- calibrated main axis Non-calibrated auxiliary axis
Pulse	Off	Off	Reference – calibration	Calibrated both axes
Pulse	Pulse	Off	Reference – determination	Determination of reference value

5.1 REFERENCE MODE

If the NP20 is equipped with battery back-up system (option B) , after switch on it is set to absolute mode, REF indications lights steady indicating that absolute position is not calibrated. If user like to calibrate absolute position, he should by pressing to key “REF” enter into the reference mode.

If the NP20 is not equipped with battery back-up system (without option B), the device after a switch on is automatically set to the reference mode. Axes indications lights steady, indicating that these axes have not been calibrated.

5.1.1 CALIBRATION OF ABSOLUTE POSITION WITH REFERENCE MARK



Calibration of absolute position requires, that device is set to the reference mode, and reference value should be entered into the parameter P90.

If reference value has not been entered into P90, when device is set to reference mode, message: “*ref* ___” will appear on the display of corresponding axis. In that case user should enter reference value by procedure describe in chapters 5.1.2 or 5.1.3.



PROCEDURE:	DISPLAY	NOTES:
		Entrance in the reference mode calibration; If reference value have not be entered “ <i>ref</i> ___” is displayed
Pass over the reference points on the encoders		After reference mark is passed display starts to display the position. In the case if auxiliary axis is used, first pass the reference in that axis, and than in main axis. When calibration procedure is finish NP 20 automatically return to absolute mode.

5.1.2. DETERMINATION OF REFERENCE VALUE WITH REFERENCE PULSE

It is used when we want to "save" an already selected absolute coordinate system so that we can re-establish it in case it gets lost when the device is switched off or for other reasons.

PROCEDURE:	DISPLAY	NOTES:
Set the NP20 to Absolute mode	Shows position	In this point NP 20 is set to the absolute mode
Drive the tool to known position	Shows position	It can be done by turning diameter, and then measure it (by calliper, or micrometer)
Preset the known position to axes	Presetting	Use the procedure describe in chapter 5.2.1
 	Shows position	Set the NP 20 to reference mode – determination
Pass the reference marks on both axis		In the case if auxiliary axis is used, first pass the reference marks in that axis, and after in main axis. NP 20 will inform the receiving of reference mark by sound. After passing of reference mark, NP20 will be set to absolute mode, and reference value will be entered into the P90

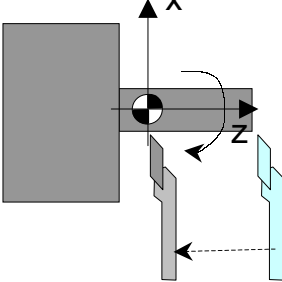
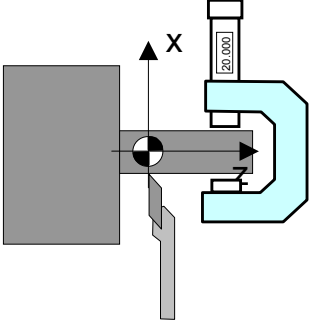
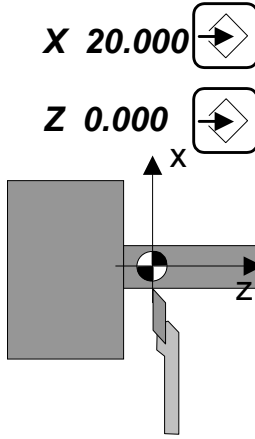
EXAMPLE:

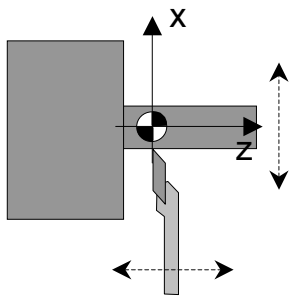
Turning	Measuring	Presetting	Determination
NP 20 is set to ABSOLUTE mode			NP 20 is set in REFERENCE mode
		 X 20.000  Z 0.000 	 REF P

5.1.3. MANUAL ENTRY OF REFERENCE VALUES IN THE P90 PARAMETER

This mode is generally used only for testing, e.g. when we want to enter the zero reference value in both axes:

NOTE: Do not enter the parameter for the auxiliary axis as it automatically assumes the zero value.

5.2. ABSOLUTE MODE

Absolute mode is basic operation mode of NP 20. In this mode NP 20 display the absolute position, which can be calibrated or non-calibrated in this mode it is possible to switch display of Zo axis to be displayed separately or added with axis Z.

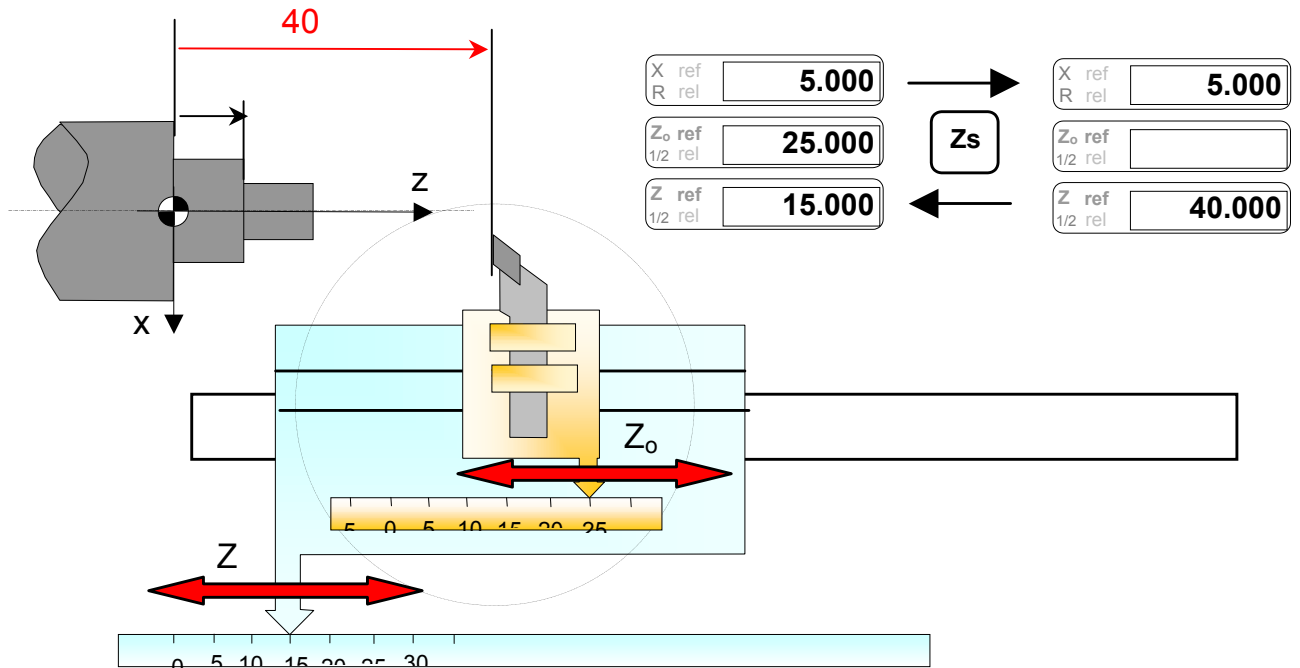

If NP 20 is set to any other mode of operation, it will be returned to absolute mode after specified task in the other mode is performed. In the absolute mode it is possible to preset the absolute position, reset the absolute position, switch over the metric or inch measuring units, switch over the radius or diameter position display in tool axis, halving the measured value in longitudinal axis, operate in a different datum points or preset datum points value.

Separate display of Zo axis is very useful, in the case when taper's shape should be machined.

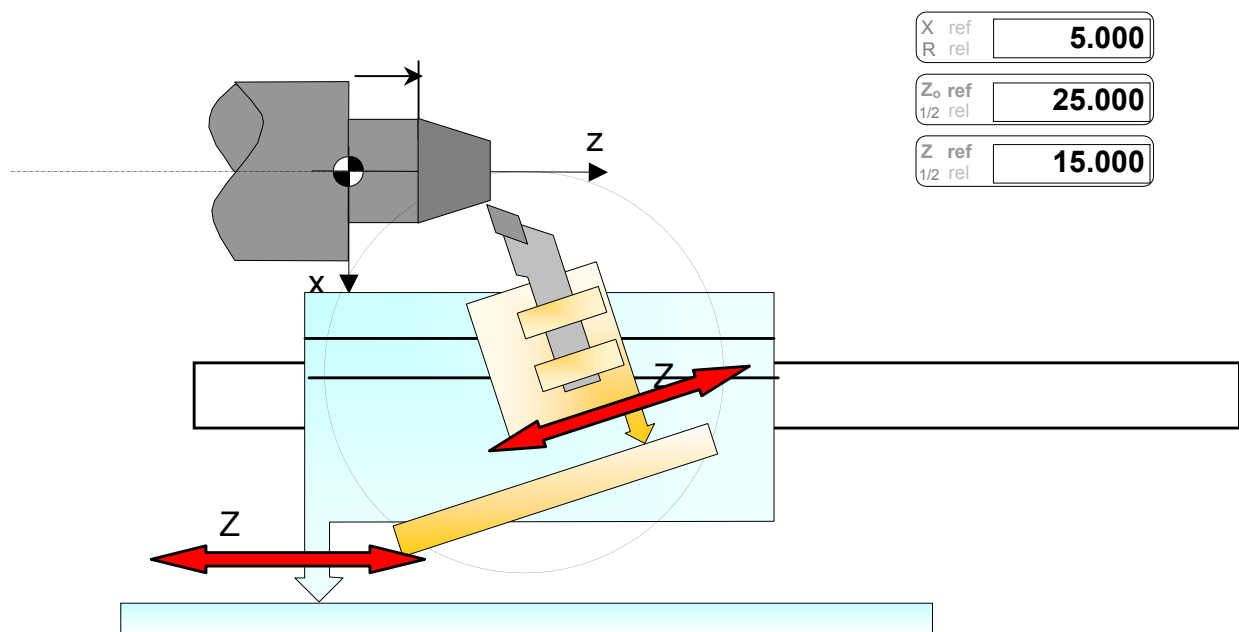

5.2.1. PRESET of ABSOLUTE POSITION

The absolute position of the measuring system can be selected optionally, by manually entering the axis position value. First select the axis (the axis indicators is lit) then the position value (the right decimal point on the axis display is flashing) and then confirm the entry by pressing the key ENTER (the right decimal point goes out). Preset of absolute position can be done in radius or in diameter.

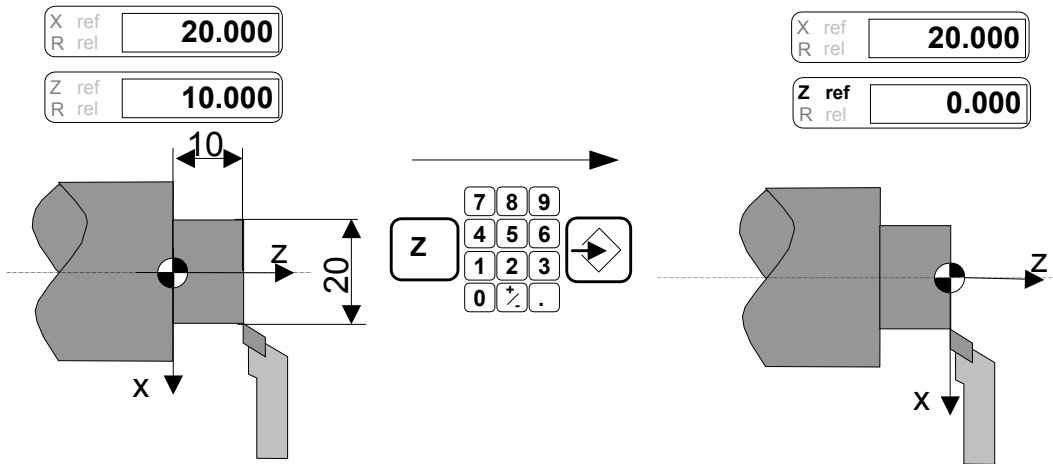

PROCEDURE	DISPLAY	NOTE
		Device is set to absolute mode, no axis is selected.
	Axis indicator light steady	Choose the axis in which you like to preset new absolute position
	Axis indicator light steady; Decimal point on last typed digit pulsate	On numerical keyboard type the required new absolute position
	New position is displayed	Confirmation of new absolute position. The old absolute position is loosed
	No number on the axis display	Deleting of typed numbers due to typing failure, or other reason.
	Old absolute position	Abandon of absolute position preset; Old absolute position is maintained.
		Device is set to Absolute mode

5.2.2. RESET of ABSOLUTE POSITIONS

If the parameter P11 is set to "0" (see chapter 4.1), the absolute position of the measuring axes can be directly reset by RESET key of corresponded axes.

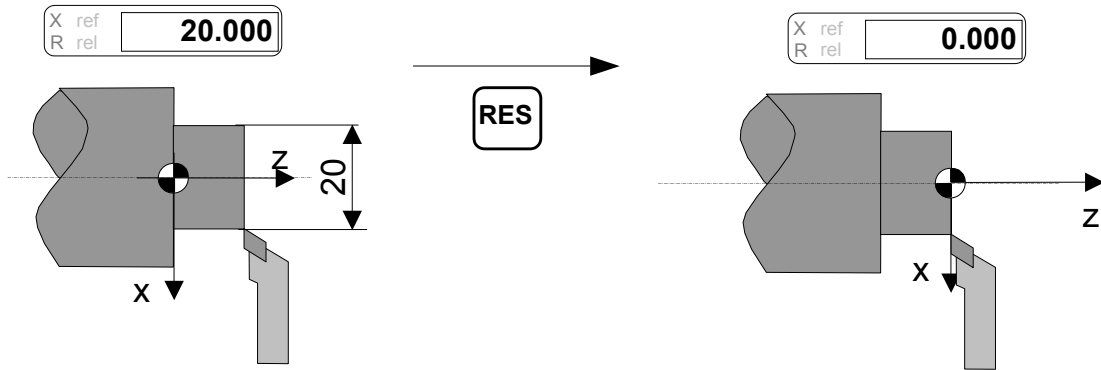

Reset of absolute position will cause:

- loss of old absolute position
- if axis was calibrated it will become non-calibrated

5.2.3. Mm/Inch SWITCHING-OVER

The units in which the position is displayed can be toggle between metric's and Inch's units, by pressure to key: mm/inch. Unit selection is valid for both axes.

Conversion rate is: **1 inch = 25.4 mm**

The status indicator shows selected units. After switch on of the NP20, position will be displayed in units, which was active before switch off.

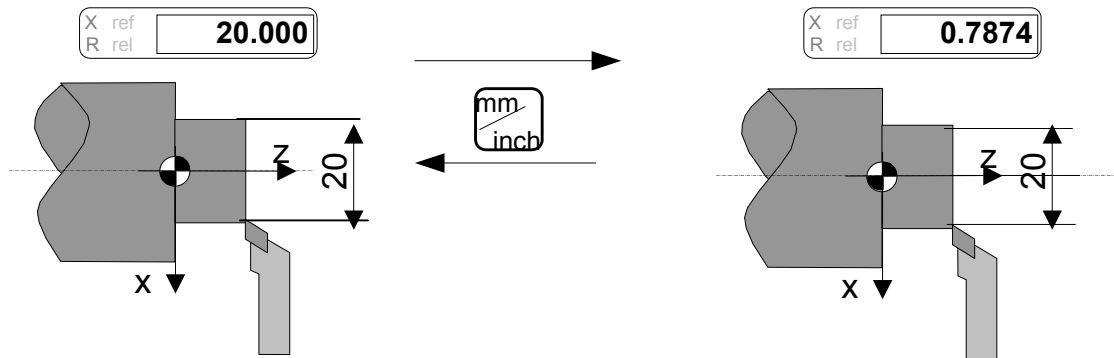

5.2.4. RADIUS/DIAMETER SWITCHING-OVER

Position of tool axis (X-axis) can be displayed in Radius or Diameter. After switch on NP 20 display position of tool axis (X) in diameter, by pressure to key R/D position display will be toggle to radius. Selected display mode is indicated on R/D status indicator.

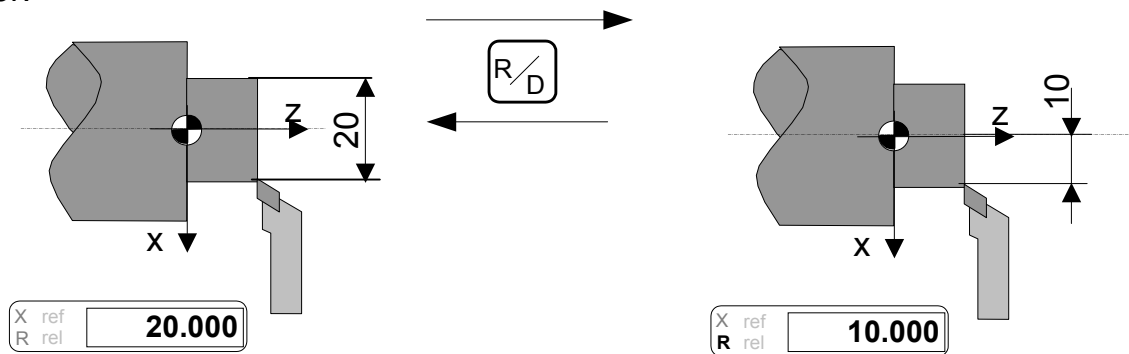

5.2.5. HALVE OF MEASURED VALUE IN Z AXIS

Halve of measured value in Z axis is purposed to simply find the middle point between two points along the Z-axis. Halve function is activated **only if Z-axis is selected** by key R/D.

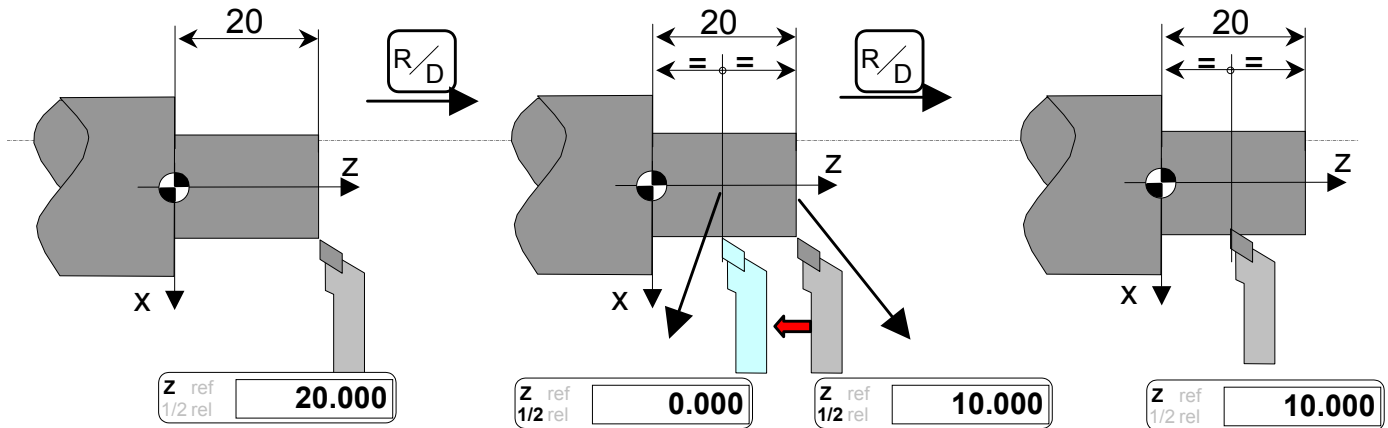

5.2.6. Freeze of absolute position

If the parameter P11 is set to "1" (see chapter 4.1), the pressure to key **RES** will cause freeze of current position on the display. Pulsating of proper axis designator on axis status display indicates freeze of proper axis. In the back position is followed, and following pressure to key "RES" will release position display.

5.2.7. DATUM POINTS (DP00...DP99)

Datum points are used for reversible shifting of the coordinate origin point of the measuring system in one or in both axes. When datum point is selected, position display will show the position described by following equation

$$X_{\text{dispDPx}} = X_{\text{disp0}} - P9x$$

- X_{dispDPx} position display in X datum point
- X_{disp0} position display in absolute system
- $P9x$ value of parameter P9x

Datum point's shift of coordinate origin can be used for:

- processing an identical work piece at several different working locations;

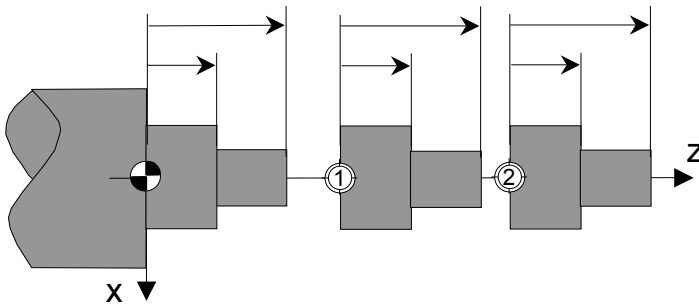

- Preselecting some points in the absolute coordinate system;

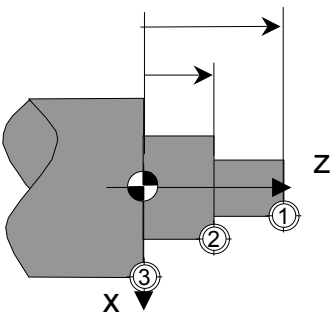

- presetting tool offsets

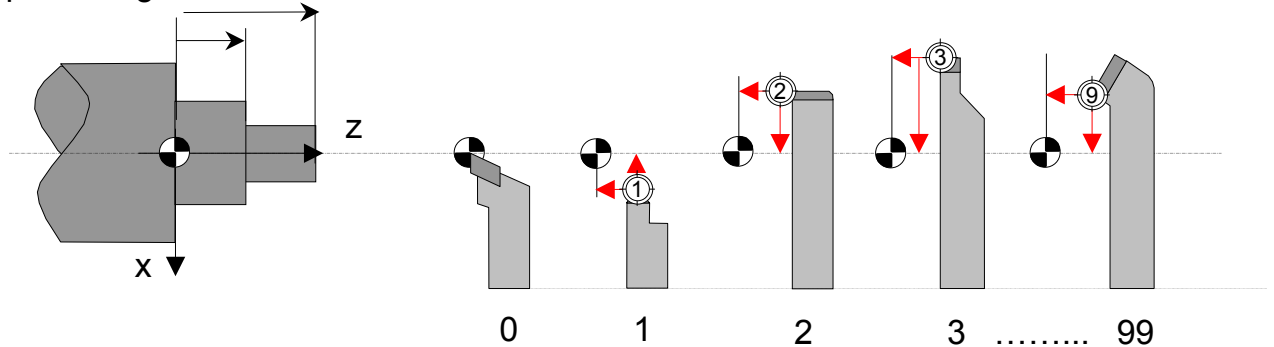

The position of datum points DP1...DP99 depending on the absolute starting point is determined by setting, for each axis separately, the P101...P199 parameter values. Datum point can be set by position preset, or by datum point offset value entry in corresponded parameter

The datum point DP00 has always the $X = 0$, $Z = 0$ value, meaning that it is situated in the starting point of the absolute measuring system.

When the absolute coordinate starting point is shifted to some other point, the datum points are also automatically shifted, by keeping the same relative position depending on the starting point as they had before.

5.2.7.1. DATUM POINT SELECTION

Pressing the key DP and the appropriate number select the datum point:

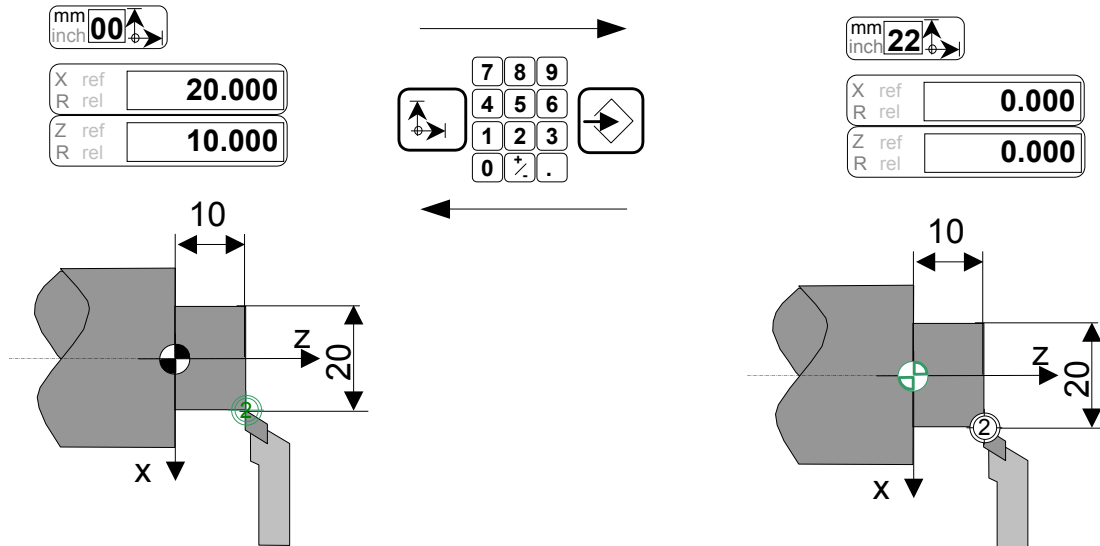

If corresponded parameter P9X of datum point DPX is not defined (empty), after selection of datum point is done position display(s) will show: "dPOX ___".

When datum point is selected, indication "ref" is switch off, and information about calibration status is hidden.

All settings (mm/inch, R/D...) will stays the same as in previous datum point, except axis selection, which through any transitions became deselected.

5.2.7.2. SETTING THE DATUM POINTS BY POSITION ENTRY

Datum point's offsets (values of parameters P1xx), can be set by position preset procedure if position preset is done when datum point is selected

The device automatically calculates the corresponding parameter values of the datum point and enters them into the memory, e.g.:

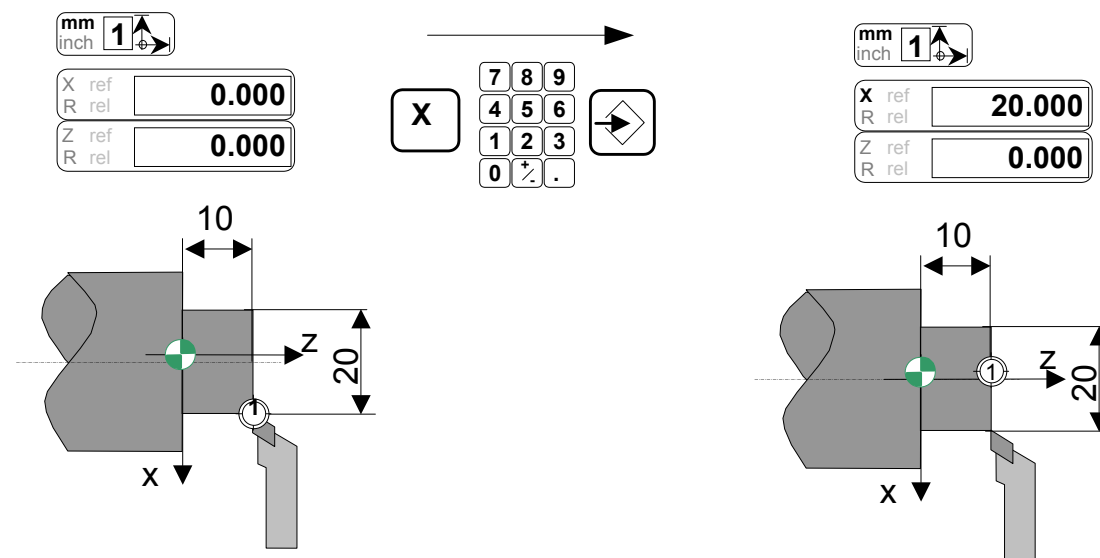

In the above example, the device will enter the following value of parameter P91: P91x=20.000, P91z = 0.000. You can check it by selecting this parameter.

PROCEDURE	DISPLAY	NOTE
		Device is set to absolute mode, datum point 1; no axis is selected.
	Axis indicator light steady	Choose the axis in which you like to preset new absolute position
	Axis indicator light steady; Decimal point on last typed digit pulsate	On numerical keyboard type the required new absolute position
	New position is displayed	Confirmation of new DP 1 position. The previous offset of DP 1 is lost. The new datum point offset is calculated and entered in P101 parameter.
	No number on the axis display	Deleting of typed numbers due to typing failure, or other reason
	Old absolute position	Abandon of absolute position preset; Old absolute position is maintained.
		Device is set to absolute mode, datum point 1; X axis is selected

5.2.7.3. DATUM POINTS SETTING BY MANUAL PARAMETER ENTRY

The entry is similar as for the other parameters (Item 4.1):

5.3. RELATIVE MODE

The relative mode is useful, when machining parts according to drawings where measures are made in relative manner (sketch bellow). Absolute position in relative mode is not lost, only displayed position when entrance in relative mode is 0.000. Abandon of relative mode will set NP20 in to a absolute mode, and position according to old absolute coordinate system will be displayed.

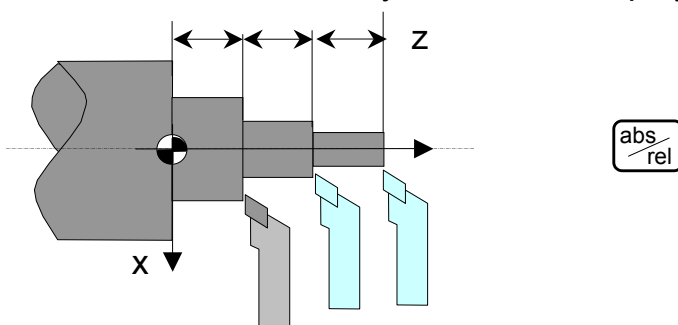

Pressing to key abs/rel does toggle from absolute mode to relative mode.

Relative mode is indicated by “rel” indications on the axis status display.

Procedure is shown bellow:

PROCEDURE	DISPLAY	NOTE
		Device is set to absolute mode; no axis is selected.
	Axis indicator light steady	Select the axis, which you like to set in relative mode. If no axis is selected, settings to relative mode are valid for all axes.
	Position display of selected axis is set to 0.000 ; “rel” indicator lights steady	Setting into a relative mode
Operation in relative mode	Position display follow relative position	Position display follow relative position based on relative origin
	“rel” indicator switch off; position display shows absolute position	Abandon of relative mode. Position display shows absolute position based on an absolute origin

In relative mode is admissible to make radius-diameter toggle, mm – inch conversion and freeze the position display. Reset or preset of position in relative mode set the NP20 in “distance to go” mode.

5.4. DISTANCE TO GO mode

Distance to go mode is purposed to simplify positioning operation on the machine tool. Operator simply (through specified procedure) enters the wished absolute position, and position display of selected axis show you distance remaining to target position. When position display shows “0.000” target absolute position is reached.

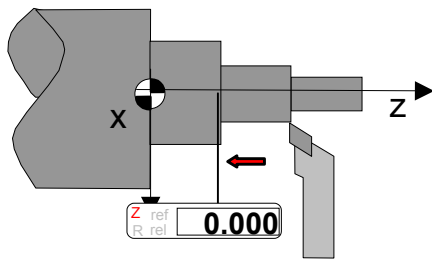

Into “distance to go” mode is possible to enter from absolute mode through relative mode and presetting in relative mode target position.

Procedure is described in the diagram bellow:

PROCEDURE	DISPLAY	NOTE
		Device is set to absolute mode; no axis is selected.
	Rel indications light steady; position display (s) is set to 0.000	Entrance into the relative mode.
	Axis indicator light steady;	Choose the axis which will be position by “distance to go” mode
	Decimal point on last typed digit pulsate	Type in a target absolute position. Position display shows typed numbers
	Distance to target position is displayed	Confirmation of typed target absolute position. After confirmation distance from current to target position is shown
	No number on the axis display	Deleting of typed numbers due to typing failure, or other reason
	Old relative position	Abandon of target absolute position preset; Device is set to relative mode.
	Distance to target position is shown	Driving toward zero value on the display
	Displayed position on selected axis is zero	Target position is reached
	Rel indications switch off, target absolute position is displayed	Device is toggled to Absolute mode Target absolute position is displayed
		Device is set to absolute mode, X axis is selected

5.5. AXIS SHIFT VELOCITY MEASURING MODE

In axis shift velocity, measuring mode position displays shows axis shift velocity. The velocity is indicated in m/min or in inch/min, depending of the selected measuring units (mm or inch).

This mode is useful for settings of optimal and repeatable turning conditions.

When velocity mode is selected, it is valid for both axes. Abandon of this mode is done by key "DELETE".

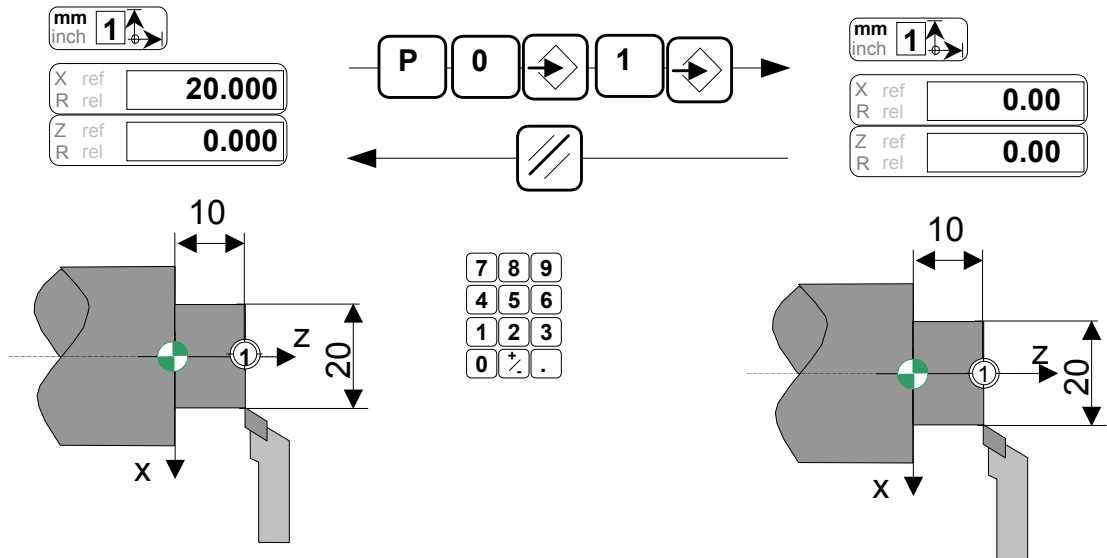

6. SERIAL DATA TRANSFER

6.1) Cabels for connection with PC and Printer

NP 30 RS 232 connector (9-pol D-SUB male)			PRINTER RS 232 (25-pol D-SUB male)			IBM PC RS232 (25-pol D-SUB female)			IBM PC RS 232 (9-pol D-SUB female)		
Pin	Signal	Cool	Pin	Signal	Cool	Pin	Signal	Cool	Pin	Signal	colour
1	GND	shield	1	GND	Shield	1	GND	Shield	1	GND	Shield
2	RxD	Red	2	TxD	Red	2	TxD	Red	3	TxD	Red
3	TxD	White	3	RxD	White	3	RxD	White	2	RxD	White
4	-	-									
5	GND	Black	7	GND	Black	7	GND	Black	5	GND	Black
6	-	-									
7	CTS	Green	5	RTS	Green						
8	RTS	Yellow	20	CTS	Yellow	20	CTS	Yellow	4	CTS	Yellow
9											

6.2) Structure of serial data and baud rates

Baud rates are set by parameter P7. Possible baud rates are: 300, 600, 1200, 2400, 4800, and 9600.

Data is received and transmitted in following data format (1start bit, 8data bits, 1stop bit, no parity):

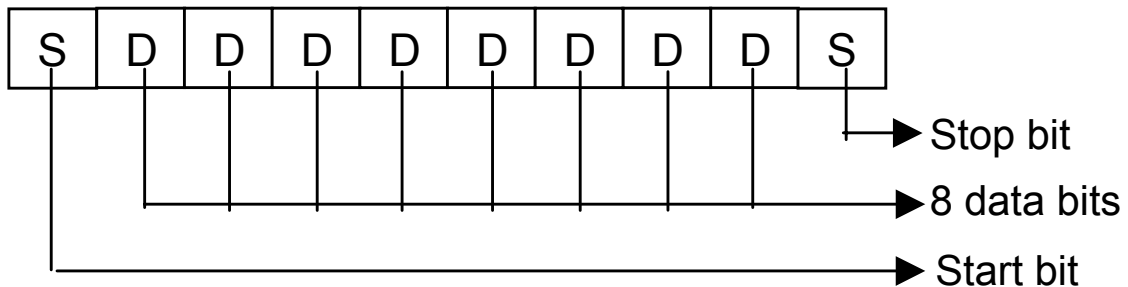

6.3) Data transfer command and output shapes:

6.3.1) Transfer of label data:

This transfer can be initialised:

- by typing keys <P> <ENTER> on the NP 30 keyboard or,
- by sending a CTRL B ASCII character (hex code \$02) through RS232 channel.

After initialisation NP 30 will send a following data (message start with CR and end with number of LF which is define in parameter P8):

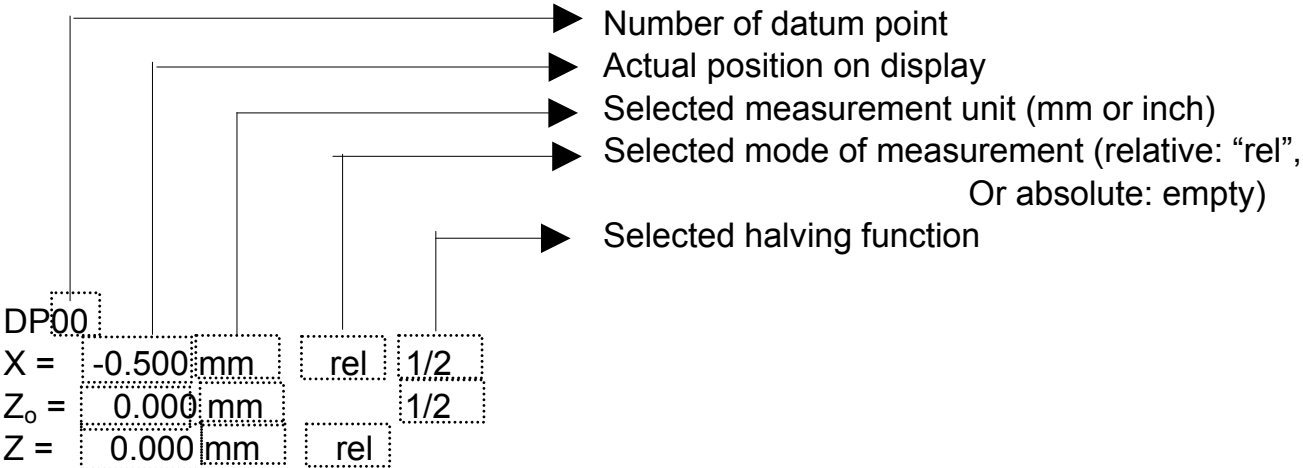

6.4) Transfer of current position

This transfer can be initialised:

- by sending a CTRL H ASCII character (hex code \$08) through RS232 channel.

After initialisation NP 30 will send a following data:

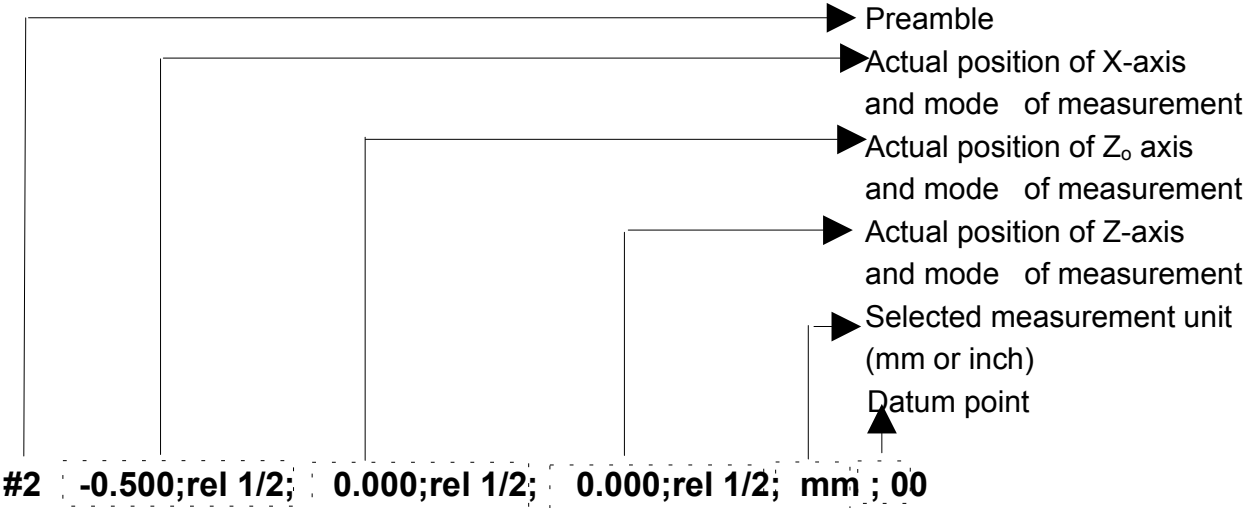

7. FAILURE DIAGNOSTICS

With a purpose to assure stable, safety and accurate operation of measuring system on the machine tool, NP20 device is equipped with several diagnostic functions.

Failure diagnostic functions in the case of any irregularity in operation of NP20, or periphery units, which are connected to it (linear or rotary encoders), warn the operator by message on the position display(s).

Proper procedure, when warning message is displayed will avoid expenses caused by improper machining, and simplify repair or maintenance operation.

After switch on, during initialisation procedure for approx. 0,5 sec all segments of light elements are switch on, with purpose to recognise if some light elements is out of function.

<Err tyPE> This message is displayed if operator type a command which can't be executed or which is out of sense.

Example: NP20 is set to axis shift velocity mode, operator press the key "REL" – message **Err tyPE** will be displayed, and disappear after 1 second.

<Err 1> Two neighbouring edges of input signals A and B are to close together. This message can be caused by:

- Exceeding of maximal axis shift velocity;
- Influence of Electromagnetic disturbances on measuring system or any of its component (linear or rotary encoder, DRO);
- Linear encoder installation (alignment) is not properly done;
- Machine guide ways are looseness;

Message can be deleted by pressure to key "DELETE". If any other reason except exceeding of velocity caused this message maintenance/repair activities should be done.

This diagnostic function is available upon a special order.

<Err 2> Position measuring error. Difference of Absolute positions during current and previous pass over reference mark (in increments) is bigger then value, which is set to parameter **P6**.

If absolute coordinate system is not calibrated diagnostic is active.

If value of P6 is set to 0, this diagnostics is inactive.

If distance coded reference is used this diagnostics is active.

Possible reasons for this failure:

- Settings of parameter P15 or P16 (define type of reference mark) does not correspond to used linear encoder;
- Use of encoders with multiple reference marks;
- Exceeding of maximal axis shift velocity;
- Influence of Electromagnetic disturbances on measuring system or any of its component (linear or rotary encoder, DRO);

- Linear encoder installation (alignment) is not properly done;
- Machine guide ways are looseness;

Err 2 message can be deleted by key “DELETE”, position display of axis in which failure was happened will show the value (in increments) of difference in absolute position between current and previous pass, press to key “DELETE” will return NP20z to the mode which was set before failure happened. See diagram:

PROCEDURE	DISPLAY	NOTE
		Pass over a reference mark
	“Err 2« message appears on the failed axis	Absolute position during current pass over the reference mark is different then during previous pass
	On the position display of failed axis number is shown	This number is difference in increments between absolute position and previous position
	Position display shows position	NP 20 is set to mode which was selected before failure happened. Position displays shows position. Old absolute position in failed axis is lost. If axis was calibrated it became non-calibrated.

<Err 3> A damage of one or multiple memory cells in internal structure of E²PROM. The parameter storing is not stable.

This failure can be caused by too often changing of parameters value (>150.000). During normal operation, calculated lifetime for internal E²PROM is more then 41 years.

<Err 4> Counting logics error. This failure can be caused by:

- Settings of parameter P02 to any value if NP20 is not equipped with option Q or Z (auxiliary axis);
- Break down of electronic component(s)

<Err 5> Break down of internal RAM circuit.

<Err 6> Calculating error (exceeded max. arithmetic value)

<Err PAr> One or several positioning parameters have not been entered (display X)

<Err SOFT> Error in the device software

8. TECHNICAL DATA

Power supply voltage:	220 V +10% - 15%
On request:	110 V +10% - 15%
Network frequency:	48 to 52 Hz
Power consumption:	20 VA approx.
Ambient operating temperature:	0 to 45°C
Relative humidity:	5 to 75%
Protection degree:	54 (front plate, housing) IP 42 (rear plate)
Vibrations*	1 g from 10 to 150 Hz
Shocks*:	15 g
Power cable interferences*:	symmetrical 2.5 kV asymmetrical 2.5 kV
EM field*:	10 V/m from 27 MHz to 200 MHz
Electrostatic discharge*:	13 kV
Safety class:	group 1 according to IEC 348
Dimensions (width x height x depth):	250 mm x 163 mm x 126 mm
Weight:	cca. 2.200 g

***NOTE:** Tested according to the IEC standards.

SQUARE-WAVE MEASURING SIGNALS:

RS-422-A, EIA standards,	12-pole connector
Max. signal frequency:	120 kHz

9. FRONT AND REAR PLATE – OPERATING ELEMENTS

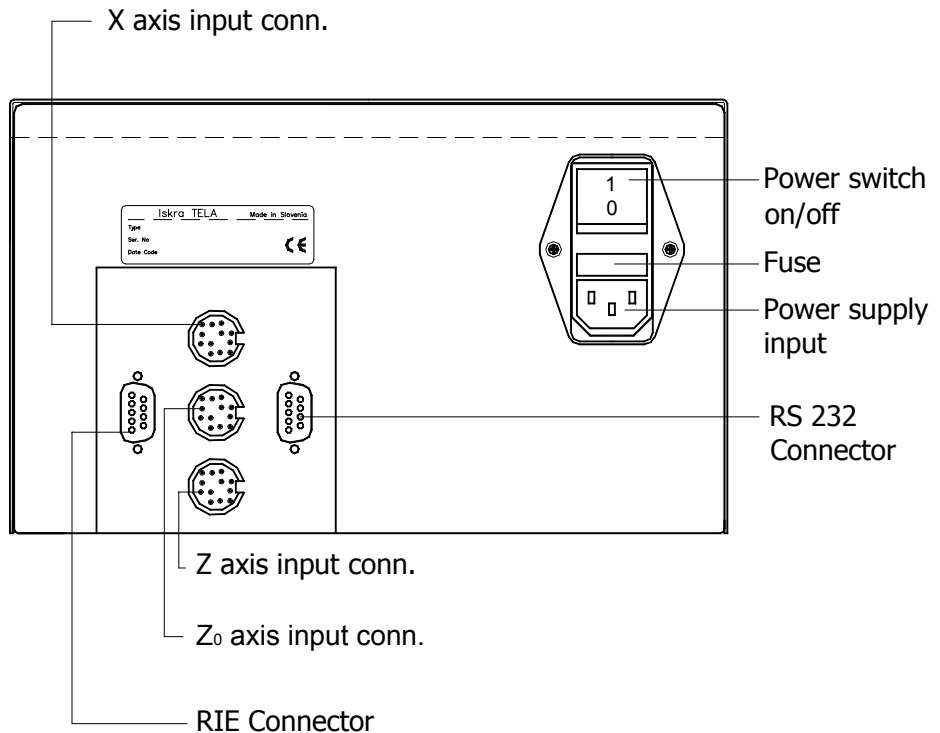
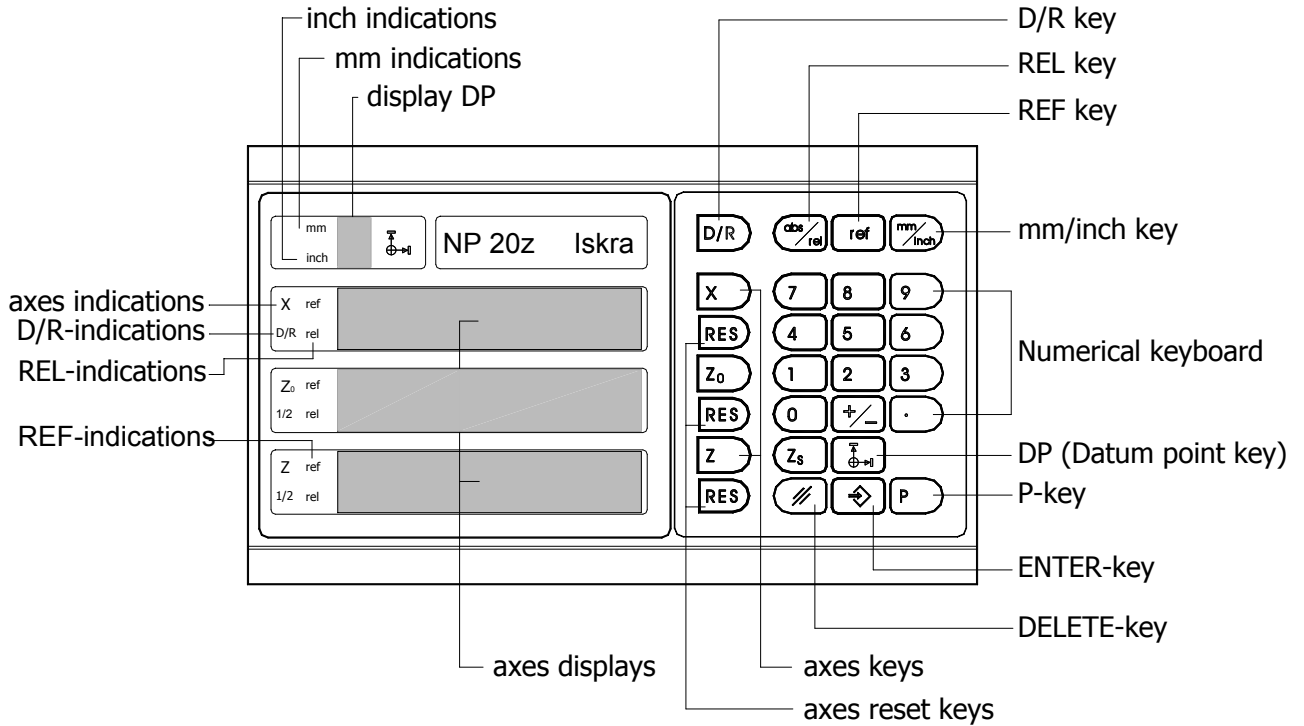

Clearance of at least 120 mm has to be provided for accommodating the electrical connections at rear of the device.

NOTES:
