

9060 HIGH VOLTAGE CONTROLLER for No. 2 Process™ Handgun (HV2 - Electric Motor)



MODEL: 80102-21X (Electric Motor)

IMPORTANT: Before using this equipment, carefully read **SAFETY PRECAUTIONS**, starting on page 1, and all instructions in this manual. Keep this Service Manual for future reference.

Service Manual Price: \$50.00 (U.S.)

CONTENTS

	PAGE
SAFETY:	1-6
SAFETY PRECAUTIONS	1
HAZARDS / SAFEGUARDS.....	2-5
INTRODUCTION:	7-12
GENERAL DESCRIPTION.....	7
SAFETY FEATURES	7
DISPLAYS	7
SPECIFICATIONS	8
CONTROLLER FEATURES.....	9
OPERATOR INTERFACE.....	10
SWITCHES.....	10
LEDS	10
BUTTONS.....	10-11
CONNECTION INTERFACE	11
CONNECTORS.....	11
FUSES.....	11
SIGNAL INTERFACE.....	12
INSTALLATION:	13-15
GENERAL INFORMATION	13
LOCATION.....	13
AC INPUT CONNECTIONS	13-14
SAFETY GROUND	14
INPUT VOLTAGE SELECTION	14
HIGH VOLTAGE CABLE.....	14
NO. 2 PROCESS HANDGUN TRIGGER SIGNAL	15
OPERATION:	16-20
START-UP	16
BASIC OPERATIONS.....	16-17
KV TEST JUMPER	17
SETPOINT OPERATIONS.....	17
FAULTS	18
FAULT DESCRIPTIONS.....	18-19

CONTENTS

	PAGE
MAINTENANCE:	21-32
ROUTINE PREVENTIVE MAINTENANCE.....	21
TROUBLESHOOTING	21-22
FAULT TROUBLESHOOTING GUIDE.....	23-24
GENERAL TROUBLESHOOTING GUIDE	25-26
SERVICE LEVEL	27
REPLACEMENT PROCEDURES	27-31
PARTS IDENTIFICATION:	33-34
HIGH VOLTAGE CONTROLLER MODEL IDENTIFICATION	33
PARTS LIST	34
ACCESSORIES:	35
ACCESSORIES LIST.....	35
WARRANTY POLICIES:	36
LIMITED WARRANTY	36

Ransburg

SAFETY

SAFETY PRECAUTIONS

Before operating, maintaining or servicing any Ransburg electrostatic coating system, read and understand all of the technical and safety literature for your Ransburg products. This manual contains information that is important for you to know and understand. This information relates to **USER SAFETY** and **PREVENTING EQUIPMENT PROBLEMS**. To help you recognize this information, we use the following symbols. Please pay particular attention to these sections.

A WARNING! states information to alert you to a situation that might cause serious injury if instructions are not followed.

A CAUTION! states information that tells how to prevent damage to equipment or how to avoid a situation that might cause minor injury.

A NOTE is information relevant to the procedure in progress.

While this manual lists standard specifications and service procedures, some minor deviations may be found between this literature and your equipment. Differences in local codes and plant requirements, material delivery requirements, etc., make such variations inevitable. Compare this manual with your system installation drawings and appropriate Ransburg equipment manuals to reconcile such differences.

Careful study and continued use of this manual will provide a better understanding of the equipment and process, resulting in more efficient operation, longer trouble-free service and faster, easier troubleshooting. If you do not have the manuals and safety literature for your Ransburg system, contact your local Ransburg representative or Ransburg.



WARNING

► The user **MUST** read and be familiar with the Safety Section in this manual and the Ransburg safety literature therein identified.



► This manual **MUST** be read and thoroughly understood by **ALL** personnel who operate, clean or maintain this equipment! Special care should be taken to ensure that the **WARNINGS** and safety requirements for operating and servicing the equipment are followed. The user should be aware of and adhere to ALL local building and fire codes and ordinances as well as **NFPA-33 SAFETY STANDARD**, prior to installing, operating, and/or servicing this equipment.





WARNING

► The hazards shown on the following page may occur during the normal use of this equipment. Please read the hazard chart beginning on page 2.

AREA Tells where hazards may occur.	HAZARD Tells what the hazard is.	SAFEGUARDS Tells how to avoid the hazard.
<p>Spray Area</p> 	<p>Fire Hazard</p> <p>Improper or inadequate operation and maintenance procedures will cause a fire hazard.</p> <p>Protection against inadvertent arcing that is capable of causing fire or explosion is lost if any safety interlocks are disabled during operation. Frequent Controller shutdown indicates a problem in the system requiring correction.</p>	<p>Fire extinguishing equipment must be present in the spray area and tested periodically.</p> <p>Spray areas must be kept clean to prevent the accumulation of combustible residues.</p> <p>Smoking must never be allowed in the spray area.</p> <p>The high voltage supplied to the atomizer must be turned off prior to cleaning, flushing or maintenance.</p> <p>When using solvents for cleaning:</p> <p>Those used for equipment flushing should have flash points equal to or higher than those of the coating material.</p> <p>Those solvents used for cleaning must have a flash point at minimum of 5°C (9°F) greater than ambient temperature. It is the end users responsibility to ensure this condition is met.</p> <p>Spray booth ventilation must be kept at the rates required by NFPA-33, OSHA, and local codes. In addition, ventilation must be maintained during cleaning operations using flammable or combustible solvents.</p> <p>Electrostatic arcing must be prevented.</p> <p>Test only in areas free of combustible material.</p> <p>Testing may require high voltage to be on, but only as instructed.</p> <p>Non-factory replacement parts or unauthorized equipment modifications may cause fire or injury.</p> <p>If used, the key switch bypass is intended for use only during setup operations. Production should never be done with safety interlocks disabled.</p> <p>Never use equipment intended for use in waterborne installations to spray solvent based materials.</p> <p>The paint process and equipment should be set up and operated in accordance with NFPA-33, NEC, and European Health and Safety Norms.</p>

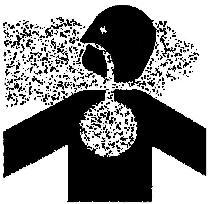
<p>AREA</p> <p>Tells where hazards may occur.</p>	<p>HAZARD</p> <p>Tells what the hazard is.</p>	<p>SAFEGUARDS</p> <p>Tells how to avoid the hazard.</p>
<p>Spray Area</p> 	<p>Fire and/or explosion.</p>	<p>Electrostatic arcing MUST be prevented.</p> <p>The 78789 control panel, LEPS5001 power supply and all other electrical equipment must be located outside Class I or II, Division 1 or 2 hazardous areas, in accordance with NFPA-33.</p> <p>Test only in areas free of flammable or combustible materials.</p> <p>The current overload sensitivity MUST be set as described in the OVERLOAD ADJUSTMENT Procedures section of this manual. Protection against inadvertent arcing that is capable of causing fire or explosion is lost if the current overload sensitivity is not properly set. Frequent power supply shutdown indicates a problem in the system which requires correction.</p> <p>Always turn the control panel off prior to flushing, cleaning, or working on spray system equipment.</p> <p>Ensure that the control panel is interlocked with the ventilation system and conveyor in accordance with NFPA-33, EN 50176.</p> <p>Have fire extinguishing equipment readily available and tested periodically.</p>
<p>General Use and Maintenance</p> 	<p>Improper operation or maintenance may create a hazard.</p> <p>Personnel must be properly trained in the use of this equipment.</p>	<p>Personnel must be given training in accordance with the requirements of NFPA-33, EN 60079-0.</p> <p>Instructions and safety precautions must be read and understood prior to using this equipment.</p> <p>Comply with appropriate local, state, and national codes governing ventilation, fire protection, operation maintenance, and housekeeping. Reference OSHA, NFPA-33, EN Norms and your insurance company requirements.</p>

AREA Tells where hazards may occur.	HAZARD Tells what the hazard is.	SAFEGUARDS Tells how to avoid the hazard.
<p>Electrical Equipment</p> 	<p>High voltage equipment is utilized. Arcing in areas of flammable or combustible materials may occur. Personnel are exposed to high voltage during operation and maintenance.</p> <p>Protection against inadvertent arcing that may cause a fire or explosion is lost if safety circuits are disabled during operation.</p> <p>Frequent power supply shut-down indicates a problem in the system which requires correction.</p> <p>An electrical arc can ignite coating materials and cause a fire or explosion.</p>	<p>The power supply, optional remote control cabinet, and all other electrical equipment must be located outside Class I or II, Division 1 and 2 hazardous areas. Refer to NFPA-33 or EN 50176.</p> <p>Turn the power supply OFF before working on the equipment.</p> <p>Test only in areas free of flammable or combustible material.</p> <p>Testing may require high voltage to be on, but only as instructed.</p> <p>Production should never be done with the safety circuits disabled.</p> <p>Before turning the high voltage on, make sure no objects are within the sparking distance.</p>
<p>Toxic Substances</p> 	<p>Certain material may be harmful if inhaled, or if there is contact with the skin.</p>	<p>Follow the requirements of the Material Safety Data Sheet supplied by coating material manufacturer.</p> <p>Adequate exhaust must be provided to keep the air free of accumulations of toxic materials.</p> <p>Use a mask or respirator whenever there is a chance of inhaling sprayed materials. The mask must be compatible with the material being sprayed and its concentration. Equipment must be as prescribed by an industrial hygienist or safety expert, and be NIOSH approved.</p>

AREA Tells where hazards may occur.	HAZARD Tells what the hazard is.	SAFEGUARDS Tells how to avoid the hazard.
<p>Spray Area / High Voltage Equipment</p> 	<p>There is a high voltage device that can induce an electrical charge on ungrounded objects which is capable of igniting coating materials.</p> <p>Inadequate grounding will cause a spark hazard. A spark can ignite many coating materials and cause a fire or explosion.</p>	<p>Parts being sprayed must be supported on conveyors or hangers and be grounded. The resistance between the part and ground must not exceed 1 megaohm. (Reference NFPA-33 or EN 50176)</p> <p>All electrically conductive objects in the spray area, with the exception of those objects required by the process to be at high voltage, must be grounded.</p> <p>Any person working in the spray area must be grounded.</p> <p>Unless specifically approved for use in hazardous locations, the power supply and other electrical control equipment must not be used in Class 1, Division 1 or 2 locations or Class 1, Zone 0 for European Applications.</p>

NOTES

INTRODUCTION

GENERAL DESCRIPTION

The Ransburg No. 2 Handgun Process

The No. 2 Process™ is an electrical atomization method for applying coatings to objects electrostatically. The No. 2 Process Handgun system applies a high voltage, negative, DC charge to the applicator bell, creating an electrostatic field between the bell and the target object. The target is electrically grounded through its support which may be stationary or moving; or through an electrical connection to a known true earth ground.

A regulated pressure fluid system delivers coating material to the bell when the gun is triggered. There, the fluid travels across the face of the rotating bell and becomes charged. The fluid is electrically atomized at the edge of the bell forming a fine mist which, under the influence of the electrostatic field, is attracted to and deposited on the target object. The forces between the charged particles and the grounded target are sufficient to turn almost all overspray around and deposit it on the side and back surfaces of the target. Thus, a high percentage of the spray is deposited on the target and overspray is controlled.

The 9060 High Voltage Controller

The *Ransburg 9060 High Voltage Controller* (80102-21X) is used to provide high voltage for the No. 2 Process Handgun. It uses a combination of proven high voltage generation technology and microprocessor-based control. It uses current feedback information to maintain the required kV output for the No. 2 Process Handgun. The processor circuitry provides the maximum in applicator transfer efficiency, while maintaining the maximum safety.

The 9060 Controller for the No. 2 Process

Handgun has a fixed setpoint value which can **NOT** be adjusted. The triggering of the HV is initiated by the on-off switch on the No. 2 Process Handgun. For more information, please refer to the “Theory of Operation” in the “Operation” section of this manual.

SAFETY FEATURES

The Ransburg 9060 High Voltage Controller provides maximized operational safety. The protections include detection of Ground Faults, Cable Faults, Feedback Signal Fault, Current Limit Fault and Overvoltage Fault. The microprocessor circuits provide a controlled output load curve, which limits the high voltage output to safe levels while monitoring control and feedback signals for unsafe conditions. Maximum operational safety is obtained when the correct applicator settings are used and when safe distances between the applicator and target are observed and followed. The maximum efficiency of the high voltage controller is based on load.

DISPLAYS

The front panel displays the high voltage setpoint as well as a reading of the gun current output. The gun current is derived from feedback signals between the controller and the cascade.



Figure 1: 9060 High Voltage Controller (HV2)

NOTE

► The 9060 High Voltage Controller is factory supplied with a latch (#E5-1-065-091) that can be opened using the supplied key (#E3-2).

The 9060 High Voltage Controller is available as follows:

9060 Part No.	Used with No. 2 Gun Type	Gun No.
80102-211	Electric Motor, Domestic	19372-XX
80102-212	Electric Motor, European	19372-XX
80102-213	Electric Motor, China	19372-XX

SPECIFICATIONS

Environmental

Operating Temperature: 0°C to +40°C

Storage and Shipping Temperature: -40°C to +85°C

Humidity: 95% Non-Condensing

Physical

Height: 16.5 cm (6.5 inches)

Width: 37.8 cm (14.9 inches)

Depth: 30.7 cm (12.1 inches)

Weight: 10.2 kg (22.5 lbs.)

Electrical

Input:

Voltage: 100-240 VAC
Current: 1 A max. RMS
Frequency: 50/60 Hertz
Wattage: 40 watts (max.)

Output:

Voltage: 100 kV (80102-21X)
Current: 115 Microamps Max.

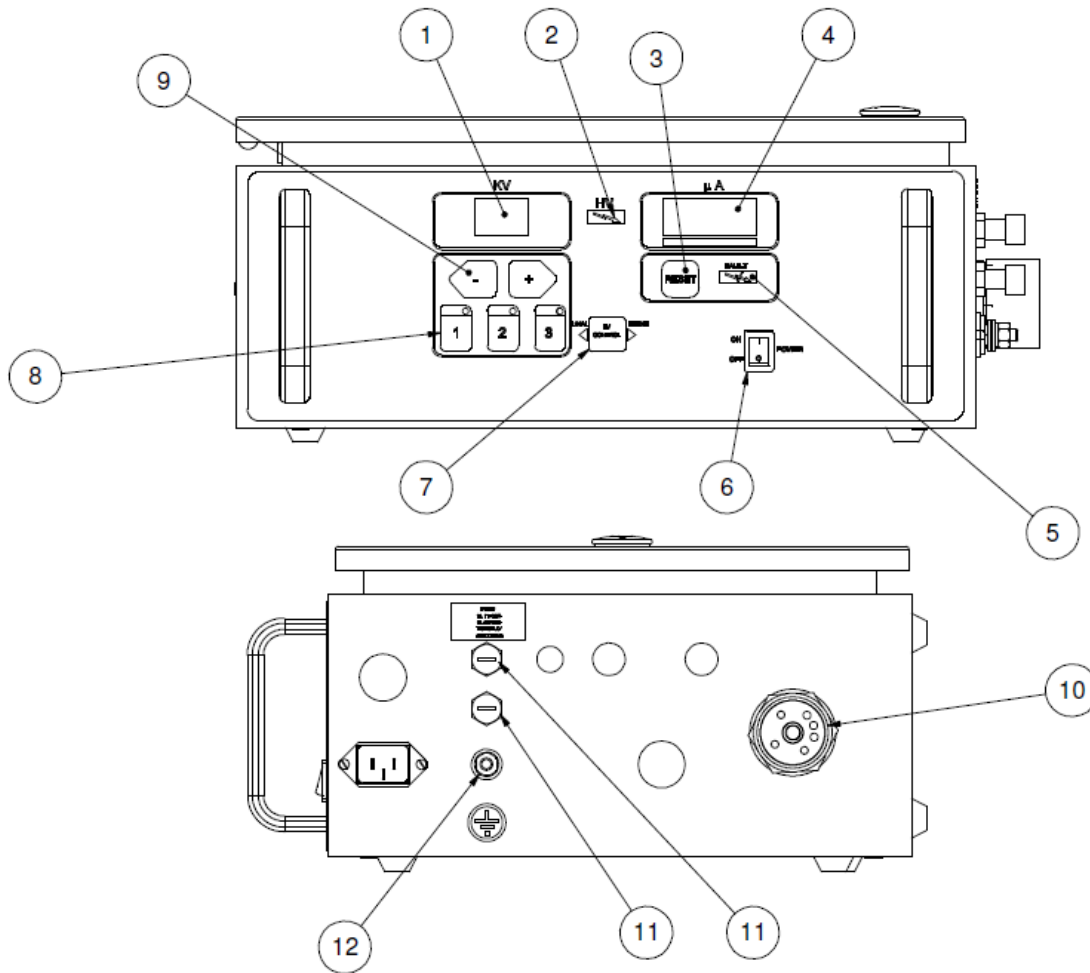

Figure 2: 9060 High Voltage Controller Features

9060 CONTROLLER FEATURES			
No.	Description	No.	Description
1	kV Display	9	kV Setpoint/Adjust Buttons (<i>reference</i>)
2	High Voltage On Indicator	10	High Voltage Cable Connector
3	Reset Button	11	Fuses
4	μA Display	12	Ground Lug
5	Fault Indicator	13	AC Inlet Receptacle
6	On-Off Switch		
7	Local/Remote Mode Indicator (<i>reference</i>)		
8	“One Touch” kV Setpoint Buttons (<i>reference</i>)		

OPERATOR INTERFACE

The 9060 Controller shown in Figure 3, has a simple operator interface consisting of 7 LEDs (Light Emitting Diodes), one (1) power switch, seven (7) buttons, one (1) current LED bargraph, and two (2) screens containing seven-segment displays. The following describes the behavior of the interface components used with the No. 2 Process Handgun.

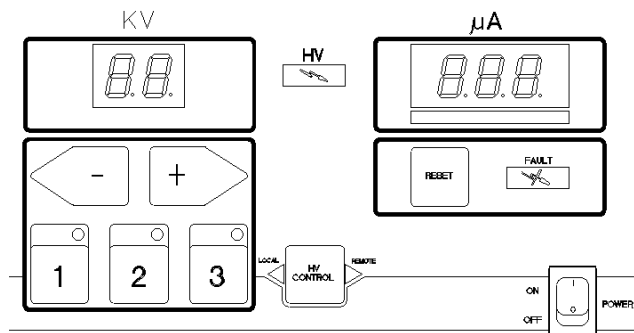

Figure 3: 9060 Operator Interface

SWITCHES

Power Switch

The 9060 Controller contains a single rocker switch for power On/Off selection. When the unit is powered on, the screens should be lit and display the gun display type information and the software version number for a short period of time.

LEDs

High Voltage On Indicator

The red High Voltage On Indicator is lit when a trigger signal has been received by the unit and the high voltage output from the cascade has been enabled.

Fault Indicator

The red Fault Indicator is lit when a fault occurs as determined by the microprocessor. When a fault occurs the light will turn on and the identification code for the fault will be displayed, blinking, on the μA meter display. For more information on the faults and fault ID codes,

please refer the Fault Descriptions section in the Operations portion of this manual.

Local Mode LED Indicator

The local mode LED indicator is a left pointing triangle and is located on the left side the HV control button on the center of the operator interface. This LED is lit when the Controller is used with the No. 2 Process Handgun.

Remote Mode LED Indicator

The remote mode LED indicator should **NOT** be lit for No. 2 Process Handgun units.

Active Preset LED Indicators (3)

The active preset LED indicators are located directly above each of the Preset Buttons. The No. 2 Process Handgun (80102-21X) is designed to operate at only one specific setpoint, therefore these LEDs only indicate which of the 3 buttons was the last button pressed and have no affect on the setpoint for the No. 2 Handgun.

BUTTONS

The seven buttons on the operator interface are normally used to adjust the KV preset, access submenus, view operating hours and reset overloads and faults. The No. 2 Process Handgun only uses a subset of the 9060 High Voltage Controllers functionality and the following lists the behavior for each button when the unit is configured for the No. 2 Process Handgun.

Preset 1 Button

The Preset 1 Button (on the left just below the kV display) if pressed with the reset button at the same time, the screen will display the resettable High Voltage ON operating hours for 3 seconds on the display screens. The preset 1 button will **NOT** affect the setpoint of the No. 2 Process Handgun.

Preset 2 Button

The Preset 2 Button (in the center below the kV display) if pressed with the reset button at the same time, the screen will display the non-resettable High Voltage ON operating hours for

3 seconds on the display screens. The preset 2 button will NOT affect the setpoint of the No. 2 Process Handgun.

Preset 3 Button

The Preset 3 Button (on the right side below the kV display) has NO functionality when the 9060 is configured for used with the No. 2 Process Handgun. The preset 3 button will NOT affect the setpoint of the No. 2 Process Handgun.

Left (-)/Right (+) Buttons

The left(-)/right(+) buttons have NO functional behavior when the 9060 is configured for use with the No. 2 Process Handgun and CAN NOT modify the setpoint.

Reset Button

The reset button is used to clear fault or over-load conditions. This will NOT prevent any other active fault conditions from triggering a new fault.

HV Control Button

This button, shown in the center of Figure 3, has no currently defined behavior. The unit is placed in LOCAL mode at power-on and should remain in LOCAL mode while the unit is configured for use with the No. 2 Process Handgun.

CONNECTION INTERFACE

The 9060 Controller connection interface shown in Figure 4, provides all of the required connections for setting up a No. 2 Process Handgun (80102-21X). This connection interface consists of one (1) high voltage cable connector, one (1) ground lug connection, two (2) fuses, and one (1) AC inlet receptacle.

CONNECTORS

High Voltage Cable Connector

The high voltage cable connector is the largest connector and is located on the far right of the connection interface. This connector is designed for use with the superflex high voltage cable 19370 that connects with the No. 2 Process Handgun.

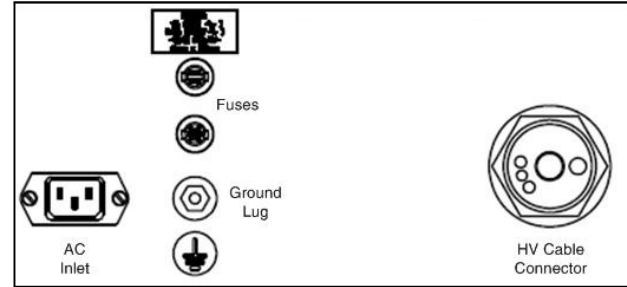

Figure 4: 9060 Connection Interface

Ground Lug Connection

The ground lug connection is located directly below the fuses and has a ground logo sticker directly below it. This lug is provided as an external ground connection point used to ground the 9060 to an earth ground via a ground cable. This ground lug connection can also be used as the ground point for the high voltage cable ground.

AC Inlet Receptacle

The AC inlet receptacle is a standard IEC C14 Appliance Inlet connector with a maximum rating of 250 VAC. It can handle both 115VAC and 230 VAC inputs at 50 or 60 Hz. The unit is shipped with the appropriate rated AC cord for the particular installation.

FUSES

Fuses

There are two (2) time delay fuses (250V, 1A, 5mm x 20mm) installed in fuse holders on the connection interface. They are located directly above the ground lug connection. They are present to provide a measure of safety against power surges through the AC input. The top fuse holder is connected in series between the HOT line (L) input connection and the Interlock AC line connection terminal 1TB-L2. The bottom fuse holder is connected in series between the neutral AC input connection and the neutral input connection of the AC line power filter.

Spare Fuses

The Controller also comes with two (2) spare fuses (250V, 1A, 5mm x 20mm) mounted in holders, inside the lid of the Controller.

SIGNAL INTERFACE

The 9060 Controller, when configured for use with the No. 2 Process Handgun, requires only one signal input for operation, the trigger signal. The trigger signal input (J3-5) is controlled from a signal output from the relay board. This output is activated when the No. 2 Process Handgun's on-off switch is turn on.

INSTALLATION

GENERAL INFORMATION

The following section contains general information on the installation of 9060 High Voltage Controller.



WARNING

- ▶ The 9060 Controller **MUST** be located a minimum of 6.1m (20') outside or away from the target being sprayed.
- ▶ The User **MUST** read and be familiar with the "Safety" section of this manual.
- ▶ This manual **MUST** be read and thoroughly understood by **ALL** personnel who operate, clean, or maintain this equipment! Special care should be taken to ensure that the warnings and requirements of operating and servicing safely are followed. The user should be aware of and adhere to ALL local building and fire codes and ordinances as well as NFPA-33, OSHA, and all related country safety codes prior to installing, operating, and/or servicing this equipment.
- ▶ Only approved applicators should be used with the 9060 High Voltage Controller.

NOTE

- ▶ As each installation is unique, this information is intended to provide general installation information for the 9060 Controller. Consult your authorized Ransburg distributor for specific directions pertaining to the installation of your equipment.

LOCATION OF THE 9060

Install the Controller in an area **must be 6.1m (20') from where the spray target is located** in accordance with federal, state, and local codes. The area should protect the Controller from the possibility of environmental intrusion (such as dust or moisture), have ambient temperatures that do not exceed 40°C, and be as close to the applicator as possible to minimize the length of the high voltage cable.



CAUTION

- ▶ **DO NOT** locate the Controller near or adjacent to heat producing equipment such as ovens, high wattage lamps, etc.

AC INPUT CONNECTIONS

For non-conduit installations, plug the detachable AC line cord into the receptacle on the side of the 9060 Controller. Plug the other end of the line cord into a properly grounded 120 volt AC outlet.

For those few installations where it is required to run the AC input wiring in conduit, perform the following:

1. **Ensure the AC line cord is unplugged** and remove the AC inlet receptacle wiring from TB1-N, TB1-L1 and TB1-EARTH GROUND (See Figures 5).
2. Remove the mounting hardware from the AC inlet receptacle and remove it from the side of Controller.
3. Install the Conduit Adapter Plate (supplied) in the hole where the AC inlet receptacle was removed (see Figure 6).
4. Install the AC input wiring (0.8mm²

(18AWG) minimum) through the Conduit Adapter Plate using conduit and wire to TB1 as follows:

Hot/Line to TB1-L1
 Neutral/Common to TB1-N
 Ground to TB1-EARTH GROUND

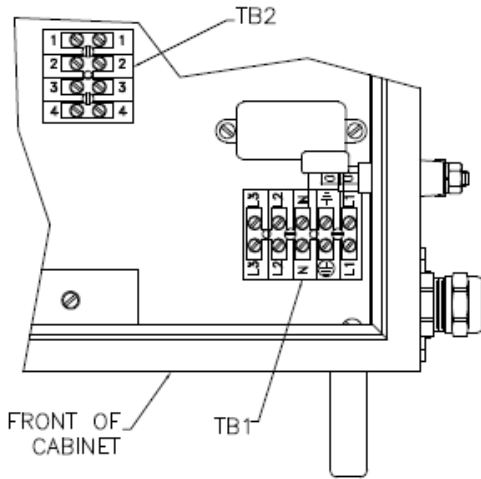

Figure 5: Location of TB1 & TB2 in Controller

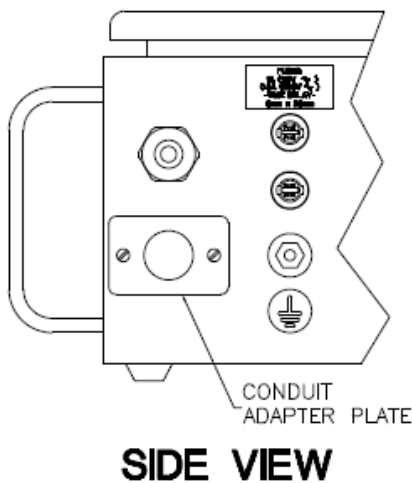

Figure 6: Installation of Conduit Adapter Plate

SAFETY GROUND

Crimp the appropriate connector onto the ground wire assembly and install from the Controller ground stud, located on the side panel, to a true earth ground.

CAUTION

▶ The ground wire assembly **MUST** be connected from the Controller ground stud to a true earth ground.

INPUT VOLTAGE SELECTION

The 9060 Controller accepts universal input voltage between 100 and 240 VAC at 50 or 60 Hz. There is no need to change any switch settings when changing input from 110 to 240 VAC or from 240 to 110 VAC.

NOTE

▶ All 9060 units (80102-21X) shipped from the factory for either 110 VAC input or 240 VAC input will have a 72771-06, 1 Amp front panel fuses installed.

HIGH VOLTAGE CABLE

Position the No. 2 Process Handgun in the spray area and route the high voltage cable to the Controller. The cable should be routed so that it is not damaged by foot and vehicle traffic and also so that it is not close to areas of high temperature (129°F+). The operator should have free movement of the applicator and all bend radii of the cable should not be less than 6 -inches (15 cm). Connect the high voltage cable to the Controller and tighten the retaining nut and set screw. If during the routing of the high voltage cable it is required to remove it from the No. 2 Handgun, care should be taken when reinstalling so that the high voltage cable is completely engaged.

WARNING

▶ The Controller **MUST** be **OFF** when the No. 2 Handgun is removed or reinstalled.

NO. 2 PROCESS HAND- GUN TRIGGER SIGNAL

The No. 2 Process Handgun (80102-21X) uses a relay board (P/N 76649-00) to provide the trigger signal output. The listed relay board is mounted on the top of the cascade casing inside the 9060 Controller chassis. When the No. 2 Process Handgun on-off switch is turned on, it activates the relay on the board which connects the trigger input (J3-5) to ground. This signal causes the PC mainboard to turn on the high voltage. For information on the replacement and wiring of a relay board, see the "Replacement Procedures" in the Maintenance Section of this Manual.

N O T E S

OPERATION

START-UP

After all installation procedures are completed, operation of the applicator may begin. When the ON-OFF switch is turned on, the kV display will show the applicator type the 9060 Controller is configured for and the μA (microamp) display will show the current software revision level as shown in Figure 7. These items are displayed for approximately 10 seconds.

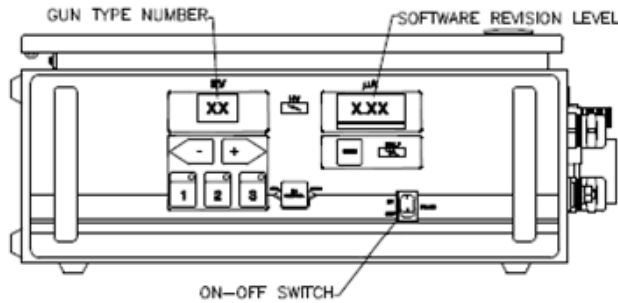

Figure 7: Controller Start-Up Display

The controller comes preconfigured for the No. 2 Process Handgun from the factory. The following table lists the display value and jumper settings for the unit. This table is a **reference** to verify that the gun configuration jumpers are in their correct positions if unexpected behavior is observed.

START-UP DISPLAY		
Type	Description	Jumpers
99	No. 2 Process Handgun (Electric Motor)	13

! WARNING

► **USE ONLY** the gun type configuration for the No. 2 Process Handgun (80102-21X). Using the wrong configuration may allow for operation outside the recommended parameters and values for the applicator and can result in **damage** or **un-safe operation**.

After the initial start-up delay, the unit will be configured for the applicator based on the gun type jumper settings and is ready for standard operation.

BASIC OPERATIONS

The basic operations are general operations that are available.

Triggering High Voltage

High voltage is actuated by the presence of an active trigger signal. This is accomplished by turning the on-off switch of the No. 2 Process Handgun to the “on” position. The kV is displayed on the kV display, the actual current draw on the μA display, and the high voltage light illuminates. Under the μA display is a bar graph meter that illuminates according to the actual current draw shown in Figure 8. The green and yellow regions of the bar graphs meter indicate output current is in the optimum range for maximum transfer efficiency. The red region of the bar graph indicates high output current causing decreased transfer efficiency. If high output, check maintenance of applicator and external equipment of the power supply.

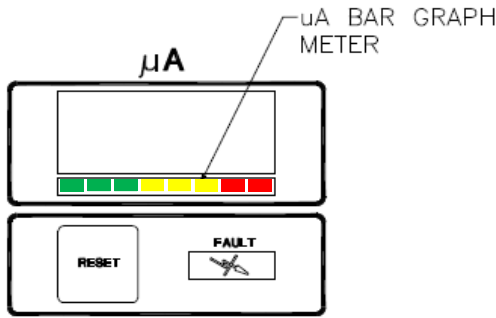

Figure 8: μ A Bar Graph Meter Display

Measuring “High Voltage On” Time

The 9060 High Voltage Controller records the amount of time the high voltage is triggered on up to 99,999 hours. This value is display on the kV and μ A displays of the unit. There are two registers that retain this information, one that may be reset, the other that is permanently retained in memory. The number of hours the unit’s high voltage has been on may be displayed by depressing at the same time the preset 1 and reset buttons (See Figure 9). The display will show hours of use for 3 seconds. This is the resettable register.

To reset this register, press the reset button while the hours are displayed.

To view the non-resettable register, press the preset 2 and reset buttons at the same time. This display will show the hours for 3 seconds.

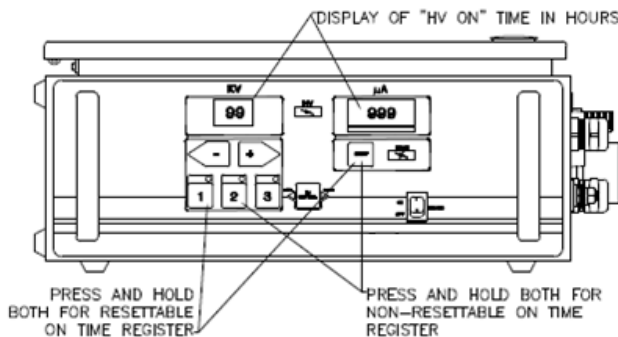

Figure 9: Display “High Voltage On” Time

KV TEST JUMPER

To assist in testing and troubleshooting, a jumper (J8) has been added to the main PC

board. By covering (shorting) both terminals of this jumper, the high voltage of the spray applicator can be activated. Thus, for testing and troubleshooting, high voltage output can be obtained without the need to trigger air through the spray applicator. **After testing, the jumper must be repositioned so that it covers only one terminal (open) or the high voltage will stay on all the time.** See Figure 10 for the location of KV test jumper J8.

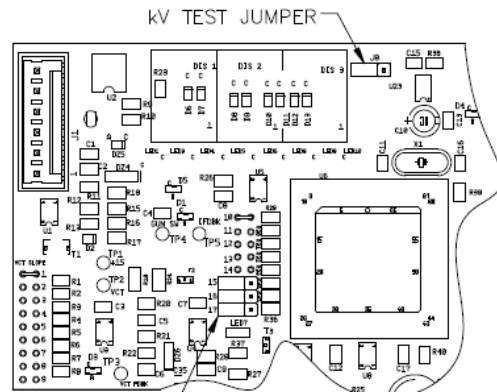

Figure 10: KV Test Jumper Location

! WARNING

➤ If jumper J8 is left covering (shorting) both terminals, high voltage will be on whenever the AC power is turned on.

NOTE

➤ Use Ransburg Calibrated Equipment **ONLY** for testing and troubleshooting. Refer to the “Parts” section of this manual for part numbers for testing equipment.

SETPOINT OPERATIONS

Voltage Setpoint

The voltage on the 9060 High Voltage Controller, when configured for use with the No. 2 Process Handgun (80102-21X), is **NOT** adjustable. The Electric Motor No. 2 Handgun is designed to operate at only a set point of 100kV. **The display will always show 99kV.**

FAULTS

Resetting Faults

During operation, various faults can occur based upon the operating conditions or if any problems with the 9060 unit arise. If a fault occurs, to reset a fault, turn off the No. 2 Handgun and press the Reset Button. This will clear the fault status and put the unit back into operation unless a fault condition is still present. Please refer to the "Fault Description" portion of the Operation Section of this Service manual for more information on a specific fault and how to correct it.

FAULT DESCRIPTIONS

For in depth troubleshooting information on the 9060, please refer to the "Fault Troubleshooting" portion of the Maintenance Section of this service manual. If a fault occurs, the Fault Indicator on the front of the Controller will light and a fault code will be displayed on the microamp display. Faults can be reset by pressing the Reset button on the front of the Controller or by using the remote I/O reset signal.

NOTE

➤ Any fault code not listed that appear on the screen are a likely indication of a PC board failure due to possible arc damage.

Cable Fault (CF)

This fault will occur if high voltage is active and the microprocessor detects that no current is being supplied to the applicator. This indicates a connection problem from the control unit to the cascade or handgun barrel assembly. Typical causes include a faulty low voltage cable, stuck pins on the plug assembly, or contaminated contacts on the applicator. This may also indicate a faulty barrel assembly for a handgun. This could also indicate a connection problem between the pc board and the high voltage section. Check the wiring harness for

loose pins, or replace the high voltage section. For additional information, refer to the Fault Troubleshooting Section.

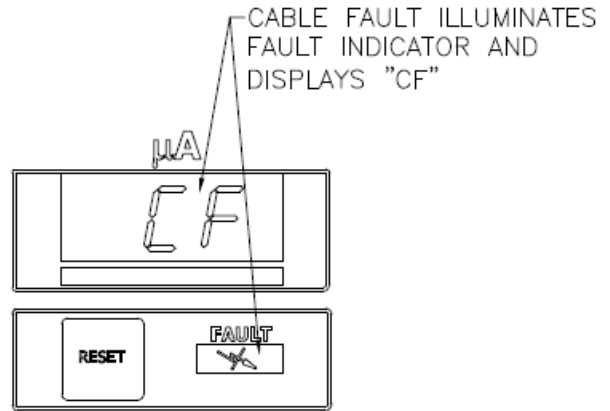

Figure 11: Cable Fault Display

Ground Fault (GF)

If this fault occurs, the fault indicator on the control unit will illuminate, a GF indication will show in the uA display. This fault will occur if the microprocessor detects a loss of ground at the high voltage section. If this fault occurs, reset the fault. This fault can be caused by a broken ground path between the applicator and the control unit and may indicate a faulty cable or plug assembly. It can also be caused by a broken ground path between the high voltage section and the pc board. Check the wiring to the high voltage section. For more information, refer to Fault Troubleshooting Section.

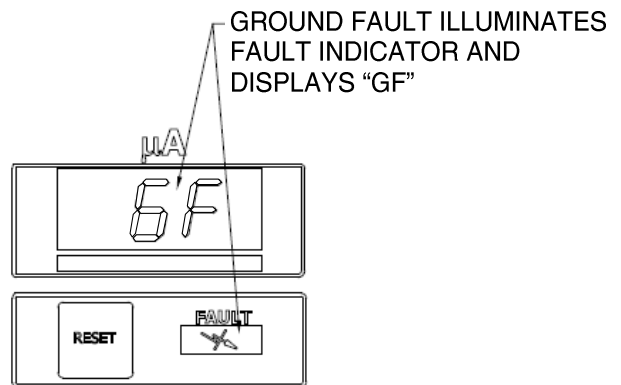

Figure 12: Ground Fault Display

Current Limit Fault (CL)

This fault occurs if the output current exceeds the maximum current by 20µA. This fault can be caused by excessive overspray on the applicator or a paint formulation that is too conductive. It may also be caused by a bad pc board. Clean the applicator, check the paint formulation, or replace the pc board. See Fault Troubleshooting Section for more information.

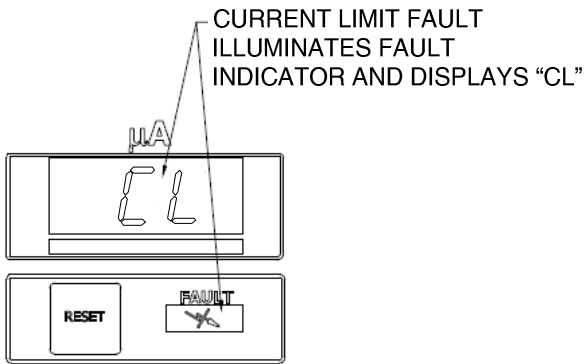

Figure 13: Current Limit Fault Display

Over Voltage Fault (OU)

This fault will occur if the microprocessor detects the unit is trying to output voltage above the required for the specific applicator type. If this occurs, reset the Controller. If this fault continues to occur, replace the main PC board.

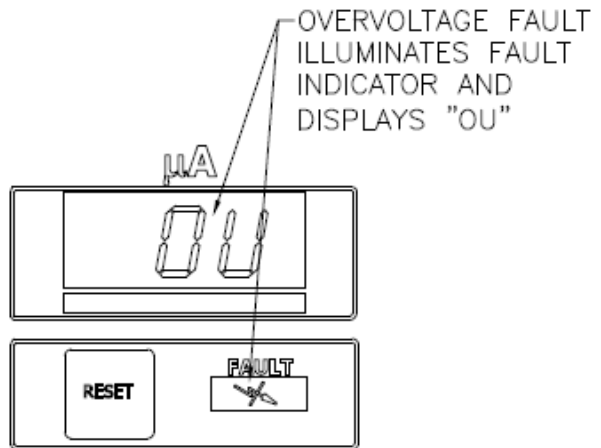

Figure 15: Over Voltage Fault Display

Voltage Cable Fault (UC)

This fault will occur if the microprocessor detects a loss of the voltage feedback signal. This can be caused by a failed high voltage cable, a failed high voltage section, or a failed pc board. Replace the high voltage cable and re-test. If still faulty, replace the high voltage section or pc board and re-test.

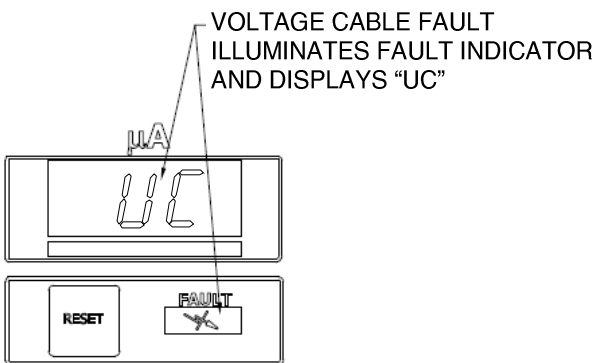

Figure 14: Voltage Cable Fault Display

Feedback Fault (FF)

This fault will occur if the microprocessor detects a loss of the current feedback signal. If this occurs, reset the fault. If this fault occurs repeatedly, refer to the Fault Troubleshooting Section to determine if the problem is with the high voltage section or the main pc board.

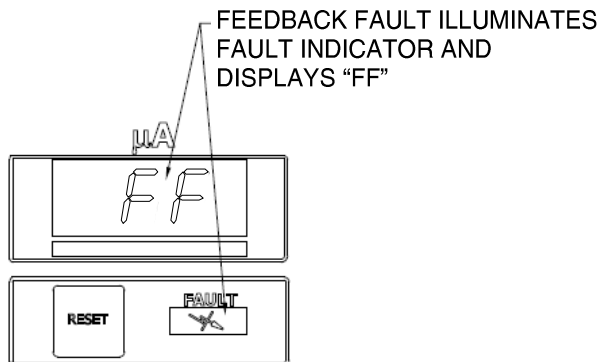

Figure 16: Current Limit Fault Display

N O T E S

MAINTENANCE

ROUTINE PREVENTIVE MAINTENANCE

In general, little maintenance is necessary to ensure proper operation. It is important, however, to keep the interior of the unit clean and free from moisture or foreign material. For this reason:

1. Keep the exterior of the unit free from dust accumulation.
2. Always clean the exterior prior to opening the cabinet door.
3. Open the cabinet door only to perform maintenance or repair.
4. If the power supply end of the high voltage cable becomes dirty, clean the end of the cable with a suitable, clean, non-polar solvent and apply a light coat of dielectric grease. On a yearly basis, check to ensure that the dielectric grease (70863-00) is covering the electrical contact point in the High Voltage Tube. If not, add grease as needed.

NOTE

► As each installation is unique, this information is intended to provide general installation information for the 9060 High Voltage Controller. Consult your authorized Ransburg distributor for specific directions pertaining to the installation of your equipment.



CAUTION

► Do not immerse any part of, or all of an assembled applicator in any liquid.

TROUBLESHOOTING

Ground Test Procedure

Equipment Required:

Ohmmeter—To Measure Resistance

If shocks or sparks are noticed at any point in the spray system, immediately turn off the power supply and check the complete system for proper grounding. Proper grounding of the spray gun system can be verified as follows:

1. Ensure that the clamp of the 14 AWG Ground Wire Assembly is connected to true earth ground. The resistance between the clamp and a known earth ground should read less than 10 ohms.
2. Place one end of the ohmmeter on the clamp of the Ground Wire Assembly and the other end on the Power Supply ground stud. If the ohmmeter reads greater than 10 ohms, replace the 14 AWG Ground Wire Assembly.
3. Connect one end of the ohmmeter to the Power Supply ground stud and the other to the metal gun handle. If the ohmmeter reads greater than 10 ohms repair or replace the high voltage cable.

KV Output Test

When a lack of high voltage at the spray gun indicates a problem, a kV Output Test of the Power Supply may be performed to help determine whether it is at fault.

Equipment Required:

Calibrated Ransburg High Voltage Test Probe and Meter (76652-01)

KV Output Test

Procedure

1. Turn AC power to the power supply **OFF**.

- Remove the high voltage (HV) cable from the power supply.

! WARNING

➤ Whenever removing high voltage cables from equipment, ground the plug end of the cable(s) by contacting the plug to electrical ground. **DO NOT** touch the plug until it has been grounded. This will eliminate the possibility of residual charge causing electrical shock.

- Open the cabinet door and position jumper J8, shown in Figure 11, on the main PC Board so that it covers (shorts) both terminals.
- Attach the appropriate HV cable to the Test Probe (76652-01), properly ground the probe to a true earth ground and turn the Test Probe Meter on (see Operation Manual of 76652-01 Tester).
- Insert the Test Probe HV cable into the Power Supply HV Tube until it bottoms out.
- Turn the power supply **ON**.
- Read the output voltage displayed on the

NOTE

➤ Ensure that the Test Probe HV cable makes good contact both inside the Test Probe and inside the Power Supply HV Tube.

meter, then turn the power supply OFF. If the voltage **DOES READ** correctly (see “Specifications” in the “Introduction” section of this manual), the problem is not in the Power Supply, therefore the HV Cable and spray gun should be checked for the cause. If the voltage **DOES NOT READ** correctly, the problem is with the power supply. Consult the “Troubleshooting Guide” to locate the specific problem.

- Disconnect the Test Probe (76652-01) and reposition jumper J8 so that it covers only one terminal. When ready to resume spray operations, reconnect the spray gun HV cable and turn the power supply on.

Bench Testing

Equipment Required:

Volt/Ohmmeter

The “Troubleshooting Guide” provides information for troubleshooting the power supply when improper operation is obtained and the problem has been traced to the power supply. Proper troubleshooting should **ONLY** be accomplished with specific test equipment by qualified electronics technicians or authorized Ransburg representatives.

Before troubleshooting, ensure that the power supply is plugged into a live outlet of appropriate voltage. All electrical measurements in the “Troubleshooting Guide” are nominal and may vary as much as $\pm 10\%$ depending on the test conditions and the test equipment used. Refer to Figure 17 for location of parts called out in the “Troubleshooting Guide”.

For bench testing, jumper J8 should be used to trigger the high voltage output (see “KV Test Jumper” previously discussed in this section).

Diagnostic LED’s

There are two diagnostic LED’s located on the relay board. LED1 is a green LED that indicates 24 VDC input is being received from power supply 2PS. LED1 should be lit whenever the power supply ON/OFF switch is ON. LED2 is a red LED that indicates 24 VDC is being output to the gun motor. LED2 should be lit whenever the toggle switch at the back of the gun is turned ON.

FAULT TROUBLESHOOTING GUIDE

WARNING

► Before troubleshooting gun and control unit problems, flush the gun with solvent and purge with air. Some of the tests will require high voltage to be applied to the gun, so the gun must be empty of paint and solvent.

Fault	Description	Solution
Cable Fault (CF)	The Cable Fault indicates the control unit does not detect a high voltage section on the end of the cable. The fault typically occurs at a high voltage trigger.	<ol style="list-style-type: none"> 1. Check for loose wiring between the pc board connector and the high voltage section by pulling on each wire. Repair if necessary. Insure both connectors are secure and re-test for CF fault. 2. Replace high voltage section or send unit in for repair. 3. Send unit in for repair.
Ground Fault (GF)	The Ground Fault is typically caused by a ground connection problem, and can create a safety hazard. It can occur without high voltage and will not reset.	<ol style="list-style-type: none"> 1. Check for loose wiring between the pc board connector and the high voltage section by pulling on each wire. Repair if necessary. Insure both connectors are secure and re-test for GF fault. 2. Adjust the setpoint to 20kV and turn on the high voltage. A GF fault indicates a faulty pc board - replace. 3. Replace high voltage section or send unit in for repair. 4. Send unit in for repair.
Over-Voltage Fault (OU)	The Over Voltage Fault indicates the output voltage exceeds the design specifications. It typically occurs during a high voltage trigger.	<ol style="list-style-type: none"> 1. Check connections using two finger pull test to ensure they are connected. 2. Replace the pc board.

Fault	Description	Solution
Over-Load Fault (OL)	The Over Load Fault indicates the current output has exceeded the overload threshold. This fault is only active if jumper 17 is shorted. The overload threshold is <u>normally</u> set at 10 μ A below the maximum output of the applicator.	<ol style="list-style-type: none"> 1. This may indicate the paint conductivity is too high (resistance too low) or the outside of the applicator is contaminated with paint.
Current Limit Fault (CL)	The Current Limit Fault indicates the current output of the gun has exceeded the maximum allowable output current. It typically occurs with the high voltage on.	<ol style="list-style-type: none"> 1. Clean outside of the applicator. 2. Replace barrel or applicator. 3. Send applicator in for repair.
Feedback Fault (FF)	The Feedback Fault indicates there is no current feedback or it is incorrect. It typically occurs with the high voltage on.	<ol style="list-style-type: none"> 1. Securely attach a ground wire to the applicator electrode. 2. Set the high voltage to maximum and short the KV test jumper. 3. The current reading on the control unit should rise up to the maximum current output. If it does not, send the applicator in for repair.
Voltage Cable Fault (UC)	The Voltage Feedback Fault indicates the cascade drive signal is not present. It typically occurs when high voltage is triggered.	<ol style="list-style-type: none"> 1. Turn off the voltage controller and remove the high voltage cable from the voltage controller. 2. Turn on the power and place a jumper across the KV Test Jumper. If the fault occurs, send the voltage controller in for repair. If no fault occurs, continue. 3. Either the high voltage cable or if using a hand gun, the gun resistor tube has failed.. If available, replace the high voltage cable, or continue to test the resistor tube. 4. To test the resistor tube, remove the resistor tube from the gun and inspect for signs of burning or arcing. Cracks or black marks indicate failure of the resistor tube, indicating the resistor tube must be replaced. Measure the resistance using a tri-meter connected to the black end of the tube and screwdriver in the other end. The measurement must be 150 to 170 Mega ohms. Replace resistor tube if the reading is not correct. 5. Replace high voltage cable or send applicator unit in for repair.

GENERAL TROUBLESHOOTING GUIDE

General Problem	Possible Cause	Solution
Black Display when from panel switch is turned to the "ON" position.	<ol style="list-style-type: none"> 1. No AC power present 2. Blown or Defective Fuse 3. Connector 7PL not properly plugged into main PC board 4. Improper input line voltage 5. Defective ON/OFF switch 1SW 6. Defective power supply 1PS 	<ol style="list-style-type: none"> 1. Ensure voltage across terminals L1 and N of terminal block 1TB is between 90 and 264 VAC. 2. Replace blown/defective fuse 3. Properly attach connector. 4. Verify connection to the voltage across terminals L2 and N of 1TB is between 90 and 264 VAC. 5. Voltage across terminals 1A and 2A of ON/OFF switch 1SW should be between 90 and 264 VAC. If not, replace switch 1SW. 6. Voltage across terminals 2 and 3 of plug 7PL on main PC board should be 24 VDC. If not, replace power supply 1PS.
Motor Rotating, But No Or Low kV Output At Spray Gun	<ol style="list-style-type: none"> 1. The connector J3 on the PC Mainboard or the connections on the relay board connector 4PL may not be properly attached to their respective locations. 2. Defective spray gun or high voltage cable. 3. Loose or broken wire in power supply. 4. Main PC board defective. 5. Defective high voltage multiplier. 	<ol style="list-style-type: none"> 1. Properly attach connector J3-5. Verify that trigger input line is connected into the 5th position from bottom of case. Verify continuity between 4PL-6 and J3-5 connector positions. Verify continuity between 4PL-7 and ground lug. 2. Perform a Current Output Test on the power supply. If proper readings are obtained, check cable or spray gun for cause. (See Spray Gun's Service Manual.) 3. Check all wiring connections for integrity. Repair wiring as needed. 4. If spare board present, replace board or Send unit in for repair. 5. Send unit in for repair.

General Problem	Possible Cause	Solution
Motor Not Rotating And No kV Output At Spray Gun, LED1 Off	<ol style="list-style-type: none"> 1. Improper or No input line voltage at 6PL 2. Defective 24 VDC power supply 2PS 	<ol style="list-style-type: none"> 1. Ensure voltage across terminals 1 and 3 of connector 6PL is between 90 and 264 VAC. 2. Voltage across terminals 1 and 6 of plug 6PL of power supply 2PS should be 24VDC. If not, replace power supply 2PS.
Motor Rotating And No kV Output At Spray Gun, LED1 On	<ol style="list-style-type: none"> 1. Defective control wires in cable or switch in gun 2. Defective relay board 	<ol style="list-style-type: none"> 1. Check for continuity from 4PL-3 of relay board to gun handle when switch at gun is ON. If no continuity, replace high voltage cable or gun ON/OFF switch. 2. If #1 above checks ok, replace relay board.
Motor Not Rotating But kV Output Ok, LED2 Off	<ol style="list-style-type: none"> 1. Defective relay board fuse F4 	<ol style="list-style-type: none"> 1. Replace defective fuse.
Motor Not Rotating But kV Output Ok, LED2 On	<ol style="list-style-type: none"> 1. Defective control wires in high voltage cable 	<ol style="list-style-type: none"> 1. Replace high voltage cable.
Motor Rotating Too Fast	<ol style="list-style-type: none"> 1. Defective power supply 2PS 	<ol style="list-style-type: none"> 1. Voltage across terminals 1 and 6 of plug 6PL of power supply 2PS should be 24VDC. If not, replace power supply 2PS.
Excessive Current Draw	<ol style="list-style-type: none"> 1. Short in cable or gun 2. Defective main PC board 3. Defective high voltage multiplier 	<ol style="list-style-type: none"> 1. Remove cable from power supply. If problem goes away, check gun or cable for cause. 2. Test PC board with LTST5000 Tester. Replace PC board if improper results are obtained. 3. If 1 and 2 above are okay, replace high voltage multiplier.
Excessive Shocking	<ol style="list-style-type: none"> 1. Discontinuity in ground circuit 	<ol style="list-style-type: none"> 1. Perform the Ground Test Procedure as describe in the "Maintenance" section of this manual.

SERVICE LEVEL

Personnel who service this unit must be qualified electronics technicians. Replacement parts are designed to be made at the assembly level. See “Parts Identification” section of this manual for part numbers and ordering information.



WARNING

► **ALWAYS** turn power to the power supply **OFF**, unplug the electrical cord from its outlet, remove the front panel fuse, and lock the power supply out before making repairs or replacements.



CAUTION

► **DO NOT** attempt to make repairs to the printed circuit board!

► **DO NOT** attempt to make repairs beyond those described. All others should be made **ONLY** by Ransburg service personnel.

REPLACEMENT PROCEDURES

Before making replacements, check for defective wiring or connections between the affected components. If there is a broken wire, defective insulation, or dirty, loose or corroded connections, repair or replace them before going to the expense of replacing a component.

Fuses 1FU & 2FU

1. Insert screwdriver into slot into the respective fuse holder, push in, and rotate counter-clockwise.
2. Remove screwdriver and fuse holder will slide out.
3. Remove fuse from fuse holder and

replace with new fuse (See “Parts Identification” section of this manual for part numbers).

NOTE

► Two (2) spare fuses, included from the factory, are located on the inside of the top lid of the cabinet.

4. Insert fuse holder back into front panel and with a slight inward pressure, rotate screwdriver clockwise until it locks into place.
5. Secure cabinet lid and plug power supply back in.

ON/OFF Switch 1SW

1. Ensure power supply is unplugged from AC outlet and open cabinet lid.



WARNING

► **ALWAYS** double check that the power supply is unplugged from its AC outlet before working with any internal wiring.

2. Remove the four quick connect terminals from the rear of ON/OFF switch 1SW.

NOTE

► It is recommended that the four ON/OFF switch wires be tagged with their respective terminal connections to 1SW before removing.

3. Press panel retaining clips on top and bottom of switch 1SW together and push switch out of panel from the inside.
4. Press new switch (See “Parts Identification” section of this manual for part numbers) into panel opening with terminals 1A and 2A to the bottom of the cabinet.
5. Reconnect the four quick connect terminals to the new switch as follows:

From	To
1LF-RED or BLACK	1SW-1
1LF-BLUE	1SW-2
2TB-3	1SW-1A
2TB-4	1SW-2A

- Secure cabinet door and plug power supply back in.

High Voltage Multiplier

- Remove HV cable from power supply.
- Ensure power supply is unplugged from AC outlet and open cabinet lid.
- Unplug connector 3PL from the top of the high voltage multiplier oscillator.
- Unscrew (4) screws from oscillator board and remove high voltage multiplier plug.
- Unscrew (4) screws from relay board mounted to top of cascade aluminum housing.
- Unscrew (4) screws from top play of power supply 2PS and remove cover plate.
- Disconnect connection 5PL and 6PL from power supply 2PS.
- Unscrew (4) standoffs holding power supply 2PS to side of cascade aluminum housing and remove power supply.
- Remove the screws that mount the high voltage multipliers' aluminum housing to the bottom panel.
- Remove the high voltage multiplier assembly out from the power supply.
- Remove the (3) screws that secure the aluminum housing to the high voltage multiplier.
- Install the aluminum housing on the new

high voltage multiplier (See "Parts Identification" section of this manual for part numbers). Ensure connector faces the front of the housing before installing.

- Install the high voltage multiplier assembly in the power supply by securing the (6) mounting screws to the back panel.
- Plug oscillator board back into cascade plug. Screw oscillator board to cascade with (4) screws.
- Attach connector 3PL back into the high voltage multiplier oscillator.
- Mount power supply 2PS to side of the cascade aluminum housing using the (4) standoffs.
- Connect 5PL and 6PL connectors back to power supply 2PS.
- Attach cover plate for 2PS with (4) retaining screws.
- Attach relay board to top of cascade aluminum housing using the (4) retaining screws.
- Secure the cabinet lid and plug the power supply back in.
- Reinstall HV cable.

Main PC Board

- Ensure power supply is unplugged from AC outlet and open cabinet lid.
- Disconnect plugs/connectors J7, J3, J2, and J1 from main PC board. (see Figure 9).
- Remove (3) screws from heat sink base and lift the PC board out.
- Insert new PC Board (See "Parts Identification" section of this manual for part numbers) and secure the (3) heat sink screws.
- Reconnect plugs J7, J3, J2, and J1.

6. Secure the cabinet lid and plug the power supply back in.

Relay Board

1. Ensure power supply is unplugged from AC outlet and open cabinet lid.



WARNING

► **ALWAYS** double check that the power supply is unplugged from its AC outlet before removing the cover plate from power supply 1SUP.

2. Unscrew and Remove all wires from the currently installed relay board.
3. Remove the screws that mount the relay board to the top of the cascade.
4. Install relay board, tighten retaining screws (4) to mount relay board on top of the cascade.
5. Connect the ground lead from ground screw shown in Figure 7 to the relay board terminal block position 4PL-7.
6. Connect the trigger lead wire from the PC Mainboard J3-5 connector to relay board terminal block position 4PL-6.
7. Connect the +V (blue lead) from plug 5PL on the power supply 2PS to the relay board terminal block position 4PL-5.
8. Connect the orange lead from the high voltage connector (1CON) to the relay board terminal block position 4PL-2.
9. Connect the blue lead from the high voltage connector (1CON) to the relay board terminal block position 4PL-3.
10. Secure the cabinet door, replace the fuses, and reconnect the AC source.

Power Supply 1PS

1. Ensure power supply is unplugged from AC outlet and open cabinet lid.
2. Remove the (4) screw from the 1PS cover plate and remove the plate.
3. Remove connectors 1PL and 2PL from power supply 1PS.
4. Remove the (4) cover plate standoffs from power supply 1PS and remove the power supply from the unit.
5. Install new 1SUP power supply (See “Parts Identification” section of this manual for part numbers) using the (4) cover plate standoffs. Ensure larger terminal strip (2PL) of power supply 1PS faces the front of unit as shown in Figure 9.
6. Connect connectors 1PL and 2PL to new power supply and reinstall cover plate.
7. Secure cabinet door and plug power supply back in.

Power Supply 2PS

1. Remove HV cable from power supply.
2. Ensure power supply is unplugged from AC outlet and open cabinet lid
3. Remove the (4) screw from the 2PS cover plate and remove the plate.
4. Remove connectors 5PL and 6PL from power supply 2PS.
5. Remove the (4) cover plate standoffs that mount power supply 2PS to the high voltage multipliers’ aluminum housing.
6. Remove power supply 2PS from the unit.
7. Install the new 24 VDC supply 2PS (See “Parts Identification” section of this manual for part numbers). Ensure the

smaller 3 pin connector is facing the left side of the unit when installing.

8. Secure power supply 2PS to the aluminum housing using the (4) cover plate standoffs.
9. Plug connectors 5PL and 6PL back into power supply 2PS.
10. Attach the cover plate to the standoffs using the (4) screws.
11. Secure the cabinet lid, plug the power supply back in and reinstall the HV cable.

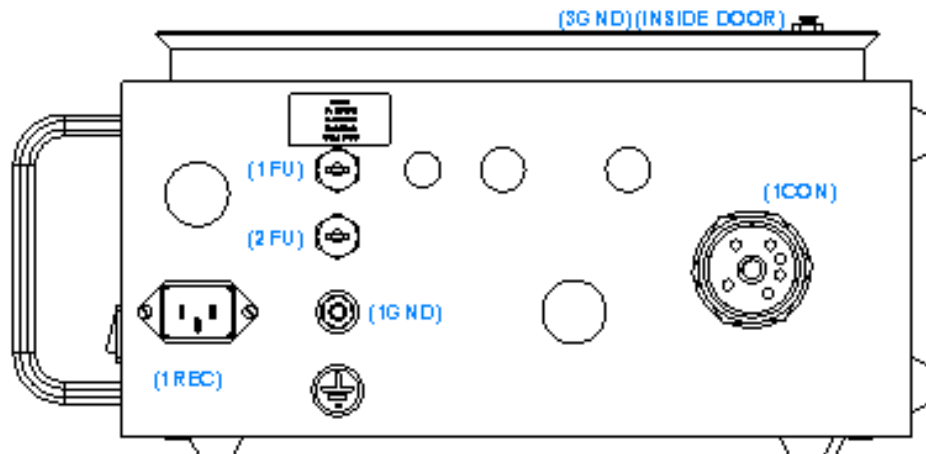
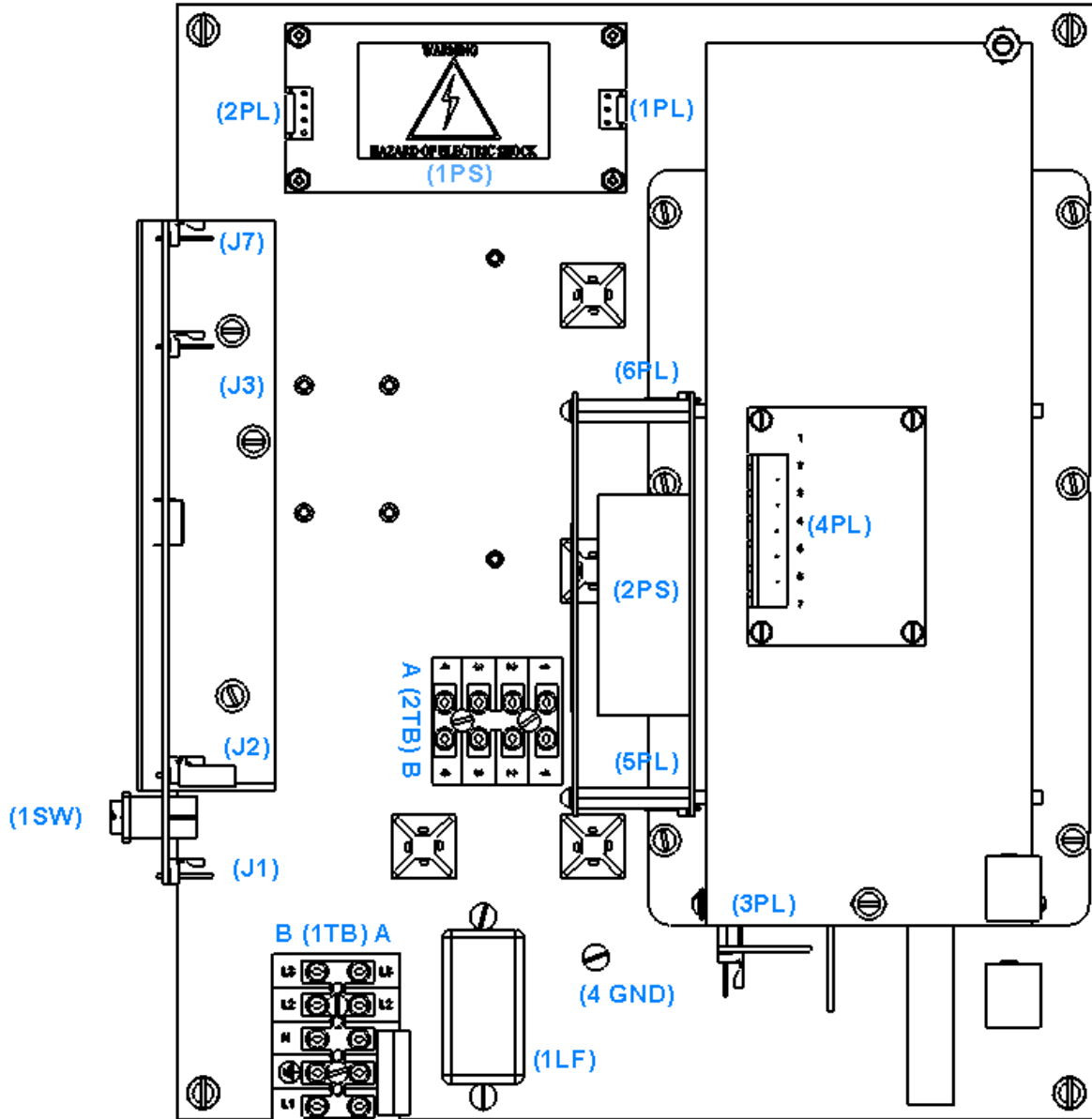

Figure 17: 9060 (80102-21X) Internal Component Locations

N O T E S

PARTS IDENTIFICATION

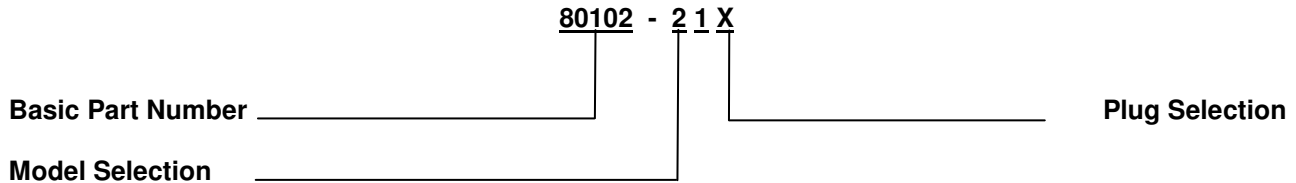

9060 HIGH VOLTAGE CONTROLLER MODEL IDENTIFICATION *

When ordering, use 80102-A1B as indicated by Table A and B. Three digits must follow the basic part number, for example:



* Model number and serial number of the voltage controller is located on the left outside face of the main enclosure.

Table A - Model Selection	
Dash No.	Description
2	No. 2 Process Gun - Electric Motor

Table B - Plug Selection	
Dash No.	Description
1	Domestic 
2	European 
3	China 

9060 High Voltage Controller - Parts List	
Part #	Description
72771-06	Fuse (250V, 1A, 5mm x 20mm)
76434-01	Switch, Rocker (On-Off Switch)
80116-28	9060 High Voltage Controller PC Mainboard
76649-00	Board, Motor Control (Relay Board)
75337-04	Power Supply, Switching (24VDC Motor Power Supply 2PS)
79428-00	Power Supply, 24V (24VDC Power Supply 1PS)
19370-XX	Cable Assembly, Superflex, (XX denotes cable length)
79350-03	9060 High Voltage Cascade Sub Assembly

NOTES

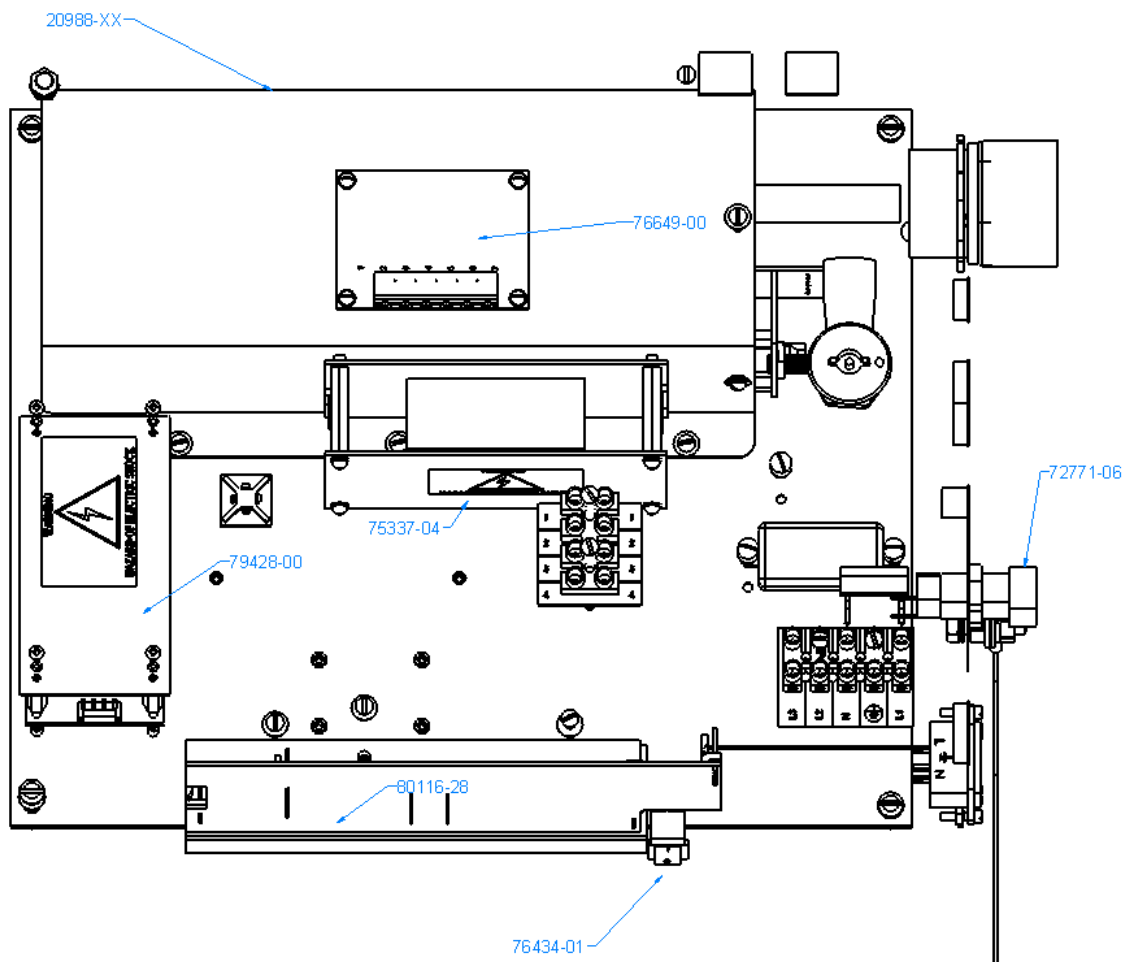

Figure 18: Parts Identifications

ACCESSORIES

9060 High Voltage Controller - Accessories List	
Part #	Description
76652-01	HV Probe
76652-02	Meter w/Test Leads
76652-03	Paint Test Probe w/Meter
76652-04	Deluxe Kit (Include HV Probe, Meter w/Test Leads, and Paint Test Probe)
70863-00	Dielectric Grease

WARRANTY POLICIES

LIMITED WARRANTY

Ransburg will replace or repair without charge any part and/or equipment that falls within the specified time (see below) because of faulty workmanship or material, provided that the equipment has been used and maintained in accordance with Ransburg's written safety and operating instructions, and has been used under normal operating conditions. Normal wear items are excluded.

THE USE OF OTHER THAN RANSBURG APPROVED PARTS, VOID ALL WARRANTIES.

SPARE PARTS: One hundred and eighty (180) days from date of purchase, except for rebuilt parts (any part number ending in "R") for which the warranty period is ninety (90) days.

EQUIPMENT: When purchased as a complete unit, (i.e., guns, power supplies, control units, etc.), is one (1) year from date of purchase.

WRAPPING THE APPLICATOR, ASSOCIATED VALVES AND TUBING, AND SUPPORTING HARDWARE IN PLASTIC, SHRINK-WRAP, OR ANY OTHER NON-APPROVED COVERING, WILL VOID THIS WARRANTY.

RANSBURG'S ONLY OBLIGATION UNDER THIS WARRANTY IS TO REPLACE PARTS THAT HAVE FAILED BECAUSE OF FAULTY WORKMANSHIP OR MATERIALS. THERE ARE NO IMPLIED WARRANTIES NOR WARRANTIES OF EITHER MERCHANTABILITY OR FITNESS FOR A PARTICULAR PURPOSE. RANSBURG ASSUMES NO LIABILITY FOR INJURY, DAMAGE TO PROPERTY OR FOR CONSEQUENTIAL DAMAGES FOR LOSS OF GOODWILL OR PRODUCTION OR INCOME, WHICH RESULT FROM USE OR MISUSE OF THE EQUIPMENT BY PURCHASER OR OTHERS.

EXCLUSIONS:

If, in Ransburg's opinion the warranty item in question, or other items damaged by this part was improperly installed, operated or maintained, Ransburg will assume no responsibility for repair or replacement of the item or items. The purchaser, therefore will assume all responsibility for any cost of repair or replacement and service related costs if applicable.

Manufacturing

1910 North Wayne Street
Angola, Indiana 46703-9100
Telephone: 260-665-8800
Fax: 260-665-8516

Technical Service—Assistance

320 Philips Ave.
Toledo, Ohio 43612-1493
Telephone (toll free): 800-233-3366
Fax: 419-470-2233

Technical Support Representative will direct you to the appropriate telephone number for ordering Spare Parts.