

Propeller Technical Manual	Jabiru Aircraft Pty Ltd 
JPM0001-3	4A482U0D And 4A484E0D Propellers

Propeller Technical Manual

FOR

4A482U0D and 4A484E0D Propellers

DOCUMENT No. JPM0001-3

DATED: 9th April 2014



This Manual has been prepared as a guide to correctly operate & maintain Jabiru 4A482U0D and 4A484E0D propellers.

It is the owner's responsibility to regularly check the Jabiru web site at www.jabiru.net.au for applicable Service Bulletins and have them implemented as soon as possible. Manuals are also updated periodically with the latest revisions available from the web site. Failure to maintain the propeller, engine or aircraft with current service information may render the aircraft un-airworthy and void Jabiru's Limited, Express Warranty.

This document is controlled while it remains on the Jabiru server. Once this no longer applies the document becomes uncontrolled.

Should you have any questions or doubts about the contents of this manual, please contact Jabiru Aircraft Pty Ltd.

This document is controlled while it remains on the Jabiru server. Once this no longer applies the document becomes uncontrolled.										
ISSUE	1	2	3					Dated : 9th April 2014	Issued By: DPS	Page: 1 of 34
L:\files\Manuals_For_Products\Propeller_Manuals\JPM0001-3.docx										



1.1 TABLE OF FIGURES..... 3

1.2 LIST OF TABLES 3

2 GENERAL INFORMATION..... 4

2.1 FOREWORD..... 4

2.2 MANUFACTURER DETAILS 4

2.3 WARNINGS 5

2.4 LIST OF EFFECTIVE PAGES..... 6

2.5 APPLICABILITY..... 6

 2.5.1 Models 6

2.6 READING THIS MANUAL..... 6

2.7 DEGREE OF DIFFICULTY..... 7

2.8 DESCRIPTION & SPECIFICATIONS..... 8

 2.8.1 Description 8

 2.8.2 4A482U0D Propeller Specifications 9

 2.8.3 4A484E0D Propeller Specifications 9

2.9 APPROVED PROPELLER & ENGINE COMBINATIONS 10

2.10 LIFE 10

3 PROPELLER OPERATION 11

3.1 OPERATING LIMITATIONS..... 11

 3.1.1 Maximum RPM..... 11

 3.1.2 Pitch 11

3.2 PROPELLER TUNING – JABIRU AIRFRAMES 12

3.3 PROPELLER TUNING – NON-JABIRU AIRFRAMES..... 12

 3.3.1 Propeller Design..... 12

 3.3.2 Airframe Drag and Power Settings 13

3.4 NORMAL OPERATIONS:..... 14

 3.4.1 Ground Handling..... 14

 3.4.2 Hand Manoeuvring..... 14

 3.4.3 Parking..... 14

 3.4.4 Daily Inspection 14

3.5 ABNORMAL OPERATIONS: 15

 3.5.1 Running In Rain..... 15

4 PROPELLER MAINTENANCE 16

4.1 INTRODUCTION..... 16

 4.1.1 Torque Specifications 16

 4.1.2 Pitch Setting Specifications 16

 4.1.3 Propeller Markings 16

4.2 MAINTAINER REQUIREMENTS 16

4.3 TOOL & GAUGE CONTROL..... 17

4.4 TOOLS & EQUIPMENT:..... 17

4.5 CLEANING, GROUND HANDLING & STORAGE 17

 4.5.1 Cleaning..... 17

 4.5.2 Ground Handling 17

 4.5.3 Parking..... 18

 4.5.4 Off-Aircraft Storage..... 18

 4.5.5 Returning Propeller to Service 18

4.6 MAINTENANCE SCHEDULE..... 18

 4.6.1 Service Interval Tolerance 19

 4.6.2 5-Hour Inspection..... 20

 4.6.3 100-Hourly Inspection..... 20

 4.6.4 Annual Inspection..... 21

 4.6.5 500-Hour Inspection 21

4.7 MAINTENANCE PROCEDURES..... 22

 4.7.1 Acceptance Checking..... 22

 4.7.2 Procedure – Removal of Existing Propeller 22

 4.7.3 Procedure - Propeller Assembly 22

 4.7.4 Bench-Mount Pitch Setting 24

 4.7.5 Procedure - Propeller installation..... 25

This document is controlled while it remains on the Jabiru server. Once this no longer applies the document becomes uncontrolled.

4.7.6	<i>Procedure – Propeller Tracking</i>	27
4.7.7	<i>Procedure – Spinner Tracking</i>	27
4.7.8	<i>Procedure – Propeller Balance (Maintenance)</i>	27
4.8	TRUBLESHOOTING	28
4.8.1	<i>Defect Recognition</i>	28
5	PROPELLER OVERHAUL	29
5.1	OVERHAULER REQUIREMENTS	29
5.2	TOOL & GAUGE CONTROL	29
5.3	TOOLS & EQUIPMENT:	29
5.3.1	<i>Propeller Balancing</i>	29
5.4	OVERHAUL SEQUENCE	30
5.5	PROPELLER REMOVED INSPECTIONS	30
5.6	REPAIR METHODS	31
5.6.1	<i>Propeller Balancing Procedure (Overhaul)</i>	31
5.6.2	<i>Damage Limits & Repairs</i>	31
5.6.3	<i>General</i>	31
6	REPORTING	32
6.1.1	<i>Continued Operational Safety Reporting</i>	32
6.1.2	<i>Owner Change of Address Notice</i>	32
7	APPENDIX A – WORKSHEETS	33

1.1 Table of Figures

Figure 1 – 4A482U0D Propeller Assembly (Spinner Not Shown)	8
Figure 2 – 4A484E0D Propeller Assembly (Spinner Not Shown)	8
Figure 3 – Airframe Drag Curves	13
Figure 4 – Blade Assy Detail (View from beside hub, front hub not shown)	23
Figure 5 – Hub Gap (View from beside hub)	23
Figure 6 – Pitch Set Jig	25
Figure 7 – Typical Propeller Installation	26
Figure 8 – Propeller Hub Assembly (Spinner and blades not shown)	26
Figure 9 – Propeller Balancing	30

1.2 List of Tables

Table 1 – 4A482U0D Propeller Specifications	9
Table 2 – 4A484E0D Propeller Specifications	9
Table 3 – Factory-Built Models	11
Table 4 – Kit-Built Models	11
Table 5 – Torque Specifications	16
Table 6 – Inspection Chart	19

Propeller Technical Manual	Jabiru Aircraft Pty Ltd 
JPM0001-3	4A482U0D And 4A484E0D Propellers

2 General Information

2.1 Foreword

It is the owner's responsibility to become fully aware of the particular maintenance requirements and limitations applicable to the propellers when used in their application.

The information in this manual is based upon data available at the time of publication, and is supplemented and kept current by Airworthiness Publications such as Service Bulletins & Service Letters released by JABIRU AIRCRAFT Pty Ltd. These are distributed directly to owners in addition to being posted on the JABIRU website or provided to your local Dealer or Distributor so that they have the latest authorised recommendations for servicing the propellers. New owners of pre-owned propellers should ensure that the transfer of ownership has been advised to JABIRU AIRCRAFT Pty Ltd or your local dealer or distributor. Existing owners should ensure that their contact details on file with JABIRU AIRCRAFT Pty Ltd remain current.

IMPORTANT

All maintenance should be undertaken with careful regard for the procedures outlined in this manual. A detailed record of maintenance undertaken should be recorded in the Aircraft Log Books.

Eligible JABIRU Propellers operating in the Light Sport Aircraft category must be maintained by an Authorised Person (LAME for CASA-registered aircraft, Owner or Level 2 Holder for RA-Aus-registered aircraft). In all cases, NO MODIFICATIONS ARE PERMITTED without approval from the propeller manufacturer. It is the owner's responsibility to ensure that their propeller is maintained by an appropriate person.

In the interests of product development, we encourage owners to make suggestions related to design improvements. However, the final decision on their adoption or otherwise rests with JABIRU AIRCRAFT Pty Ltd.

2.2 Manufacturer Details

Jabiru Aircraft P/L
 PO Box 5792
 Bundaberg West,
 QLD 4670
 Phone: 07 4155 1778
 Fax: 07 4155 2669
 Email: info@jabiru.net.au

Street Address:

Jabiru Aircraft
 Airport Drive, Hinkler Airport
 Bundaberg
 QLD 4670

This document is controlled while it remains on the Jabiru server. Once this no longer applies the document becomes uncontrolled.										
ISSUE	1	2	3					Dated : 9th April 2014	Issued By: DPS	Page: 4 of 34

Propeller Technical Manual	Jabiru Aircraft Pty Ltd 
JPM0001-3	4A482U0D And 4A484E0D Propellers

2.3 Warnings

WARNING

DO NOT GO NEAR THE PROPELLER IF THERE IS A PERSON IN OR NEAR THE COCKPIT.

ENSURE AIRCRAFT MASTER SWITCH IS "OFF" BEFORE COMMENCING ANY WORK ON PROPELLER.

DO NOT RUN ENGINE WITH PROPELLER DISCONNECTED OR ENGINE DAMAGE WILL RESULT.

THE PROPELLERS IN THIS MANUAL ARE DESIGNED AND TESTED FOR JABIRU ENGINES ONLY.

Jabiru Aircraft Pty Ltd has devoted significant resources and testing to develop Jabiru aircraft propellers for recreational flying and flight training. Any other uses or applications not approved by Jabiru Aircraft P/L may be extremely hazardous, leading to property damage, or injury or death of persons on or in the vicinity of the vehicle. Jabiru Aircraft Pty Ltd does not support the use of this propeller in any applications which do not meet the requirements of the appropriate Pilot Operating Handbook or Flight Manual. Any non-compliant operation may render the propeller & aircraft un-airworthy and will void any warranty issued by Jabiru.

Jabiru Propellers are designed to be maintained only in strict accordance with this Technical Manual. Any variation of any kind, including alteration to any component at all, whether replacement, relocation, modification or otherwise which is not strictly in accordance with these manuals may lead to dramatic changes in the performance of the aircraft and may cause unexpected engine stoppage, loss of control or have other detrimental effects on the aircraft which may lead to injury or death. Jabiru Aircraft Pty Ltd does not support any modifications to the propeller, its parts, or components. Any such actions may render the propeller & aircraft un-airworthy and will void any warranty issued by Jabiru.

Maintenance and modification cannot be supervised by the manufacturer. Maintenance requires extreme cleanliness, exact parts, precise workmanship and proper consumables. It is your responsibility to ensure absolute attention to detail no matter who may become involved in work on this propeller. Your safety, your life and your passenger's lives rely on precise and accurate following of instructions in this manual.

In exchange for the technical manual provided by Jabiru Aircraft Pty. Ltd. ("Jabiru") I hereby agree to waive, release, and hold Jabiru harmless from any injury, loss, damage, or mishap that I, my spouse, heirs, or next of kin may suffer as a result of my use of any Jabiru product, except to the extent due to gross negligence or willful misconduct by Jabiru. I understand that proper skills and training are essential to minimize the unavoidable risks of property damage, serious bodily injury and death that arise from the use of Jabiru products.

IMPORTANT

**Always think before acting. Use common sense.
WORKING WITH PROPELLERS CAN BE EXTREMELY DANGEROUS.**

This document is controlled while it remains on the Jabiru server. Once this no longer applies the document becomes uncontrolled.										
ISSUE	1	2	3					Dated : 9th April 2014	Issued By: DPS	Page: 5 of 34

2.4 List of Effective Pages

This manual is revised as a whole. All pages retain the revision status of the overall document. Altered technical content is shown in red.

Issue Notes

1	Original Issue
2	Pitch settings for factory built models altered
3	ASTM 2483-12 task format added, Detailed worksheet added

2.5 Applicability

2.5.1 Models

This manual contains JABIRU recommended procedures and instructions for ground handling, servicing and maintaining the following Jabiru propeller models:

4A482U0D	-	2200 Scimitar Propeller Assy – Ground Adjustable, 2 Blade Composite.
4A484E0D	-	3300 Scimitar Propeller Assy – Ground Adjustable, 2 Blade Composite.





These propellers are not type certified, though certain serial numbers claim compliance with the requirements of ASTM F2506-10 for operations in Light Sport Aircraft (LSA) category aircraft. The propellers listed are approved by JABIRU for use on Jabiru 2200 and Jabiru 3300 Aircraft Engines respectively. The propellers are not approved for use on other engine types or models.

2.6 Reading This Manual

- If you are reading this manual on a computer and want to be able to quickly zoom in and out: Hold down the Ctrl key while rotating the wheel button on your mouse. In most programs this will instantly zoom in or out.
- To do the same thing on a modern laptop either plug in a wheel mouse as detailed above or use the built-in track-pad. Put two fingers on the pad close together then move them apart diagonally. To reverse, put two fingers on the pad at opposite diagonal points on the pad and bring them together diagonally. This works on most modern PC-laptops.
- This document has been created with hyperlinks between referenced items. So, when reading the manual on a computer you can click on the page number of an item on the table of contents and the computer will skip to that page. Also, if a paragraph says “refer to Section 4.5.4” – then you can click on the “4.5.4” and automatically skip to that page. Similarly, if Figures or Tables are referenced.
- To open a search window press “Ctrl-f”. Depending on the program, this will normally open a small search window where you can enter keywords. For example, searching for the word “life” will allow you to quickly find all reference to life maintenance items.

2.7 Degree Of Difficulty

- In this manual we have used a “spanner scale” to help technicians approach a job. Anyone considering undertaking a task in this manual must realistically assess themselves against this scale and not attempt any task for which they lack knowledge or the required tools.
- This manual is intended for use by experienced technicians. While all processes will be explained as clearly as possible, some knowledge is assumed. This manual is not intended to be sufficient reference for a person with no other training to safely complete inspections & maintenance. Knowledge of standard aircraft practices (such as are detailed in FAA AC43) is assumed.

The Spanner Scale	Translation
	Simple, basic, straightforward. A careful layman, with guidance, can achieve this.
	Straightforward, but with some technical bits. Basic knowledge, care and guidance needed.
	Straightforward, but requires special tools, training and/or judgement. Sound basic knowledge guidance and a careful approach are required.
	A technical job. Take your time, double-check everything. Only for the experienced overhauler.
	A difficult job. Requires special tools, solid skills, good judgement. Only for experts.

2.8 Description & Specifications

2.8.1 Description

- The Jabiru Propellers detailed in this manual are 2-bladed Scimitar ground adjustable designs. The blades are constructed of fibreglass composite while the hub is forged from Aluminium.
- A Urethane protective coating is applied to the leading edge of both blades.
- The propeller finish is black Gel-coat, though other colours may be used for some applications.
- All propellers discussed within this manual are for **TRACTOR** applications only.

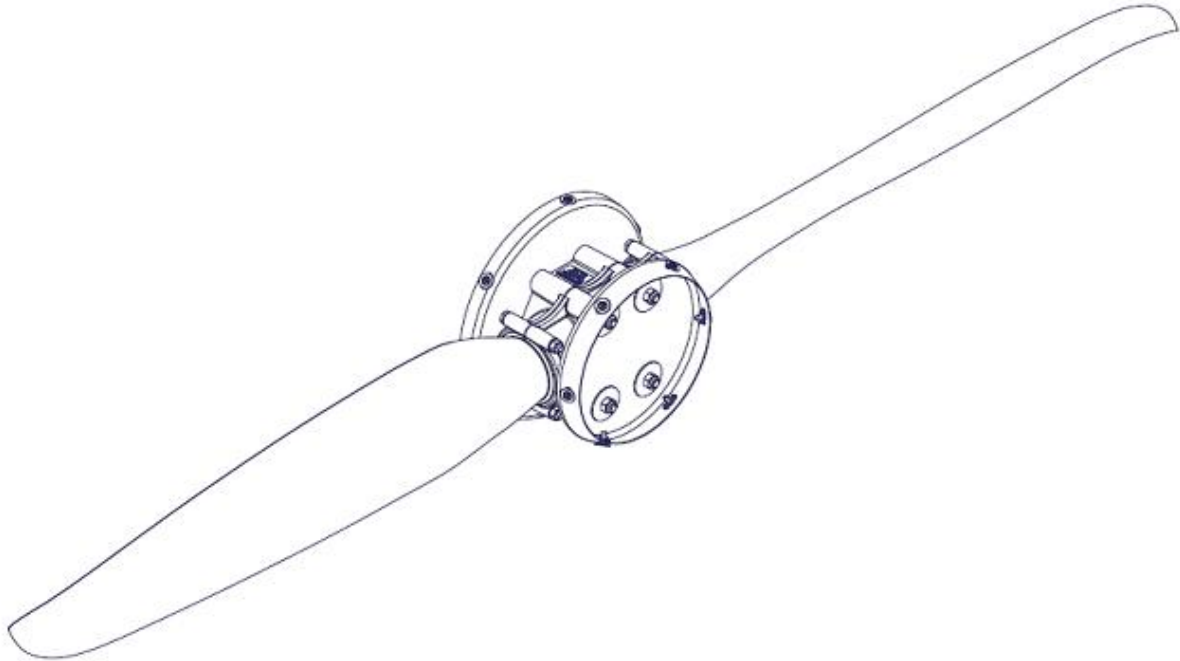

Figure 1 – 4A482U0D Propeller Assembly (Spinner Not Shown)

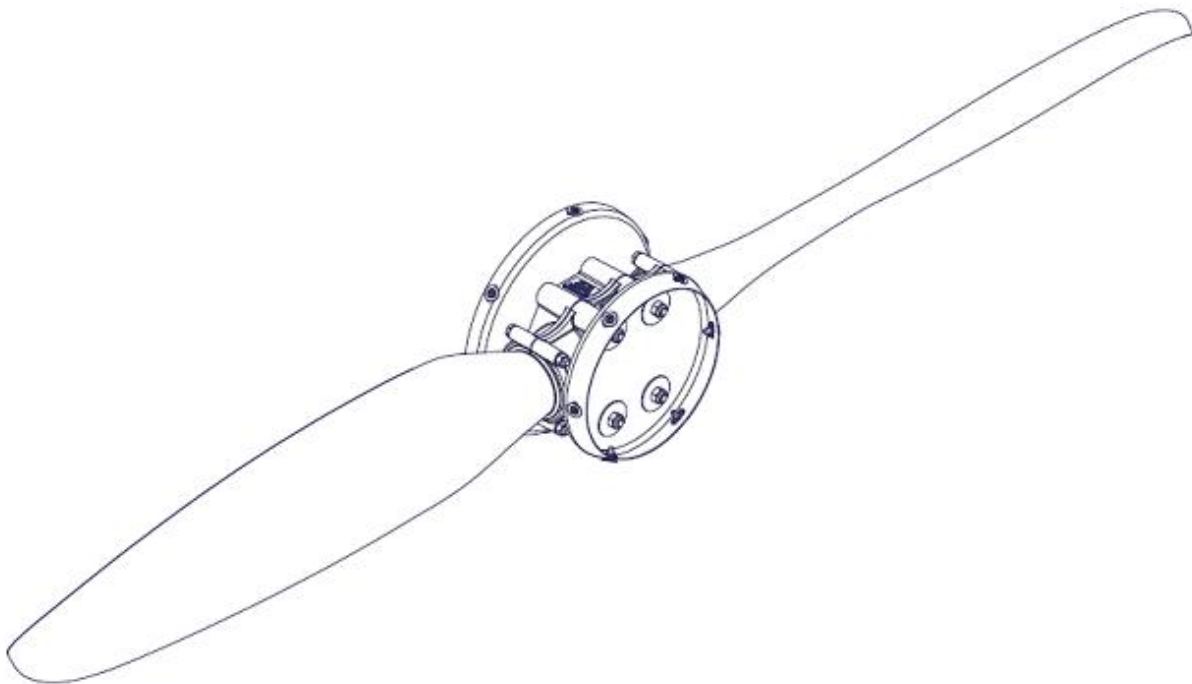

Figure 2 – 4A484E0D Propeller Assembly (Spinner Not Shown)

2.8.2 4A482U0D Propeller Specifications

- Note that approved propeller and engine combinations are detailed in Section 2.9

Table 1 – 4A482U0D Propeller Specifications

Propeller Model	4A482U0D			
Engine	Jabiru 2200 Variants			
Max Power	85hp			
Propeller Flange	Std – 4662084 2" Ext – 466218N			
Dia	1524 Dia (60")			
Pitch¹	889 – 1118mm (35" - 48") All angle readings taken at a position 508mm from rotation axis.			
	Pitch	Equiv. Angle	Pitch	Equiv. Angle
	889mm (35")	15.6°	1067mm (42")	18.5°
	914mm (36")	16.0°	1092mm (43")	18.9°
	940mm (37")	16.4°	1118mm (44")	19.3°
	965mm (38")	16.8°	1143mm (45")	19.7°
	991mm (39")	17.2°	1168mm (46")	20.1°
	1016mm (40")	17.7°	1194mm (47")	20.5°
1041mm (41")	18.1°	1219mm (48")	20.9°	
Pitch Tolerance	Both blades to be within $\pm 0.25^\circ$ of designated setting Blades to match within $\pm 0.1^\circ$			
Remarks/Limits	Not above 3300 RPM			
Mass Moment of Inertia	0.20kgm ² (nominal)			

2.8.3 4A484E0D Propeller Specifications

- Note that approved propeller and engine combinations are detailed in Section 2.9

Table 2 – 4A484E0D Propeller Specifications

Propeller Model	4A484E0D			
Engine	Jabiru 3300 Variants			
Max Power	125hp			
Propeller Flange	Std – 4662084 2" Ext – 466218N			
Dia	1524 Dia (60")			
Pitch²	889 – 1118mm (45" - 58") All angle readings taken at a position 508mm from rotation axis.			
	Pitch	Equiv. Angle	Pitch	Equiv. Angle
	1143mm (45")	19.7°	1321mm (52")	22.5°
	1168mm (46")	20.1°	1346mm (53")	22.9°
	1194mm (47")	20.5°	1372mm (54")	23.3°
	1219mm (48")	20.9°	1397mm (55")	23.6°
	1245mm (49")	21.3°	1422mm (56")	24.0°
	1270mm (50")	21.7°	1448mm (57")	24.4°
1295mm (51")	22.1°	1473mm (58")	24.8°	
Pitch Tolerance	Both blades to be within $\pm 0.25^\circ$ of designated setting Blades to match within $\pm 0.1^\circ$			
Remarks/Limits	Not above 3300 RPM			
Mass Moment of Inertia	0.27kgm ² (nominal)			

¹ Pitch adjustable by operator

² Pitch adjustable by operator

Propeller Technical Manual	Jabiru Aircraft Pty Ltd 
JPM0001-3	4A482U0D And 4A484E0D Propellers

2.9 Approved Propeller & Engine Combinations

- 4A482U0D propellers are approved for use on all variants of the Jabiru 2200 Aircraft Engine only.
- 4A484E0D propellers are approved for use on all variants of the Jabiru 3300 Aircraft Engine only.
- All propellers discussed within this manual are for **TRACTOR** applications only.

2.10 Life

- The propeller has a designed time between overhaul of 1,000 hours. Refer to Section 5 for overhaul details.
- Propeller components (except hardware) are assessed on condition. There are no items with a fixed life.

3 Propeller Operation

3.1 Operating Limitations

3.1.1 Maximum RPM

- All propellers covered by this manual are limited to 3300 RPM.

3.1.2 Pitch

- The 4A482U0D and 4A484E0D propellers are ground-adjustable in pitch.
- Pitch information for various airframe and engine combinations are given in the propeller type data sheet and are repeated here for information.
- Pitch limits are listed below for factory-built models. These are manufacturer specifications and must be adhered to for these models.
- Pitch recommendations for various kit-built airframe and engine combinations are listed below. It is strongly recommended that operators use these recommendations for their aircraft.

Table 3 – Factory-Built Models

Propeller	Airframe	Engine	Propeller Flange	Dia x Pitch Specification	Limits
4A482U0D	Jabiru J120-C	Jabiru 2200	4662084 Family	1524 x 965 (60" x 38")	Not Above 3300 RPM
4A482U0D	Jabiru J160-D	Jabiru 2200	4662084 Family	1524 x 965 (60" x 38")	Not Above 3300 RPM
4A482U0D	Jabiru J170-C	Jabiru 2200	4662084 Family	1524 x 965 (60" x 38")	Not Above 3300 RPM
4A482U0D	Jabiru J170-D	Jabiru 2200	4662084 Family	1524 x 965 (60" x 38")	Not Above 3300 RPM
4A484E0D	Jabiru J230-C	Jabiru 3300	4662084 Family	1524 x 1321 (60" x 52")	Not Above 3300 RPM
4A484E0D	Jabiru J230-D	Jabiru 3300	4662084 Family	1524 x 1321 (60" x 52")	Not Above 3300 RPM

Table 4 – Kit-Built Models

Propeller	Airframe	Engine	Propeller Flange	Dia x Pitch Recommendation	Limits
4A482U0D	Jabiru UL ³ Family	Jabiru 2200	4662084 Family	1524 x 965 (60" x 38")	Not Above 3300 RPM
4A484E0D	Jabiru UL Family	Jabiru 3300	4662084 Family	1524 x 1321 (60" x 52")	Not Above 3300 RPM
4A482U0D	Jabiru SP Family	Jabiru 2200	4662084 Family	1524 x 965 (60" x 38")	Not Above 3300 RPM
4A484E0D	Jabiru SP Family	Jabiru 3300	4662084 Family	1524 x 1321 (60" x 52")	Not Above 3300 RPM
4A482U0D	Jabiru J120 Family	Jabiru 2200	4662084 Family	1524 x 965 (60" x 38")	Not Above 3300 RPM
4A482U0D	Jabiru J160 Family	Jabiru 2200	4662084 Family	1524 x 965 (60" x 38")	Not Above 3300 RPM
4A482U0D	Jabiru J170 Family	Jabiru 2200	4662084 Family	1524 x 965 (60" x 38")	Not Above 3300 RPM
4A484E0D	Jabiru J230 & J430 Family	Jabiru 3300	4662084 Family	1524 x 1321 (60" x 52")	Not Above 3300 RPM
4A484E0D	Jabiru J200 & J400 Family	Jabiru 3300	4662084 Family	1524 x 1321 (60" x 52")	Not Above 3300 RPM
4A484E0D	Jabiru J250 & J450 Family	Jabiru 3300	4662084 Family	1524 x 1321 (60" x 52")	Not Above 3300 RPM

³ The UL family is known as the "Calypso" in some markets

Propeller Technical Manual	Jabiru Aircraft Pty Ltd 
JPM0001-3	4A482U0D And 4A484E0D Propellers

3.2 Propeller Tuning – Jabiru Airframes

- Propeller pitch information is given in Table 3 and Table 4 for Jabiru Aircraft models.
- The propeller must be installed as detailed in Section 4.7.3.
- Note the inspection requirements of Section 4.6: inspections are required after installation & initial running.

3.3 Propeller Tuning – Non-Jabiru Airframes

- The following information has been included to assist operators in setting up their 4A482U0D propeller for their non-Jabiru airframe.
- The propeller must be installed as detailed in Section 4.7.3.
- Note the inspection requirements of Section 4.6: initial inspections are required after installation and initial running.

WARNING

**CORRECT PROPELLER ADJUSTMENT IS VITAL FOR THE LIFE OF THE ENGINE
OPERATION WITH INCORRECT PROPELLER ADJUSTMENT MAY RESULT IN ENGINE DAMAGE.**

- Operators must ensure that the propeller is adjusted to a pitch setting which matches the power output of the engine. This can be achieved by balancing the following considerations:
 - The propeller should be adjusted so that the engine will achieve 3200 – 3300 RPM in full power straight and level flight at sea level.
 - Propellers fitted to 2200 engines should achieve 2800 – 3000 RPM at the aircraft’s best climb speed.
 - Propellers fitted to 3300 engines should achieve 2800 – 3000 RPM at the aircraft’s best climb speed.
 - The 2200 engine should use 14 – 17 Litres of fuel per hour at cruise power.
 - The 3300 engine should use 23 – 26 Litres of fuel per hour at cruise power.
 - Cruise should be carried out at around 22 inhg manifold pressure (at Sea Level).
 - EGT and CHT must remain within the limits given in the Engine Maintenance Manual (or the Pilot’s Operating Handbook or Flight Manual for the aircraft.).
- Extensive testing has shown that these parameters will provide the best balance of performance.
- When compared with wooden propellers used on the Jabiru engine, the 4A482U0D propeller must be set to a significantly lower pitch setting for equivalent performance: For example, when fitted to a Jabiru J120 airframe the 4A482U0D propeller set at 38” pitch will provide cruise speeds slightly faster than a 42” pitch wooden propeller. This is due to the increased blade stiffness of the composite propeller.
- The 4A484E0D propeller is set to the same pitch as the wooden propeller or slightly lower for equivalent performance: For example, when fitted to a Jabiru J430 airframe the 4A484E0D propeller set at 53” pitch will provide cruise speeds comparable to Jabiru 53” or 55” wooden propellers.
- In general, both propellers perform best with pitch set slightly low or “fine”. Testing with Jabiru J120 aircraft showed that the propeller produced similar cruise speeds for a range of pitches between 40” and 36”. While the cruise speeds for the lower pitch settings were similar, engine temperatures and fuel consumption were improved.
- Set at 38” the 4A482U0D propeller showed the following when compared to being set at 42”;
- Cruise speed reduced by approximately 2 KIAS.
- Engine temperatures reduced
- Oil consumption reduced
- Compression leakdown results improved
- Fuel consumption reduced
- Take-off and climb performance improved
- EGT: Temperature difference between hottest and coldest readings reduced. Peak temperatures reduced.

3.3.1 Propeller Design

- The 4A482U0D propeller has been designed for an ideal condition where the aircraft moves forward at 100 Knots when the engine is operating at 2800 RPM.
- The 4A484E0D propeller has been designed for an ideal condition where the aircraft moves forward at 120 Knots when the engine is operating at 2800 RPM.
- While the propeller will still work effectively at other speed and RPM combinations efficiency will drop slightly and extra care must be taken to ensure the other installation factors are met.

This document is controlled while it remains on the Jabiru server. Once this no longer applies the document becomes uncontrolled.										
ISSUE	1	2	3					Dated : 9th April 2014	Issued By: DPS	Page: 12 of 34

3.3.2 Airframe Drag and Power Settings

- The following section is included to help operators understand the behaviour of their aircraft and propeller.

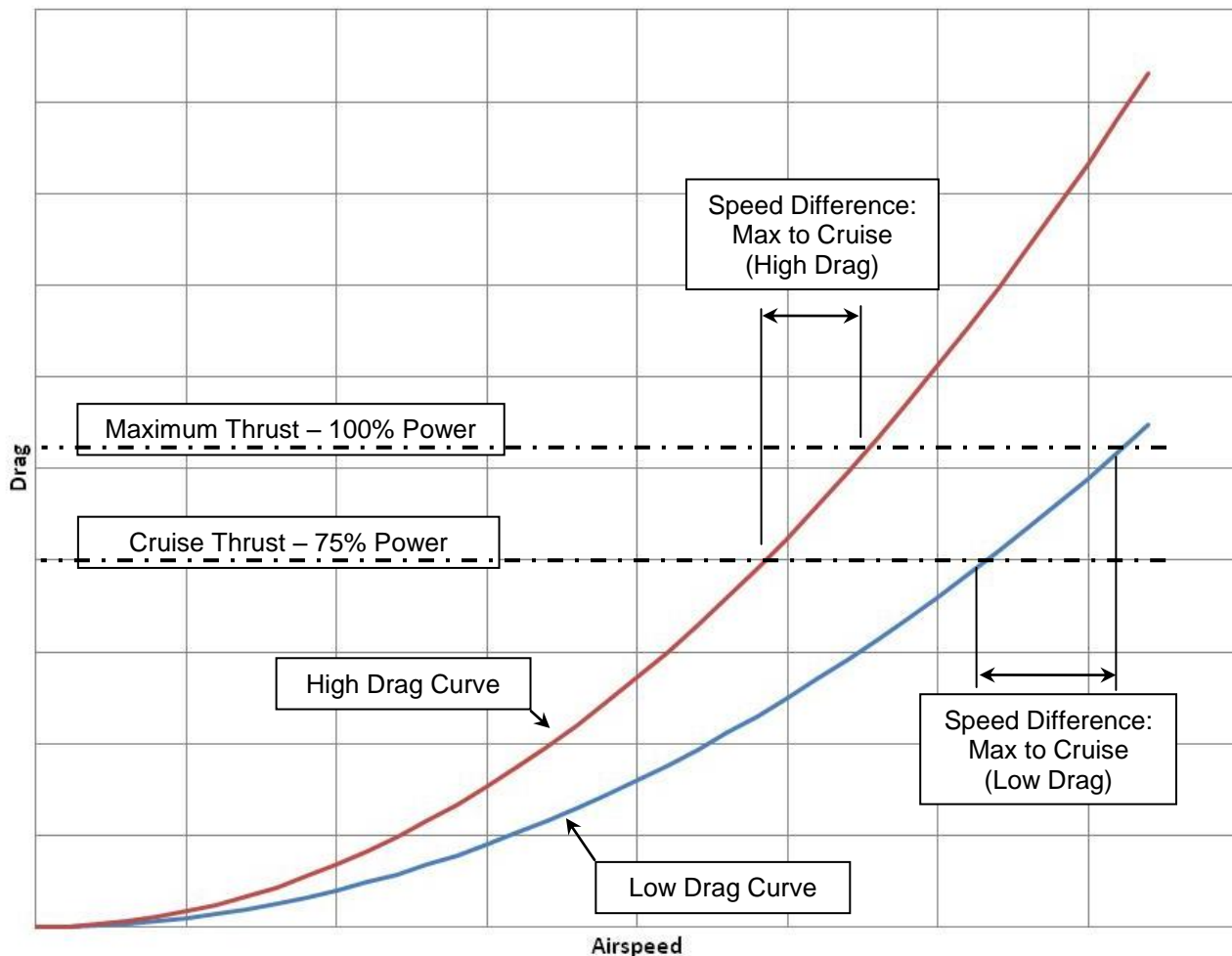



Figure 3 – Airframe Drag Curves

- Figure 3 is a simple representation of a “high drag” aircraft compared with a “low drag” type – showing how drag increases with airspeed.
- Two horizontal lines are shown on the chart: a maximum thrust line and a cruise thrust line. In this simple model it is assumed that the thrust is the same for both airframes and the thrust is directly related to engine power output.
- It can be seen that in terms of the difference in speeds, reducing thrust has much more effect on a low-drag airframe. A streamlined aircraft may have a cruise speed 20 – 30 knots or more below its maximum while a high-drag aircraft might cruise only 5 or 10 knots below its maximum. Both would be using the same cruise thrust setting.
- Assume that both aircraft are set up correctly with the propeller producing 3,250RPM in level flight at full power at sea level. A low drag airframe might have to reduce engine RPM to 2,800 to reach cruise thrust while a high drag aircraft could operate at 3,000 RPM and still be producing the same cruise thrust. Again this is because the thrust (and power) required drops away so much more quickly for the high-drag type as speed decreases.
- An important factor is that RPM is not always a direct indicator of the engine's current power output: picture a car driving along a flat road or climbing a hill: in both cases the RPM can be the same while the power output varies greatly. So depending on what the aircraft is doing, an engine turning at 2,800 RPM could be producing 10% or 95% power or any value between.
- Ultimately best practice is to fit a manifold pressure gauge, calibrate it to the aircraft and use that to ensure that cruise power settings are within acceptable limits.
- Fuel flow and EGT can also be good indicators of power setting.

Propeller Technical Manual	Jabiru Aircraft Pty Ltd 
JPM0001-3	4A482U0D And 4A484E0D Propellers

3.4 Normal Operations:

3.4.1 Ground Handling

- Impact from gravel, grass, insects and other objects can damage the propeller. When operating from gravel runways the pilot should be aware of this at all times and plan their operations to suit.
 - Take care when carrying out ground tests of the engine – either make sure the propeller is not over any loose gravel or perform run-ups while rolling forwards at normal taxi speed (note that this procedure requires some practice and is not recommended for student pilots).
 - Unless required due to short runway length, do not hold the aircraft on the brakes while increasing power at the start of the takeoff roll.
 - Take care when taxiing through ditches or over rough or uneven ground. Reduce speed, pass over the ditch diagonally and do not abruptly increase power to climb out the far side. If unsure, stop the engine and push the aircraft across the ditch by hand.

3.4.2 Hand Manoeuvring

- The aircraft may be moved by hand using the propeller as a handle. However, the following procedures must be used:

IMPORTANT

Always think before acting and use common sense.

Working with propellers can be extremely dangerous.

Ensure that the aircraft's master switch is OFF before walking near the propeller

Do not go near the propeller if there is a person in or near the cockpit.

WARNING

PROPELLER WILL BECOME HOT IN DIRECT SUNLIGHT.

- Only one person at a time may hold the propeller.
- Always hold the propeller as close as possible to the root – in practice this normally means placing hands immediately beside the spinner.
- Orient the propeller horizontally unless manoeuvring the aircraft past an obstruction which would hit the propeller if it were left horizontal. Do not park the propeller in a vertical orientation (see notes below – Section 3.4.3)

3.4.3 Parking

- To prevent the accumulation of moisture in the lower blade, the propeller must always be left in the horizontal position when the engine is being parked for any length of time, especially in conditions of high ambient humidity.
- For maximum life it is recommended that propeller blade covers be fitted if the aircraft is to be parked outside. This is to protect the propeller from UV and other damage. Propeller covers must be white or a light colour shade to minimise the temperature the blades are exposed to. Covers must also be appropriately vented to prevent the accumulation of moisture inside the cover which can cause corrosion and blade discolouration.

3.4.4 Daily Inspection

- Inspect both blades for:
 - Urethane condition: peeling, tears, pitting or abrasion.
 - Fibreglass condition: stone chips, trailing edge chips, de-laminations, whitening.
 - Resin condition: cracks.

Propeller Technical Manual	Jabiru Aircraft Pty Ltd 
JPM0001-3	4A482U0D And 4A484E0D Propellers

3.5 Abnormal Operations:

3.5.1 Running In Rain

- Jabiru Aircraft do not recommend or endorse operating in rain.
- The following is intended as a guide for owners who have, for whatever reason, been forced to fly through rain.
 - Do not operate in heavy rain or hail.
 - Know your limitations and the limitations of your aircraft. If in doubt, divert or land.
 - Maintain situational awareness – do not fly into rising terrain or near high obstacles (radio towers etc) in low visibility conditions.
 - If forced to fly through rain reduce engine RPM. 2600rpm or less is recommended – though the pilot must maintain a safe airspeed.
 - Monitor propeller condition – on landing check the blades for damage. Minor damage can be repaired in the field in accordance with the details given in Section 5.6.2. Do not fly on with damage beyond the limits set in Section 5.6.2.
 - A Urethane leading edge is provided for impact protection and also allows the propeller to be run in rain if required. However, the propeller is not intended for extended operation in heavy rain. Running in heavy rain will erode the Urethane in time – reducing the efficiency of the propeller blade and upsetting its balance.
 - After extended running in rain the Urethane may become so badly worn that the composite leading edge underneath is exposed. Once exposed, the fibreglass will quickly be damaged by continued operation in rain. It is possible that a propeller which has been damaged to this extent may suffer fibreglass de-lamination from a blade – massively reducing propeller efficiency and increasing vibration to the point where the engine must be shut down. This makes continued operation with exposed fibreglass edges extremely hazardous.

4 Propeller Maintenance

4.1 Introduction

- The following chapter details the maintenance requirements of the Jabiru 4A482U0D and 4A484E0D propellers.

WARNING

ENSURE IGNITION SYSTEM IS "OFF" BEFORE COMMENCING ANY WORK ON PROPELLER.

DO NOT RUN ENGINE WITH PROPELLER DISCONNECTED OR ENGINE DAMAGE WILL RESULT.

4.1.1 Torque Specifications

Table 5 – Torque Specifications

Part	Hardware	Torque: nm	Torque ft.lbs
Outer Blade Clamp Bolts: ¼" UNF thread	AN4	11	(8)
Propeller Mounting Bolts: 5/16" UNF thread	AN5	16	(12)
Propeller Flange Screws: 3/8" UNF thread Refer to Engine Maintenance Manual for details.	Unbrako 1960 or Brighton Best 1960 Grade UNF Cap Screws	40	(30)

4.1.2 Pitch Setting Specifications

- The following apply when setting the propeller blade pitch in accordance with Section 4.7.4
- Gap between blade and pitch plate: 0.60 - 0.90mm (0.024" - 0.035")
- Maximum difference between gap at front and rear of each blade: 0.05mm (0.002")

4.1.3 Propeller Markings

- Each propeller is marked with its model number and serial number via a label on the rear hub.
- Each major component of the propeller – blades, front and rear hub – are similarly identified by labels detailing the part number and serial number of the items.

IMPORTANT

Labels are required for warranty and airworthiness monitoring. If a label is damage or degraded contact Jabiru Aircraft for a replacement.

4.2 Maintainer Requirements

- The following are recommended as the minimum requirements for someone carrying out maintenance & inspection on Jabiru Propellers:

1. Facilities

- Enclosed workspace with sealed floor, lighting, compressed air & mains electricity.

2. Training

- Completion of an approved instruction course specific to Jabiru Aircraft. Approved courses include those offered by Jabiru Aircraft Australia or by local Jabiru Aircraft representatives.

3. Rating

- Commercial maintainers must hold ratings required by their local Airworthiness Authority.

4. Experience

- A minimum of 2 years experience working on aircraft under supervision is recommended for commercial maintainers before working un-supervised.

Propeller Technical Manual	Jabiru Aircraft Pty Ltd 
JPM0001-3	4A482U0D And 4A484E0D Propellers

4.3 Tool & Gauge Control

- Tool & gauge control is an important part of aviation maintenance systems. Tools & gauges must be accurate enough for the intended use (i.e. a 12" steel ruler is not the appropriate tool to use to measure the thickness of the middle of the propeller blade) & be accurately calibrated by an approved laboratory.
- Calibrations must be kept up to date. This means a check calibration every year or more frequently for regularly used, critical tooling.
- Even quality equipment will wear over time so items like reams and go / no-go gauges must periodically be checked to ensure they remain within limits.

4.4 Tools & Equipment:

- Access to the following tools will be required. All tools must be good quality items:
 - Ring/open end spanner set (Imperial): 7/16" & 1/2" sizes.
 - Ratchet 3/8" drive, 2" extension bar, socket set (imperial): 7/16" & 1/2" sizes.
 - Screwdrivers: flat blade and Phillips head in various sizes
 - Torque wrench: 3/8" drive, "name" brand (Snap-On, Warren & Brown etc), recently calibrated. The wrench must have a suitable scale for use at the values given in Table 5.
- Access to the following equipment will be required:
 - Calipers
 - Accurate level / protractor – Digital or Vernier type "bubble" level.
 - Propeller balance jig
 - Propeller tracking rig
 - Rags, soft mallet, hammers
 - TorqueSeal brand security marking lacquer or similar, such as coloured nail varnish

4.5 Cleaning, Ground Handling & Storage

4.5.1 Cleaning

- Keeping the propeller clean is important. Besides maintaining the appearance of the aircraft, cleaning makes inspection and maintenance easier.
- Generally, the exterior surfaces can be kept bright by washing with water and a mild soap or detergent, followed by a rinse with water and drying with a cloth or a chamois.
- Remove stubborn oil and grease with a cloth moistened with mineral turpentine, then wash with water and a mild soap, rinse and dry as stated before.
- Water spots or oxidation may occur on the blade. These spots can be removed using a mild polish or specialist water spot remover, however operators must ensure that the polish is suitable for use on epoxy resin composites and that it does not contain silicon. Always follow the instructions of the manufacturer of the polish.

WARNING

Silicon based cleaning compounds and certain wax polishes are absorbed into the composite materials. Discolouration may occur and reparability will be affected. Such compounds must not be used.

4.5.2 Ground Handling

- All Jabiru aircraft are relatively light and should always be moved by hand.
- The aircraft may be moved by placing the propeller in the horizontal and then placing one hand on the propeller on either side of the spinner. The aircraft can then be pulled forward.

WARNING

Never move the aircraft in this manner whilst the engine is hot as it may fire when the propeller is moved and result in severe injury.

**Always ensure that the Master and Ignitions are OFF.
Never approach the propeller when anyone is in the aircraft.
Always treat the propeller as LIVE! IT KILLS!**

This document is controlled while it remains on the Jabiru server. Once this no longer applies the document becomes uncontrolled.										
ISSUE	1	2	3					Dated : 9th April 2014	Issued By: DPS	Page: 17 of 34

Propeller Technical Manual	Jabiru Aircraft Pty Ltd 
JPM0001-3	4A482U0D And 4A484E0D Propellers

WARNING
PROPELLER WILL BECOME HOT IN DIRECT SUNLIGHT.

4.5.3 Parking

- It is strongly recommended that aircraft are stored in hangars wherever possible to minimise degradation caused by the elements and pests.
- When parking the aircraft always orient the propeller with the blades horizontal to prevent gravity-fed moisture migration to the lower blade.
- The propeller is designed to be UV resistant, however damage such as fading will gradually occur when the propeller is regularly exposed to sunlight. The propeller should be covered if the aircraft is to be stored outside or in a location exposed to sunlight.
- Propeller blade covers must be white or a similar light shade to minimise heat build up.
- Covers must also be appropriately vented to prevent the accumulation of moisture inside the cover which can cause corrosion and blade discolouration.

4.5.4 Off-Aircraft Storage

- The propeller must always be stored horizontally to minimise uneven moisture accumulation in the blades, causing imbalance.
- Where possible the propeller should be stored at above 0°C (freezing).
- Propellers may be stored horizontally on any flat, dry shelf or surface. Propellers should be positioned so that they are resting on the drive face.
- Ensure no items are resting or leaning against the propeller.
- Ensure the propeller is not subjected to direct sunlight.
- Minimise the propeller’s exposure to humidity while in storage
- As much as possible minimise the propeller’s exposure to changes in temperature & humidity.
- If the propeller is stored in packaging or under a cover adequate ventilation must be provided to prevent condensation forming – condensation can cause corrosion and blade discolouration over time.

4.5.5 Returning Propeller to Service

- When a propeller is returned to service after extended storage the following must be checked:
 - Propeller balance
 - Fit of drive bushes into propeller hub: must be a close fit with no free-play.
 - Condition of the blades: fibreglass blade, leading edge protection & leading edge tape (where equipped).
 - Depending on the current service life of the propeller it may be prudent to carry out the 500-hour checks detailed in Table 6 before fitting the propeller to an aircraft.

4.6 Maintenance Schedule

- Note that while the spinner assembly is not considered a part of the propeller proper, some spinner inspections are included below for reference.
- The chart below shows the recommended intervals at which items are to be inspected.
- Additional detail of the maintenance required in each section is given below the inspection chart.
- As shown in the chart, there are items to be inspected each **5 Hours**, **100 hours**, **Annually** and at **500 hours**.
- The **5 hour** inspection is carried out whenever the propeller mounting bolts have been adjusted during maintenance – for example 5 hours after the propeller is installed or 5 hours after the hub bolts were loosened to allow blade pitch adjustment. This is to ensure that the bolt tension is checked after the hub assembly has “settled”. This inspection must be carried out between 4 and 6 hours after the mounting bolts have been adjusted.
- When conducting an inspection at 100 hours, all items marked under **Each 100 Hours** is inspected, serviced or otherwise completed.
- An inspection conducted annually includes the 100 hour items in addition to the items marked under **Annual Inspection**.
- The **500-hour** inspection is based on propeller time in service only.



4.6.1 Service Interval Tolerance

- A tolerance of plus or minus 3 hours is allowable on all service intervals set within this manual unless stated otherwise.

Table 6 – Inspection Chart

		Each 500 Hours	Annual Inspection	Each 100 Hours	5 Hours After Hub Bolt Adjustment
SPINNER					
1	General condition – cracks etc.	*	*	*	*
2	Screw holes are not excessively elongated	*	*	*	*
SPINNER FLANGE					
3	General condition – cracks around perimeter of hub etc	*	*	*	*
4	Anchor nuts & rivets secure	*	*	*	*
5	Visual inspection for signs of fretting / looseness	*	*	*	*
SPINNER SCREWS					
6	Head & thread condition	*	*	*	*
7	Tightness of screw in nut. Replace anchor nuts if loose.	*	*	*	*
PROPELLER					
8	Urethane condition	*	*	*	*
9	Blade condition	*	*	*	*
10	Hub condition	*	*	*	*
11	Propeller Drive Bush Fit			*	*
12	Blade Pitch Check (Un-pinned Blades Only)				*
13	Propeller Blade Stem Inspection				*
14	Hub Dye Penetrant Inspection				*
PROPELLER BOLTS / NUTS					
15	Condition – corrosion etc.	*	*	*	*

		Each 500 Hours			
		Annual Inspection			
		Each 100 Hours			
		5 Hours After Hub Bolt Adjustment			
16	Bolt / Nut tension	*	*	*	*
TRACKING					
17	Propeller tracking		*	*	*
18	Spinner tracking		*	*	*
BALANCE					
19	Check Propeller Balance			*	*
PROPELLER FLANGE - CRANKSHAFT SCREWS					
20	Check Tension per Table 5				*

4.6.2 5-Hour Inspection

- As all possible circumstances cannot be listed here, the following is provided as guidance only. A critical, trained eye is required and inspections should include, but not be limited to, the following.
- Remove the spinner and carry out a thorough visual inspection checking for cracking, fraying, corrosion and other damage.
- Check for loose, missing, corroded or damaged fasteners and hardware.
- Check for deposits and radial markings which indicate fretting between moving parts.
- Visually check the condition of the propeller, looking for damage to the leading edge protection, glass delamination and cracks.
- Check the tension of the propeller bolts/nuts – Tension if required.
- Re-assemble

4.6.3 100-Hourly Inspection

- As all possible circumstances cannot be listed here, the following is provided as guidance only. A critical, trained eye is required and inspections should include, but not be limited to, the following.
- Remove the spinner and carry out a thorough visual inspection checking for cracking, fraying, corrosion and other damage.
- Check for loose, missing, corroded or damaged fasteners and hardware.
- Check for deposits and radial markings which indicate fretting between moving parts.
- Visually check the condition of the propeller, looking for damage to the leading edge protection, glass delamination and cracks.
- Check the tension of the propeller bolts/nuts – Tension per Table 5 if required.
- Re-assemble
- Check spinner and Prop Tracking.

Propeller Technical Manual	Jabiru Aircraft Pty Ltd 
JPM0001-3	4A482U0D And 4A484E0D Propellers

4.6.4 Annual Inspection

- **Annual inspections include all the items listed for the 100-hourly inspection above plus the additional items below.**
- As all possible circumstances cannot be listed here, the following is provided as guidance only. A critical, trained eye is required and inspections should include, but not be limited to, the following.
- Remove the propeller from the aircraft.
- Thoroughly check the propeller for cracking, wear or damage – particularly in those areas not visible while the propeller is mounted to the engine.
- Inspect the blade stems for cracking, abrasion or deposits.
- Test the fit of the propeller drive bushes as detailed in Section 5.5
- Check the propeller balance as detailed in Section 4.7.6
- Re-fit the propeller to the aircraft.
- Check spinner and Prop Tracking.

4.6.5 500-Hour Inspection

- 500-hour inspections are based on time in service only. They include the items listed for the annual inspection above plus the additional items below.
- As all possible circumstances cannot be listed here, the following is provided as guidance only. A critical, trained eye is required and inspections should include, but not be limited to, the following.
- Remove the propeller from the aircraft.
- Disassemble the blades from the hub.
- Thoroughly check the propeller for cracking, wear or damage – particularly in those areas not visible while the propeller is mounted to the engine.
- Inspect the blade stems for cracking, abrasion or deposits. Where equipped, inspect the condition of the blade pitch locking pins.
- Carry out a Dye Penetrant inspection of the front and rear hubs. If cracking or defects are identified provide clear photographs to Jabiru Aircraft Pty Ltd for assessment.
- Visually inspect and apply a test torque to the screws which hold the propeller flange to the front of the crankshaft. Refer to the Engine Maintenance Manual and follow its procedures for this test.
- Assemble propeller and set blade pitch.
- Re-fit the propeller to the aircraft.
- Check spinner and Prop Tracking.

4.7 Maintenance Procedures

4.7.1 Acceptance Checking

- Propellers supplied are balanced before shipping. Balancing before fitting to an aircraft is not necessary.
- Visually inspect propeller to ensure that it has not been damaged in transit.
- Check that the propeller drive bushes are a neat fit in the sockets of the propeller. Section 5.5 gives details.

4.7.2 Procedure – Removal of Existing Propeller



Type of Maintenance:	Line Maintenance
Level of Certification:	Owner with Task Specific Training

Figure 7 shows a typical propeller installation.

1. Remove Machine Screws and Tinnerman Washers from Spinner.
2. Remove Spinner.
3. Unbolt Propeller Bolts - 4 off.
4. Remove Bolts, Spinner Flanges, Washers and Propeller.

4.7.3 Procedure - Propeller Assembly



Type of Maintenance:	Heavy Maintenance
Level of Certification:	LSA Repairman (Inspection or Maintenance), with task specific Training

1. Place the rear hub plate on a flat bench.
2. Fit the two blades to the hub. By design there is a small space between the inner ends of the two blades (Figure 4). Care must be taken to ensure that the blades are positioned with their retaining shoulders hard against the matching shoulders of the hub (i.e. with the gap between blades as large as possible). Failure to achieve this can result in one blade being positioned differently to the other, resulting in an out of balance condition and increased vibration.
3. Place the front hub plate on the assembly, taking care to align it with the pitch lock pins in the blades (where equipped).
4. Loosely fit the 4 outer blade clamp bolts to the hub assembly.
5. Gradually tighten the 4 clamp bolts to the value given in Table 5. This is to “settle” the blades into the hub.
6. Ensure that the gap between the front and rear hubs is even on both sides (Figure 5).
7. Loosen the clamp screws.
8. For propellers without pitch lock pins, use a static jig to set the blade angles.

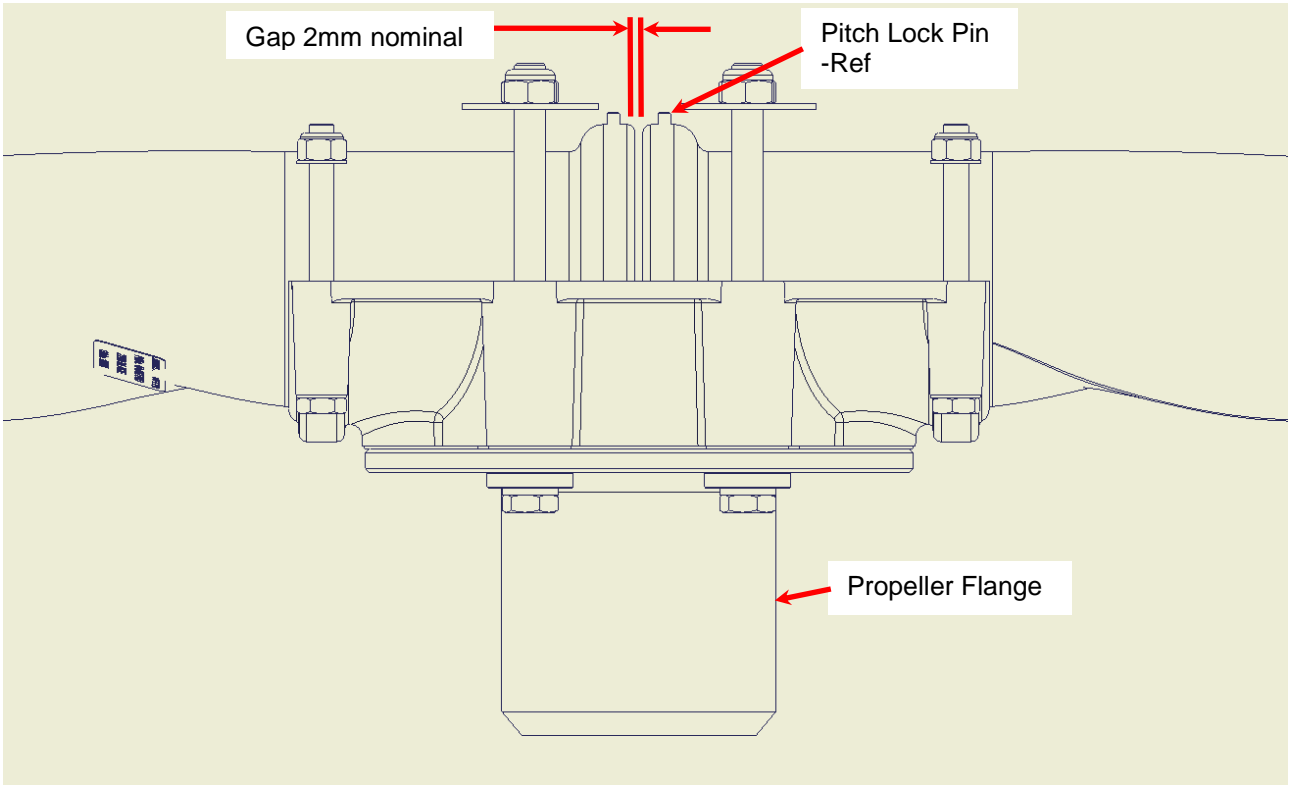

Figure 4 – Blade Assy Detail (View from beside hub, front hub not shown)

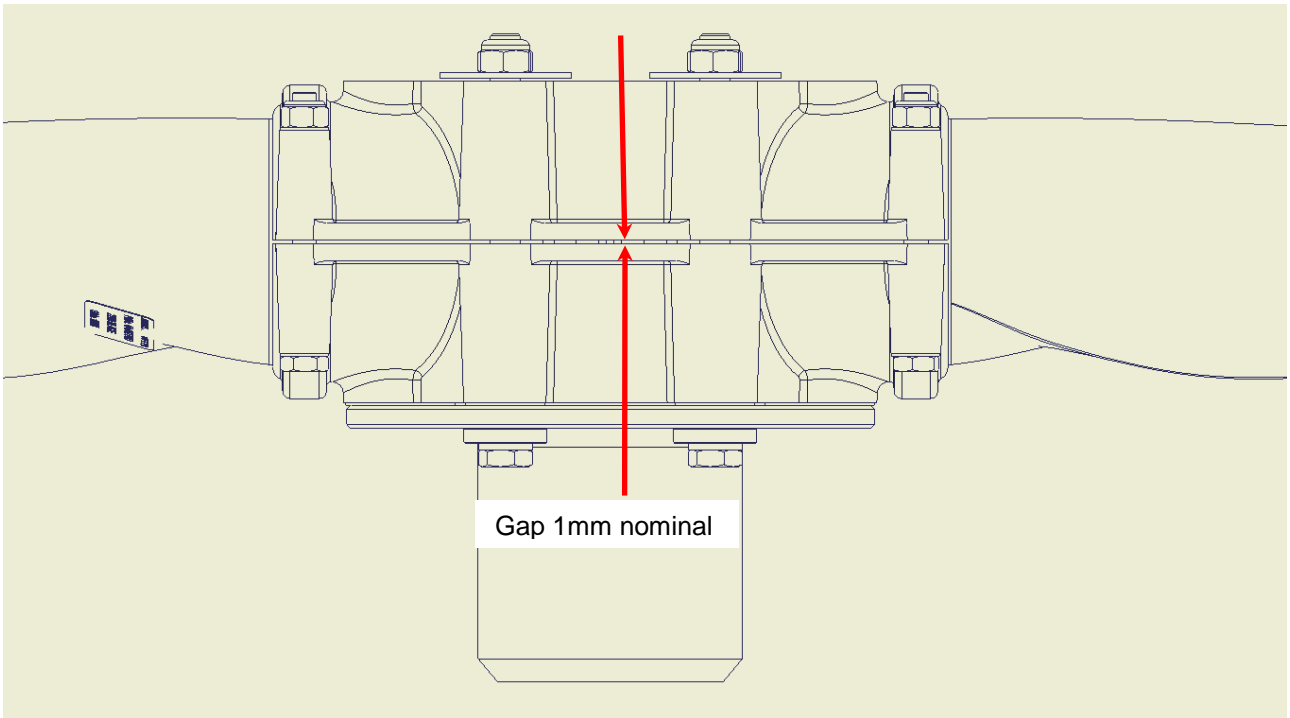

Figure 5 – Hub Gap (View from beside hub)

4.7.4 Bench-Mount Pitch Setting



Type of Maintenance:	Heavy Maintenance
Level of Certification:	LSA Repairman (Inspection or Maintenance), with task specific Training

The following procedure is the recommended method used to set the blade pitch of propellers not equipped with pitch lock pins. The setting Jig is shown in Figure 6.

1. Place the pitch setting jig on a flat, level surface. A special bench such as that shown in Figure 6 allows the assembly to sit level and the operator to adjust the 5/16" bolts without lifting it.
2. Fit the pitch setting plates to either end of the jig.
3. Using an accurate protractor, measure the angles of the pitch setting plates relative to the central propeller mounting face. Ensure that both pitch set plates are at the same angle to the mounting face: a difference here may indicate damage to the jig.
4. Assemble the hub halves and the blades, fitting only the outer 1/4" bolts and tightening them evenly until the nuts just touch the hub halves.
5. Place the propeller on the rig, taking care not to damage the blades against the pitch set plates. Pieces of thin cardboard or rubber may be placed on the pitch plates to protect the blades.
6. Use the propeller drive pins to locate the propeller on the jig.
7. Fit the four 5/16" bolts through the propeller pins and the propeller & tighten until the nuts touch the hub.
8. Remove any packing from between the blades and the pitch set plates. Use a 0.75mm (0.030") steel feeler gauge to check the gap between the pitch plate and the blades: this gap must be constant from one end of the pitch set plate to the other.
9. Once the blade positions are set, tighten both the 1/4" and 5/16" bolts to 5lb.ft.
10. Re-check the blades against the pitch set plates. It may be necessary to loosen the bolts and adjust the blade position.
11. Acceptable limits for blade pitch are given in Section 4.1.2.
12. Set the 1/4" clamping bolts to the torque specified in Section 4.1.1.
13. Remove the 5/16" bolts holding the propeller to the jig & remove the propeller.

WARNING

PROPELLER PITCH SETTING IS CRUCIAL FOR THE PERFORMANCE AND LONGEVITY OF THE AIRCRAFT AND ENGINE.

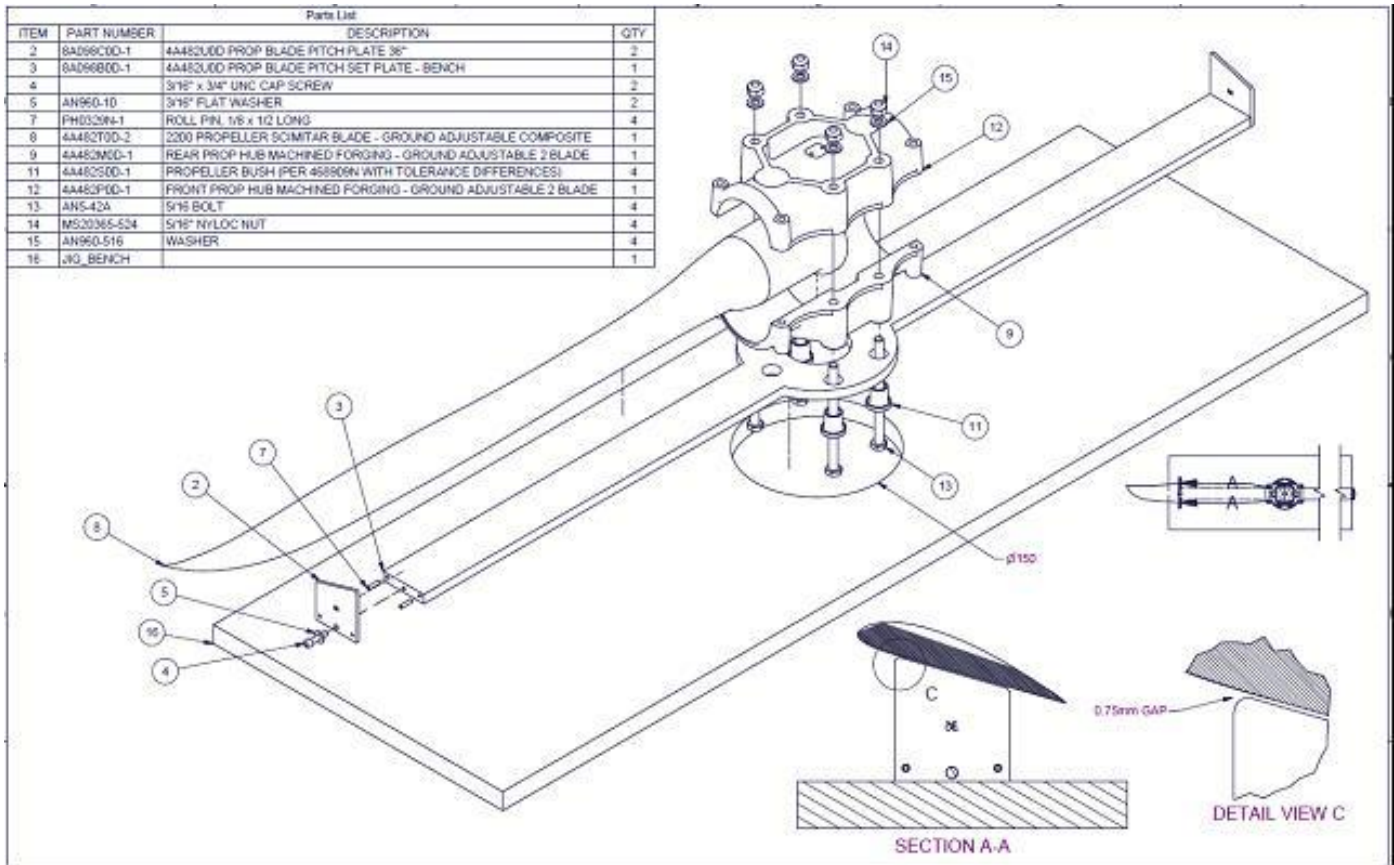

Figure 6 – Pitch Set Jig

4.7.5 Procedure - Propeller installation



Type of Maintenance:	Heavy Maintenance
Level of Certification:	LSA Repairman (Inspection or Maintenance)

- Figure 7 shows typical propeller installation details.
- Ensure that Propeller drive bushes – 6 off, are in place in the Crankshaft Propeller Flange (note that two are special, short parts and face “backwards” compared to the others – see Figure 8). Fit the rear spinner backing plate to the flange.
- When fitting a propeller turn the crank of the engine by hand until the magnets are aligned vertically and then fit the propeller with the blades close to horizontal. This method makes it likely that when the engine is turned off the propeller will naturally tend to come to rest with the blades close to horizontal. Note that this procedure does not apply to 3300 engines as they may stop in any position.
- Fit propeller to flange.
- Fit Propeller Bolts - 4 off. The bolts must be oriented with the nuts positioned furthest from the propeller flange (nuts forward for a standard tractor installation).
- Fit front spinner plate and penny washers to front of propeller. Note the use of AN970 “Penny Washers” – this is required to distribute the load applied by the bolts.
- Ensure that both spinner plates are locating correctly on the spigots of the propeller hub. The rear spinner plate is drilled to allow the rear hub bolt spigots to pass through and mate directly against the propeller flange. There must be nothing between these mating faces.
- Progressively tighten bolts ensuring equal distribution of load and in a normal criss-cross torque sequence. Ensure that the hub is tightened evenly: check that the gap between the front and rear hub plates is the same on both sides of the propeller.
- Using Torque Wrench, tighten propeller mounting bolts to the value given in Table 5.
- Using Torque Wrench, tighten the outer blade clamp bolts to the value given in Table 5.
- Check tracking of Propeller as detailed in Section 4.7.6.
- Locate Spinner on Spinner Flange and fix with Machine Screws through tinnerman Washers.



13. Check Spinner tracking as detailed in Section 4.7.7
14. After the first 5 hours following the propeller installation or adjustment of the hub mounting bolts the spinner must be removed and the propeller bolts checked for correct tension per Table 6.

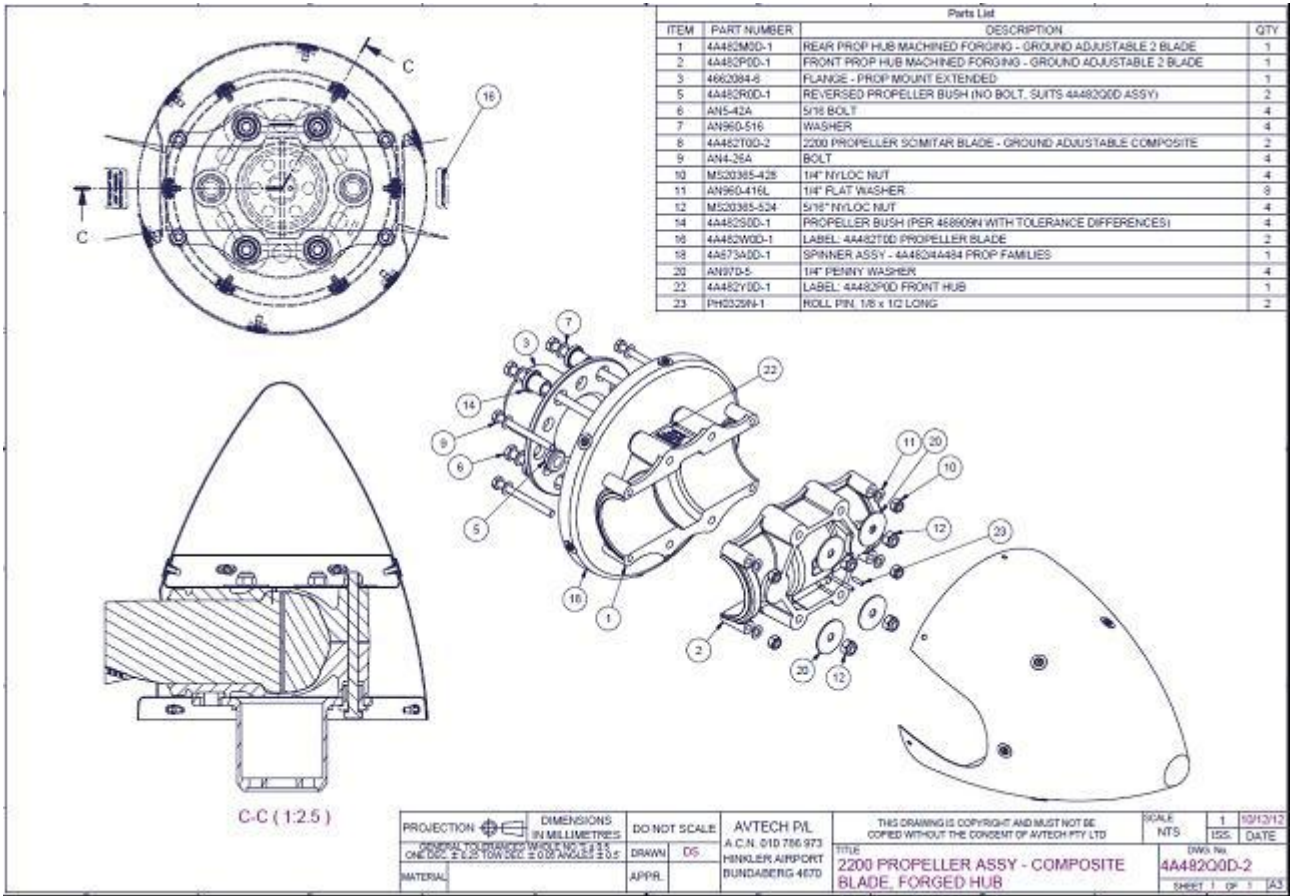

Figure 7 – Typical Propeller Installation

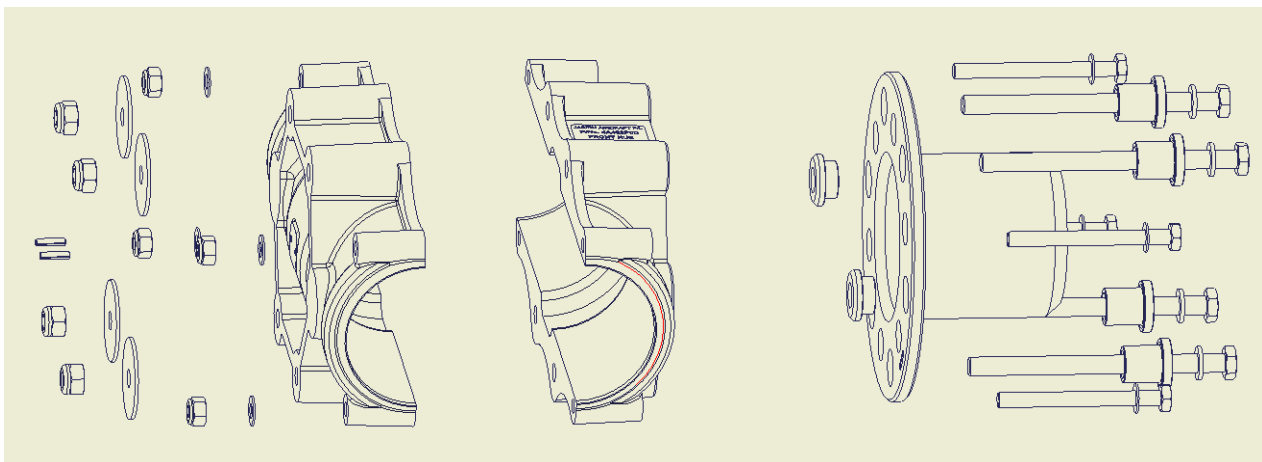

Figure 8 – Propeller Hub Assembly (Spinner and blades not shown)

IMPORTANT

For all Jabiru Aircraft the spinner is an important and integral part of the propeller Assembly. It is essential to ensure adequate engine cooling. The aircraft must not be flown with the spinner removed.

4.7.6 Procedure – Propeller Tracking



Type of Maintenance:	Line Maintenance
Level of Certification:	LSA Repairman (Inspection or Maintenance)

1. Locate a fixed object on a flat floor so that it clears the Propeller tips by a small margin – 1-3mm.
2. Rotate the Propeller by hand.
3. Check that each blade clears the object by the same amount. Measure the clearance for each blade.
4. Maximum Tracking Error Tolerance is +/- 2mm.
5. If the Propeller is outside the approved tolerance, refer to JABIRU Aircraft Pty Ltd or a JABIRU Approved Service Centre for rectification instructions.

4.7.7 Procedure – Spinner Tracking



Type of Maintenance:	Line Maintenance
Level of Certification:	LSA Repairman (Inspection or Maintenance)

1. Locate a fixed object on a flat floor to just clear the lower edge of the tip of the Spinner.
2. Rotate the propeller by hand and check that the Spinner runs true.
3. Correct any run-out by loosening machine screws, realigning spinner then retightening machine screws.

4.7.8 Procedure – Propeller Balance (Maintenance)



Type of Maintenance:	Line Maintenance
Level of Certification:	LSA Repairman (Inspection or Maintenance)

1. Propeller balancing in the course of maintenance follows the same procedure as during a propeller overhaul. Therefore the procedure given in Section 5.6.1 must be used.

4.8 Troubleshooting

4.8.1 Defect Recognition

4.8.1.1 Chips

The trailing edge of the propeller blades are relatively thin and may be damaged more easily than the remainder of the propeller. This type of damage is normally caused in the hangar or while the propeller is in storage or being shipped.

Recommended Actions:

- In general, whitening is a sign that the resin matrix surrounding the fibreglass has been damaged. This type of damage can allow moisture to enter and act as a starting point from which de-laminations can grow.
- If the fibreglass has been chipped or frayed apply a thin type of superglue to the fibres. Capillary action will draw the glue into the glass and the colour will change from white to translucent. Whitening extending up to 10mm along the blade trailing edge may be repaired in this way.
- If the line of the trailing edge has been notched by a small amount (up to 2mm) the notch can be sanded away to leave a smooth trailing edge. This must be done AFTER the glass weave has been stabilised with superglue.
- After repair: visually monitor the chip for growth.

4.8.1.2 Stone Chips

The propellers have been designed to be resistant to abrasion and stone chips, however stone chips may still occur on the rear face of the blade.

Recommended Actions:

- Stone chips are not generally dangerous, however they should be visually monitored during normal daily inspections as it is possible for glass de-laminations to start from them. Using a thin type of superglue to seal the chip is recommended to seal the damage & stabilise the chip.
- Maximum chip size: 8 x 8mm – refer larger chips to Jabiru Aircraft for directions.

4.8.1.3 Urethane Pitting

The propellers have been designed to be resistant to abrasion to the urethane, however over time – especially in rain or when operating from gravel or grass runways – wear will occur.

Recommended Actions:

- Minor damage can be sanded slightly to improve the smoothness of the leading edge.
- Major damage must be repaired by returning the propeller to the manufacturer to replace the urethane leading edge protection.

4.8.1.4 Tip Cracks

The tips of both propellers are relatively susceptible to damage due to their small size.

Recommended Actions:

- Minor damage to the tip may be addressed by grinding the damaged area off the blade: a maximum of 3mm may be removed. Note that to maintain propeller balance the same amount must be removed from both blades.
- Re-balancing of the propeller afterwards is recommended.

Propeller Technical Manual	Jabiru Aircraft Pty Ltd 
JPM0001-3	4A482U0D And 4A484E0D Propellers

5 Propeller Overhaul

5.1 Overhauler Requirements

The following are recommended as the minimum requirements for someone carrying out overhauls on Jabiru Propellers:

1. Facilities

- Enclosed workspace with sealed floor, lighting, compressed air & mains electricity.

2. Training

- Completion of an approved instruction course specific to Jabiru Propellers. Approved courses include those offered by Jabiru Aircraft Australia or by local Jabiru Aircraft representatives.

3. Rating

- Commercial maintainers must hold ratings required by their local Airworthiness Authority.

4. Experience

- A minimum of 1 year experience working on propellers under supervision is recommended for commercial maintainers before working un-supervised.

5.2 Tool & Gauge Control

- As detailed in Section 4.3

5.3 Tools & Equipment:

Access to the following tools will be required. All tools must be good quality items:

- As detailed in Section 4.4

5.3.1 Propeller Balancing

- A basic propeller balance rig consists of 2 straight, level “knife edges”. Steel rulers are suitable when appropriately mounted.
- The rig must be constructed to allow checking of the blades in the horizontal and vertical positions.
- For balancing the propeller must be mounted on a shaft positioned at the propeller’s axis of rotation. This is usually a propeller flange fitted to a crankshaft (or similar heavy, round shaft). The propeller is fitted to the propeller flange with 4 off 5/16” drive bushes and bolts. The heavy shaft is then mounted on the “knife edges” with the propeller cantilevered over 1 side of the jig. This method allows the balance jig to be much less bulky and mounts the propeller as it would be on the engine to minimise balance differences.
- Ensure the balancing is being done in a closed room – drafts or gusts of wind will rotate the propeller and give inconsistent balancing.
- Propeller balance jigs must be checked before each use to ensure that:
 - The “knife edge” balance blades are horizontal
 - There are no bends, dents, nicks or damage to the “knife edges” or the balance shaft which may prevent the assembly from rotating.

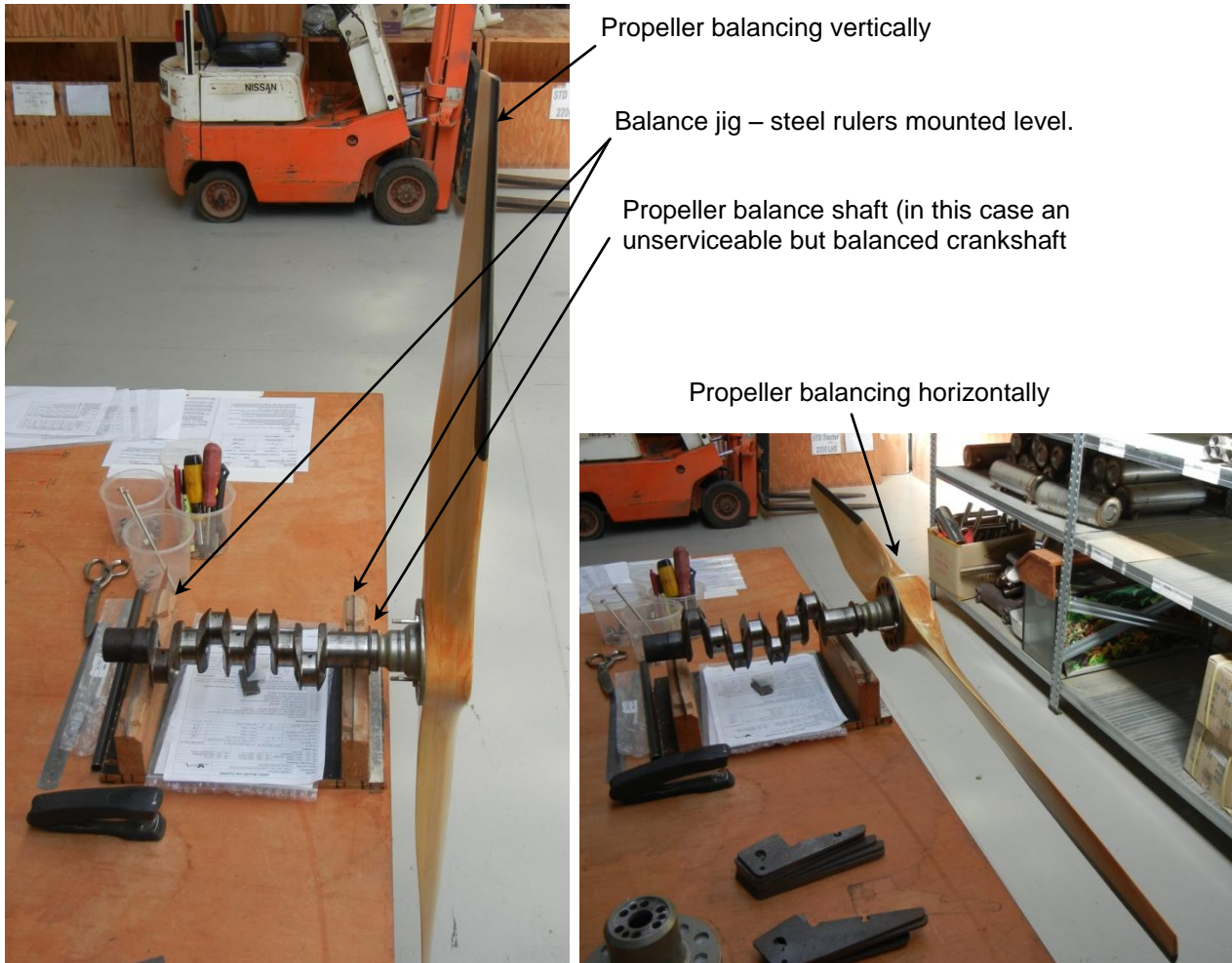

Figure 9 – Propeller Balancing

5.4 Overhaul Sequence



1. Remove the propeller from the aircraft
2. Thoroughly clean & inspect the propeller.
3. Discard and replace all hardware (nuts & bolts) with new parts. Note that aircraft grade hardware must be used.
4. Carry out the standard inspections (propeller removed) detailed in Section 5.5.
5. Carry out any necessary repairs as detailed in Section 5.6.
6. Carry out a final balance of the propeller as detailed in Section 5.6.1.
7. Re-fit the propeller to the aircraft as detailed in Section 4.7.3.
8. Ensure the propeller blades and spinner are tracking correctly - Section 4.7.6 & 4.7.7.

5.5 Propeller Removed Inspections



Type of Maintenance:	Overhaul
Level of Certification:	LSA Repairman (Inspection or Maintenance), with Task Specific Training

Whenever the propeller is removed from the engine, the following inspections are to be carried out:

1. **Drive bush fit into hub** – should be a good fit. The bush should not need to be forced into the hub and there must be no slop once the bush is fitted.
2. **Balancing** – Balance in accordance with Section 5.3.1. Alternatively, operators seeking more accurate balance may return both propeller blades to the manufacturer for fine balancing.
3. **Hub condition inspection** – whenever the propeller is off the engine the general condition of the hub should be visually inspected. Section 5.6.2 gives details.

4. **Dye Penetrant Inspection** - Carry out a Dye Penetrant inspection of the front and rear hubs. If cracking or defects are identified provide clear photographs to Jabiru Aircraft Pty Ltd for assessment.

5.6 Repair Methods

5.6.1 Propeller Balancing Procedure (Overhaul)



Type of Maintenance:	Overhaul
Level of Certification:	LSA Repairman (Inspection or Maintenance), with Task Specific Training

- Both propellers are balanced during manufacture using a method able to detect very small imbalances between blades.
- If an imbalance is detected in the propeller assembly during overhaul it is recommended that BOTH blades be returned to the manufacturer for re-balancing.
- The following procedure is given as a basic check of balance which may be done in the field however accuracy of this process is not as high as using the factory balancer.
- Propeller balance jigs must meet the requirements of Section 5.3.1.
- Check the balance jig to ensure that the “knife edges” are straight and level.
- Ensure the propeller is clean and dry: if necessary, clean the blades to ensure all deposits are removed then dry thoroughly.
- Fit the propeller to the balance shaft.
- Place the propeller on the rig, with the balance shaft resting on the knife edges. Initially test with the propeller blades horizontal: the heavier blade will sink to the bottom.
- Repeat the test with the propeller blades vertical: the heavier side of the propeller will sink towards the bottom.
- Ensure the balancing is being done in a closed room – drafts or gusts of wind will rotate the propeller and give inconsistent balancing.
- The balance may only be corrected by the application of enamel paint. Any other method of securing balance is PROHIBITED.
- Do not apply paint over the Urethane leading edge – it will rapidly flake off in service which is both unsightly and will affect the balance of the propeller.
- Propellers outside these limits should be rejected as unserviceable or returned to JABIRU for assessment and possible repair.

Tolerances:

- Imbalance shall not exceed the following limit whatever the position of the Propeller in the plane of rotation: 750 mm-gms (approximately 1 gm at the tip).

5.6.2 Damage Limits & Repairs

Any service or repair must take account of the risk of subsequent Propeller failure. Therefore repairs by owners are limited to minor damage. Larger damage must be referred to Jabiru Aircraft for repair.

Only damage within the size tolerances described in Section 4.8.1 may be repaired by owners. All propellers with damage beyond these limits must be either rejected as unserviceable or returned to JABIRU Aircraft Pty Ltd or our local approved agent for assessment and possible repair.

5.6.3 General

Repairs must always take account of the changes to balance of the Propeller. Generally for repairs the propeller should be removed in accordance with the procedure described above (Section 4.7.2) and checked for balance (Section 5.6.1) prior to refitting (Section 4.7.3). Always check blade & spinner tracking after reassembly (Section 4.7.3).

Propeller Technical Manual	Jabiru Aircraft Pty Ltd 
JPM0001-3	4A482U0D And 4A484E0D Propellers

6 Reporting

6.1.1 Continued Operational Safety Reporting

The owner/operator of a LSA is responsible for notifying the manufacturer of any safety of flight issue or significant service difficulty upon discovery. The following proforma may be used:

Date:	
Aircraft Model	
Aircraft Registration	
Aircraft S/No.	
Propeller Model:	
Propeller S/No.	
Details of item:	
Name of Reporter:	
Preferred Contact Details of Reporter	

6.1.2 Owner Change of Address Notice

Each owner/operator of a LSA is responsible for providing the manufacturer with current contact information where the manufacturer may send the owner/operator supplemental notification bulletins. The following proforma may be used & sent to Jabiru Aircraft at info@jabiru.net.au or the contact details given in Section 2.2.

Aircraft Model	
Aircraft Registration	
Propeller Model:	
Propeller S/No.	
Aircraft S/No	
Previous Owner:	
New Owner:	
Contact Details of New Owner	

7 Appendix A – Worksheets

The worksheet provided covers all inspection tasks required for 100 hour, Annual Inspections and 500 hourly inspections. '500 hourly' tasks are completed every 500 hours, 'Annual' tasks are done both annually and every 500 hours. '100 hourly' tasks are to be completed at 500 hour, Annual and 100 hour inspection intervals. This worksheet can also be used for inspections conducted 5 hours after any hub bolt adjustments is desired (The tasks required for this inspection are listed in Table 6 – Inspection Chart) 'P' indicates pass, 'F' indicates fail, the 'Comments' column should be used to note condition, parts replaced, etc.

INSPECTION TYPE (circle).....100 hourly.....Annual.....500 hourly
 CARRIED OUT BY (print name).....(signature).....(date).....

7.1.1.1 Spinner

General condition – check for cracks, delamination etc

P	F	Comments:	100 hourly

Screw holes – check hole do not have excessive elongation

P	F	Comments:	100 hourly

7.1.1.2 Spinner Flange

General condition – Cracks around the perimeter of hub, delamination etc

P	F	Comments:	100 hourly

Anchor nuts & rivets – Check condition, ensure they are secure

P	F	Comments:	100 hourly

Visual Inspection – Look for signs of fretting and looseness (rubbing marks)

P	F	Comments:	100 hourly

7.1.1.3 Spinner Screws

General condition – Check condition of the head and thread of each screw

P	F	Comments:	100 hourly

Screw tightness – check screw tightness adequately in anchor nuts, replace if fittings are loose

P	F	Comments:	100 hourly

7.1.1.4 Propeller

Urethane condition – Check condition of Urethane Leading edge

P	F	Comments:	100 hourly

Blade condition - Check blade for general condition, glass de-lamination and cracks.

P	F	Comments:	100 hourly

Propeller Technical Manual	Jabiru Aircraft Pty Ltd 
JPM0001-3	4A482U0D And 4A484E0D Propellers

Hub Condition – Check condition

P	F	Comments:	100 hourly

Propeller Drive Bush Fit - Test the fit of the propeller drive bushes as detailed in Section 5.5

P	F	Comments:	Annual

Blade Pitch (Unpinned Blades only) – see section 4.7.4

P	F	Comments:	500 hourly

Propeller Blade Stem Inspection - Inspect the blade stems for cracking, abrasion or deposits. Where equipped, inspect the condition of the blade pitch locking pins.

P	F	Comments:	500 hourly

Hub Dye Penetrate Inspection – Conduct for both front and rear hubs

P	F	Comments:	500 hourly

7.1.1.5 Propeller bolts & nuts

General condition – Check for corrosion, wear etc

P	F	Comments:	100 hourly

Bolt tension – Check correct tension

P	F	Comments:	100 hourly

7.1.1.6 Tracking

Propeller tracking – See section 4.7.6

P	F	Comments:	100 hourly

Spinner tracking – See section 4.7.7

P	F	Comments:	100 hourly

7.1.1.7 Balance

Check propeller balance – See section 4.7.8

P	F	Comments:	Annual

7.1.1.8 Propeller Flange – Crankshaft Screws

Check Tension as per Table 5

P	F	Comments:	500 hourly