

TRIUMPH

OWNERS HANDBOOK

MANUEL DU CONDUCTEUR

BESITZERHANDBUCH

Foreword

This handbook contains information on the Triumph T595 Daytona and T509 Speed Triple motorcycles. Always store this handbook with the motorcycle.

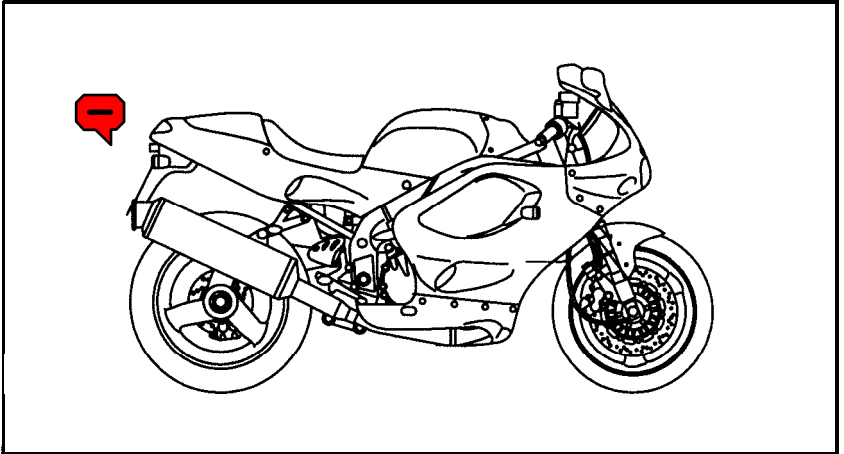

Warning Labels

At certain areas of the motorcycle, the symbol (right) can be seen. The symbol means 'CAUTION: REFER TO THE HANDBOOK' and will be followed by a pictorial representation of the subject concerned. Never attempt to ride the motorcycle or make any adjustments without reference to the relevant instructions contained in this handbook. See pages 8 and 9 for the location of all labels bearing this symbol. Where necessary, this symbol will also appear on the pages containing the relevant information.

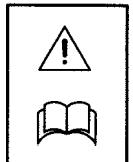

Maintenance

To ensure a long, safe and trouble free life for your motorcycle, maintenance should always be carried out by an authorised Triumph dealer. Only an authorised Triumph dealer will have the necessary knowledge, equipment and skills to maintain your Triumph motorcycle correctly.

Information

The information contained in this publication is based on the latest information available at the time of printing. Triumph reserves the right to make changes at any time without prior notice, or obligation.

Not to be reproduced wholly or in part without the written permission of Triumph Motorcycles Limited. © 1996 Triumph Motorcycles Limited, Hinckley, Leicestershire, England.

Publication part number 3855001 issue 2.

Foreword

Owner's Handbook

Thank you for choosing a Triumph motorcycle. This motorcycle is the product of Triumph's use of proven engineering, exhaustive testing, and continuous striving for superior reliability, safety and performance. Please read this owner's handbook before riding in order to become thoroughly familiar with the correct operation of your motorcycle's controls, its features, capabilities and limitations.

This handbook includes safe riding tips, but does not contain all the techniques and skills necessary to ride a motorcycle safely. Triumph strongly recommends that all riders undertake the necessary training to ensure safe operation of this motorcycle.

A WARNING: This owner's handbook and all other instructions which are supplied with your motorcycle should be considered a permanent part of your motorcycle and should remain with it even if your motorcycle is subsequently sold.

All riders must read this owner's handbook and all other instructions which are supplied with your motorcycle before riding in order to become thoroughly familiar with the correct operation of your motorcycle's controls, its features, capabilities and limitations. Do not lend your motorcycle to others as riding when not familiar with your motorcycle's controls, features, capabilities and limitations can lead to an accident.

Table of Contents

This handbook contains a number of different sections. The table of contents below will help you find the beginning of each section where, in the case of the major sections, a further table of contents will help you find the specific subject required.

Foreword.....	1
Warning Labels	8
Parts Identification	10
Serial Numbers.....	13
General Information.....	15
How to Ride the Motorcycle.....	27
Accessories, Loading and Passengers	34
Maintenance and Adjustment.....	37
Storage	73
Specifications.....	74
Alphabetical Index	78

Foreword – Safety First

WARNING, CAUTION AND NOTE

Throughout this owner's handbook particularly important information is presented in the following form:

 **WARNING:** This warning symbol identifies special instructions or procedures which, if not correctly followed could result in personal injury, or loss of life.

 **CAUTION:** This caution symbol identifies special instructions or procedures which, if not strictly observed, could result in damage to, or destruction of, equipment.

NOTE:

- This note symbol indicates points of particular interest for more efficient and convenient operation.

NOISE CONTROL SYSTEM

TAMPERING WITH NOISE CONTROL SYSTEM PROHIBITED

Owners are warned that the law may prohibit:

- (a) The removal or rendering inoperative by any person other than for purposes of maintenance, repair or replacement, of any device or element of design incorporated into any new vehicle for the purpose of noise control prior to its sale or delivery to the ultimate purchaser or while it is in use; and
- (b) the use of the vehicle after such device or element of design has been removed or rendered inoperative by any person.

Foreword - Safety First

A WARNING: This motorcycle is designed for on-road use only. It is not suitable for off-road use.

Off-road operation could lead to loss of control of the motorcycle resulting in an accident causing injury or loss of life.

A WARNING: Never start your engine or let it run for any length of time in a closed area. The exhaust fumes are poisonous and may cause loss of consciousness and death within a short time. Always operate your motorcycle in the open-air or in an area with adequate ventilation.

A WARNING: This motorcycle is not designed to tow a trailer or be fitted with a sidecar. Fitting a sidecar and/or a trailer may result in loss of control and an accident.

A WARNING: This motorcycle is designed for use as a two-wheeled vehicle capable of carrying a rider on his own, or a rider and one passenger (subject to a passenger seat being fitted).

The total weight of the rider, and any passenger, accessories and luggage must not exceed the maximum load limit of 185 kg (407 lbs).

A WARNING: PETROL IS HIGHLY FLAMMABLE:

Always turn off the engine when refuelling.

Do not refuel or open the fuel filler cap while smoking or in the vicinity of any naked flame.

Take care not to spill any petrol on the engine, exhaust pipes or silencers when refuelling.

If petrol is swallowed, inhaled or allowed to get into the eyes, seek immediate medical attention.

Spillage on the skin should be immediately washed off with soap and water and clothing soiled with petrol should immediately be removed.

Burns and other serious skin conditions may result from contact with petrol.

A WARNING: The rider must maintain control of the vehicle by keeping hands on the handlebars at all times.

The handling and stability of a motorcycle will be adversely affected if the rider removes his hands from the handlebars, resulting in loss of control or an accident.

Foreword – Safety First

A **WARNING:** Always turn off the engine and remove the ignition key before leaving the motorcycle unattended. By removing the key, the risk of use of the motorcycle by unauthorised or untrained persons is reduced.

When parking the motorcycle, always remember the following:-

The engine and exhaust system will be hot after riding. **DO NOT** park where pedestrians, animals and/or children are likely to touch the motorcycle.

Do not park on soft ground or on a steeply inclined surface. Parking under these conditions may cause the motorcycle to fall over.

For further details, please refer to the 'How to Ride the Motorcycle' section of this owner's handbook.

A **WARNING:** Footrests provided must always be used by rider and passenger during operation of the vehicle.

By using the footrests, both rider and passenger will reduce the risk of inadvertent contact with any motorcycle components and will also reduce the risk of injury from entrapment of clothing.

A **WARNING:** Never ride the motorcycle when fatigued or under the influence of alcohol or other drugs.

Riding when fatigued or under the influence of alcohol or other drugs reduces the rider's ability to maintain control of motorcycle and may lead to loss of control and an accident.

Riding when under the influence of alcohol or other drugs is illegal.

A **WARNING: GRINDING OF MAGNESIUM ALLOY PARTS**

Magnesium alloy grinding fines are highly flammable.

Always ensure that correct procedures and equipment are used to avoid the risk of fire. Suitable protective flame-resistant clothing must be worn. Never permit naked flames, cutting and welding operations or smoking in the working area.

Magnesium alloy components incorporated in this motorcycle include, engine covers, cam cover and the headlight support.

A **WARNING:** Always ride defensively and wear the protective equipment mentioned elsewhere in this foreword. Remember, in an accident, a motorcycle does not give the same impact protection as a car.

Foreword – Safety First

A WARNING: Use of a motorcycle with bank angle indicators worn beyond the maximum limit (when 10mm or more of the radiused tip of either front footrest is worn away) will allow the motorcycle to be banked to an unsafe angle.

Never change the setting of the gearchange rod or brake pedal pushrod as this may adversely affect the bank angle at which the bank angle indicators contact the ground.

Banking to an unsafe angle may cause instability, loss of control and an accident causing injury or death.

A WARNING: Ensure all equipment which is required by law is installed and functioning correctly.

The removal or alteration of the motorcycles lights, silencers, emission or noise control systems can violate the law.

Incorrect or improper modification may adversely affect the handling, stability or other aspect of the motorcycle operation which may result in an accident causing injury or death.

A WARNING: If the motorcycle is involved in an accident or collision it must be taken to an authorised Triumph dealer for inspection and repair. Any accident can cause damage to the motorcycle which, if not correctly repaired, may cause a second accident which may result in injury or death.

A WARNING: Consult your authorised Triumph dealer whenever there is doubt as to the correct or safe operation of this Triumph motorcycle.

Remember that continued operation of an incorrectly performing motorcycle may aggravate the fault and may also prejudice safety.

A WARNING: When riding the motorcycle both rider and passenger must always wear a crash helmet, eye protection, gloves, trousers (close fitting around the knee and ankle) and a brightly coloured jacket. Brightly coloured clothing will considerably increase a rider's (or passenger's) visibility to other operators of road vehicles. Although full protection is not possible, wearing correct protective clothing can reduce the risk of injury when riding.

A WARNING: A crash helmet is one of the most important pieces of riding gear as it offers protection against head injuries. You and your passenger's crash helmet should be carefully chosen and should fit you or your passenger's head comfortably and securely. A brightly coloured helmet will increase a rider's (or passenger's) visibility to other operators of road vehicles.

An open face helmet offers some protection in an accident though a full face helmet will offer more.

Always wear a visor or approved goggles to help vision and to protect your eyes.

Foreword - Safety First

A WARNING: Owners should be aware that the only approved parts, accessories and conversions for any Triumph motorcycle are those which carry official Triumph approval and are fitted to the motorcycle by an authorised dealer.

Triumph does not accept any liability whatsoever for defects caused by the fitting of non-approved parts, accessories or conversions or the fitting of any approved parts, accessories or conversions by non-approved personnel.

In particular, it is extremely hazardous to fit or replace parts or accessories whose fitting requires the dismantling of, or addition to, either the electrical or fuel systems and any such modification could cause a safety hazard.

The fitting of any non-approved parts, accessories or conversions may adversely affect the handling, stability or other aspect of the motorcycle operation which may result in an accident causing injury or death.

A WARNING: This Triumph motorcycle should be operated within the legal speed limits for the particular road travelled.

Operating a motorcycle at high speeds can be potentially dangerous since the time available to react to given traffic situations is greatly reduced as road speed increases.

Always reduce speed in potentially hazardous driving conditions such as bad weather or heavy traffic.

A WARNING: Continually observe and react to changes in road surface, traffic and wind conditions. All two-wheeled vehicles are subject to external forces which may cause an accident. These forces include but are not limited to:

- Wind draft from passing vehicles
- Uneven or holed road surfaces.
- Bad weather.
- Rider error.

Always operate the motorcycle at moderate speed and away from heavy traffic until you have become thoroughly familiar with its handling and operating characteristics. Never exceed the legal speed limit.

Warning Labels

WARNING LABEL LOCATION

The labels detailed on this and the following page draw your attention to information in this handbook. Before riding, ensure that all riders have understood and complied with all the information to which these labels relate.

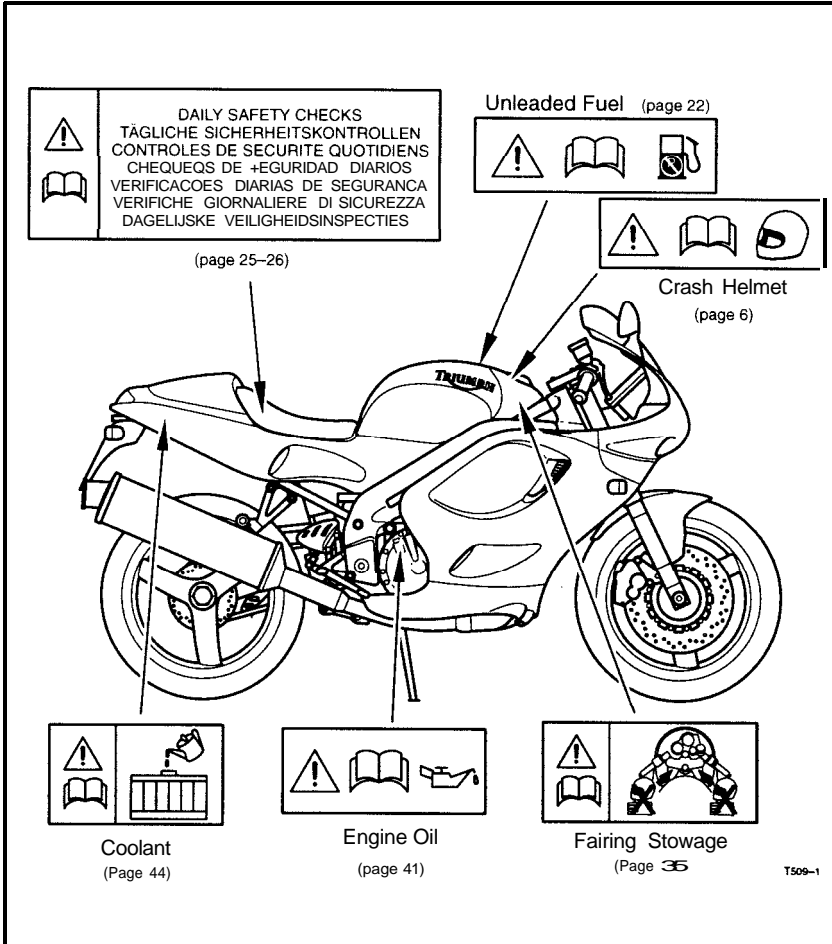

Warning Labels

WARNING LABEL LOCATION (continued)

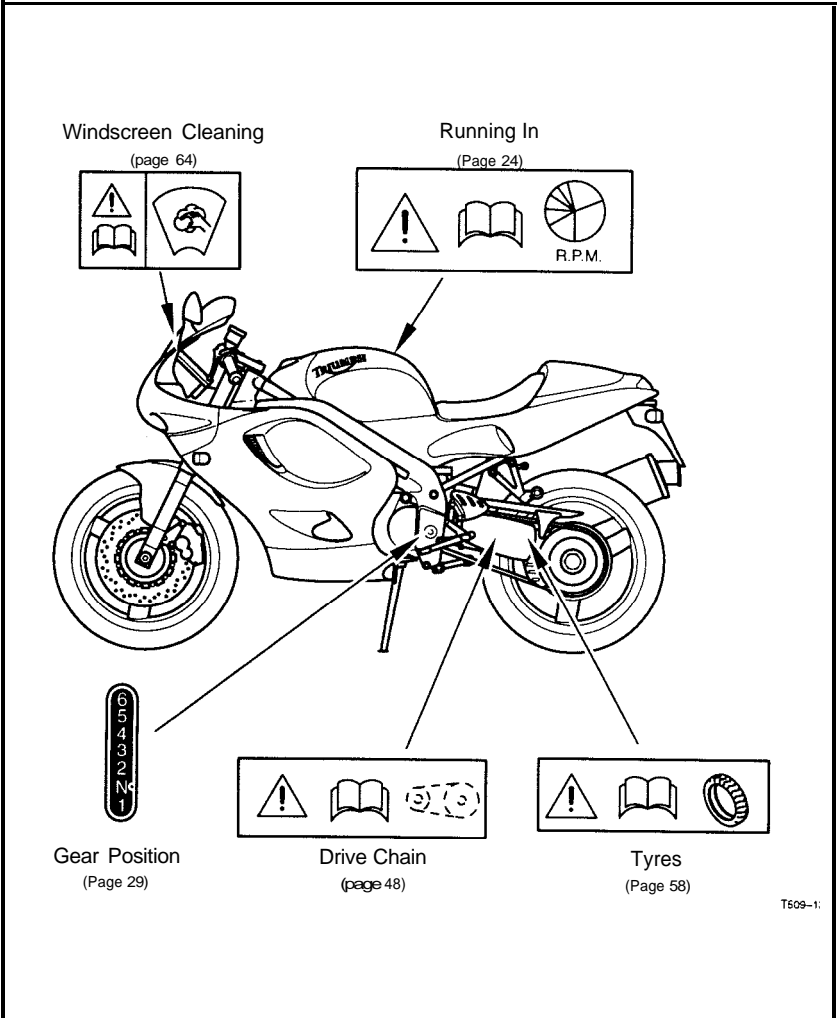

T609-1:

Parts Identification

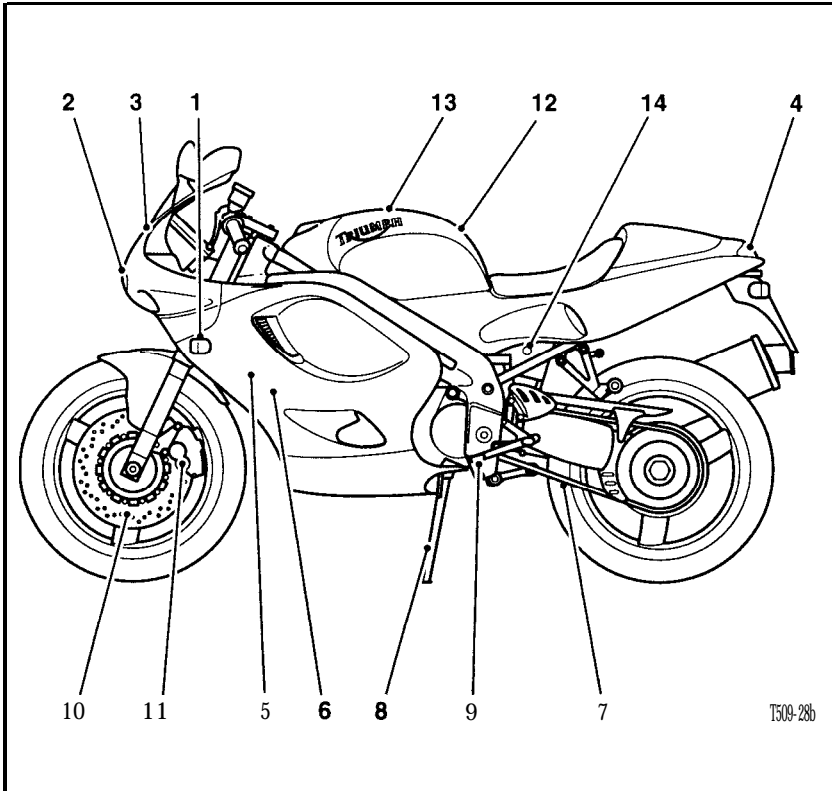

- | | |
|------------------|-------------------------|
| 1. indicator | 8. Side Stand |
| 2. Headlamp | 9. Gearchange Pedal |
| 3. Position Lamp | 10. Front Brake Disc |
| 4. Rear Lamp | 11. Front Brake Caliper |
| 5. Radiator | 12. Fuel Tank |
| 6. Oil Cooler | 13. Fuel Filler Cap |
| 7. Drive Chain | 14. Seat Lock |

Parts Identification

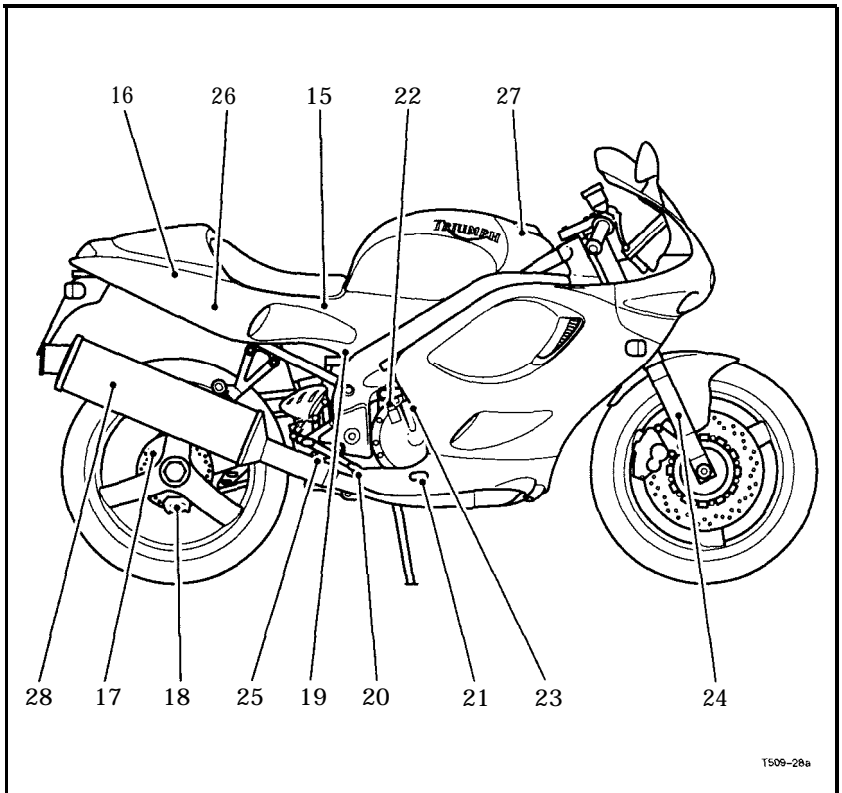

15. Battery

16. Tool Kit

17. Rear Brake Disc

18. Rear Brake Caliper

19. Rear Brake Fluid Reservoir

20. Rear Brake Pedal

21. Oil Level Sight Glass

22. Oil Filler Plug

23. Clutch Cable

24. Front Fork

25. Rear Suspension Unit

26. Coolant Expansion Tank

27. Coolant Pressure Cap

28. Silencer

Parts Identification

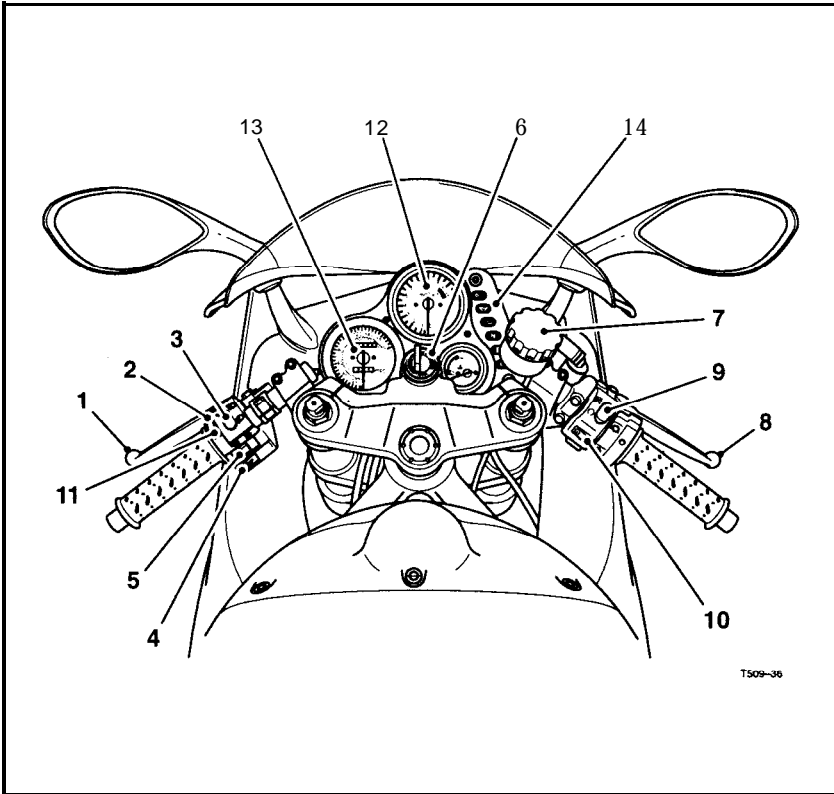

T509-36

- | | |
|--------------------------------|-----------------------|
| 1. Clutch Lever | 8. Front Brake Lever |
| 2. Passing Button | 9. Engine Stop Switch |
| 3. Headlamp Dipswitch | 10. Starter Button |
| 4. Horn Button | 11. Headlight Switch |
| 5. Indicator Switch | 12. Tachometer |
| 6. Ignition Switch | 13. Speedometer |
| 7. Front Brake Fluid Reservoir | 14. Warning Lights |

Serial Numbers

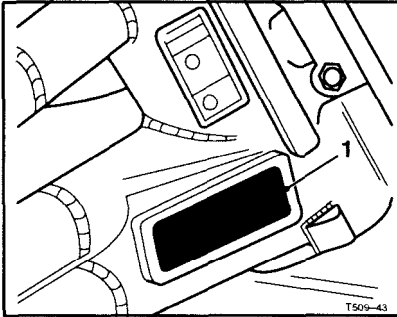

1. V.I.N. Number

Vehicle Identification Number (UN.)

The vehicle identification number is stamped into the steering head. It is also displayed on a plate, riveted to the frame, immediately behind the steering head.

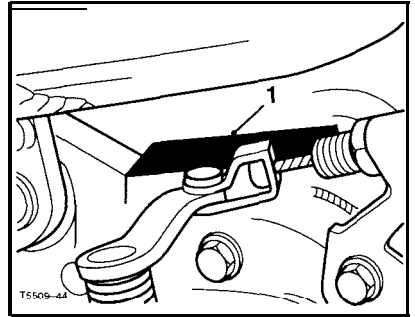

1. Engine Serial Number

Engine Serial Number

The engine serial number is stamped on the crankcase, immediately above the clutch cover.

Serial Numbers

THIS PAGE IS INTENTIONALLY FREE FROM INFORMATION

General Information

Contents

instrument Panel Layout	16
Speedometer	16
Tachometer	16
Coolant Temperature Gauge	17
Warning Lights	17
Ignition Key	18
Ignition Switch/Steering Lock	18
Brake Lever Adjuster	19
Right Handlebar Switches	20
Left Handlebar Switches	21
Fuel Requirement	22
Fuel Tank Cap	22
Stand	23
Tool Kit	23
Handbook Storage	23
Seat Lock Operation/Seat Removal	23
Running-in	24
Safe Operation	25

General Information

INSTRUMENT PANEL LAYOUT

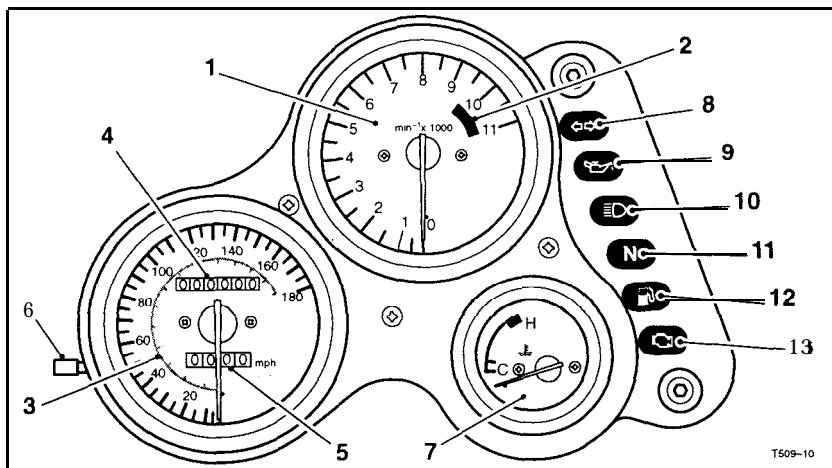

1. Tachometer
2. Tachometer 'Red Zone'
3. Speedometer
4. Odometer
5. Trip Meter
6. Trip Meter Reset Knob
7. Coolant Temperature Gauge

SPEEDOMETER

The speedometer indicates the road speed of the motorcycle.

In the speedometer face are the odometer and trip meter. The odometer shows the total distance that the motorcycle has travelled. The trip meter shows the distance travelled since the meter was last reset to zero. The trip meter can be reset to zero by rotating the reset knob situated on the left hand side of the speedometer.

TACHOMETER

The tachometer shows the engine speed in revolutions per minute - rpm (r/min). On the right side of the tachometer face is the 'red

8. Turn Indicator light
9. Low Oil Pressure Warning Light
10. High Beam Indicator Light
11. Neutral Indicator Light
12. Low Fuel Level Indicator Light
13. Engine Management Malfunction Indicator Light

zone'. Engine rpm (r/min) in the red zone is above maximum recommended engine speed and is also above the range for best performance.



CAUTION: Never allow engine RPM to enter the 'red zone' as severe engine damage may result.

NOTE

- The 'Red Zone' position for Daytona is different to that on the Speed Triple.

General Information

COOLANT TEMPERATURE GAUGE

The coolant temperature gauge indicates the temperature of the engine coolant. On the right-hand side of the gauge face is the 'red zone'. If the temperature gauge needle moves into the 'red zone' this indicates that the engine is overheating.



CAUTION: Do not continue to run the engine if the gauge needle enters the "red zone" as severe engine damage may result.

WARNING LIGHTS



INDICATORS When the indicator switch is turned to left or right, the corresponding direction indicator light flashes on and off.



LOW OIL PRESSURE: The low oil pressure warning light becomes illuminated whenever the oil pressure is dangerously low (or the ignition switch is in the 'ON' position with the engine not running). When the engine is running, the light will remain off when sufficient oil pressure is present.

When starting the motorcycle, check that the light comes on when the ignition is in the 'ON' position, but goes out as soon as the engine starts



CAUTION: Stop the engine immediately if the low oil pressure warning light comes on during normal operation. Do not restart the engine until the fault has been rectified.

Severe engine damage will result from running the engine when the oil warning light is illuminated.



HIGH BEAM: When the headlights are switched on and the headlight dip switch is set to 'high beam', the high beam warning light will illuminate.



NEUTRAL: The neutral warning light indicates when the transmission is in neutral (no gear selected). The warning light will illuminate when the transmission is in neutral with ignition switch in the 'ON' position.



LOW FUEL: The low fuel indicator will illuminate when there are approximately 3.7 litres of fuel remaining in the tank.



ENGINE MANAGEMENT SYSTEM MALFUNCTION INDICATOR LIGHT:

The malfunction indicator light for the engine management system illuminates when the ignition is switched on, remains illuminated during starting, and goes out shortly after the engine starts.

If the malfunction indicator light becomes illuminated during riding, a fault has occurred in the engine management system. In this case the system will switch to 'limp-home' mode so that riding may continue. Contact an authorised Triumph dealer as soon as possible to have the fault checked out and rectified.



WARNING: Do not continue to ride for a long period with the malfunction indicator light illuminated. The fault which has occurred may affect engine performance and fuel consumption. Reduced engine performance could cause a dangerous riding condition, leading to loss of control and an accident

General Information

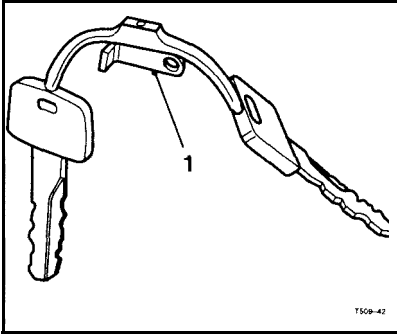

1. Key Number Tag

IGNITION KEY

In addition to operating the steering lock/ignition switch, the ignition key is required to operate the seat lock and fuel tank cap.

When the motorcycle is delivered from the factory, two keys are supplied together with a small tag bearing the key number. Make a note of the key number and store the spare key and key number tag in a safe place away from the motorcycle.

Your authorised Triumph dealer can supply a replacement key cut from details of the key number or can cut a new key using the original as a master.



CAUTION: Do not store the spare key with the motorcycle as this will reduce all aspects of security.

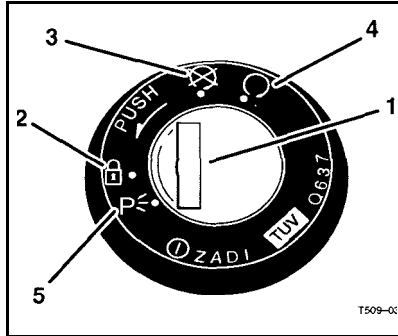

1. Ignition Switch/Steering Lock
2. LOCK position
3. OFF position
4. ON position
5. P (Park) position

IGNITION SWITCH/STEERING LOCK

This is a four position, key operated switch. The key can be removed from the switch only when it is in the OFF, LOCK or P (PARK) position.





TO LOCK: Turn the key to the 'OFF' position, push and fully release the key, then rotate it to the 'LOCK' position.

'PARKING': Turn the key from the 'LOCK' position to the 'P' position. The steering remains locked.

NOTE:

- Do not leave the steering lock in the 'P' position for long periods as this will cause the battery to discharge.

General Information

	Engine off. All electrical circuits off.
	Engine on. All electrical equipment can be used.
	Steering locked. Engine off. All electrical circuits off.
	Steering locked. Engine off. Tail, side and licence plate lights on, all other electrical circuits cut off.

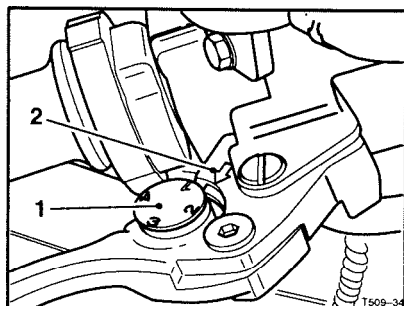

1. Lever Adjuster Wheel
2. Triangular Reference Mark

BRAKE LEVER ADJUSTER

An adjuster is fitted to the front brake lever. The adjuster allows the distance from the handlebar to the brake lever to be changed one of four positions, to suit the span of the operator's hands.

To adjust the lever, push the lever forward and turn the adjuster wheel to align one of the numbered positions with the triangular mark on the lever holder.

The distance from the hand grip to the released lever is shortest when set to number four and longest when set to number one.

⚠ WARNING: For reasons of security and safety, always turn the ignition to 'OFF' and remove the key when leaving the motorcycle unattended.

Any unauthorised use of the motorcycle may cause injury to the user, other road users and pedestrians and may also cause damage to the motorcycle.

A WARNING: With the key in the 'LOCK' or 'P' position the steering will become locked.

Never turn the key to 'Lock' or 'P' while the motorcycle is moving as the steering will lock. Locked steering will cause loss of control and an accident.

A WARNING: Do not attempt to adjust the brake lever with the motorcycle in motion as this may lead to loss of control and an accident.

After adjusting the lever, operate the motorcycle in an area free from traffic to gain familiarity with the new lever setting. Do not loan your motorcycle to anyone as they may change the lever setting from the one you are familiar with causing loss of control or an accident.

General Information

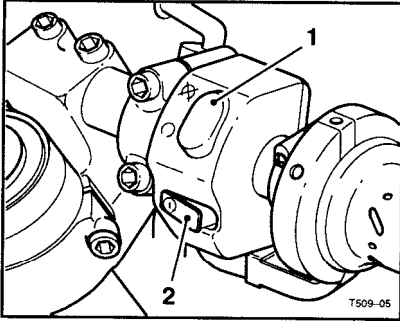



1. Engine Stop Switch
2. Starter Button

RIGHT HANDLEBAR SWITCHES



Engine Stop Switch

In addition to the ignition switch being turned to the 'ON' position, the engine stop switch must be in the  position for the motorcycle to operate.

The engine stop switch is for emergency use. If an emergency arises which requires the engine to be stopped, move the engine stop switch to the  position.

NOTE:

- Although the engine stop switch stops the engine, it does not turn off all the electrical circuits. Ordinarily, the ignition switch should be used to stop the engine.



CAUTION: Do not leave the ignition switch in the 'ON' position unless the engine is running as this may cause damage to electrical components and the battery.



Starter Button

The starter button operates the electric starter. For the starter to operate, the transmission must be in neutral and the clutch lever pulled to the handlebar.

NOTE:

- Even if the clutch lever is pulled in, the starter will not operate if the side stand is down and a gear is engaged.

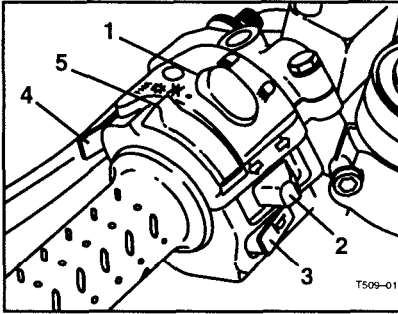

General Information



1. Headlight Dip Switch
2. Direction Indicator Switch
3. Horn Button
4. Passing Button
5. Headlight Switch

LEFT HANDLEBAR SWITCHES

Headlight Switch

0	The headlight is turned off when the switch is in the OFF position.
	The side, tail, licence plate, and instrument lights come on if the switch is pushed to the first position with the ignition switch in the ON position.
	The head, side, tail, licence plate and instrument lights come on if the switch is pushed forward to the second position with the ignition in the ON position.





Headlight Dip Switch

High or low beam can be selected with the headlight dip switch. To select high beam, push the switch forward. To select low beam, push the switch rearwards.

When the high beam is turned on, the high beam warning light will illuminate.



Direction Indicator Switch

When the indicator switch is pushed to  (left) or  (right) and released, the corresponding indicator flashes.

To turn off the indicators, push and release the switch.



Horn Button

When the horn button is pushed, with the ignition switch turned to the 'ON' position, the horn will sound.



Pass Button

When the pass button is pressed, the headlight main beam will be switched on. It will remain on as long as the button is held in and will turn off as soon as the button is released.

General Information

FUEL REQUIREMENT

Your Triumph engine is designed to use unleaded petrol and will give optimum performance if this fuel is used.

Always use unleaded fuel with an octane rating of 95 RON or higher.



CAUTION: The use of leaded petrol is illegal in some countries, states or territories.

Refuelling

Avoid filling the tank in rainy or dusty conditions where airborne material can contaminate the fuel.



CAUTION: Contaminated fuel may cause damage to fuel system components.



WARNING: Petrol (fuel) is highly flammable and can be explosive under certain conditions. When refuelling, turn the ignition switch to the 'OFF' position.

Do not smoke.

Make sure the refuelling area is well ventilated and free from any source of flame or sparks. This includes any appliance with a pilot light.

Never fill the tank until the fuel level rises into the filler neck. If the tank is filled until the fuel rises into the filler neck, heat from sunlight or other sources may cause the fuel to expand and overflow creating a fire hazard.

After refuelling, make sure the tank cap is closed securely.

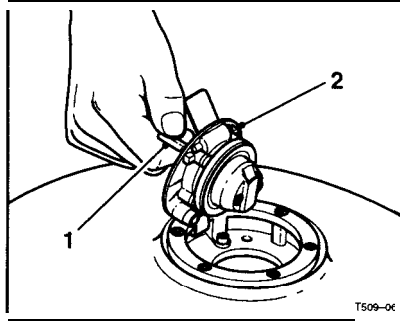

1. Ignition Switch Key
2. Fuel Tank Cap



WARNING: Take care not to spill any petrol (fuel) on the engine, exhaust pipes, tyres or any other part of the motorcycle.

If petrol (fuel) is spilled, thoroughly wipe off the spilled fuel immediately

FUEL TANK CAP

To open the fuel tank cap, lift up the key hole cover. Insert the key into the lock and turn the key clockwise.

To close and lock the cap, push the cap down into place, with the key inserted, until the lock 'clicks' into place. Withdraw the key.



CAUTION: Closing the cap without the key inserted will damage the cap, tank and lock mechanism.

General Information

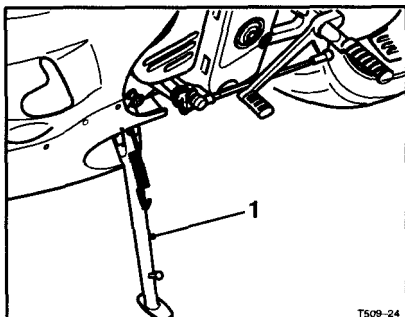

1. Side Stand

STAND

The motorcycle is equipped with a side stand on which the motorcycle can be parked.

NOTE:

- When using the side stand, always turn the handlebar to the left.
- Whenever the side stand is used, make it a practice to ensure that the stand is fully up after first sitting on the motorcycle.

TOOL KIT

The tool kit is strapped into a recess beneath the rear seat/rear cover.

HANDBOOK STORAGE

To gain access to the handbook, remove the seat.

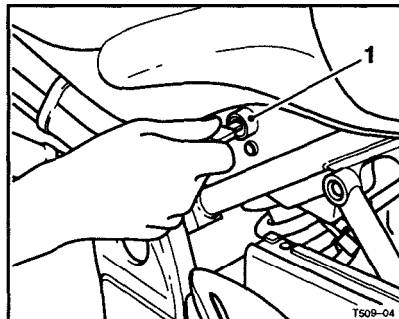

1. Seat Lock

SEAT LOCK OPERATION/ SEAT REMOVAL

The seat lock is situated on the left hand side of the battery box, in line with the footrest mounting rail, on the left hand side of the motorcycle.

The seat is removed in two sections. The rear seat (or rear cover, where fitted) is retained by the seat lock. The front seat is held in place by two threaded fixings.

To remove the rear seat/rear cover, insert the ignition key into the seat lock and turn the key anti-clockwise while pressing down on the rear part of the rear seat/rear cover.

To detach the seat/rear cover, lift the rear of the seat cover and slide it away from the front seat.

To refit the seat cover, engage the front section of the rear seat/rear cover under the seat bracket and press down on the rear to engage in the seat lock.

NOTE:

- An audible 'click' can be heard when the seat/seat cover is correctly engaged in the lock.

General Information

RUNNING-IN

The first 1000 miles (1600km) that the motorcycle is ridden is designated the 'running-in' period.

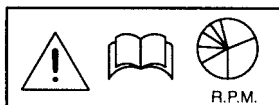

- The table below shows maximum recommended engine speeds during 'running-in'.
- These maximum speeds must be strictly adhered to during this period.

Distance Travelled	Maximum Engine Speed
0-100 miles (0-160km)	3500 rpm (r/min)
100-300 miles (160-480km)	5000 rpm (r/min)
300-600 miles (480-960km)	6000 rpm (r/min)
600-800 miles (960-1280km)	7000 rpm (r/min)
800-1 000 miles (1280-1 600km)	8000 rpm (r/min)

- Do not ride away or race the engine immediately after starting. Run the engine at idle for a short period of time to allow the oil to circulate to all parts of the engine.
- Do not race the engine while the transmission is in neutral.
- Do not use full throttle.
- Avoid riding continuously at one speed, vary the speed of the motorcycle from time to time.
- Regularly check that the coolant temperature gauge does not indicate that the engine is overheating. Stop immediately if overheating is indicated and allow the engine to cool.
- Do not allow the engine to 'labour' in any gear.

General Information

SAFE OPERATION

Daily Safety Checks

Check the following items each day before you ride. The time required is minimal, and these checks will help ensure a safe, reliable ride.

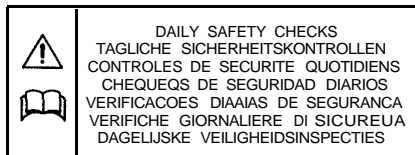

If any irregularities are found during these checks, refer to the Maintenance and Adjustment section or see your authorised Triumph dealer for the action required to return the motorcycle to a safe operating condition.

A **WARNING:** Failure to perform these checks every day before you ride may result in serious motorcycle damage or an accident causing serious injury or death.

Check:-

- * **Fuel** Adequate supply in tank, no fuel leaks (Page 22).
- **Engine oil** Correct level on sight glass. Add correct specification oil as required (Page 41).
- **Tyres/Wheels** Correct inflation pressures (when cold) (Page 58).
Tread depth/wear (min 2.0 mm tread depth), tyre/wheel damage, punctures etc.
- **Drive chain** Check drive chain for correct adjustment (Page 48).
- Nuts, bolts, **fasteners** Check that steering and suspension components, axles, and all controls are properly tightened or fastened. Visually inspect all areas for loose/damaged fixings.
- **Steering** Action smooth but not loose from lock to lock. No binding of any of the control cables (Page 53).
- **Brakes** Brake pad wear: There should be more than 1.5 mm lining remaining. No brake fluid leakage. Brake fluid levels must be between max and min (Page 51).
- **Front Forks** Smooth action. No fork oil leakage (Page 54).
- **Throttle** Throttle grip play 2-3 mm. Ensure that the throttle grip returns to the idle position without sticking (Page 46).
- **Clutch** Smooth operation and correct cable free-play (Page 47).

General Information

- . **Coolant** No coolant leakage. Check the coolant level in the expansion tank (when the engine is cold) (Page 45).
- . **Electrical equipment** All lights and horn function correctly (Page 21).
- . **Engine stop** Stop switch turns the engine off (Page 20).
- . **Sidestand** Returns to the fully up position by spring tension. Return springs not weak or damaged (Page 23).
- **Battery** Check electrolyte level. Add distilled water as necessary (Page 62).

How to Ride the Motorcycle

Contents

To Stop the Engine	28
To Start The Engine	28
Moving Off	29
Changing Gears	29
Braking	30
Parking	32
Considerations For High Speed Operation	33

How to Ride the Motorcycle

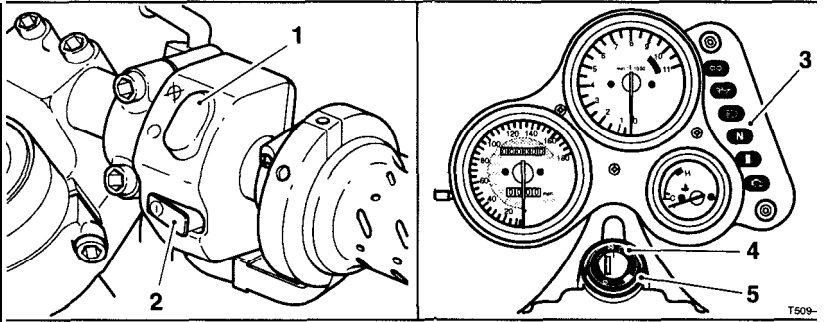

1. Engine Stop Switch
2. Starter Button
3. Neutral Indicator Light
4. On Position
5. Ignition Switch

TO STOP THE ENGINE

- Close the throttle completely.
- Select neutral.
- Turn the ignition switch off.
- Support the motorcycle on a firm, level surface with the side stand.
- Lock the steering.



CAUTION: The engine should normally be stopped by turning the ignition switch off. The engine stop switch is for emergency use only.

Do not leave the ignition switched on with the engine stopped. Electrical damage may result.

TO START THE ENGINE

- Check that the engine stop switch is in the run position.
- Ensure that the transmission is in neutral.
- Pull the clutch lever fully in to the handlebar.
- Turn the ignition switch on.
- Leaving the throttle completely closed, push the starter button until the engine starts.

NOTE:

- In very cold conditions, part open the throttle to aid starting. Return throttle to the closed position once the engine has started.



WARNING: Never start the engine or run the engine in a confined area. Exhaust fumes are poisonous and can rapidly cause loss of consciousness and death within a short time.

Always operate your motorcycle in the open-air or in an area with adequate ventilation.

How to Ride the Motorcycle



CAUTION: Do not operate the starter continuously for more than 5 seconds as the starter motor will overheat and battery power will drop. Wait 15 seconds between each operation of the starter to allow for cooling and recovery of battery power.

Do not let the engine idle for long periods as this may lead to overheating which will cause damage to the engine.

NOTE:

- If the engine is flooded, crank the engine over, with the throttle fully open.
- The motorcycle is equipped with starter lockout switches. The switches prevent the electric starter from operating when the clutch is engaged and the transmission is not in neutral.



CAUTION: The low oil pressure warning light should go out as soon as the engine starts.

If the low oil pressure warning light stays on after starting the engine, stop the engine immediately and investigate the cause.

Running the engine with low oil pressure will cause severe engine damage.

MOVING OFF

- Pull in the clutch lever and select first gear. Open the throttle slightly and let out the clutch lever slowly. As the clutch starts to engage, open the throttle a little more, allowing enough engine speed to avoid stalling.

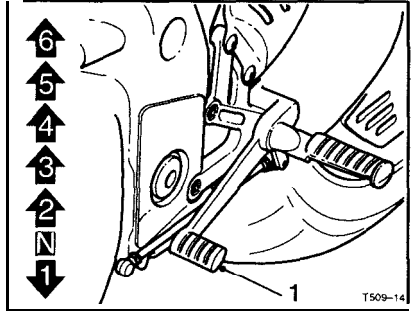

1. Gear Change Pedal

CHANGING GEARS

- Close the throttle while pulling in the clutch lever. Change into the next higher or lower gear. Open the throttle part way, while releasing the clutch lever. Always use the clutch when changing gear.

NOTE:

- The gear change mechanism is the 'positive stop' type. This means that, for each movement of the gear change pedal, you can only select each gear, one after the other, in ascending or descending order.



WARNING: Do not change to a lower gear at speeds which will cause excessive engine rpm (r/min). This can lock the rear wheel causing loss of control and an accident. Engine damage may also be caused. Changing down should be done below 5000 rpm (r/min) for each gear.

How to Ride the Motorcycle

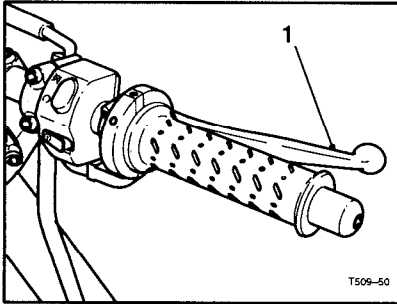

1. Front Brake Lever

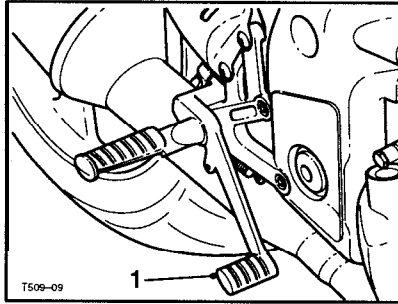

1. Rear Brake Pedal

BRAKING

A **WARNING: WHEN BRAKING. OBSERVE THE FOLLOWING:**

Close the throttle completely, leaving the clutch engaged to allow the engine to help slow down the motorcycle.

Change down one gear at a time such that the transmission is in first gear when the motorcycle comes to a complete stop.

When stopping, always apply both brakes at the same time. Normally the front brake should be applied a little more than the rear.

Change down or fully disengage the clutch as necessary to keep the engine from stalling.

Never lock the brakes, as this may cause loss of control of the motorcycle and an accident.

A **WARNING:** For emergency braking, disregard down changing, and concentrate on applying the front and rear brakes as hard as possible without skidding. Riders should practice emergency braking in a traffic-free area.

Triumph strongly recommend that all riders take a course of instruction which includes advice on safe brake operation. Incorrect brake technique could result in loss of control and an accident.

How to Ride the Motorcycle

A WARNING: For your safety, always exercise extreme caution when braking, accelerating or turning as any incautious action can cause loss of control and an accident. Independent use of the front or rear brakes reduces overall braking performance. Extreme braking may cause either wheel to lock, reducing control of the motorcycle and causing an accident.

When possible, reduce speed or brake before entering a turn as closing the throttle or braking in mid-turn may cause wheel slip leading to loss of control and an accident.

When riding in wet or rainy conditions, or on loose surfaces, the ability to manoeuvre and stop will be reduced. All of your actions should be smooth under these conditions. Sudden acceleration, braking or turning may cause loss of control and an accident.

A WARNING: When descending a long, steep gradient use engine braking by down-changing and use the brakes intermittently. Continuous brake application can overheat the brakes and reduce their effectiveness.

Riding with your foot on the brake pedal or your hands on the brake lever may actuate the brake light, giving a false indication to other drivers. It may also overheat the brake, reducing braking effectiveness.

Do not coast with the engine switched off, and do not tow the motorcycle. The transmission is pressure-lubricated only when the engine is running. Inadequate lubrication may cause damage or seizure of the transmission which can lead to sudden loss of motorcycle control and an accident.

How to Ride the Motorcycle

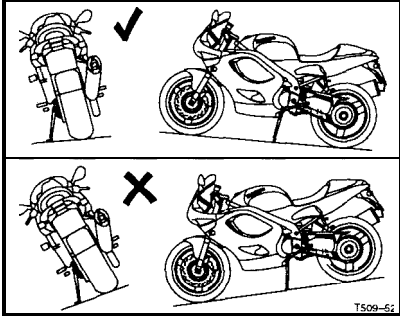

PARKING

Select neutral and turn the ignition switch to the 'OFF' position.

Always park on a firm, level surface to prevent the motorcycle from falling.

When parking on a hill, always park facing uphill to prevent the motorcycle from rolling off the stand.

On a lateral (sideways) incline, always park with the motorcycle leaning towards the sidestand and engage first gear to prevent the motorcycle from moving.

Do not park on a lateral (sideways) incline of greater than 6" and never park facing downhill.

Lock the steering to help prevent theft.

NOTE:

- When parking near traffic at night, leave the tail, licence plate and side lights on by turning the ignition switch to P (Park).
- Do not leave the switch in the 'P' position for long periods as this will discharge the battery.

A **WARNING:** Do not park on a soft or on a steeply inclined surface as parking under these conditions may cause the motorcycle to fall over. Ensure that the stand is fully retracted before riding off.

Petrol is extremely flammable and can be explosive under certain conditions. If parking inside a garage or other structure, be sure it is well ventilated and the motorcycle is not close to any source of flame or sparks. This includes any appliance with a pilot light.

The engine and exhaust system will be hot after riding. **DO NOT** park where pedestrians and children are likely to touch the motorcycle as touching any of the hot parts may cause unprotected skin to become burnt.

How to Ride the Motorcycle

CONSIDERATIONS FOR HIGH SPEED OPERATION

A WARNING: This Triumph motorcycle should be operated within the legal speed limits for the particular road travelled. Operating a motorcycle at high speeds can be potentially dangerous since the time available to react to given traffic situations is greatly reduced as road speed increases. Always reduce speed in consideration of weather and traffic conditions. Only operate this Triumph motorcycle at high speed in closed-course on-road competition or on closed course race tracks.

A WARNING: The items listed are extremely important and must never be neglected. A problem which may not be noticed at normal operating speeds may be greatly exaggerated at high speeds.

A WARNING: The handling characteristics of a motorcycle at high speed may vary from those you are familiar with at legal road speeds. Do not attempt high speed operation unless you have received sufficient training and have the required skills as a serious accident may result from incorrect operation.

Brakes

Check that the front and rear brakes are functioning properly.

Steering

Check that the handlebar turns smoothly without excessive free play or tight spots, Ensure that the control cables do not restrict the steering in any way.

Tyres

High speed operation is hard on tyres, and good tyres are crucial for riding safely. Examine their overall condition, inflate to the correct pressure (when the tyres are cold), and check the wheel balance. Securely fit the valve caps after checking tyre pressures. Observe the information given in maintenance and specification sections on tyre checking and tyre safety.

Fuel

Have sufficient fuel for the higher consumption experienced during high speed operation.

Engine Oil

Make certain that the oil level is visible mid-way up the sight glass. Ensure that the correct grade and type of oil is used when topping-up.

Coolant

Check that the coolant level is at the upper level line in the expansion tank. (Always check level with engine cold).

Electrical Equipment

Make certain that the headlight, rear/brake light, turn signals, horn etc., all work properly.

Miscellaneous

Make certain that all fixings are tight and that all safety related parts are in good condition.

Accessories, Loading and Passengers

The addition of accessories and carriage of additional weight can affect the motorcycle's handling characteristics causing changes in stability and necessitating a reduction in speed. The following information has been prepared as a guide to the potential hazards of adding accessories to a motorcycle and carrying passengers and additional loads,

A **WARNING:** Incorrect loading may result in an unsafe riding condition leading to an accident.

Always ensure any loads carried are evenly distributed on both sides of the motorcycle. Ensure that the load is correctly secured such that it will not move around while the motorcycle is in motion.

Always check the load security regularly (though not while the motorcycle is in motion) and ensure that the load does not extend beyond the rear of the motorcycle.

Never exceed the maximum vehicle loading weight of 185 Kg (407 lbs).

This maximum weight is made up from the combined weight of the rider, passenger and any load carried.

A **WARNING:** Do not install accessories or carry luggage that impairs the control of the motorcycle. Make sure that you have not adversely affected any lighting component, road clearance, banking capability (i.e. lean angle), control operation, wheel travel, front fork movement, or any other aspect of the motorcycle's operation.

A **WARNING:** Never ride an accessory equipped motorcycle at speeds above 130km/h (80mph).

The presence of accessories will cause changes in the stability and handling of the motorcycle.

Failure to allow for changes in motorcycle stability may lead to loss of control or an accident.

Remember that the 130km/h (80mph) limit will be reduced by the fitting of non-approved accessories, incorrect loading, worn tyres, overall motorcycle condition and poor road or weather conditions.

! **WARNING:** This motorcycle must not be operated above the legal road speed limit except in authorised 'closed' course conditions.

A **WARNING:** The handling and braking capabilities of a motorcycle will be affected by the presence of a passenger. The rider must make allowances for these changes when operating the motorcycle with a passenger.

Motorcycle operation without making allowances for the presence of a passenger could lead to loss of motorcycle control and an accident.

Accessories, Loading and Passengers

A WARNING: Single seat models must never carry a passenger unless a passenger seat is fitted. Carrying a passenger without first fitting a passenger seat will contravene the law and may also cause loss of motorcycle control leading to an accident.

A WARNING: Your passenger should be thoroughly familiar with motorcycle operation.

The passenger can cause loss of control of the motorcycle by incorrect positioning during cornering and sudden movements.

It is important that the passenger sits still while the motorcycle is in motion and does not interfere with the operation of the motorcycle.

If a passenger is carried, the rider should instruct the passenger to keep his or her feet on the passenger footrests and to firmly hold onto the seat strap or the rider's waist or hips.

The passenger should also be advised to lean with the rider when travelling in corners and not to lean unless the rider does so.

Do not carry animals on your motorcycle.

A WARNING: Do not carry a passenger unless he or she is tall enough to reach the footrests provided.

A passenger who is not tall enough to reach the footrests will be unable to sit securely on the motorcycle and may cause instability leading to loss of control and an accident.

A WARNING: Never attempt to store any items between the frame and the fairing. This can restrict the steering and will cause loss of control leading to an accident.

Weight attached to the handlebar or front fork will increase the mass of the steering assembly and can result in loss of steering control leading to an accident.

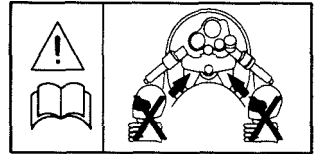

Maintenance and Adjustment

100% Synthetic*

Mobil 1
racing 4T



Specially filled for
TRIUMPH

Your Triumph Motorcycle is a quality engineered product which has been carefully built and tested to exacting standards. Triumph Motorcycles are keen to ensure that you enjoy optimum performance from your machine and with this objective in mind have tested many of the engine lubricants currently available to the limits of their performance.

Mobil 1 Racing 4T consistently performed well during our tests and has become our primary recommendation for the lubrication of all current Triumph motorcycle engines.

Mobil 1 Racing 4T, specially filled for Triumph, is available from your authorised Triumph dealer.

Maintenance and Adjustment

Contents

Scheduled Maintenance	38
Side Panel ,	40
Engine Oil...	41
Cooling System...	44
Throttle Grip...	46
Clutch...	47
Drive Chain...	48
Brakes	51
Steering/Wheel Bearings ...	53
Front Suspension	54
Rear Suspension Adjustment	57
Tyres	58
Battery.....	62
Windscreen Cleaning	64
Fuses	65
Headlights - Daytona	66
Headlights - Speed Triple	68
Rear Light	70
Licence Plate Light	70
Indicator Light	70
Cleaning	71

Maintenance and Adjustment

SCHEDULED MAINTENANCE

To maintain the motorcycle in a safe and reliable condition, the maintenance and adjustments outlined in this section must be carried out as specified in the schedule of daily checks, and also in line with the scheduled maintenance chart. The information which follows describes the procedures to follow when carrying out the daily checks and some simple maintenance and adjustment items.

A WARNING: In order to correctly carry out the maintenance items listed in the scheduled maintenance chart, special tools and specialist knowledge will be required. Only an authorised Triumph dealer will have this knowledge and equipment.

Since incorrect or neglected maintenance can lead to a dangerous riding condition, always have an authorised Triumph dealer carry out the scheduled maintenance of this motorcycle.

Scheduled Maintenance Chart

Operation Description	Odometer Reading in Miles (Kms)						
	Every	500 (800)	6000 (1 0 0 0 0)	12000 (0 0)	16000 (20000) (30000)	24000 (40000)	30000 (50000)
Engine oil – renew		●	●	●	●	●	●
Engine oil filter – renew	–	●	●	●	●	●	●
Valve clearances – check/adjust	–			●		●	
Air cleaner element – renew	–			●		●	
Engine ECM – check for stored DTCs	–	●	●	●	●	●	●
Spark plugs – check	–			●			
Spark plugs – renew	–					●	
Throttle bodies – balance	–			●		●	
Throttle cable – check/adjust	Day	●	●	●	●	●	●
Coolant level – check/adjust	Day	●	●	●	●	●	●
Coolant – renew		Every Two Years					
Cooling system -check for leaks	Day	●	●	●	●	●	●
Fuel system -check for leaks	Day	●	●	●	●	●	●
Fuel Filter – renew				●		●	
Steering – check for free operation	Day	●	●	●	●	●	●

Maintenance and Adjustment

Scheduled Maintenance Chart (Continued)							
Operation Description	Odometer Reading in Miles (Kms)						
	Every	500 (800)	6000 (10000)	12000 (20000)	18000 (30000)	24000 (40000)	30000 (50000)
Headstock bearing -check/adjust	-			●		●	
Headstock bearing - lubricate	-			●		●	
Forks-check for leaks/smooth operation	Day	●	●	●	●	●	●
Fork oil - renew				●		●	
Brake fluid levels-check	Day	●	●	●	●	●	●
Brake fluid - renew	Every 2 years						
Brake hoses -renew	Every 4 years						
Brake light-check operation	Day	●	●●	●●	●●	●●	●●
Brake pads - check wear levels	Day	●	●	●	●	●	●
Brake master cylinder - renew seals	Every 2 years						
Brake calipers - renew seals	Every 2 years						
Drive chain - lubricate	Every 200 miles (300 kms)						
Drive chain -wear check	Every 500 miles (800 kms)						
Drive chain slack - check/adjust	Day	●	●	●●	●	●●	●
Rear suspension - lubricate	3 years/24000 miles (40000 kms)						
Fasteners - inspect visually for security	Day	●	●	●	●	●	●
Wheels - inspect for damage	Day	●	●	●	●	●	●
Tyre wear/tyre damage - check	Day	●	●	●	●	●	●
Tyre pressures - check/adjust	Day	●	●	●	●	●	●
Battery electrolyte level - check/adjust	Day	●	●	●	●	●	●
Clutch cable - check/adjust	Day	●	●	●	●	●	●

Maintenance and Adjustment

A **WARNING:** All maintenance is vitally important and must not be neglected. Incorrect maintenance or adjustment may cause one or more parts of the motorcycle to malfunction. A malfunctioning motorcycle is dangerous and may lead to an accident.

Weather, terrain and geographical location affects maintenance. The maintenance schedule should be adjusted to match the particular environment in which the vehicle is used and the demands of the individual owner.

Triumph Motorcycles cannot accept any responsibility for damage or injury resulting from incorrect maintenance or improper adjustment carried out by the owner.

Since incorrect or neglected maintenance can lead to a dangerous riding condition, always have an authorised Triumph dealer carry out the scheduled maintenance of this motorcycle.

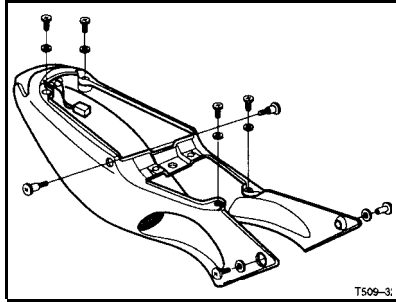

SIDE PANEL

Side Panel Removal

- Remove the seat(s).
- Disconnect the battery, negative (black) lead first.
- Release the fixings as shown in the diagram above.
- Disconnect the rear light.
- Lift and withdraw the side panel assembly in a rearward direction.

Side Panel Refitting

- Reverse the removal procedure with the exception of the following.
- Reconnect the battery positive (red) lead first.
- Tighten the panel fixings to 9 Nm.

Maintenance and Adjustment

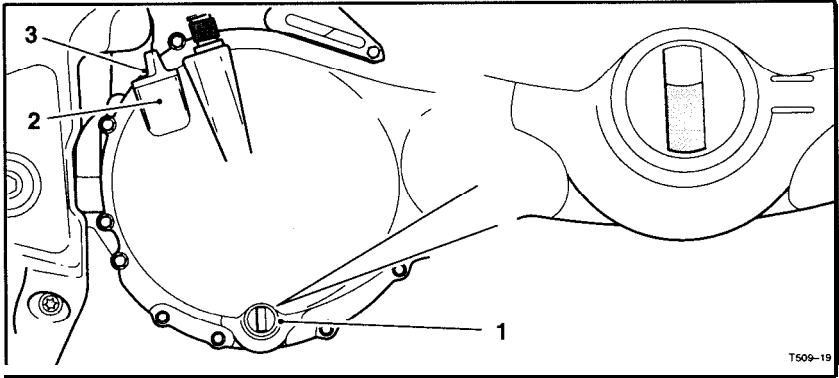

1. Sight Glass
2. Filler
3. Filler Plug

ENGINE OIL



In order for the engine, transmission, and clutch to function correctly, maintain the engine oil at the correct level, and change the oil and oil filter in accordance with scheduled maintenance requirements.

A **WARNING:** Motorcycle operation with insufficient, deteriorated, or contaminated engine oil will cause accelerated engine wear and may result in engine or transmission seizure. Seizure of the engine or transmission may lead to loss of control and an accident.

Oil Level Inspection

- Stop engine, then wait for at least 10 minutes to allow the oil to settle.
- The oil level is indicated by a sight glass situated at the bottom of the clutch cover on the right hand side of the motorcycle. When the oil level is correct, the level of oil should be between the two lines marked on the sight glass.

NOTE:

- **The actual level is indicated when the motorcycle is level and upright, not on the side stand.**
- If the oil level is too low, remove the plug situated in the upper rear side of the clutch cover.
- Add oil, a little at a time, until the oil begins to show in the sight glass. Then adjust to the correct level and refit the plug.

Maintenance and Adjustment

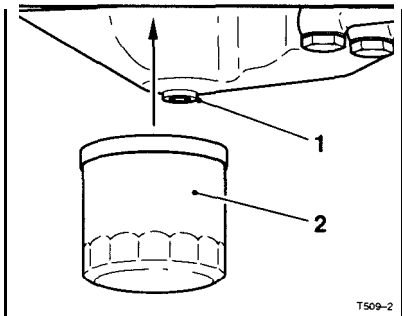

1. Oil Drain Plug
2. Oil Filter

Oil and Oil Filter Change

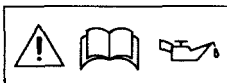

A **WARNING:** Prolonged or repeated contact with engine oil can lead to skin dryness, irritation and dermatitis. In addition, used engine oil contains potentially harmful contamination which can cause cancer. Wear suitable clothing and avoid skin contact.

- With the motorcycle on level ground, allow the oil to completely drain.
- Unscrew and remove the oil filter using the Triumph service tool T3880310.
- Discard the oil filter.
- Apply a smear of clean engine oil to the sealing ring of the new oil filter.
- Fit the oil filter and tighten to 12 Nm.
- After the oil has completely drained out, fit a new sealing washer to the engine drain plug. Fit and tighten the plug to 25 Nm.
- Fill the engine with new oil of the type and grade listed in the specification section.
- Start the engine and allow to idle.

! **CAUTION:** Racing the engine before the oil reaches every part can cause engine damage or seizure.

The engine oil and filter must be replaced in accordance with scheduled maintenance requirements.

- Warm up the engine thoroughly, and then stop the engine.
- Place an oil pan beneath the engine.
- Remove the engine drain plug.

! **WARNING:** The oil may be hot to the touch. Contact with hot oil may cause the skin to be scalded or burned.

Maintenance and Adjustment

- Ensure that the oil pressure warning light extinguishes shortly after starting.



CAUTION: If the engine oil pressure is too low, the low oil pressure warning light will illuminate. If this light stays on when the engine is running, stop the engine immediately and investigate the cause. Running the engine with low oil pressure will cause engine damage.

- Stop the engine and check the oil level. Adjust if necessary.

Disposal of Used Engine Oil

To protect the environment, do not pour oil on the ground, down sewers or drains, or into water courses. Dispose of used oil sensibly. If in doubt contact your local authority.



CAUTION: Triumph high performance fuel injected engines are designed to use semi or fully synthetic 10W/40 motorcycle engine oil which meets specification API SH.

Do not add any chemical additives to the engine oil. The engine oil also lubricates the clutch and any additives could cause the clutch to slip.

Do not use mineral, vegetable, non-detergent oil, castor based oils or any oil not conforming to the required specification. The use of these oils may cause instant, severe engine damage.

Ensure no foreign matter enters the crankcase during an oil change or top-up.

Maintenance and Adjustment

COOLING SYSTEM



To ensure efficient engine cooling, check the coolant level each day before riding the motorcycle, and top up the coolant if the level is low.

Corrosion Inhibitors

To protect the cooling system from rust and corrosion, the use of corrosion inhibitor chemicals in the coolant is essential.

If coolant containing corrosion and rust inhibitor chemicals is not used, the cooling system will accumulate rust and scale in the water jacket and radiator. This will block the coolant passages, and considerably reduce the efficiency of the cooling system.

A **WARNING:** Use coolant mixture containing corrosion inhibitors and anti-freeze suitable for aluminium engines and radiators. Always use the anti-freeze in accordance with the instructions of the manufacturer.

Coolant mixture which contains anti-freeze and corrosion inhibitors contains toxic chemicals which are harmful to the human body. Never swallow anti-freeze or any of the motorcycle coolant.

Coolant Change

Have the coolant changed by an authorised Triumph dealer in accordance with scheduled maintenance requirements.

Radiator Hoses

Check the radiator hoses for cracks or deterioration, and hose clips for tightness in accordance with scheduled maintenance requirements. Have your authorised Triumph dealer replace any defective items.



CAUTION: A permanent type of antifreeze is installed in the cooling system when the motorcycle leaves the factory. It is coloured blue, contains a 50% solution of ethylene glycol, and has a freezing point of -35°C (-31°F)

Radiator and Cooling Fan

Check the radiator fins for obstructions by insects, leaves or mud. Clean off any obstructions with a stream of low-pressure water.



WARNING: The cooling fan operates automatically, even with the ignition switch off. Always keep hands and clothing away from the fan. Contact with the rotating fan can cause injury.



CAUTION: Using high pressure water, such as from a car wash facility, can damage the radiator fins and impair the radiator's efficiency.

Do not obstruct or deflect airflow through the radiator by installing unauthorised accessories, either in front of the radiator or behind the cooling fan. Interference with the radiator airflow can cause overheating, resulting in engine damage.

Maintenance and Adjustment

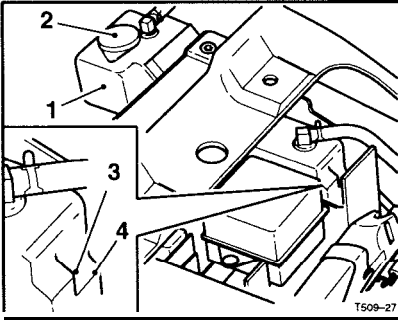

1. Expansion Tank
2. Tank Cap
3. 'MAX' Mark
4. 'MIN' Mark

Coolant Level Inspection

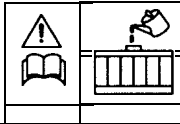

A **WARNING:** Do not remove the radiator cap when the engine is hot. When the engine is hot, the coolant inside the radiator is hot and also under pressure. Contact with this hot, pressurised coolant will cause scalds and skin damage.

NOTE

- If the coolant level is being checked because the coolant has overheated, also check the level in the radiator and top-up if necessary.
- In an emergency, water alone can be added to the cooling system. However, the coolant must be returned to the correct mixture ratio as soon as possible.

CAUTION: Distilled water must be used with the antifreeze (see specification for antifreeze) in the cooling system.

If hard water is used in the system, it causes scale accumulation in the water passages, and considerably reduces the efficiency of the cooling system.

If coolant must be added often, or the expansion tank runs dry, there is probably a leak in the system. Have the cooling system inspected by your authorised Triumph dealer.

- Position the motorcycle on level ground and in an upright position.
- Remove the seat.
- Check the coolant level in the expansion tank. The coolant level must be between the 'MAX' and 'MIN' marks.
- If the level of coolant is too low, remove the cap from the expansion tank, and add coolant mixture through the filler opening to the 'MAX' mark. Refit the cap.

Maintenance and Adjustment

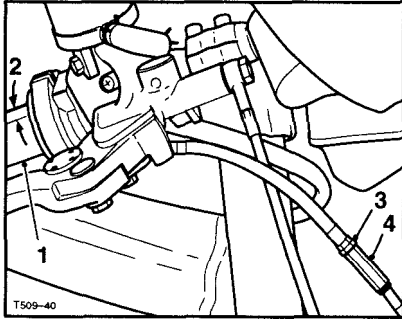

1. Throttle Grip
2. 2-3mm
3. Upper Adjuster Locknut
4. Adjuster

THROTTLE GRIP

The throttle grip controls the throttle valves in the throttle bodies.

If the throttle cable is incorrectly adjusted, either too tight or too loose, the throttle may be difficult to control and performance will be adversely affected.

Check the throttle grip free-play in accordance with scheduled maintenance requirements and make adjustments as necessary.

Inspection

- Check that there is 2-3 mm throttle grip free-play when lightly turning the throttle grip back and forth.
- If there is an incorrect amount of free-play, adjustments must be made.

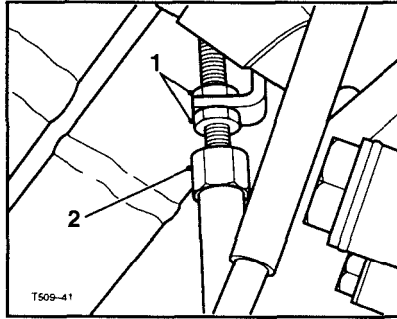

1. Locknut
2. Adjuster (Throttle Body End)



WARNING: Use of the motorcycle with an incorrectly adjusted, incorrectly routed, sticking or damaged throttle cable could interfere with the throttle function resulting in loss of control of the motorcycle and an accident.

Adjustment

NOTE:

- Minor adjustments can be made using the adjuster near the twist grip end of the throttle. Where a correct setting cannot be achieved in this way, the adjuster at the throttle body end must be used.
- Disconnect the battery negative (black) lead first.
- Set the cable adjuster at the twist grip end such that it has an equal amount of adjustment in each direction.

Maintenance and Adjustment

- Set the adjuster at the throttle body end of the cable to give 2-3 mm of play at the twist grip. Tighten the locknut.
- Make any minor adjustments as necessary to give 2-3 mm of play using the adjuster at the twist grip end of the cable. Tighten the locknut.

A **WARNING:** Ensure that both the adjuster locknuts are tightened. A loose throttle cable adjuster could cause the throttle to stick leading to loss of control and an accident.

- Reconnect the battery, positive (red) lead first.
- Refit the seat.

CLUTCH

The motorcycle is equipped with a cable operated clutch.

If the clutch lever has excessive free-play, the clutch may not disengage fully and cause difficulty in changing gear and clutch drag. Conversely, if the clutch lever has insufficient free-play the clutch may not engage fully, causing clutch slip.

Clutch lever free-play must be checked in accordance with scheduled maintenance requirements.

Inspection

- Check that there is 0.4-0.8 mm clutch lever free-play as shown in the diagram above.
- If there is an incorrect amount of free-play, adjustments must be made.

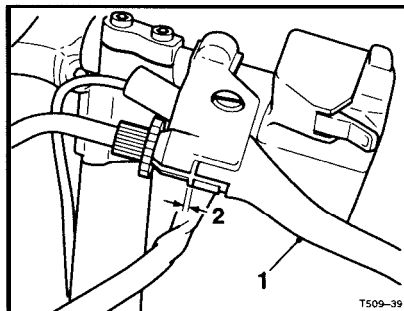

1. Lever
2. 0.4-0.8 mm

Adjustment

- Loosen the knurled locknut at the lever end of the clutch cable and turn the adjuster sleeve until the correct amount of clutch lever free-play is achieved.
- Tighten the knurled locknut against the clutch lever assembly.
- If correct adjustment cannot be made using the lever adjuster, use the cable adjuster at the lower end of the cable.
- Loosen the adjuster locknut.
- Turn the outer cable adjuster to give 0.4-0.8 mm of free-play at the clutch lever.
- Tighten the locknut.

Maintenance and Adjustment

DRIVE CHAIN

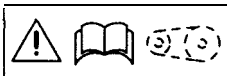

For safety and to prevent excessive wear, the drive chain must be checked, adjusted, and lubricated in accordance with scheduled maintenance requirements. Checking, adjustment and lubrication must be carried out more frequently for extreme conditions such as salty or heavily gritted roads.

If the chain is badly worn or incorrectly adjusted (either too loose or too tight) the chain could jump off the sprockets or break.

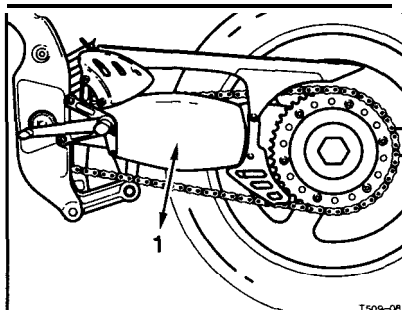

1. Maximum Movement Position (35-40 mm)

Chain Free-movement Adjustment

- If the chain free-movement measurement is incorrect, adjustments must be made as follows:
- Loosen the clamp bolt which secures the rear hub/eccentric adjuster to the swinging arm.
- Using the 'C' spanner supplied in the motorcycle tool kit, turn the rear hub/eccentric adjuster (clockwise to loosen, anti-clockwise to tighten) until the drive chain is correctly adjusted (35-40 mm of vertical movement).
- Tighten the rear hub/eccentric adjuster clamp bolt to 55 Nm.
- Rotate the rear wheel and repeat the chain adjustment check. Re-adjust if outside the 35-40 mm limit.

WARNING: A chain that breaks or jumps off the sprockets could snag on the engine sprocket or lock the rear wheel, severely damaging the motorcycle and causing an accident. Never neglect chain maintenance.

NOTE:

- Checking, adjustment and lubrication of the drive chain must be carried out with the motorcycle set up on a paddock stand so that the rear suspension hangs free.

Chain Free-movement Inspection

A WARNING: To prevent risk of injury from the motorcycle falling during the inspection, ensure that the motorcycle is stabilized and secured on the stand.

- Rotate the rear wheel to find the position where the chain is tightest, and measure the vertical movement of the chain midway between the sprockets.
- The vertical movement of the drive chain must be 35-40 mm.

Maintenance and Adjustment

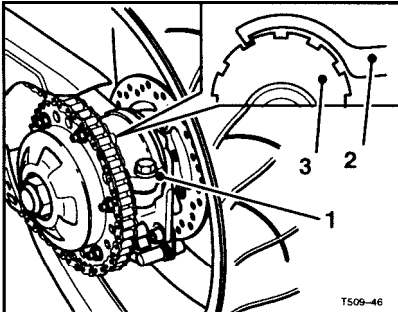

1. Adjuster Clamp Bolt
2. 'C' Spanner
3. Eccentric Adjuster

A **WARNING:** Operation of the motorcycle with an insecure rear hub/eccentric adjuster clamp bolt may result in impaired stability and handling of the motorcycle. This impaired stability and handling may lead to loss of control or an accident.

- Check the rear brake effectiveness.

Chain Wear Inspection

A **WARNING:** To prevent risk of injury from the motorcycle falling during inspection, ensure that the motorcycle is stabilized and secured on the paddock stand.

- Remove the chain guards.

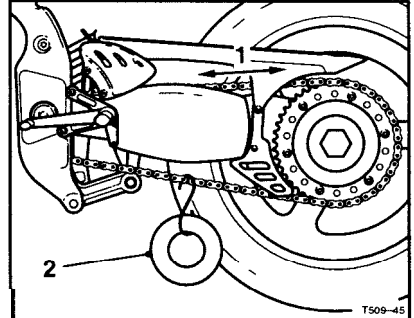

1. Measure Across 20 Links
2. Weight

- Stretch the chain taut by hanging a 10-20 kg (20-40 lb) weight on the chain.
- Measure the length of 20 links on the straight part of the chain from pin centre of the 1 st pin to the centre of the 21st pin. Since the chain may wear unevenly, take measurements at several places.
- If the length exceeds the maximum service limit of 319 mm, the chain must be replaced.

A **WARNING:** A chain that breaks or jumps off the sprockets could snag on the engine sprocket or lock the rear wheel, severely damaging the motorcycle and causing loss of control and an accident.

Maintenance and Adjustment

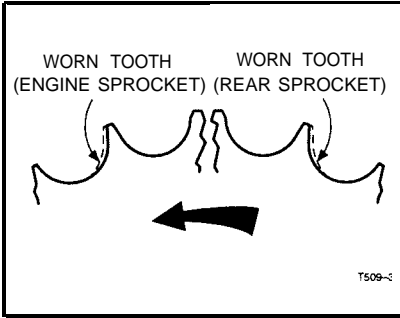

NOTE:

- Sprocket wear is exaggerated for illustration.

WARNING: The use of non-approved chains may result in a broken chain or may cause the chain to jump off the sprockets.

Use a genuine Triumph supplied chain as specified in the Triumph Parts Catalogue.

Never neglect chain maintenance and always have chains installed by an authorised Triumph dealer.

- Rotate the rear wheel and inspect the drive chain for damaged rollers, and loose pins and links.
- Also inspect the sprockets for unevenly or excessively worn or damaged teeth.

- If there is any irregularity, have the drive chain and/or the sprockets replaced by an authorised Triumph dealer.

- Replace the chain guard.

Chain Lubrication



Lubrication is necessary every 500 miles and also after riding in wet weather, on wet roads, or any time that the chain appears dry.

Use the special chain lubricant as recommended in the specification section.

- Apply lubricant to the sides of the rollers. This will allow the oil to penetrate to the chain rollers and bushings. Also apply oil to the chain 'O' rings. Wipe off any excess oil.
- If the chain is especially dirty, clean first using paraffin and then apply oil as mentioned above.



CAUTION: Do not use a power 'jet' wash to clean the chain as this may cause damage to the chain components.

Maintenance and Adjustment

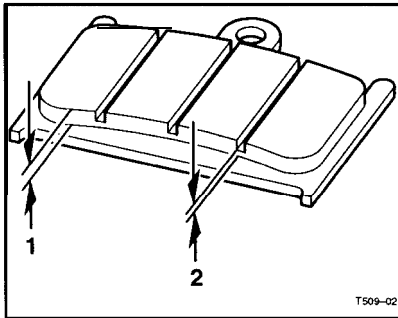

1. Lining Thickness
2. 1.5 mm (0.06 in) Groove Thickness

BRAKES

Brake Wear Inspection

Brake pads must be inspected in accordance with scheduled requirements and replaced if worn to, or beyond the minimum service thickness.

If the lining thickness of any pad (front or rear brakes) is less than 1.5 mm (0.06 in), that is, if the pad has worn down to the bottom of the grooves, replace all the pads on the wheel.

A WARNING: Brake pads must always be replaced as a wheel set. At the front, where two calipers are fitted on the same wheel, replace all the brake pads in both calipers.

Replacing individual pads will reduce braking efficiency and may cause an accident.

Disc Brake Fluid

Inspect the level of brake fluid in both reservoirs and change the brake fluid in accordance with scheduled maintenance requirements. Use only DOT 4 fluid as recommended in the specification section. The brake fluid must also be changed if it becomes, or is suspected of having become contaminated with moisture or any other contaminants.

A WARNING: Brake fluid is hygroscopic which means it will absorb moisture from the air.

Any absorbed moisture will greatly reduce the boiling point of the brake fluid causing a reduction in braking efficiency.

Because of this, always replace brake fluid in accordance with scheduled maintenance requirements.

Always use new brake fluid from a sealed container and never use fluid from an unsealed container or from one which has been previously opened.

Do not mix different brands or grades of brake fluid.

Check for fluid leakage around brake fittings, seals and joints and also check the brake hoses for splits, deterioration and damage.

Always rectify any faults before riding.

Failure to observe and act upon any of these items may cause a dangerous riding condition leading to loss of control and an accident.

Maintenance and Adjustment

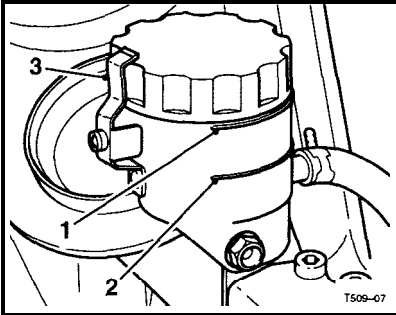

1. Upper Level, Front Brake
2. Lower Level, Front Brake
3. Safety Clip

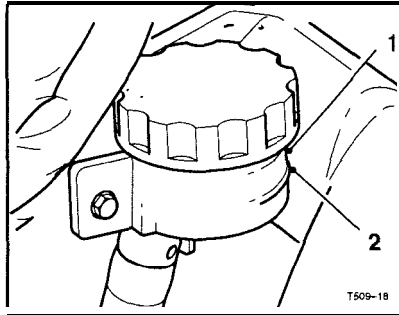

1. Upper Level, Rear Brake
2. Lower Level, Rear Brake

Brake Fluid Level Inspection and Adjustment

- The brake fluid level in the reservoirs must be kept between the upper and lower level lines (reservoir held horizontal).
- At the rear, remove the side panel assembly.
- Remove the safety clip (front only).
- Fill the reservoir to the upper level line using new DOT 4 fluid from a sealed container.
- Refit the reservoir cap ensuring that the diaphragm seal is correctly fitted.
- Refit the safety clip.
- At the rear, refit the side panels.

A **WARNING:** If there has been an appreciable drop in the level of the fluid in any fluid reservoir, consult your authorised Triumph dealer for advice before riding.

Riding with defective brakes may lead to an accident.

Brake Pad Wear Compensation

Disc and disc pad wear is automatically compensated for and has no effect on the brake lever or pedal action. There are no parts that require adjustment on the front and rear brakes.

A **WARNING:** If the brake lever or pedal feels soft when it is applied, or if the lever/pedal travel becomes excessive, there may be air in the brake lines or the brake may be defective.

It is dangerous to operate the motorcycle under such conditions and remedial action must be taken by your authorised Triumph dealer before riding.

Riding with defective brakes may lead to an accident.

Maintenance and Adjustment

Brake Light Switches

The brake light is activated independently by either the front or rear brake. If the brake light does not work when the front brake lever is pulled, or the rear brake pedal depressed, ask your authorised Triumph dealer to investigate and rectify the fault.

A WARNING: Riding the motorcycle with defective brake lights is illegal and dangerous.

An accident causing injury to the rider and other road users may result from use of a motorcycle with defective brake lights.

STEERING/WHEEL BEARINGS

Steering Inspection

Lubricate and inspect the condition of the headstock (steering) bearings in accordance with scheduled maintenance requirements.

NOTE

- Always inspect the wheel bearings at the same time as the steering bearings.

A WARNING: To prevent risk of injury from the motorcycle falling during the inspection, ensure that the motorcycle is stabilized and secured on the support block.

Do not exert extreme force against each wheel or rock each wheel vigorously as this may cause the motorcycle to become unstable or cause injury by falling from its support.

Ensure that the position of the support block will not cause damage to the oil lines beneath the sump.

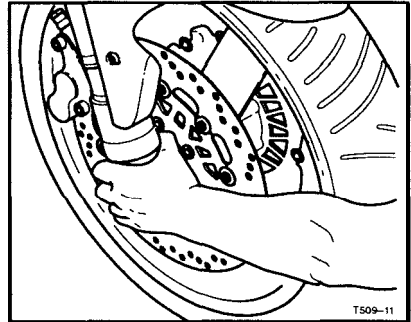

Inspecting the Steering for Free-Play Inspection

- Position the motorcycle on level ground, in an upright position.
- Remove the belly panel (where fitted).
- Raise the front wheel off the ground and place a block beneath the engine to support the motorcycle.
- Hold the lower end of the front forks and try to move them forward and backward.
- If any free-play can be detected, ask your authorised Triumph dealer to inspect and rectify any faults before riding.

! WARNING: Riding the motorcycle with incorrectly adjusted or defective steering may cause loss of motorcycle control and an accident.

- Leaving the support in place, inspect the wheel bearings as described over.

Maintenance and Adjustment

Wheel Bearings inspection

If the wheel bearings in the front or rear wheel allow play in the wheel hub, are noisy, or if the wheel does not turn smoothly, have your authorised Triumph dealer inspect the wheel bearings.

The wheel bearings must be inspected at the intervals specified in the scheduled maintenance chart.

- Gently rock the top of the front wheel from side to side.
- If any free-play can be detected, ask your authorised Triumph dealer to inspect and rectify any faults before riding.
- Reposition the lifting device and repeat for the rear wheel.

A **WARNING: Operation with worn or damaged wheel bearings may cause impaired handling and instability leading to an accident. If in doubt, have the motorcycle inspected by an authorised Triumph dealer before riding.**

- Remove the support and place the motorcycle on the side stand.
- Refit the belly panel (where fitted).

FRONT SUSPENSION

All models are fitted with forks which are adjustable for spring pre load, compression damping and rebound damping.

Front Fork Inspection

- Examine each fork stanchion for any sign of damage, scratching of the slider surface, or for oil leaks.
- If any damage or leakage is found consult an authorised Triumph dealer.

To check that the forks operate smoothly:

- Position the motorcycle on level ground.
- While holding the handlebars and applying the front brake, pump the forks up and down several times.

NOTE:

- The suspension movement will be affected by adjustment settings.
- If roughness or excessive stiffness is detected, consult your authorised Triumph dealer.



WARNING: Riding the motorcycle with defective or damaged suspension can damage the motorcycle, cause loss of control, or an accident.



WARNING: Never attempt to dismantle any part of suspension units as all units contain pressurised gas. Skin and eye damage can result from contact with the pressurised gas.

Maintenance and Adjustment

LOADING		FRONT			REAR	
		SPRING PRE-LOAD*	REBOUND DAMPING*	COMPRESSION DAMPING*	REBOUND DAMPING*	COMPRESSION DAMPING*
SOLO RIDING	STANDARD	5.00	1.00	1.00	1.00	1.00
	SOFTER	6.00	1.25	1.50	1.50	1.50
	FIRMER	4.00	0.75	0.50	0.50	0.50
RIDER AND PASSENGER		4.00–5.00	0.75–1.0	0.50–1.0	0.75	0.50
* Number of adjuster turns out from the fully screwed in position.						

NOTE:

This chart is only a guide. Setting requirements may vary for rider weight and personal preferences. See the following pages for details of how to adjust your suspension.

Front Suspension Settings

The standard suspension settings provide a comfortable ride and good handling characteristics for general, solo riding. The chart shows suggested settings for front and rear suspension.

A **WARNING:** Ensure that the correct balance between front and rear suspension is maintained. Suspension imbalance could significantly change handling characteristics leading to loss of control and an accident. Refer to the chart above for further information or consult your Triumph dealer.

 **WARNING:** Ensure that the adjusters are set to the same setting on both forks. Settings which vary from left to right hand forks may affect handling resulting in loss of control, and an accident.

NOTE:

- The setting figures above/over are all measured as adjuster turns out from the fully screwed in position.

The spring pre-load and rebound damping adjusters are located in the top of each fork. The compression damping adjuster is located near the bottom of each fork, adjacent to the wheel spindle.

Maintenance and Adjustment

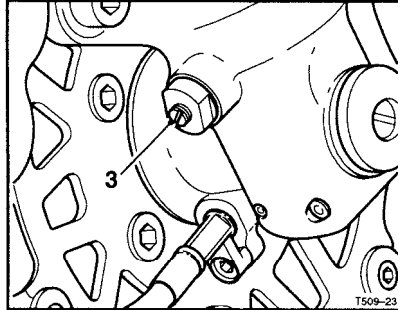
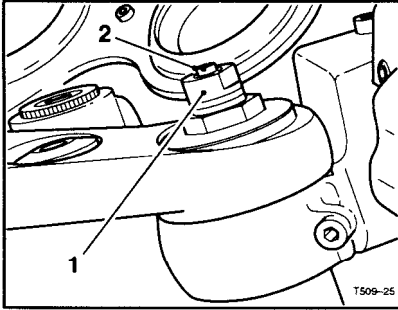

1. Spring Pre-load Adjuster
2. Rebound Damping Force Adjuster

3. Compression Damping Force Adjuster

Spring Pm-load Adjustment

To change the spring pre-load, rotate the adjuster clockwise (screw-in) to increase pre-load, or anti-clockwise (screw-out) to decrease pre-load. Always set the pre-load adjusters such that there are an equal number of graduation lines visible on both forks.

NOTE:

- The motorcycle is delivered from the factory with the spring pre-load set on position 5.

Compression Damping Adjustment

To change the compression damping force rotate the slotted adjuster clockwise (screw-in) to increase, or anti-clockwise (screw-out) to decrease.

Maximum damping force is obtained when the adjuster is rotated fully clockwise (screwed fully in).

Minimum damping force is obtained when the adjuster is rotated fully anti-clockwise (screwed fully out). Always count the turns out from the screwed fully in position and set both forks to the same setting.

NOTE:

- The motorcycle is delivered from the factory with the compression damping set at position 1.

Rebound Damping Adjustment

To change the rebound damping force, rotate the slotted adjuster clockwise (screw-in) to increase, or anti-clockwise (screw-out) to decrease. Always count the turns out from the screwed fully in position and set both forks to the same position.

Maximum damping force is obtained when the adjuster is rotated fully clockwise (screwed fully in).

Minimum damping force is obtained when the adjuster is rotated fully anti-clockwise (screwed fully out).

NOTE:

- The motorcycle is delivered from the factory with the rebound set at position 1.

Maintenance and Adjustment

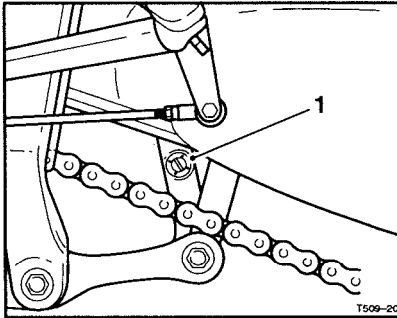

1. Rebound Damping Adjuster

REAR SUSPENSION ADJUSTMENT

The rear suspension unit is adjustable for both compression and rebound damping.

Rebound Damping Adjustment

The rebound damping adjuster is situated at the lower left hand end of the rear suspension unit.

To adjust the rebound damping setting, rotate the adjuster clockwise to increase rebound damping and anti-clockwise to decrease.

NOTE

- The settings are all measured as the number of adjuster turns out from the fully screwed in position.
- The motorcycle is delivered from the factory with the rebound adjuster set to position 1.

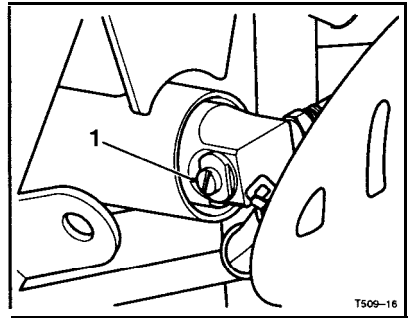

1. Compression Damping Adjuster

Compression Damping Adjustment

The compression damping adjuster is situated on the rear suspension unit reservoir.

To adjust the compression damping setting, rotate the slotted adjuster clockwise (screw-in) to increase, or anti-clockwise (screw-out) to decrease.

NOTE:

- The motorcycle is delivered from the factory with the compression damping set at 1.

A **WARNING:** Rear suspension unit spring pm-load is not rider adjustable. Any attempt to adjust the spring pre-load could result in a dangerous riding condition leading to loss of control and an accident.

Maintenance and Adjustment

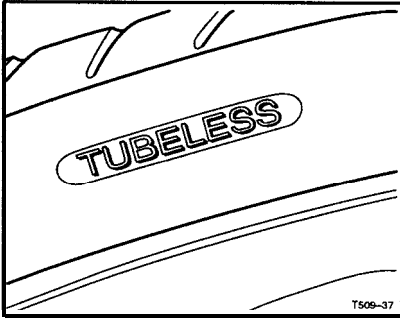

Typical Tyre Marking

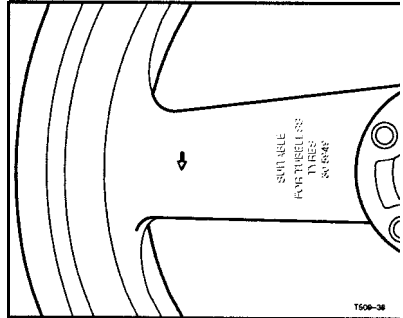

Wheel Marking

TYRES



This motorcycle is equipped with tubeless tyres, valves and wheel rims. Use only tyres marked 'TUBELESS' and tubeless valves on rims marked 'SUITABLE FOR TUBELESS TYRES'.

Tyre Inflation Pressures

Correct inflation pressure will provide maximum stability, rider comfort and tyre life. Always check tyre pressures before riding when the tyres are cold. Check tyre pressures daily and adjust if necessary. See the specification section for details of the correct inflation pressures.

A WARNING: Incorrect tyre inflation will cause abnormal tread wear and instability problems which may lead to loss of control and an accident.

Under-inflation may result in the tyre slipping on, or coming off the rim. Over-inflation will cause instability and accelerated tread wear.

Both conditions are dangerous as they may cause loss of control leading to an accident.

Maintenance and Adjustment

Tyre Wear



As the tyre tread wears down, the tyre becomes more susceptible to punctures and failure. It is estimated that 90% of all tyre failures occur during the last 10% of tread life (90% worn). It is, therefore, false economy and unsafe to use tyres until they are worn to their minimum.

- In accordance with the periodic maintenance chart, measure the depth of the tread with a depth gauge, and replace any tyre that has worn to the minimum allowable tread depth.

Minimum Recommended Tread Depth

Under 130 km/h (80 mph)	2 mm (0.08 in)
Over 130 km/h (80 mph)	Rear 3 mm (0.12 in) Front 2 mm (0.08 in)

A **WARNING:** This motorcycle must not be operated above the legal road speed limit except in authorised closed course conditions.

A **WARNING:** Operation with excessively worn tyres is hazardous and will adversely affect traction, stability and handling which may lead to loss of control and an accident.

When tubeless tyres become punctured, leakage is often very slow. Always inspect tyres very closely for punctures. Check the tyres for cuts, imbedded nails or other sharp objects. Operation with punctured or damaged tyres will adversely affect stability and handling which may lead to loss of control or an accident.

Check the rims for dents or deformation. Operation with damaged or defective wheels or tyres is dangerous and loss of control or an accident could result.

Always consult your authorised Triumph dealer for tyre replacement, or for a safety inspection of the tyres.

Maintenance and Adjustment

Tyre Replacement

All Triumph motorcycles are carefully and extensively tested in a range of riding conditions to ensure that the most effective tyre combinations are approved for use on each model. It is essential that approved tyres, fitted in approved combinations, are used when purchasing replacement tyres. The use of non approved tyres, or approved tyres in non approved combinations, may lead to motorcycle instability and an accident. See the specification section for details of approved tyre combinations. Always have tyres fitted and balanced by your authorised Triumph dealer who has the necessary training and skills to ensure safe, effective fitment.



WARNING: If a tyre sustains a puncture, the tyre must be replaced. Failure to replace a punctured tyre, or operation with a repaired tyre can lead to instability, loss of control or an accident.



WARNING: Do not install tube-type tyres on tubeless rims. The bead will not seat and the tyres could slip on the rims, causing rapid tyre deflation that may result in a loss of vehicle control and an accident. Never install an inner tube inside a tubeless tyre. This will cause friction inside the tyre and the resulting head build-up may cause the tube to burst resulting in rapid tyre deflation, loss of vehicle control and an accident.



WARNING: If tyre damage is suspected, such as after striking the kerb, ask your authorised Triumph dealer to inspect the tyre both internally and externally. Remember, tyre damage may not always be visible from the outside. Operation of the motorcycle with damaged tyres could lead to loss of control and an accident.



WARNING: When replacement tyres are required, consult your authorised Triumph dealer who will arrange for the tyres to be selected, in a correct combination, from the approved list and fitted according to the tyre manufacturer's instructions.

When tyres are replaced, allow time for the tyres to seat to the rim (approximately 24 hours). During this seating period, ride cautiously as an incorrectly seated tyre could cause loss of control or an accident.

Initially, the new tyres will not produce the same handling characteristics as the worn tyres and the rider must allow adequate riding distance (approximately 100 miles) to become accustomed to the new handling characteristics.

Maintenance and Adjustment

A WARNING (continued from previous page): 24 hours after fitting, the tyre pressures must be checked and adjusted, and the tyres examined for correct seating. Rectification must be carried out as necessary.

The same checks and adjustments must also be carried out when 100 miles have been travelled after fitting.

Use of a motorcycle with incorrectly seated tyres, incorrectly adjusted tyre pressures, or when not accustomed to its handling characteristics may lead to loss of control and an accident.

A WARNING: Tyres that have been used on a rolling road dynamometer may become damaged. In some cases, the damage may not be visible on the external surface of the tyre.

Tyres must be replaced after such use as continued use of a damaged tyre may lead to instability, loss of control and an accident.

A WARNING: Accurate wheel balance is necessary for safe, stable handling of the motorcycle. Do not remove or change any wheel balance weights. Incorrect wheel balance may cause instability leading to loss of control and an accident.

When wheel balancing is required, such as after tyre replacement, see your authorised Triumph dealer.

Only use self-adhesive weights. Clip on weights may damage the wheel and tyre resulting in tyre deflation, loss of control and an accident.

Maintenance and Adjustment

BATTERY



A **WARNING:** The battery gives off explosive gases; keep sparks, flames and cigarettes away. Provide adequate ventilation when charging or using the battery in an enclosed space.

The battery contains sulphuric acid (electrolyte). Contact with skin or eyes may cause severe burns. Wear protective clothing and a face shield.

- If electrolyte gets on your skin, flush with water immediately.
- If electrolyte gets in your eyes, flush with water for at least 15 minutes and **SEEK MEDICAL ATTENTION IMMEDIATELY.**
- If electrolyte is swallowed, drink large quantities of water and **SEEK MEDICAL ATTENTION IMMEDIATELY.**

KEEP ELECTROLYTE OUT OF THE REACH OF CHILDREN.

A **WARNING:** The battery contains harmful materials. Always keep children away from the battery whether or not it is fitted in the motorcycle.

Do not jump start the battery, touch the battery cables together or reverse the polarity of the cables as any of these actions may cause a spark which would ignite battery gases causing a risk of personal injury.

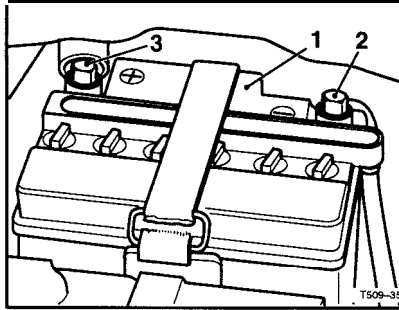

1. Battery
2. Negative Terminal
3. Positive Terminal

Battery Disposal

Should the battery ever require replacement, the original battery must be handed to a recycling agent who will ensure that the dangerous substances from which the battery is manufactured do not pollute the environment.

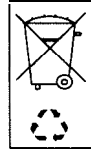

Battery Removal

- Remove the front seat
- Remove the battery strap and disconnect the breather tube.
- Disconnect the battery leads, negative (black) lead first.
- Take the battery out of the case.

! **WARNING:** Ensure that the battery terminals do not touch the motorcycle frame as this may cause a short circuit or spark which would ignite battery gases causing a risk of personal injury.

Maintenance and Adjustment

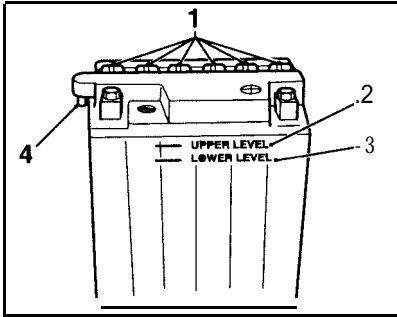

1. Filler Caps
2. Upper Level
3. Lower Level
4. Breather Tube Connection

- Clean the battery using a clean, dry, cloth. Be sure that the cable connections are clean.

Battery Electrolyte Level Inspection

A **WARNING:** The battery electrolyte is corrosive and poisonous and will cause damage to unprotected skin. Never swallow battery electrolyte or allow it to come into contact with the skin. To prevent injury, always wear eye and skin protection when adjusting the electrolyte level.

The battery electrolyte level must be kept between the upper and lower level lines. Check the electrolyte level in each cell in accordance with scheduled requirements.

- Remove the battery from the motorcycle.
- Check that the electrolyte level in each cell is between the upper and lower level lines.

- If the electrolyte level is low in any cell, fill with distilled water as follows:
- Remove the battery filler caps and fill with distilled water until the electrolyte level in each cell reaches the upper level line.
- Replace the caps.

CAUTION: When checking the battery electrolyte level, or adding distilled water, ensure that the breather tube is not blocked.

Use only distilled water in the battery. Tap water will shorten the service life of the battery.

Filling the battery above the UPPER LEVEL line may cause the electrolyte to overflow, resulting in corrosion to engine or nearby parts. Immediately wash off any spilled electrolyte.

CAUTION: The battery breather tube must be routed to prevent restrictions in the tube. Do not bend or twist the breather tube. A bent or kinked breather tube may pressurize the battery and damage its case.

Maintenance and Adjustment

Battery installation

A **WARNING:** Ensure that the battery terminals do not touch the motorcycle frame as this may cause a short circuit or spark which would ignite battery gases causing a risk of personal injury.

- Place the battery in the battery case, and connect the battery breather tube.
- Reconnect the battery, positive (red) lead first.
- Apply a light coat of grease to the terminals to prevent corrosion.
- Cover the positive terminal with the protective cap.
- Refit the battery strap.

WINDSCREEN CLEANING



Always clean the windscreen with clean water and a soft cloth. Dry after cleaning with a soft, lint free cloth. Minor scratches can be removed using a commercial polishing compound suitable for plastic.

The windscreen must be replaced if scratches cannot be completely removed.

A **WARNING:** Never attempt to clean the windscreen while the motorcycle is in motion as releasing the handlebars may cause loss of vehicle control and an accident.

Operation of the motorcycle with a damage or scratched windscreen will reduce the rider's forward vision. Any such reduction in forward vision is dangerous and may lead to an accident causing injury or death.



CAUTION: Corrosive chemicals such as battery electrolyte will damage the windscreen. Never allow corrosive chemicals to contact the windscreen.

Maintenance and Adjustment

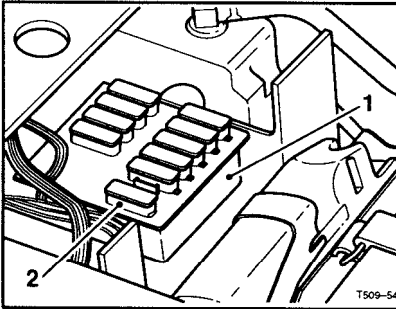

1. Fuse Box
2. Spare Fuses

FUSES

Fuses are arranged in the fuse box located under the front seat.

If a fuse fails during operation, inspect the electrical system to determine the cause, and then replace it with a new fuse of correct current rating.

A **WARNING:** Always replace blown fuses with new ones of the correct current rating (as specified on the fuse box cover) and never use a fuse of higher rating. Although no spare 5 Amp. fuse is supplied in the fuse box, it is strongly recommended that a spare 5 Amp. fuse be carried.

Fuse Identification

A blown fuse is indicated when all of the systems protected by that fuse become inoperative. When checking for a blown fuse, use the table below to establish which fuse has blown.

Fuse No	Circuits Protected	Fuse Rating
1	Ignition Control	10A
2	Dip and Main Beam Right Hand	15A
3	Side and Rear Light	5A
4	Indicators/Stop Light	10A
5	Fan	10A
6	Dip and Main Beam Left Hand	15A
7	Main Fuse	40A
8	Fuel Pump ECU	15A
9	All circuits from ignition switch	30A
10	Spare	-

NOTE:

- The fuse identification numbers listed above correspond with those printed on the fuse box cover.

Maintenance and Adjustment

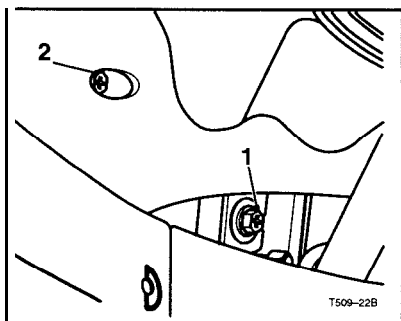

1. Vertical Adjustment Screw (LH)
2. Horizontal Adjustment Screw (LH)

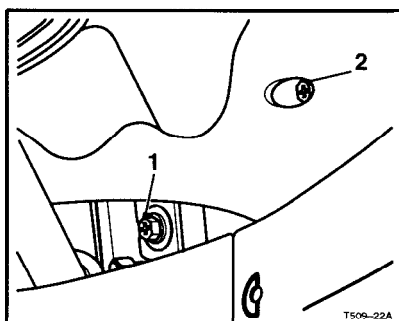

1. Vertical Adjustment Screw (RH)
2. Horizontal Adjustment Screw (RH)

HEADLIGHTS - DAYTONA

A **WARNING:** Adjust road speed to suit the visibility and weather conditions in which the motorcycle is being operated.

Ensure that the beam is adjusted to illuminate the road surface sufficiently far ahead without dazzling oncoming traffic. An incorrectly adjusted headlight may impair visibility causing an accident.

A **WARNING:** Never attempt to adjust the headlamp beam when the motorcycle is in motion.

Any attempt to adjust the headlamp beam when the motorcycle is in motion may result in loss of control and an accident.

Headlight Adjustment

- Each headlight can be adjusted by means of vertical and horizontal adjustment screws located on the rear of the headlight unit.
- Switch the headlight dipped beam on.
- Turn the vertical adjustment screw on each headlight clockwise to lower the beam or anti-clockwise to raise the beam.
- On the RH headlight turn the horizontal adjustment screw clockwise to move the beam to the right or anti-clockwise to move the beam to the left.
- On the LH headlight turn the horizontal adjustment screw anti-clockwise to move the beam to the right or clockwise to move the beam to the left.
- Switch the headlights off when the beam settings are satisfactory.

Maintenance and Adjustment

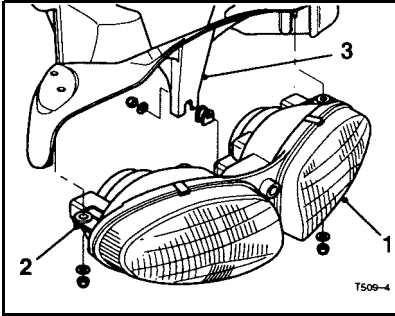

1. Headlight Unit
2. Side Fixing (RH)
3. Centre Fixing

Headlight Bulb Replacement

The complete headlight unit must be removed to gain access for bulb replacement.

- Remove the seat(s).
- Disconnect the battery, negative (black) lead first.
- Remove the cockpit.
- Unscrew the nuts securing the headlight unit to the support bracket and release the unit.
- Disconnect the multi-pin electrical connector from the bulb to be replaced and remove the rubber cover.
- Detach the wire bulb retainer from the clip. It is not necessary to undo the screw.
- Remove the bulb from the headlight unit.
- Installation is the reverse of the removal procedure.

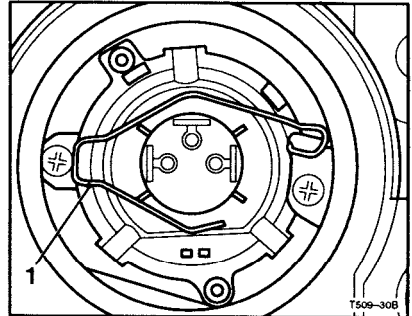

1. Bulb Retainer



CAUTION: When reconnecting the battery, connect the positive (red) lead first.



WARNING: Do not reconnect the battery until the assembly process has been completed. Premature battery reconnection could result in ignition of the battery gases causing risk of injury.



WARNING: The bulb becomes hot during use. Always allow sufficient time for the bulb to cool before handling.

Avoid touching the glass part of the bulb. If the glass is touched or gets dirty, clean with alcohol before re-use.

Position Lamp Bulb Replacement

The position lamp is fitted to the cockpit above the headlight aperture. Remove the cockpit panel to gain access for bulb replacement.

Maintenance and Adjustment

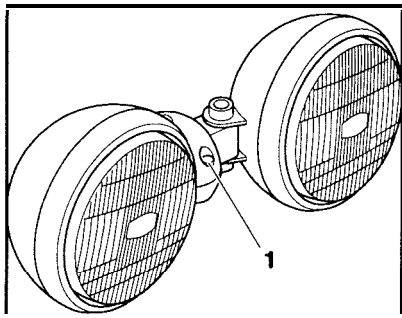

1. Vertical Adjustment Clamp

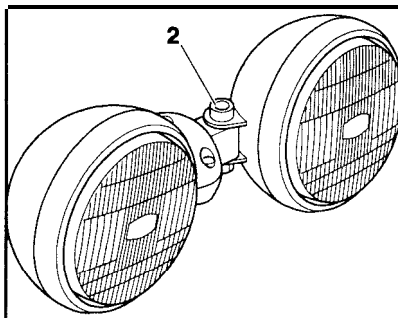

2. Horizontal Adjustment Clamp

HEADLIGHTS – SPEED TRIPLE

A **WARNING:** Adjust road speed to suit the visibility and weather conditions in which the motorcycle is being operated.

Ensure that the beam is adjusted to illuminate the road surface sufficiently far ahead without dazzling oncoming traffic. An incorrectly adjusted headlight may impair visibility causing an accident.

The horizontal beam of each headlight can be adjusted individually. The vertical beams are adjusted as a pair.

Headlight Adjustment

- Switch the headlight dipped beam on.
- Partially release the central clamp fixing on the headlight mounting bracket and pivot both headlights upward or downward as necessary.
- Tighten the central clamp fixing while holding the headlights in the desired position.
- Release the clamp fixing to the rear of the headlight bowl and pivot the headlamp to the left or right as necessary.
- Tighten the clamp fixing while holding the headlight in the desired position.
- Repeat for the other headlight.
- Switch the headlights off when the beam settings are satisfactory.

Maintenance and Adjustment

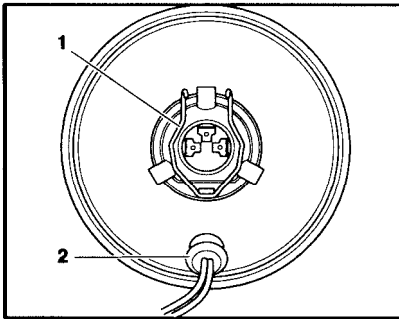

1. Bulb Retainer
2. Position Lamp

Headlight Bulb Replacement

Each halogen headlight bulb can be replaced as follows:

- Disconnect the battery, negative (black) lead first.
- Release the headlight bezel clamp screw.
- Support the headlight unit and remove the bezel. Ease the headlight from the headlight bowl.
- Disconnect the multi-pin electrical connector from the headlight bulb and remove the rubber cover.
- Unhook the wire retaining clip from behind the bulb.
- Remove the bulb from the headlight unit.
- Installation is the reverse of the removal procedure.

CAUTION: When reconnecting the battery, connect the positive (red) lead first.

A WARNING: Do not reconnect the battery until the assembly process has been completed. Premature battery reconnection could result in ignition of the battery gases causing risk of injury.

A WARNING: The bulb becomes hot during use. Always allow sufficient time for the bulb to cool before handling.

Avoid touching the glass part of the bulb. If the glass is touched or gets dirty, clean with alcohol before re-use.

Position Lamp Bulb Replacement

Position lamps are fitted to both headlight units. To replace a position light bulb, remove the headlight unit from the headlight bowl to gain access for position light bulb replacement.

Maintenance and Adjustment

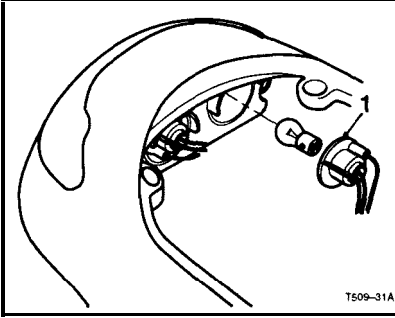

1. Rear Light Bulb Retainer

REAR LIGHT

Bulb Replacement-All Models

- Remove the rear seat/cover to gain access to the tail light unit.
- Rotate the bulb holder anti-clockwise to release.
- Replace the bulb. Fit the bulb holder to the tail light unit.
- Refit the seat/cover

LICENCE PLATE LIGHT

Bulb Replacement-All Models

- Remove the side panels to gain access to the licence plate light unit.
- Carefully remove the rubber bulb holder from the back of the light unit.



CAUTION: To avoid cable damage, do not pull the bulb holder using the cables.

- Replace the bulb. Fit the bulb holder to the light unit.
- Refit the seat/cover.

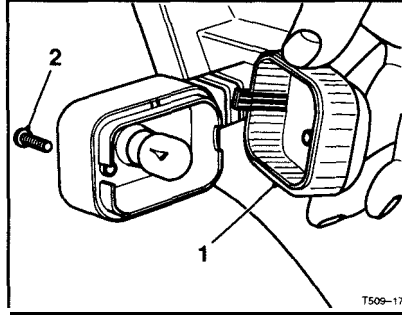

1. Indicator Lens
2. Securing Screw

INDICATOR LIGHT

Bulb Replacement-All Models

The lens on each indicator light is held in place by a securing screw located in the body of the light.

- Release the screw and remove the amber lens to gain access to the bulb for replacement.

Maintenance and Adjustment

CLEANING

Frequent, regular cleaning is an essential part of the maintenance of your motorcycle. If regularly cleaned, the appearance will be preserved for many years. Cleaning with warm water containing an automotive cleaner is essential at all times but particularly so after exposure to sea breezes, sea water, dusty or muddy roads and in winter when roads are treated for ice and snow.

Although, under the terms of your motorcycle warranty, cover is provided against the corrosion of certain items, the owner is expected to observe this reasonable advice which will safeguard against corrosion and enhance the appearance of the motorcycle. Do not use household detergent as the use of such products will lead to premature corrosion.

Preparation for Washing

Before washing, precautions must be taken to keep water off the following places.

- Rear opening of the muffler: Cover with a plastic bag secured with rubber bands.
- Clutch and brake levers, switch housings on the handlebar: Cover with plastic bags.
- Ignition switch: Cover the keyhole with tape.
- Air cleaner intakes: Close up the intakes with tape.

Where to be Careful

Avoid spraying water with any great force near the following places:

- Instruments.
- Brake cylinders and brake calipers.
- Under the fuel tank.
- Drive chain and headstock bearings.

NOTE:

- Coin operated, high pressure spray **washers are not recommended. The water may be forced into bearings and other components causing eventual failure from rust and corrosion. Some of the soaps which are highly alkaline leave a residue or cause spotting.**

After Washing

- Remove the plastic bags and tape, and clear the air intakes.
- Lubricate the pivots, bolts and nuts.
- Test the brakes before motorcycle operation.
- Start the engine and run it for 5 minutes. **Ensure adequate ventilation for the exhaust fumes.**
- Use a dry cloth to absorb water residue. Do not allow water to stand on the machine as this will lead to corrosion.

Maintenance and Adjustment

A WARNING: Never wax or lubricate the brake discs. Loss of braking power and an accident could result. Clean the disc with a proprietary brand of oil free brake disc cleaner.

Unpainted Aluminium Items

- Items such as brake and clutch levers must be correctly cleaned to preserve their appearance.
- Use a proprietary brand of aluminium cleaner which does not contain abrasive or caustic elements.
- Clean aluminium items regularly, in particular after use in inclement weather, where the components must be hand washed and dried each time the machine is used.
- Warranty claims due to inadequate maintenance will not be allowed.

Cleaning of the Exhaust System:

All parts of the exhaust system of your motorcycle must be cleaned regularly to avoid a deterioration of its appearance. These instructions can be applied to black chrome, brushed stainless steel and carbon fibre components alike.

NOTE:

- **The exhaust system must be cool before washing to prevent water spotting.**

Washing

- Prepare a mixture of water and mild soap. Do not use a high alkaline content soap as commonly found at commercial car washes because it leaves a residue.

- Wash the exhaust system with a soft cloth. Do not use an abrasive scouring pad or steel wool. They will damage the finish.
- Rinse the exhaust system thoroughly.
- Ensure no soap or water enters the mufflers.

Drying

- Dry the exhaust system completely with a soft cloth. Do not run the engine to dry the system or spotting will occur.

Protecting

- When the exhaust system is dry, rub 'Motorex 645 Clean And Protect' into the surface.



CAUTION: The use of silicone products such as WD40 will cause discolouration of the chrome and must not be used. Similarly, the use of abrasive cleaners such as Solvol Autosol will damage the system and must not be used.

- It is recommended that regular protection be applied to the system as this will both protect and enhance the system's appearance.

Storage

Preparation for Storage:

- Clean the entire vehicle thoroughly.
- Empty the fuel from the fuel tank into a secure container.

A **WARNING:** Petrol is extremely flammable and can be explosive under certain conditions. Turn the ignition switch OFF. Do not smoke. Make sure the area is well ventilated and free from any source of flame or sparks; this includes any appliance with a pilot light.

- Remove the spark plugs and put several drops (5 ml) of engine oil into each cylinder. Push the starter button for a few seconds to coat the cylinder walls with oil, and install the spark plugs.
- Reduce tyre pressure by about 20%.
- Set the motorcycle on a box or stand so that both wheels are raised off the ground. (If this cannot be done, put boards under the front and rear wheels to keep dampness away from the tyre rubber).
- Spray oil on all unpainted metal surfaces to prevent rusting. Prevent oil from getting on rubber parts, brake discs or in the brake calipers.
- Lubricate the drive chain and all the control cables.
- Remove the battery, and store it where it will not be exposed to direct sunlight, moisture, or freezing temperatures. During storage it should be given a slow charge (one ampere or less) about once a month. Keep the battery well charged during

cold weather so that the electrolyte does not freeze and crack the battery. The more discharged the battery becomes, the more easily it freezes.

- Tie plastic bags over the exhaust pipe to prevent moisture from entering.
- Put a cover over the motorcycle to keep dust and dirt from collecting on it.

Preparation after Storage:

- Check the electrolyte level in the battery, charge the battery if necessary, and install it in the motorcycle. Be careful that the battery vent hose is not pinched and that it is routed as shown on the label.
- Fill the fuel tank with fuel.
- Change the engine oil and filter.
- Check all the points listed in the Daily Safety Checks section.
- Before starting the engine, remove spark plugs.
- Put side stand down. This will isolate the ignition and prevent stray sparks and damage to the ignition system.
- Crank the engine on the starter motor several times until the oil pressure light goes out.
- Replace spark plugs and start engine.
- Check brakes and operation.

Specifications

DAYTONA

SPEED TRIPLE

PERFORMANCE

Maximum Power	130 PS @ 10200rpm (r/min)	108 PS @ 9100rpm (r/min)
Maximum Torque	100.0 Nm @ 8500rpm (r/min)	85.0 Nm @ 7500rpm (r/min)

DIMENSIONS

Overall Length	2115mm	2115mm
Overall Width (to mirrors)	800mm	860mm
Overall Height	1170mm	1230mm
Wheelbase	1440mm	1440mm
Seat Height	800mm	800mm
Dry Weight	198kg	196kg
Maximum Payload	185kg	185kg
(rider & passenger & accessories)		

ENGINE

Type	in-line 3 cyl.	in-line 3 cyl.
Displacement	955cc	885cc
Bore x Stroke	79x65mm	76x65mm
Compression Ratio	11.2:1	11.0:1
Cylinder Numbering	Left to Right	Left to Right
Sequence	1-2-3	1-2-3
Firing Order	1-2-3	1-2-3
Starting System	Electric Starter	Electric Starter

LUBRICATION

Lubrication System	Forced Lubrication (wetsump)	Forced Lubrication (wetsump)
Engine Oil	Semi or fully synthetic 10W/40 motorcycle engine oil which meets API SH specification	Semi or fully synthetic 10W/40 motorcycle engine oil which meets API SH specification
Engine Oil Capacity	4.00 litres	4.00 litres
(including filter, wet fill)		

Specifications

	DAYTONA	SPEED TRIPLE
COOLING		
Coolant Type	Mobil Antifreeze	Mobil Antifreeze
Mixture Ratio	50/50	50/50
Coolant Capacity	2.0 litre	2.0 litre
Thermostat Opens (nominal)	85 °C	85 °C
FUEL SYSTEM		
Type	Electronic Fuel Injection	Electronic Fuel Injection
Injectors	Twin Pencil Solenoid Operated Plate Valve	Twin Pencil Solenoid Operated Plate Valve
Fuel Pump	Submerged Electric	Submerged Electric
Fuel Pressure	3 Bar	3 Bar
FUEL		
Type	Unleaded (95 RON)	Unleaded (95 RON)
Tank Capacity	18 Litres	18 Litres
IGNITION		
Ignition System	Digital Inductive	Digital Inductive
Electronic Rev Limiter	10,800rpm (r/min)	9,700rpm (r/min)
Spark Plug	NGK DPR 8EA-9	NGK DPR 8EA-9
Gap	0.8-0.9mm	0.8-0.9mm

Specifications

	DAYTONA	SPEED TRIPLE
TRANSMISSION		
Transmission Type.	6 Speed, Constant Mesh	6 Speed, Constant Mesh
Clutch Type.....	Wet, Multi-Plate	Wet, Multi-Plate
Primary Drive.....	Gear	Gear
Final Drive.....	Chain	Chain
	Regina 136 ORP 108 Link Endless	Regina 136 ORP 108 Link Endless
Primary Drive Ratio.....	1.75 (105/60)	1.75 (105/60)
Final Drive Ratio.....	2.388 (43/18)	2.388 (43/18)
Gear Ratio: 1st.....	2.733 (41/15)	2.733 (41/15)
2 n d.....	1.947 (37/19)	1.947 (37/19)
3 r d.....	1.545 (34/22)	1.545 (34/22)
4 t h.....	1.291 (31/24)	1.291 (31/24)
5 t h.....	1.154 (30/26)	1.154 (30/26)
6 t h.....	1.074 (29/27)	1.074 (29/27)
TYRES		
Tyre Pressures (Cold)		
F r o n t.....	2.5kg/cm2 (36lb/in ²)	2.5kg/cm2 (36lb/in ²)
R e a r.....	2.9kg/cm2 (42lb/in ²)	2.9kg/cm2 (42lb/in ²)
Option 1	F r o n t.....	Bridgestone BT56 120/70/17
	R e a r.....	Bridgestone BT56 190/50/17
Option 2	Front Michelin Hi-Sport TX1 5	Michelin Hi-Sport TX15
	Rear Michelin Hi-Sport TX25	Michelin Hi-Sport TX25

A **WARNING: Use recommended tyre options ONLY in the combinations given. Do not mix tyres from different manufacturers or mix different specification tyres from the same manufacturers.**

Specifications

BOTH MODELS

ELECTRICAL EQUIPMENT

Battery	12V 14AH
Alternator	12V 40A
Headlight	Halogen H4
Tail/Brake Light	2x12V 5/21W
Directional Indicator Lights .	12v 10W

FRAME

Castor	24*
Trail	86mm
Tightening Torques	
Oil Filter	8-12Nm
Sump Drain Plug	24Nm
Spark Plug	18Nm
Rear Wheel Eccentric Clamp Bolt	50Nm

FLUIDS AND LUBRICANTS

Engine Oil:

Fully synthetic motorcycle engine oil which meets specification API SH, such as Mobil 1 Racing 4T 10W40
 Brake and Clutch Fluid Mobil Universal Brake Clutch Fluid DOT4
 Coolant Mobil Antifreeze
 Bearings and Pivots Mobil Grease HP 2 2 2
 Drive Chain Mobil Chain Spray
 or MobilubeHD80

NOTE:

Mixing different specification oils or mixing oils of the same specification but of a different brand is not recommended except in emergency. If in emergency, oils of different brands or specifications do become mixed, change the engine oil and filter at the earliest opportunity. Engine oils are of a fully synthetic type and must never be mixed with any other types of oil.

Alphabetical Index

Battery	62	Cooling System	44
Battery Disposal	62	Coolant Change	44
Battery Electrolyte Level Inspection	63	Coolant Level Inspection.....	45
Battery Installation	64	Corrosion Inhibitors	44
Battery Removal	62	Radiator and Cooling Fan	44
Brakes		Radiator Hoses	44
Brake Fluid Level Inspection and		Dimensions	74
Adjustment	52	Drive Chain	48
Brake lever adjuster	19	Chain Free-movement Adjustment	48
Brake Light Switches	53	Chain Free-movement Inspection	48
Brake Pad Wear Compensation	52	Chain Lubrication	50
Brake Wear Inspection	51	Chain Wear Inspection	49
Disc Brake Fluid	51	Electrical Equipment	77
Braking	30	Engine.....	74
Changing Gears	29	Engine serial number	13
Cleaning	71	Engine Oil	41
After Washing	71	Disposal of Used Engine Oil	43
Cleaning of the Exhaust System	72	Oil and Oil Filter Change	42
Drying	72	Oil Level Inspection	41
Preparation for Washing	71	Fluids And Lubricants	77
Protecting	72	Frame	77
Unpainted Aluminium Items	72	Tightening Torques	77
Washing.....	72	Front Suspension	54
Where to be Careful	71	Compression Damping Adjustment	56
Clutch	47	Front Fork Inspection	54
Adjustment	47	Front Suspension Settings	55
Inspection	47	Rebound Damping Adjustment	56
Considerations For High Speed		Spring Pre-load Adjustment	56
Operation	33	Fuel	75
Brakes	33	Fuel Requirement	22
Coolant	33	Fuel System	75
Electrical Equipment	33	Fuel Tank Cap	22
Engine Oil	33	Refuelling	22
Fuel	33		
Miscellaneous.....	33		
Steering.....	33		
Tyres	33		
Coolant Temperature Gauge	17		
Cooling	75		

Alphabetical Index

Fuses.....	65	Right Handlebar Switches	20
Fuse Identification	65	Engine Stop Switch	20
Handbook Storage	23	Starter Button	20
Headlights - Daytona	66	Running-in	24
Headlights - Speed Triple	68	Safe Operation	25
Ignition	75	Daily Safety Checks	25
Ignition Key	18	Scheduled Maintenance	38
Ignition Switch/Steering Lock	18	Seat Lock Operation/Seat Removal	23
Indicator Light	70	Side Panel	40
Bulb Replacement - All Models ...	70	Side Panel Refitting	40
Instrument Panel Layout	16	Side Panel Removal	40
Left Handlebar Switches		Speedometer	16
Direction Indicator Switch	21	Stand	23
Headlight Dip Switch	21	Steering/Wheel Bearings	53
Headlight Switch	21	Inspection	53
Horn Button	21	Steering Inspection	53
Passing Button	21	Wheel Bearings Inspection	54
Left Handlebar Switches	21	Storage	
Licence Plate, Bulb Replacement - All Models..	70	Preparation after Storage	73
Licence Plate Light	70	Preparation for Storage	73
Lubrication	74	Table of Contents	2
Noise Control System	3	Tachometer	16
Parking	32	Throttle Grip	46
Performance..	74	Adjustment	46
Rear Light	70	Inspection	46
Bulb Replacement - All Models ...	70	To Start The Engine	28
Rear Suspension Adjustment	57	To Stop The Engine	28
Compression Damping Adjustment	57	Tool Kit	23
Rebound Damping Adjustment ..	57	Transmission	76

Alphabetical Index

Tyres	58,76
Minimum Recommended Tread	
Depth	59
Tyre Inflation Pressures	58
Tyre Pressures (Cold)	76
Tyre Replacement	60
Tyre Wear	59
Vehicle, Vehicle identification number (V.I.N.)	13
Warning Lights	17
Warnings	
Warning label location	8
Warning Labels	1
Warning, Caution and Note	3
Windscreen Cleaning	64