

Model Code/s:
EUF172W

Product:
Vertical Freezer

Document:
User Manual

Esatto



Dear Customer,

Congratulations on purchasing your vertical freezer. The *Esatto* brand is proudly distributed within Australia by Residentia Group Pty Ltd.

Please refer to the warranty card at the rear of this manual for information regarding your product's parts and labour warranty, or visit us online at www.residentiagroup.com.au.

At Residentia Group, we are customer obsessed and our Support Team are there to ensure you get the most out of your appliance. Should you want to learn more about your vertical freezer or importantly taking care of the freezer, our Support Team are here to help.

You can use our online Support Centre at anytime by visiting <http://support.residentiagroup.com.au>, or you can contact us via phone by dialling: 1300 11 HELP (4357).

It is important that you read through the following use and care manual thoroughly to familiarise yourself with the installation and operation requirements of your appliance to ensure optimum performance.

Again, thank you for choosing an *Esatto* appliance and we look forward to being of service to you.

Kind Regards,
The Residentia Team



Contents:

Page:

Safety instructions	4
Your Esatto Vertical Freezer	4
Installation Instructions	5
Operating your Vertical Freezer	7
Cleaning and maintenance	8
Troubleshooting	9
Technical Specifications	9
Warranty information	10



Safety Instructions

- This appliance is only intended for use within a domestic environment only.
- This appliance is not intended for use by persons (including children) with reduced physical, sensory or mental capabilities, or lack of experience and knowledge, unless they have been given supervision or instruction concerning use of the appliance by a person responsible for their safety.
- Children should be supervised to ensure that they do not play with the appliance.

UNPACKING

- During transportation, protective packaging was used to protect the appliance against any damage. After unpacking, please dispose of all elements of packaging in a way that will not cause damage to the environment. All materials used for packaging the appliance are environmentally friendly; they are 100% recyclable and are marked with the appropriate symbol.

Caution! During unpacking, the packaging materials (polythene bags, polystyrene pieces, etc.) should be kept out of reach of children.

DISPOSAL OF THE APPLIANCE

- Old appliances should not simply be disposed of with normal household waste, but should be delivered to a collection and recycling centre for electric and electronic equipment. A symbol shown on the product, the instruction manual or the packaging shows that it is suitable for recycling.
- Materials used inside the appliance are recyclable and are labelled with information concerning this. By recycling materials or other parts from used devices you are making a significant contribution to the protection of our environment.
- Information on appropriate disposal centres for used devices can be provided by your local authority.

Your Esatto Vertical Freezer

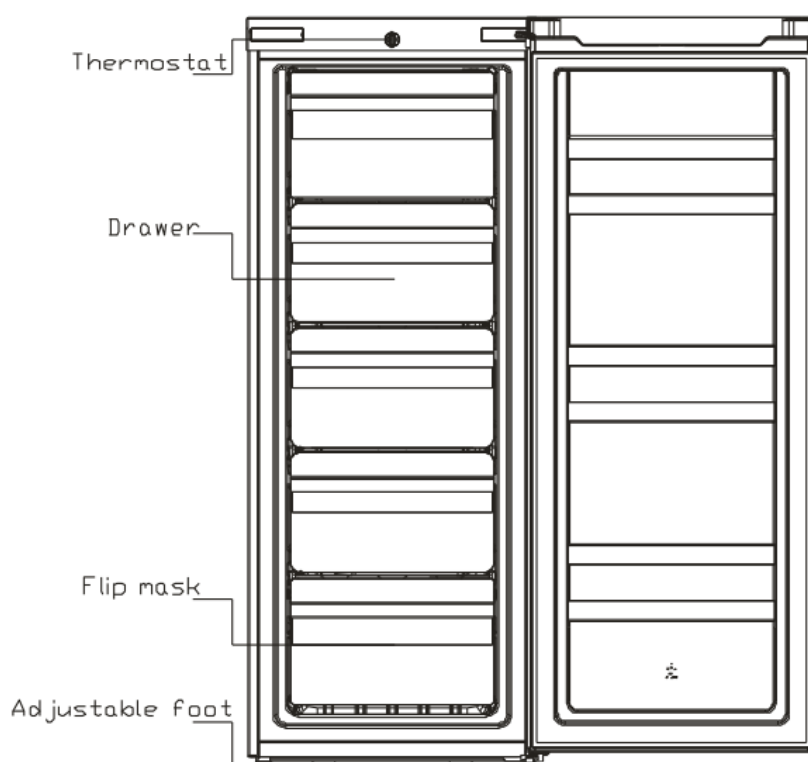

Installation Instructions

POWER SOURCE AND GROUNDING

It's recommended to use the vertical freezer on its own dedicated power outlet for both convenience and safety. The power outlet must be grounded.

Important! If the power cord is damaged, it must be replaced by Residientia Group or one of its authorised service representatives. Please contact 1300 11 HELP (4357) and ensure the appliance is completely disconnected from the power supply.

LOCATION

When selecting a position for the vertical freezer, ensure that the floor is firm, flat and level, along with the room being well ventilated. Avoid locating the appliance near a heat source (ie. heater, oven or boiler). Also avoid direct sunlight as it may increase the electrical consumption and/or effect the freezer's performance. This appliance is not designed for use within a garage or an outdoor installation. Do not drape the appliance with any covering.

When installing the appliance, ensure that 15cm of free space is left on either side, 15cm of space at the rear and at least 30cm of free space above. This will allow cold air to circulate around the freezer and improve the efficiency of the freezing process.

REVERSING THE DOOR SWING

Tools Required: Phillips Head screwdriver/ Flat Head screwdriver/ Hexagonal spanner.

1. Remove the top right hinge cover.
2. Remove the screws that fix the top hinge into place, using the Phillips Head screwdriver.
3. On the removed top door hinge, remove the door hinge pin that holds the door in place and swap to the other side of the hinge bracket (as shown below).

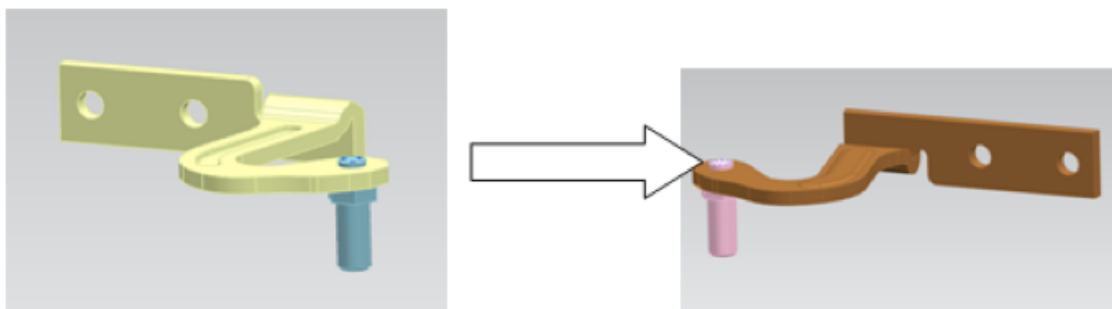

4. This hinge will be fixed into place on the other (top) side of the freezer, as the last step (NOT YET).
5. Remove the door limit block from the top of the door and move to the other side of the door (as shown below).

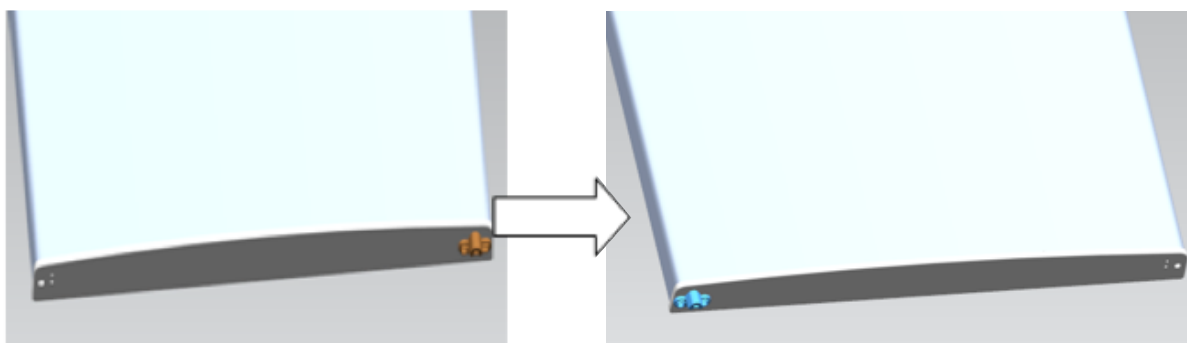

6. Now remove the screws fixing the bottom hinge with the Phillips Head screwdriver.

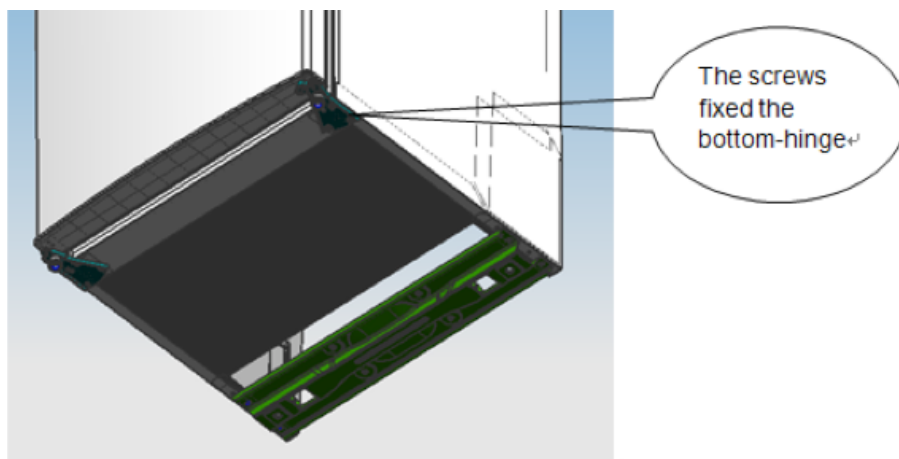

Note: Whilst removing the bottom hinge, ensure the freezer incline angle is less than 45 degrees. Never lay it flat.

7. Follow the same procedure as was used with inverting the hinge pivot point in the upper hinge bracket and fix the bottom hinge bracket in place on the other side of the freezer.
8. Insert the door into the bottom hinge pivot and re-fix the top hinge bracket, securing the door into place.
9. Replace the hinge covers and use the levelers to ensure the freezer is level.

DOOR SPACE REQUIREMENTS

When the freezer's door is completely open, the freezer requires a clearance of 902mm (W) x 1052mm (D).

LEVELING THE UNIT

To level the unit, adjust the two leveling feet at the front of the unit. If the unit is not level, the door and magnetic seal alignments will not be covered properly, leading to inefficient freezing performance. Ensure that the feet all touch the ground before use.

CLEANING BEFORE USE

Wipe the inside of the unit with a weak solution of bicarbonate soda. Then rinse with warm water using a 'Wrung-out' sponge or cloth. Wash the shelves and salad bin in warm soapy water and dry completely before replacing in the unit. Clean the exterior of the unit with a damp cloth.

If you require more information refer to the Cleaning section.

INTERIOR ACCESSORIES:

Various glass or plastic storage shelves are included with your appliance - different models have different combinations.

You should always slide one of the full size glass storage shelves into the lowest set of guides, above the fruit and vegetable containers, and keep it in this position. To do this, pull the storage shelf forward until it can be swiveled upwards or downwards and removed.

Please do the same in reverse to insert the shelf at a different height.

Important! In order to make the most of the volume of the fresh food storage compartment and frozen-food storage compartment, the user can remove one or more shelves, drawers, out of the appliance, according to your daily use.

BEFORE FIRST USE:

- Do not use when the power cord is damaged or the plug is worn.
- Do not alter the power cord under any circumstances, so as to ensure safe use.
- Do not put flammable, explosive, volatile and highly corrosive items in the refrigerator to prevent damages to the product or fire accidents.
- Do not place flammable items near the refrigerator to avoid fires.
- This product is a household refrigerator and is only suitable for the storage of foods. According to national standards, household refrigerators shall not be used for other purposes, such as storage of blood, drugs or biological products.
- Do not place items such as bottled or sealed container of fluid such as bottled beers and beverages in the freezer to prevent bursts and other losses.
- Before placing any food in your unit, turn it on and wait for 24 hours, to make sure it is working properly and to allow it time to fall to the correct temperature. Your unit should not be overfilled.

Important! Before plugging in your freezer, you must check that you have a power outlet which is compatible with the plug supplied on the appliance lead. You must also wait at least two hours after moving the unit, before turning the appliance on.

Operating Your Vertical Freezer

1. **SWITCHING ON YOUR FREEZER**
 - The temperature selector knob is located on the right hand side wall of the refrigerator interior.
Setting “Min” = Moderate cool temperature
Setting “Mid” = Normal operation (suitable for most environments)
Setting “Max”= Coolest temperature
 - During high ambient temperature days (ie. hot summer days), it may be necessary to set the thermostat to the coolest setting (“Max”). This may cause the compressor to run continuously in order to maintain a low temperature within the cabinet.
 - For the first time you install your refrigerator, set the thermostat knob at “Mid” and give your refrigerator time to cool down completely before adding food (normally upto 24 hours).
 - Please ensure that the power cord is in perfect condition before use. Should there be any damage to the power cord or plug, please immediately isolate the dryer from power and contact Residentia Group on 1300 11 HELP (4357).

2. **NOISE FROM YOUR FREEZER**
 - You may notice that your freezer makes some unusual noises. This is completely normal for refrigerators and freezers, and the noises are caused by the circulation of the refrigerant liquid within the cooling system.

3. **TIPS FOR KEEPING FOOD WITHIN THE FREEZER**
 - Cooked meats & fish should always be stored on a shelf above raw meat/ fish to avoid bacterial transfer. Keep raw meat/fish in a container which is large enough to collect juices and cover properly. Place the container on to the lowest shelf.
 - Leave space around your food to allow air to circulate inside the unit. Ensure all parts of the appliance are kept cool.
 - To prevent transfer of flavours and drying out, pack or cover the food separately. Fruit and vegetables do not need to be wrapped.
 - Always let pre-cooked food cool down before you place into the freezer. This will help to maintain the internal temperature of the freezer.
 - To prevent cold air from escaping the freezer, try to limit the number of times you open the door.

Cleaning and Maintenance

By ensuring proper cleaning and maintenance of your Esatto Vertical Freezer, you can ensure that it will have a long and fault free operation.

Warning! To avoid an electric shock, always unplug your freezer before cleaning.

DEFROSTING

For the most efficient operation and minimum energy consumption, defrost the freezer when the frost on the freezer walls is excessive or 5mm thick. To minimize disruption, choose a time when the stock of frozen food is low.

Important! Do not use boiling water because it may damage the plastic parts. In addition, never use a sharp or metallic instrument to remove frost as it may damage the cooling coils and will void the warranty. We recommend using the plastic scraper.

- Remove the frozen food from the freezer and place it in a cooler to protect the food.
- Unplug the freezer. The Power Supply light should be off (green light out).
- During defrosting, the ice melts in the cabinet and drains out through the bottom front.
- Place a shallow pan outside the front base to capture the defrost water. Check the pan occasionally so the water does not overflow.
- Clean the interior of the freezer and wipe any residual ice or water from the cabinet.
- Reset the thermostat to desired setting.
- Switch on the temperature control to the highest setting for two hours before using, and then adjust to normal level.
- Return food to the freezer.

Helpful Tip. Defrosting usually takes a few hours. Leaving the door open will help speed the process. Also, pouring warm water (not boiling) on the ice/frost will help speed melting. If you must use a scraper- please use caution - it is very easy to damage the freezer compartment and void your warranty.

CLEANING THE INNER CABINET

Caution. Before using any cleaning products, please read and follow the manufacturer's instructions and warnings to avoid any damage to your Freezer or personal injury.

- Upon installation of your new appliance, it is recommended that it be cleaned thoroughly.
- Wash the inside with a damp warm cloth containing a water and baking soda solution. The solution should be about 2 tablespoons of baking soda to 2L of water.
- Wash the storage basket with a mild detergent solution.
- Be sure to keep the door seal clean to keep the unit running efficiently.
- The outside of the freezer should be cleaned with mild detergent and warm water.
- Dry the interior and exterior with a soft cloth.
- The condenser coils should be carefully vacuumed when they are dusty or dirty.
- It is recommended that the unit be cleaned each time it is defrosted to help keep the unit odour free and running efficiently.
- Clean your door gasket seals every 3 months using the same warm water solution described above.

Troubleshooting

OPERATION IN CASE OF EMERGENCY

In the event of an emergency you should:

- Switch off the freezer at the power outlet.
- Unplug the freezer.
- Call the Residentia Support Team on 1300 11 HELP (4357).

Some minor faults can be fixed by referring to the instructions given in the Troubleshooting section below. There is also a self-help section online at <http://www.residentiagroup.com.au>.

TROUBLESHOOTING

The following simple issues can be rectified by the user. Please contact the Residentia Support Team if the issues remain unresolved.

Issue:	Solution:
Freezer isn't operating	<ul style="list-style-type: none"> ● Check that the freezer is plugged in and connected to power. ● Check that a fuse hasn't blown or circuit tripped.
Freezer is making strange odour	<ul style="list-style-type: none"> ● Odourous foods should be closely wrapped and sealed in containers. ● Ensure that the interior is clean. Refer to cleaning instructions.
Freezer compressor is continuously running	<ul style="list-style-type: none"> ● It is normal for the freezer compressor to operate for longer periods of time when the ambient temperature is higher (ie. Summer). ● Do not put too much food in the freezer at one time. ● Do not put warm/hot foods into the freezer. ● Try to minimise the frequency of the door opening.
Illuminating light does not work	<ul style="list-style-type: none"> ● Ensure the freezer is connected to power. ● Check that the globe hasn't blown.
The Freezer door doesn't close properly	<ul style="list-style-type: none"> ● Ensure that food isn't preventing the door from closing. ● Ensure that the freezer is completely level and feet adjusted to touch the floor. ● Ensure the freezer door gaskets/seals are clean.
The freezer is making loud noises	<ul style="list-style-type: none"> ● It's normal for the freezer to make noises when refrigerant coolant is being circulated. ● Check that the refrigerator is balanced.

Technical Specifications

Gross Volume: 190L

Rated Voltage: 220V-240V, 50Hz

Net Volume: 172L

Rated Current: 1A

Refrigerant: R600a (80g)

Net Weight: 48kg

Warranty

WARRANTY TERMS AND CONDITIONS REFRIGERATION APPLIANCES

→ This document sets out the terms and conditions of the product warranties for Residentia Group Appliances. It is an important document. Please keep it with your proof of purchase documents in a safe place for future reference should you require service for your Appliance.

1. In this warranty
 - (a) 'acceptable quality' as referred to in clause 10 of this warranty has the same meaning referred to in the ACL;
 - (b) 'ACL' means Trade Practices Amendment (Australian Consumer Law) Act (No.2) 2010;
 - (c) 'Appliance' means any Residentia Group product purchased by you accompanied by this document;
 - (d) 'ASR' means Residentia Group authorised service representative;
 - (e) 'Residentia Group' means Residentia Group Pty Ltd of 20 Yaltara Avenue, Bundoora Victoria 3083, ACN 600 546 656 in respect of Appliances purchased in Australia;
 - (f) 'major failure' as referred to in clause 10 of this warranty has the same meaning referred to in the ACL and includes a situation when an Appliance cannot be repaired or it is uneconomic for Residentia Group, at its discretion, to repair an Appliance during the Warranty Period;
 - (g) 'Warranty Period' means:
 - (i) where the Appliance is used for personal, domestic or household use (i.e. normal single family use) as set out in the instruction manual, the Appliance is warranted against manufacturing defects in Australia for 12 months following the date of original purchase of the Appliance;
 - (h) 'you' means the purchaser of the Appliance not having purchased the Appliance for re-sale, and 'your' has a corresponding meaning.
2. This warranty only applies to Appliances purchased and used in Australia and is in addition to (and does not exclude, restrict, or modify in any way) any non-excludable statutory warranties in Australia.
3. During the Warranty Period Residentia Group or its ASR will, at no extra charge if your Appliance is readily accessible for service, without special equipment and subject to these terms and conditions, repair or replace any parts which it considers to be defective. Residentia Group or its ASR may use remanufactured parts to repair your Appliance. You agree that any replaced Appliances or parts become the property of Residentia Group. This warranty does not apply to light globes, batteries, filters or similar perishable parts.
4. Parts and Appliances not supplied by Residentia Group are not covered by this warranty.
5. You will bear the cost of transportation, travel and delivery of the Appliance to and from Residentia Group or its ASR. If you reside outside of the service area, you will bear the cost of:
 - (a) travel of an authorised representative;
 - (b) transportation and delivery of the Appliance to and from Residentia Group or its ASR, in all instances, unless the Appliance is transported by Residentia Group or its ASR, the Appliance is transported at the owner's cost and risk while in transit to and from Residentia Group or its ASR.
6. Proof of purchase is required before you can make a claim under this warranty.

Warranty continued

7. You may not make a claim under this warranty unless the defect claimed is due to faulty or defective parts or workmanship. Residentia Group is not liable in the following situations (which are not exhaustive):
- (a) the Appliance is damaged by:
 - (i) accident
 - (ii) misuse or abuse, including failure to properly maintain or service
 - (iii) normal wear and tear
 - (iv) power surges, electrical storm damage or incorrect power supply
 - (v) incomplete or improper installation
 - (vi) incorrect, improper or inappropriate operation
 - (vii) insect or vermin infestation
 - (viii) failure to comply with any additional instructions supplied with the Appliance;
 - (b) the Appliance is modified without authority from Residentia Group in writing;
 - (c) the Appliance's serial number or warranty seal has been removed or defaced;
 - (d) the Appliance was serviced or repaired by anyone other than Residentia Group, an authorised repairer or ASR.
8. This warranty, the contract to which it relates and the relationship between you and Residentia Group are governed by the law applicable where the Appliance was purchased.
9. To the extent permitted by law, Residentia Group excludes all warranties and liabilities (other than as contained in this document) including liability for any loss or damage whether direct or indirect arising from your purchase, use or non use of the Appliance.
10. For Appliances and services provided by Residentia Group in Australia, the Appliances come with a guarantee by Residentia Group that cannot be excluded under the Australian Consumer Law. You are entitled to a replacement or refund for a major failure and for compensation for any other reasonably foreseeable loss or damage. You are also entitled to have the Appliance repaired or replaced if the Appliance fails to be of acceptable quality and the failure does not amount to a major failure. The benefits to you given by this warranty are in addition to your other rights and remedies under a law in relation to the Appliances or services to which the warranty relates.
11. At all times during the Warranty Period, Residentia Group shall, at its discretion, determine whether repair, replacement or refund will apply if an Appliance has a valid warranty claim applicable to it.
12. To enquire about claiming under this warranty, please follow these steps:
- (a) carefully check the operating instructions, user manual and the terms of this warranty;
 - (b) have the model and serial number of the Appliance available;
 - (c) have the proof of purchase (e.g. an invoice) available;
 - (d) telephone the numbers shown below.
13. You accept that if you make a warranty claim, Residentia Group and its ASR may exchange information in relation to you to enable Residentia Group to meet its obligations under this warranty.

IMPORTANT Before calling for service, please ensure that the steps in point 12 have been followed.

Service: Please call 1300 11 HELP (4357)

Spare Parts: Please call 1300 11 SPARE (7727)

Model Code/s:

EUF172W



E2447

Residentia