

User Manual



*Self-Cleaning
Wetpour Mixer*

The Worlds #1 Self Cleaning Mega Mixer

Go Easy • GO APE
Go Fast •



**All
Preparation
Equipment**

*www.archquip.com.au
Phone: 07 3394 2724
Email: sales@archquip.com.au
Showroom: 50 Morley Street
Coorparoo Qld 4151*

INITIAL SETUP

- 1) Make sure the Rotatub mixer is up right with wheels and feet on the ground.
- 2) If you have purchased a mixer with optional extras you need to set them up before use.
 - a) Adjustable legs - legs must be adjusted to suit the terrain the mixer will be operating on. To do this you need to loosen the locking nuts (use a hammer) on the threaded shaft and adjust the feet up or down by rotating them until the mixer is as level as possible. Once you are satisfied that the mixer is level tighten locking nuts for safety.

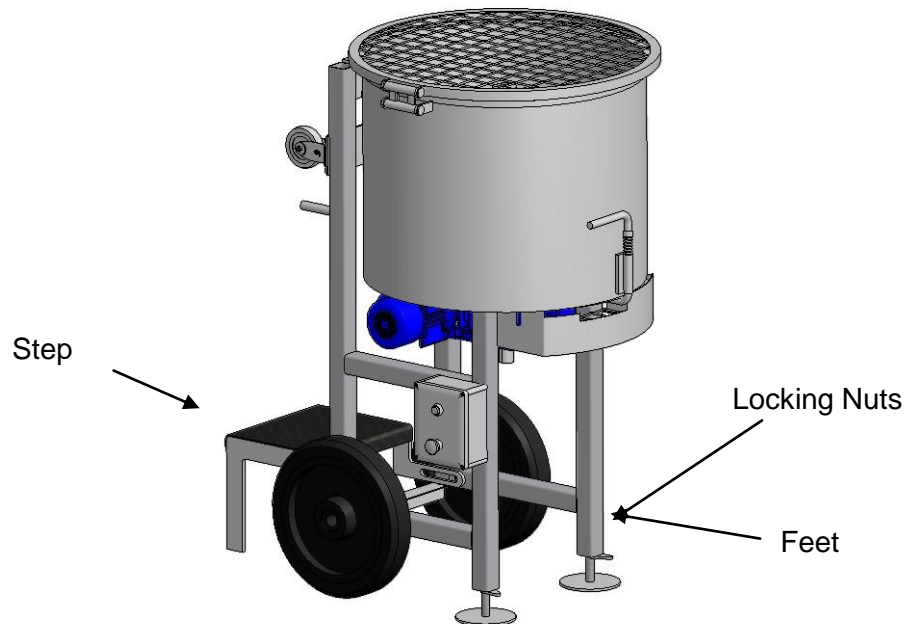

- b) Foldout Step - the step is secured with zip ties from new for safe transportation. Remove the zip tie securing step to mixer. (Take care not to remove zip ties holding crucial wiring to mixer). Fold the step over and slide out on its rails. Ensure the step is stable.
- 3) When mixing base rubber (eg. 4 mesh buffings or 8–15mm granules) replace the No.1 blade with the specially designed No.1-4 # blade to allow for big particle clearance between the blade and the discharge hole in the floor.

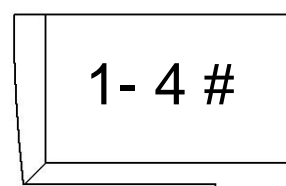
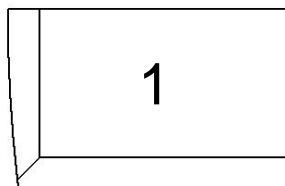

INTRODUCTION

Congratulations on the purchase of your ROTATUB wetpour mixer

The Mega Mixa has been specially designed to significantly reduce the problem resin build up that most common wetpour mixers suffer from. It is manufactured to the highest standards and constructed from selected quality materials. The unique design will give many trouble free years of operation with only the minimum amount of maintenance when used in accordance with this User Manual.

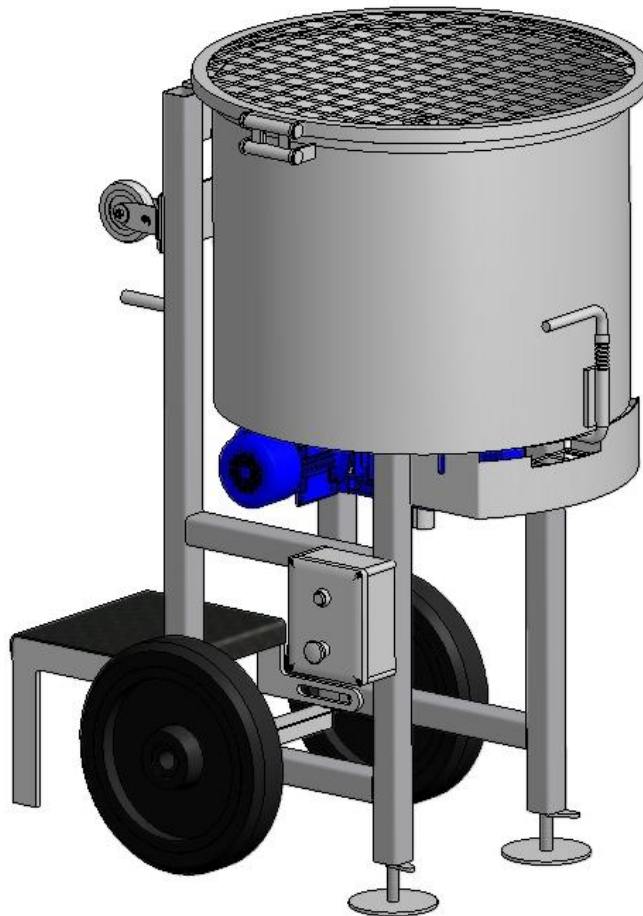

OPERATION

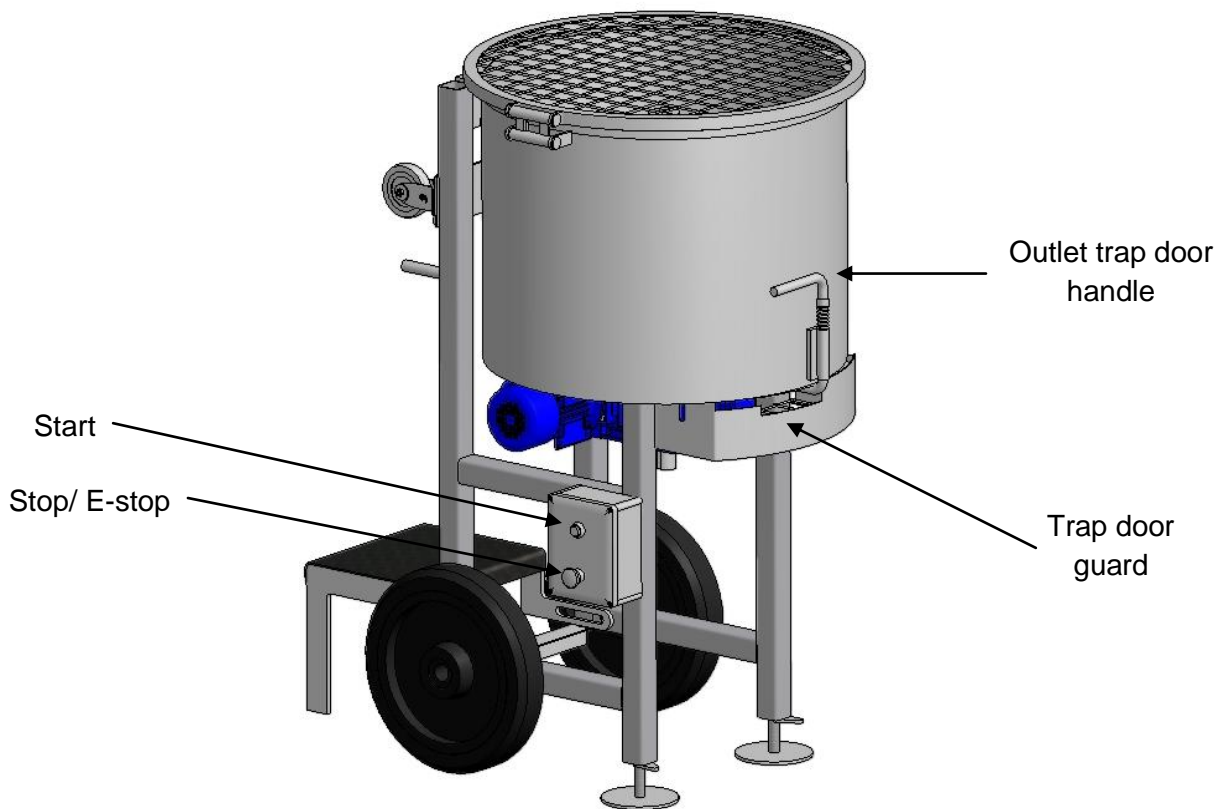

Fig 1



ALWAYS READ AND FOLLOW THE MANUFACTURERS INSTRUCTIONS OF THE PRODUCTS TO BE MIXED!

- 1) For best results add the rubber and glue products before starting the mixing blades.
- 2) Press start and once the required consistency has been achieved place a suitable container (wheelbarrow) under the outlet trap door (fig.1). The door height has been designed to fit a standard size wheelbarrow underneath.
- 3) Keep the mixer running and open the outlet trap door. The product will empty into the wheelbarrow and with the action of the spring loaded mixing blades the mixer will start to self clean.
- 4) Once the product is discharged close the outlet trap door.
- 5) The mixing blades can now be stopped and the process restarted if required.

CLEANING

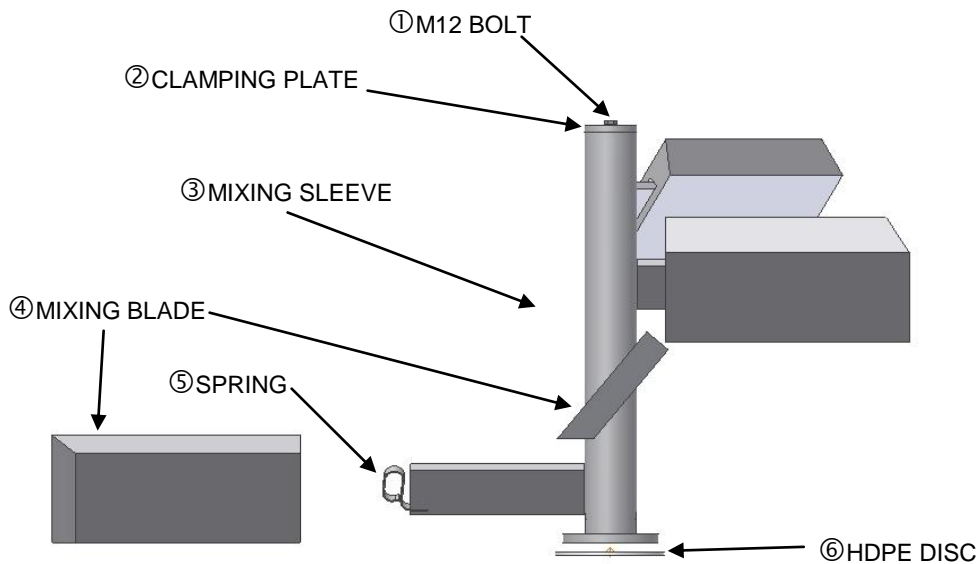

Fig. 2



ALWAYS DISCONNECT THE POWER SUPPLY BEFORE CLEANING THE DRUM



READ AND FOLLOW SAFETY INSTRUCTIONS FROM THE MANUFACTURERS OF THE PRODUCTS WHICH WERE MIXED

TO REMOVE MIXING ASSEMBLY

- 1) Remove the ①M12 bolt and ②clamping plate from the ③mixing sleeve.
- 2) Carefully lift the ③mixing sleeve upwards. As each ④mixing blade exits the mixing bowl it will move away from the centre under the pressure of the ⑤spring.

- 3) Remove the ④ mixing blades and clean the bowl and blades as desired.
- 4) Care must be taken not to damage the springs.

TO RE-ASSEMBLE MIXING ASSEMBLY

- 1) Ensure all blade slots are clean and free from debris. Grease mixer arms after every use.
- 2) Check mixer arm springs are not bent or missing.
- 3) Whilst mixing arm assembly is not fitted to the mixer, install bottom scraper blade (marked as number 1) to bottom mixer arm. Ensure the numbering on the blade is upright and to the rear in relation to the rotational direction of the mixing arms.
- 4) Install 2nd, 3rd and 4th (if applicable) numbered blades from bottom to top with the top blade being numbered 3 for Mega Mix 25 or 4 for Mega Mixa 50. All numbers to the rear of the direction of the mixing rotation.
- 5) Install the mixing arm assembly over the drive shaft and compress each blade as required to enable the assembly to slide down to the floor of the mixer.
- 6) Locate the drive shaft with the drive sockets on the bottom of the mixing arm assembly.
- 7) Always start the mixer dry to test correct operation prior to adding rubber.

PARTS

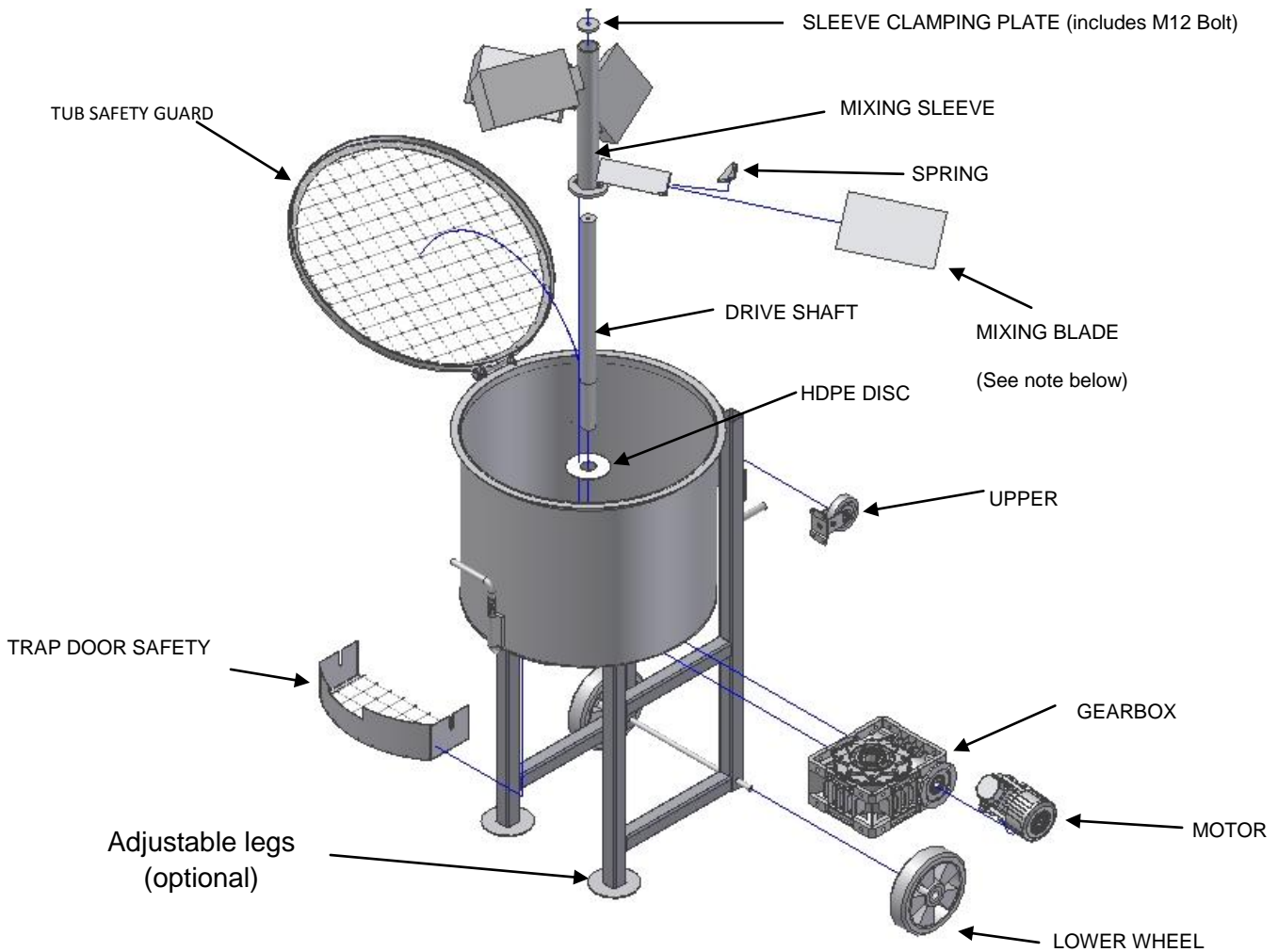

Note:

1) All mixing blades are imprinted with a number which corresponds to its position on the mixing sleeve (No. 1 being lowest on the sleeve), when ordering spare blades you must supply the blade number.

2) Always quote model and serial number when ordering spare parts.

MAINTENANCE

The Mega Mixa has been designed with minimum maintenance requirements, to keep your mixer running at optimum performance simply follow these basic steps.

	Daily	Weekly	Monthly	Comments
Check safety guards are in place	●			
Lubricate spring and mixing blade arm	●			Use general purpose grease
Check motor cover is clear	●			
Check operation of top guard interlock	●			Slowly open lid with mixer running and ensure it stops immediately
Lubricate wheel axels (4 off)		●		General purpose light oil
Lubricate top guard hinge		●		General purpose light oil
Lubricate trap door hinge		●		General purpose light oil
Check all welds			●	Visual check
Check all fasteners			●	

SPECIFICATIONS

Model	Mega Mixa 25	Mega Mixa 50
Capacity	25Kg	50Kg
Motor	1.5 Kw	1.5 Kw
Gearbox	40:1	80:1
H x W x D	1120 H x 850 W X 850 D	1380 H x 850 W x 1000 D
Mixing Blades	3	4
Power Requirements	10 amps Single Phase	10 amps Single Phase
Weight of Mixer	110kgs	135kgs
Drum Dimensions	400 H x 600 Diameter	550 H x 700 Diameter
Drum Volume - Cubic Metres	0.11m ³	0.21m ³
Drum Volume - Litres	113.1 Litres	211.6 Litres



TRAINING COMPETANCY

Archquip supports good workplace safety. Copy this page and ensure each operator of the machine has read and understands how to correctly operate the machine.

Have you read this manual in full Yes / No

Do you fully understand the instructions Yes / No

If you answer **no** to any of these questions then do not operate the mixer.

I fully understand the instructions and agree to operate the mixer in a safe manner

Sign _____

Date _____

Print Name _____

Archquip

50 Morley Street

Coorparoo Qld 4151

T: (07) 3394 2724

F: (07) 3394 3207

E: sales@archquip.com.au