



# victron energie

## USER MANUAL GEBRUIKSAANWIJZING GEBRAUCHSANWEISUNG

### ORION 24/12/20



**CONTENTS**

Page

---

<b>1. INTRODUCTION</b>	<b>5</b>
1.1 Warnings	5
<b>2. DESCRIPTION</b>	<b>6</b>
2.1 The Orion 24/12/20	6
2.3 Safety Features	6
<b>3. INSTRUCTIONS FOR USE</b>	<b>7</b>
3.1 Installation	7
3.2 Operation	8
3.3 Maintenance	8
<b>5. TROUBLESHOOTING</b>	<b>10</b>
<b>6. TECHNICAL SPECIFICATIONS</b>	<b>11</b>
6.1 Input	11
6.2 Output	11
6.3 General	11
6.4 Dimensions	12



# 1. INTRODUCTION

---

Victron Energie is internationally renowned for the design and manufacture of electrical power supply systems. This is due to the ongoing attention devoted by the R&D Department to product research and the use of new technologies in its products.

Victron Energie systems provide high-quality power supplies in locations where there is no permanent connection to the electricity mains. A stand-alone automatic power supply system can consist of: a Victron Energie converter, a Victron Energie battery charger, if necessary a Victron Energie Mains Manager and batteries with sufficient capacity.

This manual describes the installation, functionality and use of the Orion 24/12/20 DC-DC converter, including safety features.

## 1.1 Warnings



The Orion housing should only be opened by a qualified electrical engineer. The Orion must be disconnected from the battery before the housing is opened.



Explosive gases may arise during charging of a lead-acid battery. Avoid naked flames and sparks. Ensure adequate ventilation during charging.



The components on the Orion printed circuit board may be under voltage.



The Orion may not be used to recharge non-rechargeable batteries.



The Orion is NOT protected against polarity reversal of the connected battery (“+” connected to “-” and “-” connected to “+”). Follow the recommended connection procedure. The factory guarantee is void if a fault is caused to the Orion due to polarity reversal.

## 2. DESCRIPTION

---

### 2.1 The Orion 24/12/20

The Orion 24/12/20 is a DC-DC converter. This means that the Orion converts a DC voltage of 24 V into a stable DC voltage of 13.6 V. This voltage is suitable for supplying a 12 V system. The maximum current which can be supplied by the Orion is 20A. The Orion can also be used as a charger for charging a 12 Volt battery. Note that the maximum voltage is 13.6 V on the 12 V battery; the Orion does not have 3-stage charging, as Pallas chargers do.

The Orion has a robust aluminium housing, and can be floor- or wall-mounted.

### 2.3 Safety Features

The Orion is extremely reliable thanks to its built-in safety features, which are explained in greater detail below. See the technical specifications in Chapter 6 for the exact values.

The current supplied by the Orion is limited to 20 Ampères. This limit is set in the factory.

The Orion output is protected against short-circuit. When the output is short-circuited, the output voltage of the Orion drops to virtually 0 Volts. As soon as the short circuit is eliminated, the Orion returns to operation immediately.

The Orion input is protected by a fuse.

The Orion shuts down automatically when the voltage at the 24 V input is too low, and switches back on as soon as the input voltage has risen sufficiently again.

The Orion shuts down automatically when the voltage at the 24 V input is too high, and switches back on as soon as the input voltage has fallen sufficiently again.

The Orion output is fitted with a fuse.

The internal temperature of the Orion is continuously monitored. If the temperature of the Orion rises to an excessively high level, the Orion shuts down automatically. As soon as the temperature has fallen sufficiently, the Orion starts up again.



## 3. INSTRUCTIONS FOR USE

### 3.1 Installation

Place the Orion and the battery in a dry, well-ventilated area.

Fix the Orion to the wall or floor. Under high ambient temperature conditions, it is recommended that the Orion be fixed to a wall to ensure better cooling and a longer life. See the drawing in Chapter 6 for the dimensions of the Orion and the location of the fixing holes.

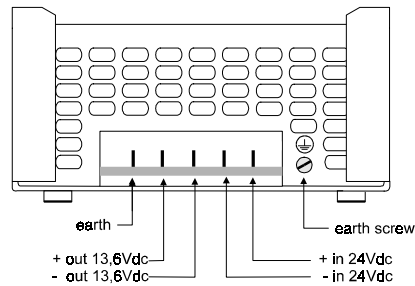

Figure 1.  
Position of Orion  
connections.

#### Connecting the earth

The Orion earth connection must be connected to a genuine earthing point and must comply with the applicable safety requirements.

- Where the device is used on a boat, the earth connection or the earth screw must be connected to the earth plate or the ship's hull.
- In mobile applications (car, caravan, etc.) the earth connection or the earth screw must be connected to the chassis of the car, caravan, etc.

#### Connecting the output

12 V electrical loads or a battery can be connected to the Orion output. When connecting 12 V electrical loads, take care to ensure the correct polarity (connect “+” to “+” and “-” to “-”).

When a battery is connected to the output:

- First connect the positive battery terminal to the “+ out” connection on the Orion.
- Then connect the negative battery terminal to the “- out” connection on the Orion.

cable length	cable diameter
up to 1.5 meters	2.5 mm <sup>2</sup>
between 1.5 en 6 meters	6 mm <sup>2</sup>

### Connecting a battery to the input

A good connection between the Orion and the battery is essential. The cables used should therefore be as short and as thick as possible to minimise voltage loss between the Orion and the battery. The shorter and thicker the cables, the lower their resistance.

Cables longer than 6 meters in length are not recommended. The table below shows the recommended minimum cross-sections for the copper core of the battery cables.

cable length	cable diameter
up to 1.5 meters	2.5 mm <sup>2</sup>
between 1.5 and 6 meters	6 mm <sup>2</sup>

The Orion must be connected to the battery as follows:

- First connect the positive battery terminal to the “+ in” connection on the Orion.
- Then connect the negative battery terminal to the “- in” connection on the Orion.

When removing from the Orion, the negative battery terminal must be disconnected first, and then the positive battery terminal.

 CAUTION	The Orion is NOT protected against polarity reversal of the connected battery (“+” connected to “-” and “-” connected to “+”). Follow the recommended connection procedure. The factory guarantee is void if a fault is caused to the Orion due to polarity reversal.
--	---

### 3.2 Operation

The Orion comes into operation as soon as it is connected in the correct manner, and as soon as the 24 V input voltage is present.

### 3.3 Maintenance

The Orion requires no specific maintenance. However, annual inspection of the battery connections is recommended.

The Orion should be kept dry, clean and dust-free. In the event of any problems, the fault can be traced using the troubleshooting diagram in Chapter 5 of this manual.

## 4. OPTIONS

The Orion is set to the standard settings and adjusted in the factory. The standard output voltage of the Orion is a stable voltage of 13.6 Volts. However, the output voltage can be modified so that the output voltage is half the input voltage. This setting should only be changed by a qualified electrical engineer.

The procedure is as follows:

- Remove the battery on the input, or switch the battery off.
- Wait two minutes.
- Remove the four outer screws on the side of the casing.
- Then remove the cover (see Figure 2).
- Move the jumper as shown in Figure 3.

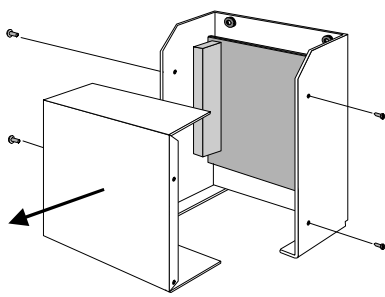

Figure 2.  
Opening the housing.

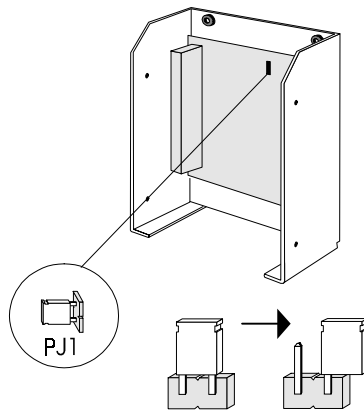

Figure 3.  
The Jumper.



The Orion housing should only be opened by a qualified electrical engineer. The battery connected to the input of the Orion must be removed before the housing is opened.



The components on the Orion printed circuit board may be under voltage.

## 5. TROUBLESHOOTING

---

In the event of a fault, certain points can be checked. Before carrying out checks on the Orion, all equipment connected to the output of the Orion must be disconnected. If the fault cannot be corrected, consult your Victron Energie dealer.

Problem	Possible cause	Solution
Orion does not operate	The input voltage value must lie between 18Vdc and 30Vdc.	Measure the input voltage and ensure that it lies between 18Vdc and 30Vdc.
	The input fuse is defective.	Replace the fuse
	The output fuse is defective.	Replace the fuse



WARNING

The Orion housing should only be opened by a qualified electrical engineer. The battery connected to the input of the Orion must be removed before the housing is opened.







## 6.4 Dimensions

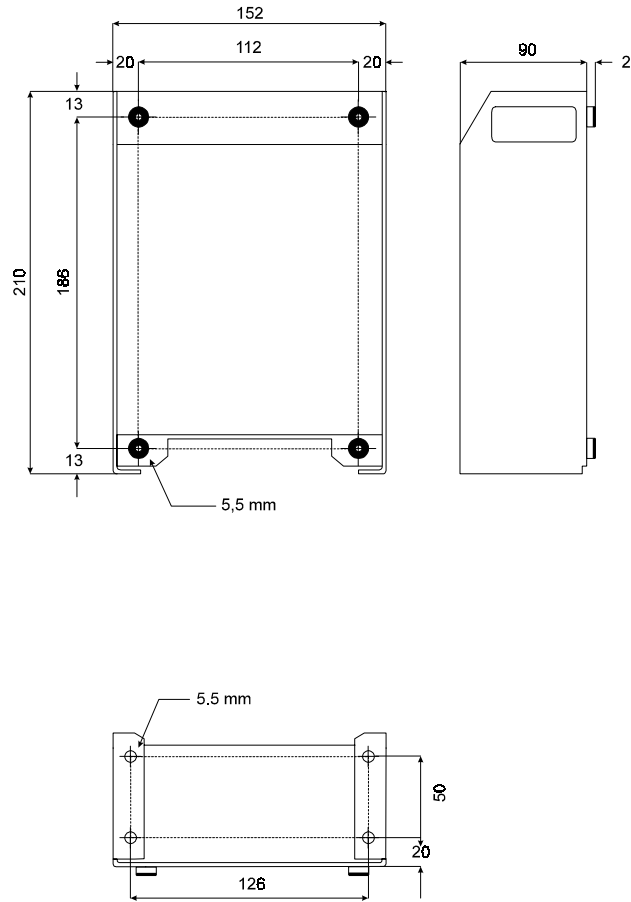

© Victron Energie b.v.

Orion 24/12/20 dimensions

Drawing: OR010006  
date: 110898  
revision: 0001