

5-port 10/100BaseTX Industrial Switch

User Manual

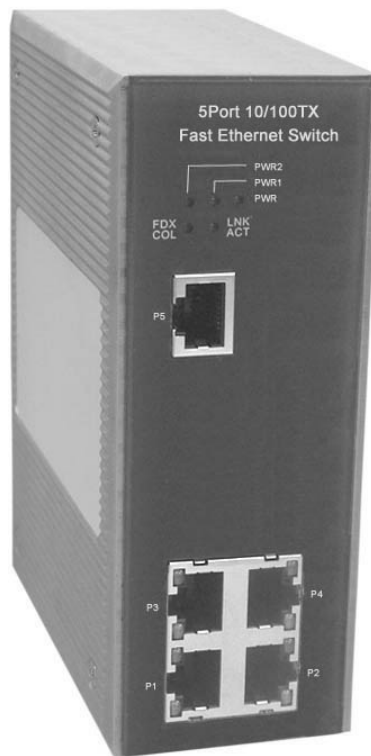

Rev.1.00
08-August-2005

Content

Introduction.....	1
Features	1
Package Contents.....	1
Hardware Description	3
Physical Dimension.....	3
Front Panel.....	3
Bottom View	4
Wiring the Power Inputs	4
LED Indicators.....	5
Ports	6
Cabling	8
Mounting Installation	9
DIN-Rail Mounting.....	9
Wall Mount Plate Mounting	11
Hardware Installation.....	12
Installation Steps.....	12
Troubles shooting	14

Technical Specification.....	15
------------------------------	----

Introduction

The 5-port 10/100BaseTX Industrial Switch is a cost-effective solution and meets the high reliability requirements demanded by industrial applications. It provides the redundant power inputs that prevent the power failure.

Features

- 5-port 10/100TX industrial switch
- Store-and-Forward switching architecture
- Conforms to IEEE 802.3 10Base-T, 802.3u 100Base-TX
- RJ-45 port support auto MDI/MDI-X function
- 512Kbytes Embedded memory
- IEEE 802.3x flow control support
 - Flow control on full-duplex
 - Back pressure on half-duplex
- Wide-range redundant power design
- 1K MAC address table
- DIN rail and wall mount design
- Meets IP-30 case protection

Package Contents

Please refer to the package content list below to verify them against the checklist.

- 5-port 10/100BaseTX Industrial Switch
- One DIN-Rail (screwed on the switch)
- One wall mount plate and six screws

■ User manual



5-port 10/100TX industrial switch



User Manual



Wall Mount Plate



Screws

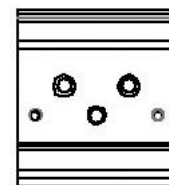
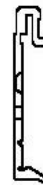

DIN-Rail

Compare the contents of your industrial switch with the standard checklist above. If any item is damaged or missing, please contact your local dealer for service.

Hardware Description

In this paragraph, we will introduce the Industrial switch's hardware spec, port, cabling information, and wiring installation.

Physical Dimension

5-port 10/100BaseTX Industrial Switch dimension (W x H x D) is **54mm x 135mm x 105mm**

Front Panel

The Front Panel of the 5-port 10/100BaseTX Industrial Switch is showed as following figure.

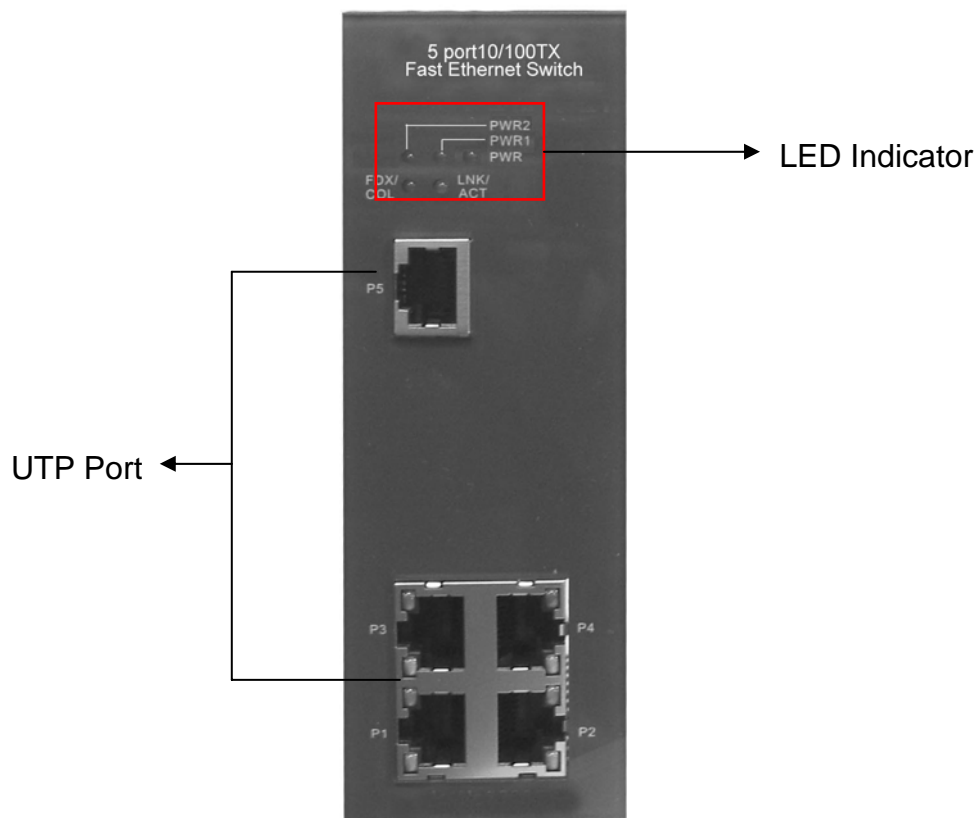

Figure A. Front Panel of the 5-port 10/100BaseTX Industrial Switch

Bottom View

The bottom panel of the 5-port 10/100BaseTX Industrial Switch consists one terminal block connector within two DC power inputs and one DC IN power jack for extra AC/DC power adapter.

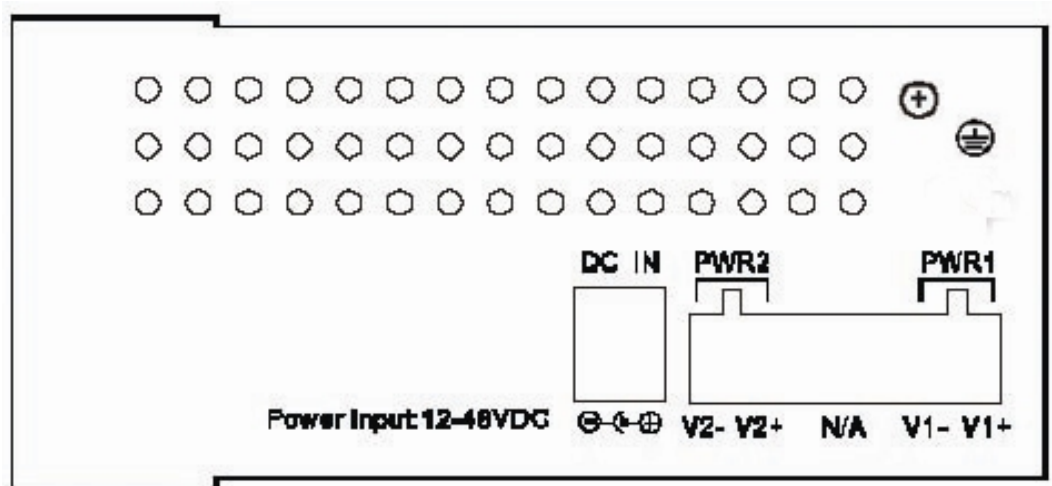
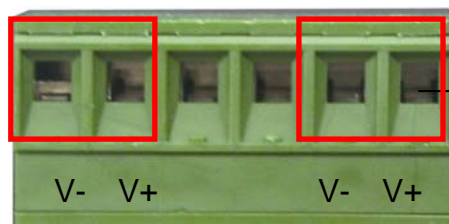

Figure B. Bottom Panel of the 5-port 10/100BaseTX Industrial Switch

Wiring the Power Inputs

Please follow below steps to insert the power wire.



1. Insert the positive and negative wires into the V+ and V- connector on the terminal block connector.

[Note] The wire range of terminal block is from 12~24AWG.

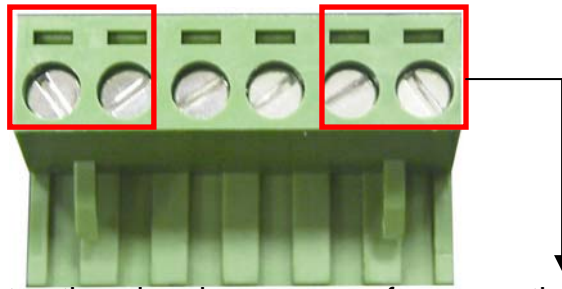

2. To tighten the wire-clamp screws for preventing the DC wires to loose.

LED Indicators

There are several diagnostic LEDs located on the Front panel of the industrial switch. They provide real-time information of system and optional status. The following table provides description of the LED status and their meanings for the switch.

LED	Status	Meaning
Power	Green	When the industrial switch has power input s the LED will light on
	Off	No any power inputs
Power 1	Green	Power on
	Off	No power inputs
Power 2	Green	Power on
	Off	No power inputs
LNK/ACT(Port 5)	Green	The port is linking with its link partner
	Blinks	The port is transmitting or receiving packets from the TX device.
	Off	No device attached

FDX/COL (Port 5)	Orange	The port is operating in full-duplex mode.
	Blinks	Collision of Packets occurs in the port.
	Off	The port in half-duplex mode or no device attached
Port 1 ~ 4 LED Indicator	Orange	The port is operating in full-duplex mode.
	Blinking (Orange)	Collision of Packets occurs.
	Off	The port is in half-duplex mode or no device is attached.
	Green	A network device is detected.
	Blinking (Green)	The port is transmitting or receiving packets from the TX device.
	Off	No device is attached.

Ports

RJ-45 ports (Auto MDI/MDIX): 5x 10/100Mbps auto-sensing port for 10Base-T or 100Base-TX devices connection. The UTP ports will auto-sense for 10Base-T or 100Base-TX connections. Auto MDI/MDIX means that you can connect to another switch or workstation without changing straight through or crossover cabling. See Figure C and C-1 for straight through and crossover cable schematic.

■ **RJ-45 Pin Assignments**

Pin Number	Assignment
1	Tx+
2	Tx-
3	Rx+
6	Rx-

Table 1

Note: “+” and “-” signs represent the polarity of the wires that make up each wire pair.

All ports on this industrial switch support automatic MDI/MDI-X operation, you can use straight-through cables (See Figure below) for all network connections to PCs or servers, or to other switches or hubs. In straight-through cable, pins 1, 2, 3, and 6, at one end of the cable, are connected straight through to pins 1, 2, 3 and 6 at the other end of the cable. The table below shows the 10BASE-T/ 100BASE-TX MDI and MDI-X port pin outs.

Pin MDI-X	Signal Name	MDI Signal Name
1	Receive Data plus (RD+)	Transmit Data plus (TD+)
2	Receive Data minus (RD-)	Transmit Data minus (TD-)
3	Transmit Data plus (TD+)	Receive Data plus (RD+)
6	Transmit Data minus (TD-)	Receive Data minus (RD-)

Table 2

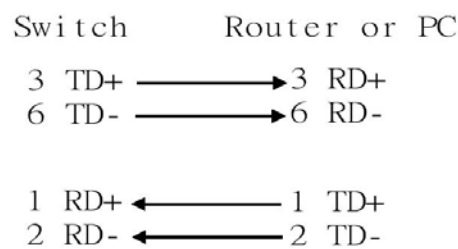

Straight Through Cable Schematic
Configure C

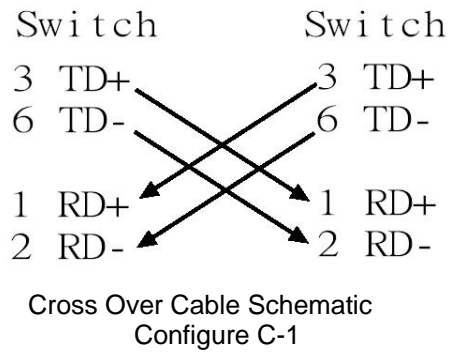

Cabling

Using four twisted-pair, Category 5 cabling for RJ-45 port connection. The cable between the converter and the link partner (switch, hub, workstation, etc.) must be less than 100 meters (328 ft.) long.

Mounting Installation

DIN-Rail Mounting

The DIN-Rail is screwed on the industrial switch when out of factory. If the DIN-Rail is not screwed on the industrial switch, please see the following figure to screw the DIN-Rail on the switch. To hang the industrial switch, follow the below steps.

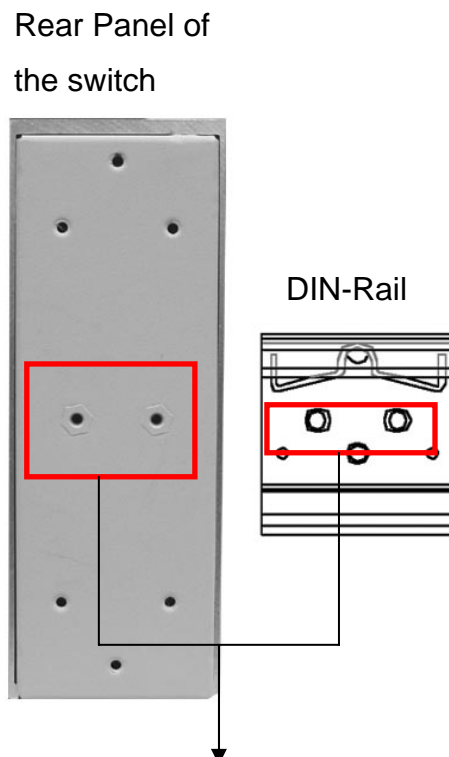

1. Use the screws to screw on the DIN-Rail on the industrial switch
2. To remove the DIN-Rail, reverse the step 1.

1. First, insert the top of DIN-Rail into the track.

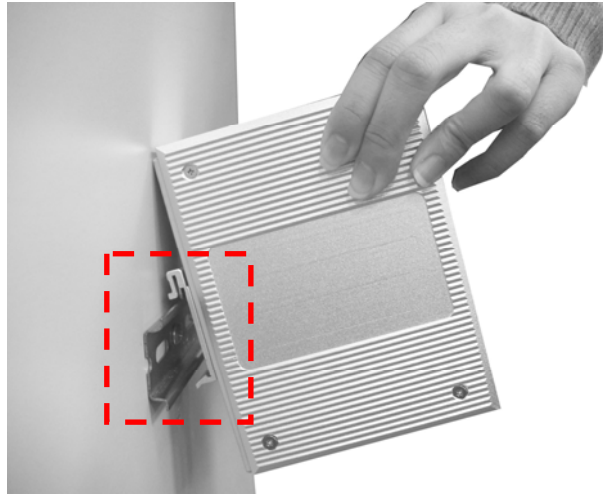

2. Then, lightly push the button of DIN-Rail into the track.

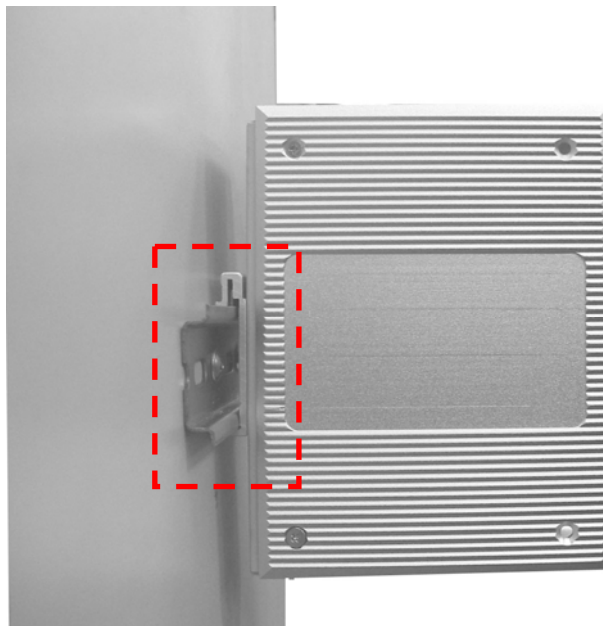

3. Check the DIN-Rail is tightly on the track.
4. To remove the industrial switch from the track, reverse steps above.

Wall Mount Plate Mounting

Follow the below steps to mount the industrial switch with wall mount plate.

1. Remove the DIN-Rail from the industrial switch; loose the screws to remove the DIN-Rail.
2. Place the wall mount plate on the rear panel of the industrial switch.
3. Use the screws to screw the wall mount plate on the industrial switch.
4. Use the hook holes at the corners of the wall mount plate to hang the industrial switch on the wall.
5. To remove the wall mount plate, reverse steps above.

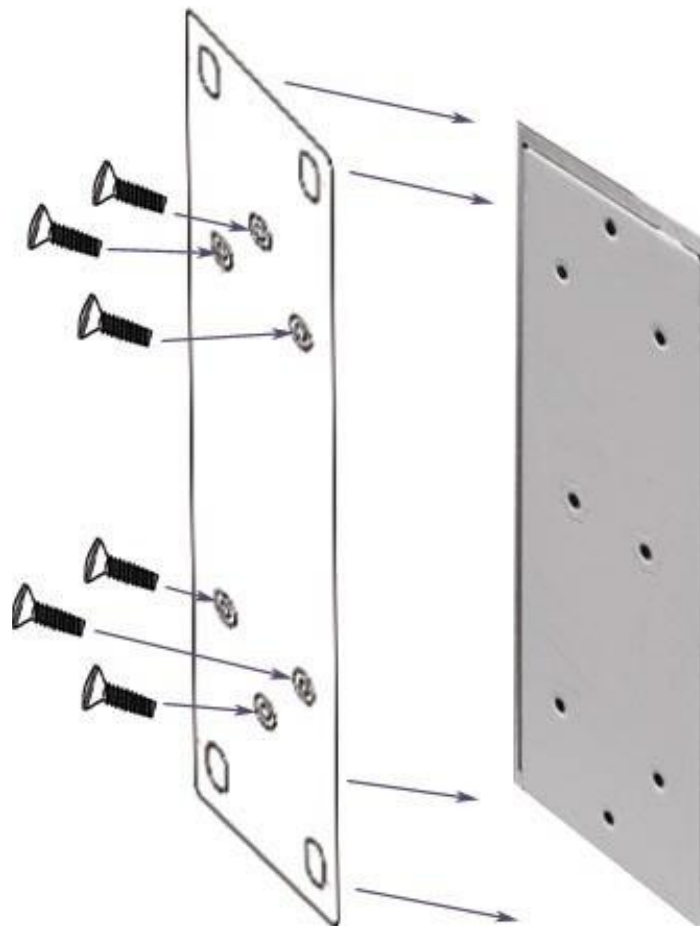

Screws to screw the wall mount plate on the Industrial media converter

Hardware Installation

In this paragraph, we will describe how to install the 5-port 10/100Base-TX Industrial Switch and the installation points for the attention.

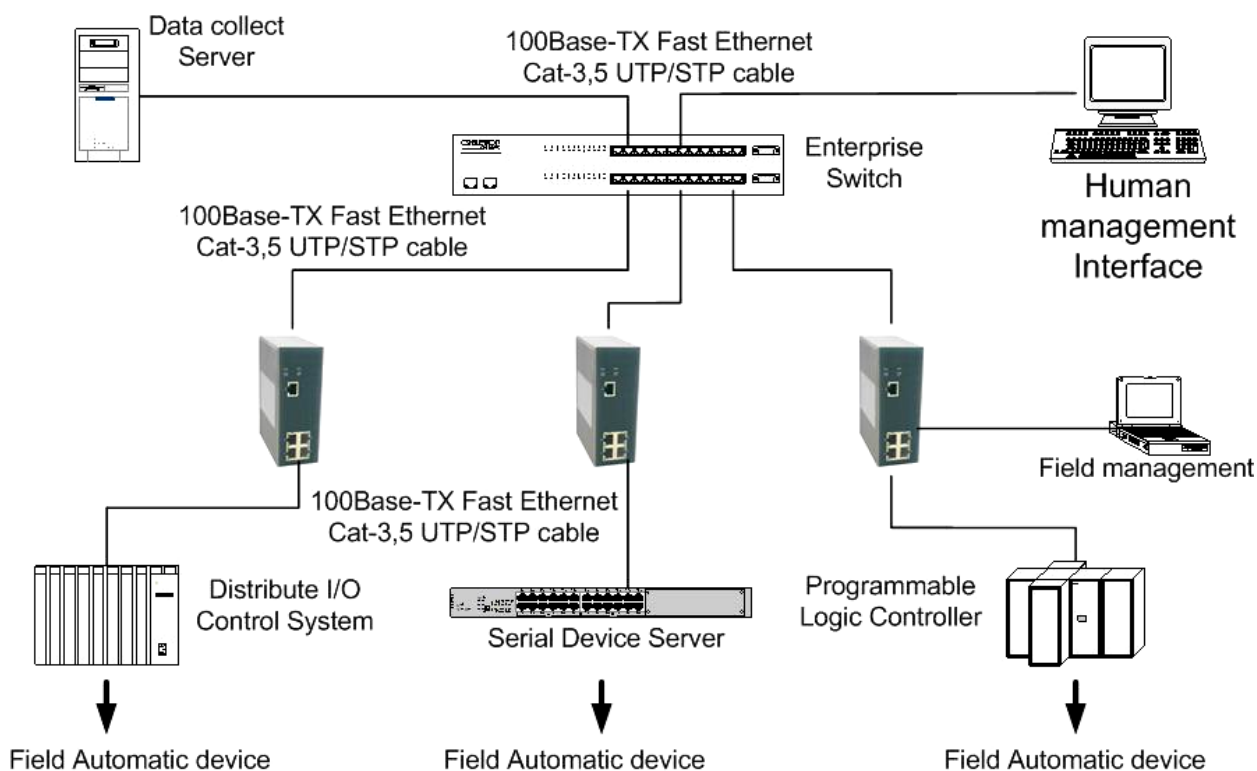

Installation Steps

1. Unpacked the Industrial switch.
2. Check the DIN-Rail is screwed on the Industrial switch. If the DIN-Rail is not screwed on the Industrial switch. Please refer to **DIN-Rail Mounting** section for DIN-Rail installation. If you want to wall mount the Industrial switch, then please refer to **Wall Mount Plate Mounting** section for wall mount plate installation.
3. To hang the Industrial switch on the DIN-Rail track or wall, please refer to the **Mounting Installation** section.
4. Power on the Industrial switch. How to wire the power; please refer to

the **Wiring the Power Inputs** section. The power LED on the Industrial switch will light up. Please refer to the **LED Indicators** section for meaning of LED lights.

5. Prepare the twisted-pair, straight through Category 5 cable for Ethernet connection.
6. Insert one side of Category 5 cables into the Industrial switch Ethernet port (RJ-45 port) and another side of category 5 cables to the network devices' Ethernet port (RJ-45 port), ex: switch, Pc or Server. The UTP port (RJ-45) LED on the Industrial switch will light up when the cable connected with the network device. Please refer to the **LED Indicators** section for LED light meaning.

[Note] Be sure the connected network devices support MDI/MDI-X. If it does not support then use the crossover category 5 cable.

7. When all connections are all set and LED lights all show in normal, the installation is complete.

Troubles shooting

- Verify that you are using the right power cord/adapter (DC 12-48V), please don't use the power adapter with DC output bigger than 48V, or it will burn this converter down.
- Select the proper UTP able to construct your network. Please check that you are using the right cable. use unshielded twisted-pair (UTP) or shield twisted-pair (STP) cable for RJ-45 connections: 100 Ω Category 3, 4 or 5 cable for 10Mbps connections or 100 Ω Category 5 cable for 100Mbps connections. Also be sure that the length of any twisted-pair connection does not exceed 100 meters (328 feet).
- **Diagnosing LED Indicators:** the Switch can be easily monitored through panel indicators to assist in identifying problems, which describes common problems you may encounter and where you can find possible solutions.
- IF the power indicator does not turn on when the power cord is plugged in, you may have a problem with power cord. Than check for loose power connections, power losses or surges at power outlet. IF you still cannot resolve the problem, contact your local dealer for assistance.
- If the Industrial switch LED indicators are normal and the connected cables are correct and the packets still cannot transmit. Please check your system's Ethernet devices' configuration or status.

Technical Specification

5-port 10/100BaseTX Industrial Switch technical specification is following.

Standard	IEEE 802.3 10Base-T Ethernet IEEE 802.3u 100Base-TX Fast Ethernet IEEE802.3x Flow Control and Back-pressure
Protocol	CSMA/CD
Technology	Store and Forward
Transfer Rate	14,880 pps for Ethernet port and 148,800 pps for Fast Ethernet port
MAC address	1K MAC address table
Memory Buffer	512Kbits
LED	<ul style="list-style-type: none"> ■ Per port: Link/Activity (Green) Full duplex/Collision (Orange) ■ Per unit: Power(Green), Power 1(Green),Power 2(Green)
Network Cable	<p>10Base-T: 2-pair UTP/STP Cat. 3, 4, 5 cable EIA/TIA-568 100-ohm (100m)</p> <p>100Base-TX: 2-pair UTP/STP Cat. 5 cable EIA/TIA-568 100-ohm (100m)</p>
Back-plane	1.0 Gbps

Power Supply	12 ~48 VDC, Redundant power with polarity reverse protect function and connective removable terminal block for master and slave power.
Power consumption	2.8 Watts
Packet throughput ability	0.74Mpps @64bytes (5TX)
Install	Provides DIN rail kit and wall mount ear for 3-way install
Operation Temperature	0°C to 60°C (32°F to 140°F)
Operation Humidity	5% to 95% (Non-condensing)
Storage Temperature	-40 to 85°C
Ambient Relative Humidity	5 to 90%(non-condensing)
Dimension	IP-30, 54 mm (W) x 135 mm (H) x 105mm (D)
EMI	FCC Class A, CE EN6100-4-2, CE EN6100-4-3, CE EN-6100-4-4, CE EN6100-4-5, CE EN6100-4-6
Safety	UL, cUL, CE/EN60950
Stability testing	IEC60068-2-32 (Free fall), IEC60068-2-27 (Shock), IEC60068-2-6 (Vibration)