

# Remote Monitor PTE0700

SECURITY ELECTRONICS



## *User Manual*

## *PTE0700 V2 Series Remote Monitor*

Electronic Design & Manufacture



# 1.0 Table of Contents

1.0	TABLE OF CONTENTS.....	2
2.0	LIST OF TABLES .....	3
3.0	LIST OF FIGURES.....	4
4.0	DESCRIPTION .....	5
5.0	FEATURES .....	6
	Explanation of some terms used in this section .....	7
6.0	SPECIFICATIONS .....	9
7.0	INSTALLATION .....	10
	Hardware installation .....	10
	Output Connections .....	10
	Stand Alone Operation.....	11
	Alarm Panel Operation.....	11
	Solar Panel Operation .....	12
	Low Fence Voltage Set Point Calibration – Automatic set point.....	12
	Low Fence Voltage Set Point Calibration – Manual set point.....	12
	Delay Calibration – automatic and manual low fence voltage alarm set point. ....	13
8.0	ELECTRIC FENCE MONITOR OUTPUTS.....	14
	LED Visual Display .....	14
	Relay Output .....	14
	0-5V Analog Output .....	15
	4-20mA Analog Output.....	15
	RS232 Output.....	15
	Optional Display Board.....	17
9.0	WARRANTY.....	18

## 2.0 List of Tables

Table 1 – Model Features.....	6
Table 2 – Specifications.....	9
Table 3 – Relay Connections.....	14
Table 4 – PTE0700 RS232 Connections .....	15

## 3.0 List of Figures

Figure 1 - Output Terminal Locations.....	10
Figure 2 - Stand Alone Operation .....	11
Figure 3 - Alarm Panel Operation.....	11
Figure 4 – Solar Panel Operation.....	12
Figure 5 – PAE036 LCD Expansion PCB.....	17

## 4.0 Description

The PTE0700 Electric Fence Monitor Series are low cost electric fence monitors designed primarily for remote monitoring applications. While monitoring an electric fence for low voltage conditions, they also enable system designers to include electric fence voltages as inputs into remote telemetry or SCADA systems.

This series consists of four models, the PTE0700, 701, 702 and 703. The features of the various models can be found in the Features section of this document. The PTE0700 series can also be customised to meet your own requirements for quantity purchases.

### **Suitable Applications for the PTE0700 Series**

- Rural - pastoral stations
- Security fences
- Vermin control fences
- Zoo and sanctuary enclosures

## 5.0 Features

The various models within this range have the following features.

	PTE0700	PTE0701	PTE0702	PTE0703
<b>Inputs / Outputs</b>				
Directly connects to 10kV electric fence with high voltage inputs	✓	✓	✓	✓
Shows working fence with Green Pulse LED	✓	✓	✓	✓
Shows failing fence with Red Low Voltage LED	✓	✓	✓	✓
Alarms failing fence with internal beeper	✓	✓		✓
Alarms failing fence by setting a relay	✓	✓		✓
Alarms failing fence by setting a failsafe relay			✓	
Current output 4-20mA proportional to 0-10kV input.	✓			
Voltage output 0-5V proportional to 0-10kV input.	✓			
Simple RS-232 Data Output		✓	✓	
SCADA friendly RS-232 Data Output				✓
<b>Hardware</b>				
IP65 weather proof wall mountable enclosure	✓	✓	✓	✓
12V DC Powered	✓	✓	✓	✓
<b>Adjustment</b>				
Low Fence Voltage alarm set point or automatic self-setting	✓	✓	✓	✓
Adjustable delay from Low Fence Voltage to firing alarm	✓	✓	✓	✓
<b>Other Features</b>				
Very low current consumption	✓	✓	✓	✓
10kV Opto-Isolation from fence inputs	✓	✓	✓	✓
Expansion socket for optional LCD Display	✓	✓	✓	✓
Connects directly to 12V/2W solar panel to charge battery.	✓	✓	✓	✓

Table 1 – Model Features

## Explanation of some terms used in this section

- **Low Fence Voltage Alarm set point** is the fence voltage above which the Electric Fence Monitor will show a working fence and below which the Electric Fence Monitor will show a failing fence.

The PTE0700 series Electric Fence Monitors allow you to manually adjust this set point, or alternatively they can be set to automatically adjust this set point.

When automatically adjusting, it also 'follows' the fence's performance. If, for example, the fence were operating at 7kV when the Electric Fence Monitor is switched on, it would set its Low Fence Voltage Alarm set point at about 6kV. As days go by, grass might build up on the electric fence, lowering the voltage on the fence, or a dry spell might slowly increase the voltage on the fence. The Electric Fence Monitor sees the gradual change and adjusts its set point accordingly. If, however, the fence voltage drops more quickly the Electric Fence Monitor will raise an alarm. False alarms are less likely to be raised if the Electric Fence Monitor is allowed to automatically adjust its set point. Another advantage of using auto-adjustment is that the Monitor will also alarm on a quickly rising voltage.

- **Adjustable Delay from Low Fence Voltage to firing alarm** is the adjustable amount of time the Electric Fence Monitor waits after the fence fails before it raises an alarm. For example, If the delay is set to six seconds, and the fence voltage goes low for only three seconds, no alarm is raised. The alarm would only be raised if the fence voltage stayed below the Low Fence Voltage Alarm set point for more than six seconds.
- **Alarms failing fence with internal beeper** means that a small siren contained within the Electric Fence Monitor will sound when the fence voltage goes below the Low Fence Voltage Alarm Set Point.
- **Alarms failing fence by setting relay** there is one relay inside the Electric Fence Monitor, with three terminals, discussed fully in Section 0.0 "Relay Output" below.
- **12vDC powered** means that the Electric Fence Monitor is powered by any nominal twelve-volt supply such as a mains plug pack or battery.
- **10kV opto isolation from fence inputs** means that the fence inputs are not electrically connected to the rest of the circuitry. Instead, they are connected optically. This means that all accessories connected to the Electric Fence Monitor and the Electric Fence Monitor itself are protected from excessive voltages on the fence.
- **Current output 4-20mA proportional to 0-10kV input** means that the Electric Fence Monitor can supply an industry standard analogue signal to other equipment such as SCADA or Telemetry RTU.

- **Voltage output 0-5V proportional to 0-10kV input** as above for voltage analogue inputs.
- **RS232 output** means that the data collected by the Electric Fence Monitor can be transmitted to other equipment in RS232 format. The serial port found on most computers uses the RS232 format. You can easily use a computer to collect, save and display this information.



## 6.0 Specifications

Specification Name	Specification
Supply voltage	10-18V DC
Supply current	6mA (20mA with relay on)
Solar Panel (optional)	12V/2W (use with 12V lead acid battery)
Min measurable input voltage	0.3 kV
Input voltage measurement	Peak to peak
Relay output	Dry changeover contacts 30V 1A (<500mA recommended)
Energiser compatibility	Compatible with Low impedance energisers that meet AS3350.2.76 or IEC60335.2.76
Max 4-20mA loop excitation voltage	Supply Voltage + 0.7V.
Accuracy	±5% (design target)
Drift	less then 1% over temperature range
Temperature range	-5 to +50°C

**Table 2 – Specifications**

## 7.0 Installation

### Hardware installation

- Remove the 4 screws holding the top cover in place.
- Secure the PTE0700 to the wall or mounting device using the 4 mounting holes that will be hidden after the lid is replaced.
- Thread the 12-volt supply and any output leads into the Electric Fence Monitor enclosure through the cable gland on the side; be sure to tighten it to stop water or ants from entering.
- Attach a suitable insulated cable from the Electric Fence Monitor's red input binding post to the electric fence, and from the Electric Fence Monitor's green input binding post to a good earth connection. If possible, it is best to connect to the same earth that your energiser is using.

### Output Connections

The Electric Fence Monitor's Output Connections are visible on the bottom edge of the circuit board and consist of a row of pluggable screw terminals. In Figure 1 the screw terminals, adjustment trimmers and LED's can be seen. They will be referred to in the remainder of this document.

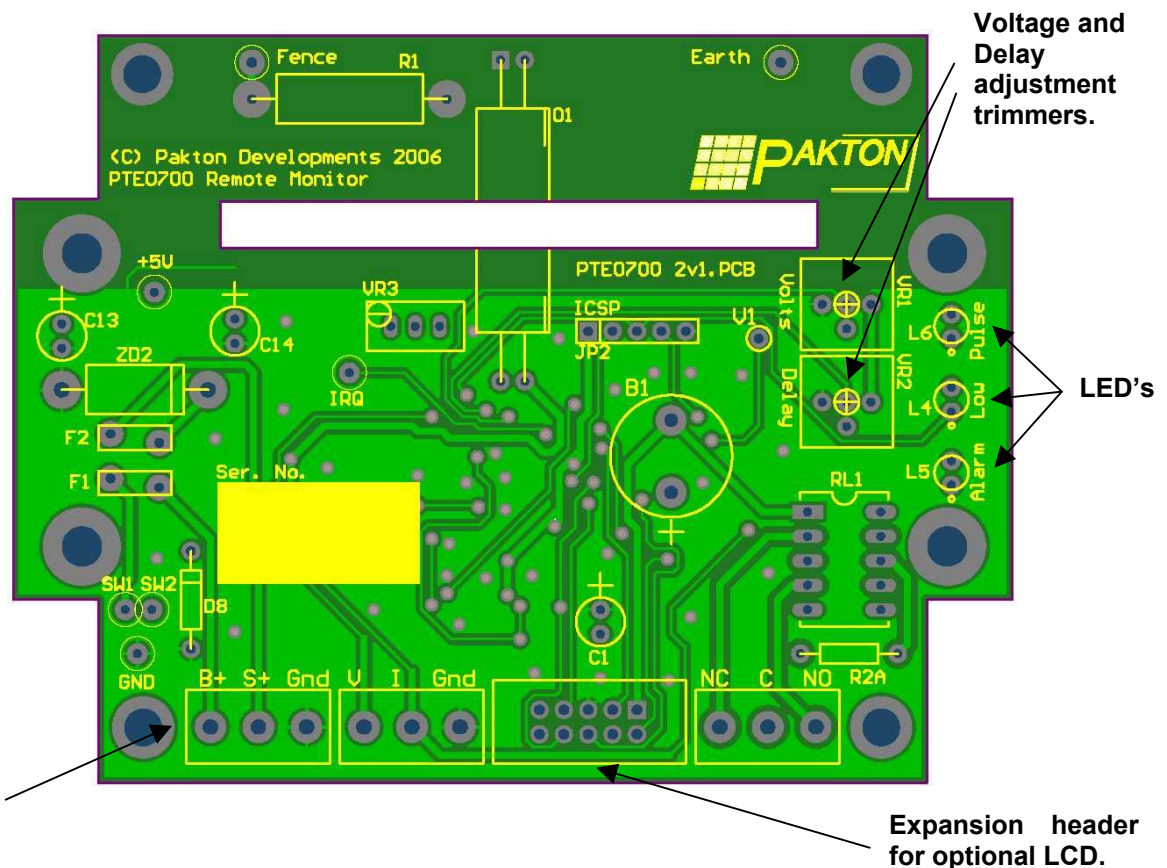

Output terminals along bottom edge of PCB.

Figure 1 - Output Terminal Locations

Expansion header for optional LCD.

The cables shown should enter the enclosure of the Electric Fence Monitor through the cable gland on the side. The connections to the electric fence are not shown in Figure 1 because those cables are terminated at the binding posts outside the Electric Fence Monitor's enclosure.

For security applications the Electric Fence Monitor can be configured for either Stand Alone or Alarm Panel Operation.

### Stand Alone Operation

In Stand Alone Operation, the relay outputs can be used to switch a siren on when an alarm condition is raised.

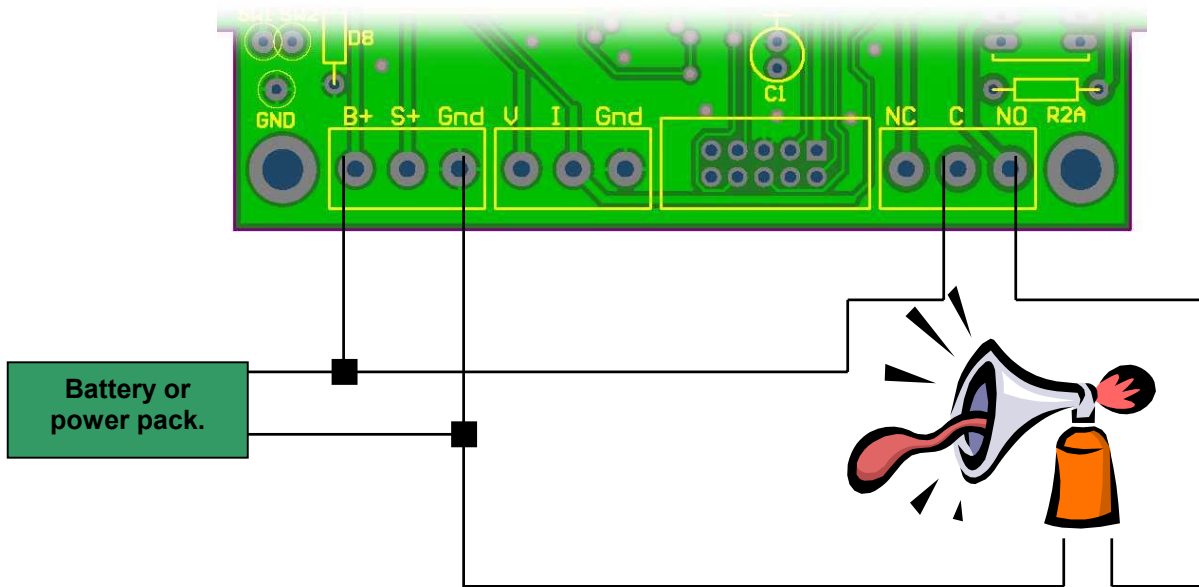

Figure 2 - Stand Alone Operation

### Alarm Panel Operation

In Alarm Panel Operation, the relay outputs are connected to the alarm panel. See the documentation supplied with the Alarm Panel.

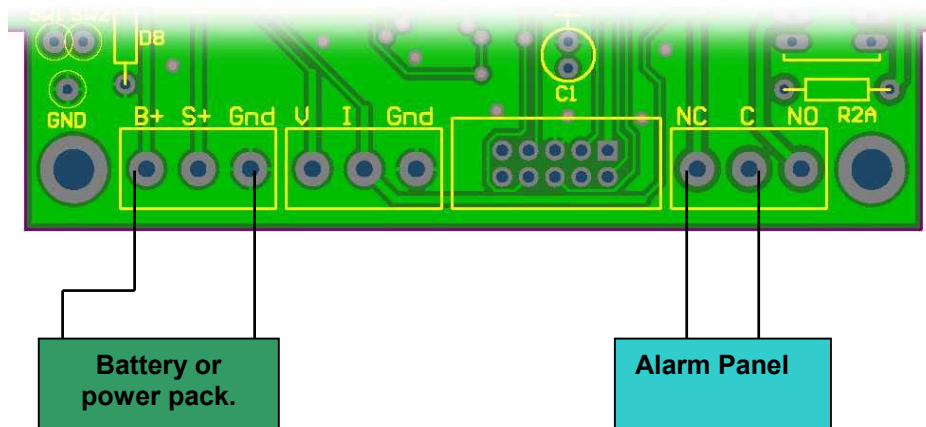

Figure 3 - Alarm Panel Operation

## Solar Panel Operation

The PTE700 series monitors now have built in circuitry to charge a 12V lead acid battery (either sealed or a wet cell) from a solar panel. Only a 12V solar panel should be used, and its output power must not exceed 2W.

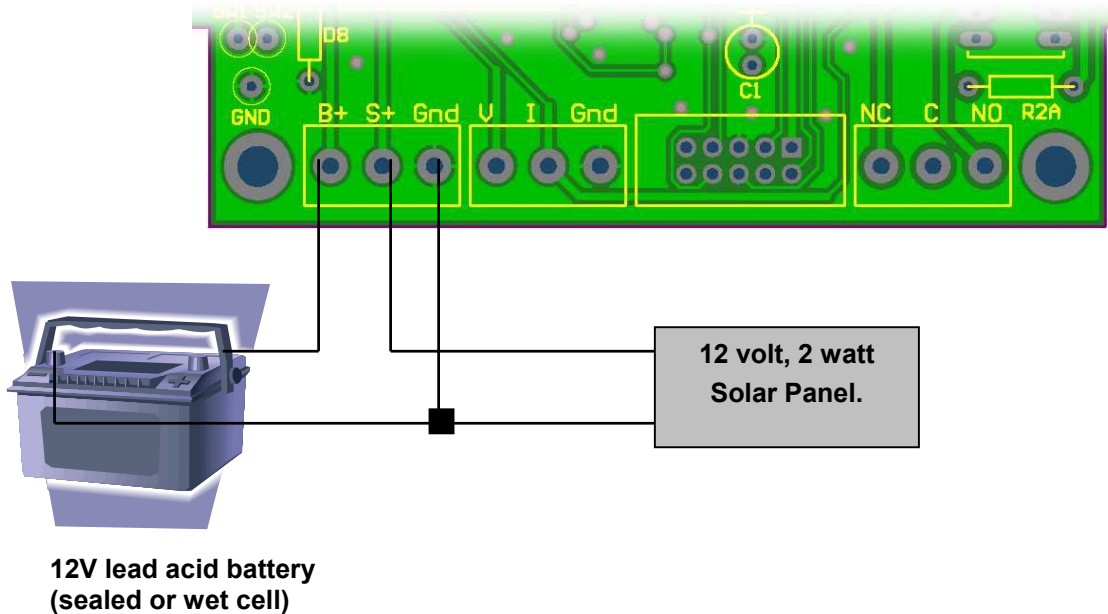

Figure 4 – Solar Panel Operation

## Low Fence Voltage Set Point Calibration – Automatic set point

- Turn the “Volts” trimmer fully anticlockwise
- Switch on the electric fence and ensure that it is operating in the expected range.
- Switch on the Electric Fence Monitor by supplying it with twelve volts. If the Electric Fence Monitor was already switched on, it needs to be reset by switching off (disconnecting the twelve volts supply) and switching back on.
- The Electric Fence Monitor has now automatically set the Low Fence Voltage Alarm Set Point and is now monitoring the Electric Fence. You can test its operation by deliberately placing a short on your electric fence – the Electric Fence Monitor will raise an alarm.
- It is recommended that Automatic set point NOT be used for security purposes. If the fence starts with a medium voltage (due to a fault, for example) the monitor may perceive that the fence is OK when it is not.

## Low Fence Voltage Set Point Calibration – Manual set point

- Turn the “Volts” trimmer fully anticlockwise and then **advance it clockwise slightly**. If you do not advance the trimmer, the Electric Fence Monitor will think that it is to automatically calibrate.
- Switch on the electric fence and ensure that it is operating in the expected range.

- Switch on the Electric Fence Monitor by supplying it with twelve volts.
- The Green Pulse LED should be flashing, indicating a working fence. The Low Fence Voltage Alarm Set Point is very low at present, because the “**Volts**” trimmer is turned almost completely anticlockwise. Gradually increase the set point by slowly turning the trimmer clockwise. The Low Fence Voltage Alarm Set Point is slowly increasing and will soon rise above your electric fence’s voltage. When this happens, the Green Pulse LED will stop flashing, the Red Low LED will flash and after the delay set on the delay trimmer, the Fail LED, alarm beeper and relay will activate.
- The Low Fence Voltage Set Point is now about the same as your electric fence’s voltage and needs to be lowered slightly. Do this by turning the “**Volts**” trimmer anticlockwise until the Green Pulse LED begins to flash again. If the alarm came on it will self clear in about 30 seconds.

### **Delay Calibration – automatic and manual low fence voltage alarm set point.**

- After setting the Volts trimmer (or using automatic setpoint) as above. The Green Pulse LED should be flashing.
- Switch off the electric fence OR place a short across the live to ground to remove the voltage at the monitor. Note the amount of time taken for the Electric Fence Monitor to raise an alarm. Turn the “**Delay**” trimmer anticlockwise to reduce the delay and clockwise to increase the delay.
- The shorter the delay is, the more likely the Electric Fence Monitor is to raise a false alarm, because every electric fence will have an occasional low voltage pulse.
- Switching the electric fence back on or removing the short will cancel the alarm after about 30 seconds; the Green Pulse LED should begin to flash again.

## 8.0 Electric Fence Monitor Outputs

### LED Visual Display

All Models

The Electric Fence Monitor status can be visually inspected via the three provided LEDs<sup>1</sup>.

The Pulse (Green) LED will pulse green for each input pulse which exceeds the setting of the Volts trimmer. If the input voltage is below the setting the Low (centre RED) LED will pulse on. If the voltage is low (or off) for a time as set by the delay trim the Alarm LED will light. Note that the PTE0702 has a fail safe output. In this case the Alarm LED is green. The PTE0702 will show a green Alarm LED when the fence voltage is good and it will go out when the voltage is low.

### Relay Output

All Models

The Electric Fence Monitor Relay has three terminals. These three terminals are: Common [C], Normally Closed [NC] and Normally Open [NO.] When the fence is operating correctly and when there is no power supply for the Electric Fence Monitor, the C and NC terminals are shorted, and the NO terminal is not connected to anything. When the fence voltage goes low and the Electric Fence Monitor raises an alarm, the relay toggles, connecting the C and NO terminals, and disconnecting the NC terminal. These contact are intended to be connected to external alarm panels inputs, sirens or strobes.

Terminal	Function
NC	Normally Closed
C	Common
NO	Normally Open

Table 3 – Relay Connections

#### NOTE:

- The relay contacts are rated at 30V, 1A (<500mA recommended). They **MUST NOT** be used to switch 240Vac.
- The Relay is fail safe on the PTE702 only. This means that in the alarmed condition, the C and NC terminals are shorted.

<sup>1</sup> The Remote Monitor will need to be opened for this feature to be used. When not using this feature the unit should remain closed to protect it from the elements.

## 0-5V Analog Output

PTE0700 Only
--------------

The 0-5V Analogue Output is from terminals V and GND. The minimum suggested load resistance on the 0-5V output is 1k. The 0-5V analogue output voltage linearly represents the fence voltage ranging from 0-10kV, ie:

$$\text{Fence Voltage} = (\text{Analogue Output Voltage}) \times 2000$$

Note: The monitor has software filtering which is intended to give the average output over the last 4 pulses.

## 4-20mA Analog Output

PTE0700 Only
--------------

The monitor current loop output (terminal I) is a current sink (or passive transmitter). Wire the output so that current flows from positive supply (5-12V) through the input of the 4-20mA receiver equipment and then to terminal I. The current range of 4-20mA will linearly represent a fence voltage range of 0-10kV, ie:

$$\text{Fence Voltage} = (0.625 \times (\text{Loop Current})) - 2.5$$

Take care to read the instructions for the receiving analog input device.

## RS232 Output

PTE0701, PTE0702 Or PTE0703
-----------------------------

The RS232 Output is available in two forms. The first is the default RS232 format for the PTE0701 and PTE0702. The second is used with the PTE0703 and is a more SCADA friendly output. Other formats may be available on request.

Pin	Function
I (Tx)	Transmit
Gnd	Ground
V (Rx)	Receive (used for negative biasing the transmit)

Table 4 – PTE0700 RS232 Connections

## PTE0701 and PTE0702

The output string is:

```
V 5500 CR LF
```

Where:

5500 is a representation of the fence voltage and CR is a carriage return and LF is a line feed.

## PTE0703

The receiving equipment should be programmed to expect a 6 character packet STX, voltage (4 ASCII), CR where STX is binary 2 and CR is a carriage return.

At turn on the PTE0703 also transmits some diagnostics information (see below). This can be ignored by the receiver as it is not prefaced by an STX. Please note that while the PTE703 transmits 4 significant digits the basic accuracy is only 8 bit (2 digit). In the print out below 6117 represents 6.1kV. When no pulse is seen for over 4 seconds 0000 is sent.

```
Ver 1.42 7/05/03
```

```
auto 0000
```

```
set 0116
```

```
del 0126
```

```
batt 0135
```

```
6117
```

```
6117
```

```
6117
```

```
6117
```

```
6117
```

```
6117
```

```
0000
```

```
0000
```

```
0000
```

```
0000
```



## Optional Display Board

The PTE0700 series monitors now have the provision for an optional LCD display PCB. The PAE036 LCD Expansion PCB connects via a 10 way ribbon cable to the expansion header on the PTE0700 PCB. It is secured to the PCB via 4 standoffs (provided). The display will show the low voltage setpoint and the actual fence voltage. It also displays a battery symbol when the supply voltage falls below a satisfactory level. Note that the LCD board must be removed to adjust the Low Voltage and Delay set point trimmers.



Figure 5 – PAE036 LCD Expansion PCB

## 9.0 Warranty

The PTE0700 Electric Fence Remote Monitor Series is covered by a 12-month warranty against defective parts or workmanship. If you have any problems, return the Monitor to Pakton Technologies Pty Ltd along with your proof of purchase, or contact the store of purchase or distributor.

### **For assistance**

If you have any operational problems, difficulties etc. call our FREE HELP LINE: 1800 249 642 (within Australia only and not from mobile phones)

Alternatively, phone fax or email your questions or comments to Pakton:

Phone (07) 3888 3793	International +61 7 3888 3793
Fax (07) 3888 4330	International +61 7 3888 4330

E-mail: [sales@pakton.com.au](mailto:sales@pakton.com.au)

Mailing address:

PO Box 408  
Narangba QLD 4504  
Australia

Street address:

16 Ferrier Road  
NARANGBA Qld 4504  
Australia

More help is available at the WEB site: [www.pakton.com.au](http://www.pakton.com.au)