

LOADRITE™

X SERIES

X-WEIGH 2350™

User Manual

FOR LOADRITE™ X-WEIGH 2350
EXCAVATOR WEIGHING SYSTEMS

LOADRITE™



LOADRITE™ X-Weigh 2350 User Manual

Software Number: 60345 Version Number: 3.5

Document Number: MAN-80898-04

Issued Date: February 2013

E: info@loadritescales.com

W: www.loadritescales.com

A solution from



www.actronictechnologies.com

© 2013 Actronic Ltd. All rights reserved. Actronic Technologies, C-Weigh, Express, Loadrite, Pro, Road Boss and X-Weigh are trademarks and/or registered trademarks of Actronic Ltd. All other trademarks and registrations are the property of their respective owners.





The software contains proprietary information of Actronic Ltd; it is provided under a license agreement containing restrictions on use and disclosure and is also protected by copyright law. Reverse engineering of the software is prohibited.

This document is copyrighted with all rights reserved. Under copyright laws, this document may not be copied in whole or in part, reproduced in any other media, stored in a retrieval system, or transmitted in any form or by any means, electronic, mechanical, photocopying, recording or otherwise, without the express written permission of Actronic Ltd. Permitted copies must carry the same proprietary and copyright notices as were affixed to the original. Under the law, copying includes translation into another language.

Published in New Zealand.

IMPORTANT SAFETY INFORMATION

PLEASE READ CAREFULLY BEFORE USING THE LOADRITE™ WEIGHING SYSTEM

	<p>This is the safety alert symbol. It is used to alert you to potential personal injury hazards. Obey all safety messages that follow this symbol to avoid possible injury or death.</p>
	<p>WARNING indicates a potentially hazardous situation which, if not avoided, could result in death or serious injury.</p>
	<p>CAUTION indicates a potentially hazardous situation which, if not avoided, may result in minor or moderate injury.</p>
	<p>CAUTION used without the safety alert symbol indicates a potentially hazardous situation which, if not avoided, may result in property damage.</p>



It is your sole responsibility to place, secure and use the LOADRITE™ Weighing System in a manner that will not cause accidents, personal injury or property damage. Always observe safe operating practices.

Do not install the LOADRITE™ Weighing System in a way that may interfere with the safe operation of the vehicle, or deployment of safety equipment.

Before you use the LOADRITE™ Weighing System for the first time, familiarize yourself with the system and its operation.



Do not handle the LOADRITE™ Weighing System if it is hot. Let the product cool, out of direct sunlight.

Ensure that the LOADRITE™ Weighing System is connected to a power source with the correct fitting and voltage requirements.

Do not attempt to service the LOADRITE™ Weighing System as this could result in personal injury.



Removing LOADRITE™ Weighing System equipment or adding accessories could affect the accuracy of weighing data and your warranty.

Do not install cables over horizontal surfaces where they may be stood on or hit by falling objects.

Failure to adhere to these warnings and cautions may lead to death, serious injury or property damage. Actronic Ltd disclaims all liability for installation or use of the LOADRITE™ Weighing System that causes or contributes to death, injury or property damage, or that violates any law.

TABLE OF CONTENTS

1.	WELCOME.....	1-6
2.	INTRODUCTION.....	2-7
2.1.	LOADRITE™ equipped excavator	2-8
2.2.	Indicator features	2-9
2.3.	The Total screen.....	2-11
2.4.	Accurate weighing.....	2-12
3.	THE DAY-TO-DAY WEIGHING PROCESS	3-13
3.1.	How do I turn on the Indicator?	3-13
3.2.	How do I log in?.....	3-13
3.3.	How do I set the Trigger Level?	3-14
3.4.	How do I perform a warm up?.....	3-15
3.5.	How do I zero the empty bucket?	3-15
3.6.	How do I select a product to weigh?.....	3-15
3.7.	How do I weigh and add a bucket load?	3-16
3.8.	How do I finish the load?	3-19
3.9.	How do I put the Indicator into Standby mode?	3-19
4.	THE SHORT AND LONG TOTALS	4-20
4.1.	Clear the short total	4-20
4.2.	View and clear the long total.....	4-20
5.	PRODUCT MANAGEMENT	5-22
5.1.	Customizable Data fields	5-22
5.2.	Auto-target value look-up	5-26
6.	OPERATION MODES.....	6-27
6.1.	Target mode	6-28
6.2.	Split mode	6-30
7.	PRINTING	7-31
7.1.	Automatic printing.....	7-31
7.2.	Printing on demand	7-31
8.	MAIN MENU.....	8-35
8.1.	Setup... ..	8-36
8.2.	Language.....	8-36
8.3.	Clock	8-36
8.4.	Contrast	8-37
8.5.	Brightness	8-37
8.6.	Scale #.....	8-37
8.7.	Long Total.....	8-37
8.8.	Clear all.....	8-37
8.9.	Auto-Add	8-38

8.10.	Edit Password.....	8-38
8.11.	Module.....	8-38
8.12.	Data Edit.....	8-38
8.13.	Data List	8-39
8.14.	Self test	8-41
8.15.	Uplink.....	8-41
9.	APPENDIX A: SYSTEM SPECIFICATIONS	9-42
9.1.	Suitable applications	9-42
9.2.	Weighing accuracy	9-42
9.3.	Minimal weighing delay	9-42
9.4.	Power requirements	9-42
9.5.	Physical specifications.....	9-42
9.6.	Environmental Specifications	9-42
9.7.	Signal inputs and outputs	9-42
9.8.	Clock	9-43
9.9.	Available accessories	9-43
9.10.	Output/Input connections.....	9-43
10.	APPENDIX B: SPAN CALIBRATION ADJUSTMENT	10-45
10.1.	Checking the adjustment	10-46
11.	APPENDIX C: ERROR MESSAGES.....	11-47
11.1.	Bucket Limits Error	11-47
11.2.	Bucket stick limits error.....	11-47
11.3.	Check Bucket	11-47
11.4.	Check Tilt 1.....	11-47
11.5.	Check Tilt 2.....	11-47
11.6.	Check Trigger 1	11-47
11.7.	Check Trigger 2	11-47
11.8.	Check power.....	11-47
11.9.	Check transducer.....	11-47
11.10.	Check trigger	11-47
11.11.	Check zero.....	11-48
11.12.	Lift not smooth	11-48
11.13.	Lift over range	11-48
11.14.	Lift speed too high	11-48
11.15.	Lift under range.....	11-48
11.16.	Module data lost	11-48
11.17.	Module error.....	11-48
11.18.	Module full.....	11-48
11.19.	Overload	11-48
11.20.	Over target.....	11-48
11.21.	Poor lift	11-49
11.22.	Printer disabled.....	11-49
11.23.	Printer error	11-49

11.24.	Return over range	11-49
11.25.	Return under range	11-49
11.26.	Slew RPM too high	11-49
11.27.	Stick limits error	11-49
11.28.	Too heavy, zero aborted	11-49
11.29.	Unstable load	11-49
11.30.	Warm-up lift	11-49
12.	APPENDIX D: LEGAL INFORMATION.....	12-50
13.	APPENDIX E: GLOSSARY	13-52

1. WELCOME

Thank-you for purchasing this LOADRITE™ Weighing System. Please read this manual carefully before using the Indicator for the first time. Keep this manual in a safe place and use as your first point of reference.

Formatting

The following formatting in this manual identifies specific types of information:

Convention	Type of Information
Bold	<ul style="list-style-type: none"> ▶ Indicates a button on the Indicator, or ▶ Indicates an area displayed on-screen, including buttons, headings, field names and options.
<i>Italics</i>	<ul style="list-style-type: none"> ▶ Indicates the name of a screen or window, or ▶ Indicates an operation mode that the Indicator can be set to.
Monospace	The exact error message displayed on-screen.

Action Terms

The following terms are used throughout this manual to describe actions:

Term	Description
Press	Push and release a button quickly.
Press and hold	Push and hold a button for 2-3 seconds.
Select	<ul style="list-style-type: none"> ▶ Use the arrow buttons to "highlight" an item in a menu or list, or ▶ When searching for a product or Data Field value, use the keypad to enter the name of the product. The product which matches the name entered will be "highlighted".

2. INTRODUCTION

The LOADRITE™ Weighing System measures the weight of loads lifted by hydraulic excavators. The main parts of the LOADRITE™ Weighing System are:

- ▶ the Indicator installed in the cab of the excavator, and
- ▶ the connected sensors installed on the lifting arms, chassis and hydraulics.

As a load is lifted, the rotary triggers, angle sensors and hydraulic pressure transducers send information to the LOADRITE™ Indicator. This information is converted into a digital weight reading that is displayed on the LOADRITE™ Indicator.

The LOADRITE™ Weighing System can add each lifted load to running totals so that Trucks are loaded accurately and daily productivity levels can be tracked.

The LOADRITE™ Indicator is the main user interface with the LOADRITE™ Weighing System. It has an internal memory that stores settings and production data even when it is turned off.





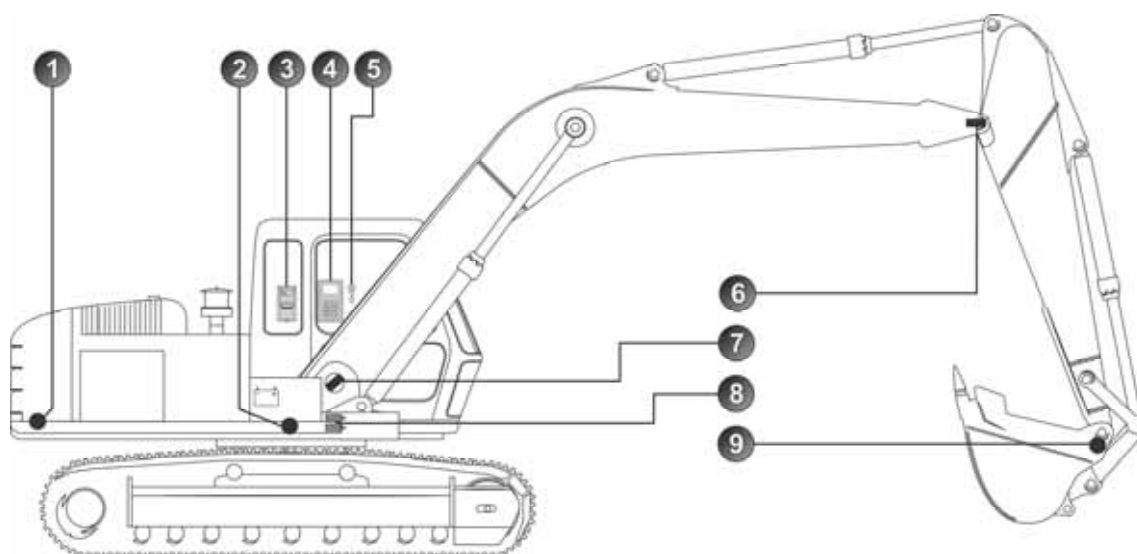







2.1. LOADRITE™ EQUIPPED EXCAVATOR



	Component
1	Tilt Sensor 2
2	Tilt Sensor 1
3	Printer (optional)
4	LOADRITE™ Indicator
5	Remote Add Button (optional)
6	Stick (dipper arm) Position Sensor
7	Boom Position Sensor
8	Pressure Transducers
9	Bucket Sensor (optional)

2.2. INDICATOR FEATURES

Icon	Name	Description
	Trigger Light	Illuminates when a load is lifted through the weighing zone. When this light is on, the load may be added.
	1 Product	<ul style="list-style-type: none"> ▶ Used to enter the number 1. ▶ Displays the <i>Product</i> screen. ▶ Scrolls up the list of products on the <i>Product</i> screen.
	2 Data 1	<ul style="list-style-type: none"> ▶ Used to enter the number 2. ▶ Displays the <i>Data 1</i> screen. ▶ Scrolls up the list on the <i>Data 1</i> screen. <p>Note: The name of the <i>Data 1</i> screen will depend on configuration settings.</p>
	3 Data 2	<ul style="list-style-type: none"> ▶ Used to enter the number 3. ▶ Displays the <i>Data 2</i> screen. ▶ Scrolls up the list on the <i>Data 2</i> screen. <p>Note: The name of the <i>Data 2</i> screen will depend on configuration settings.</p>
	4 Data 3	<ul style="list-style-type: none"> ▶ Used to enter the number 4. ▶ Displays the <i>Data 3</i> screen. ▶ Scrolls up the list on the <i>Data 3</i> screen. <p>Note: The name of the <i>Data 3</i> screen will depend on configuration settings.</p>
	5 Target	<ul style="list-style-type: none"> ▶ Used to enter the number 5. ▶ Selects the weighing mode, for example, <i>Target mode</i>.
	6 Product	<ul style="list-style-type: none"> ▶ Used to enter the number 6. ▶ Displays the <i>Product</i> screen. ▶ Scrolls down the list of products on the <i>Product</i> screen.
	7 Data 1	<ul style="list-style-type: none"> ▶ Used to enter the number 7. ▶ Displays the <i>Data 1</i> screen. ▶ Scrolls up the list on the <i>Data 1</i> screen. <p>Note: The name of the <i>Data 1</i> screen will depend on configuration settings.</p>
	8 Data 2	<ul style="list-style-type: none"> ▶ Used to enter the number 8. ▶ Displays the <i>Data 2</i> screen. ▶ Scrolls up the list on the <i>Data 2</i> screen. <p>Note: The name of the <i>Data 2</i> screen will depend on configuration settings.</p>
	9 Data 3	<ul style="list-style-type: none"> ▶ Used to enter the number 9. ▶ Displays the <i>Data 3</i> screen. ▶ Scrolls up the list on the <i>Data 3</i> screen. <p>Note: The name of the <i>Data 3</i> screen will depend on configuration settings.</p>

Icon	Name	Description
	0 Target	<ul style="list-style-type: none"> ▶ Used to enter the number 0. ▶ Selects the weighing mode, for example, <i>Target mode</i>.
	Printer Menu Down	<ul style="list-style-type: none"> ▶ Displays the <i>Print Menu</i>. ▶ Moves down a list of options.
	Main Menu Up	<ul style="list-style-type: none"> ▶ Displays the <i>Main Menu</i>. ▶ Moves up a list of options.
	Recall Subtract Back Cancel	<ul style="list-style-type: none"> ▶ Recalls the last load. ▶ Subtracts the current load from the total. ▶ Moves back one menu screen. ▶ Cancels changes.
	Weighing Zone Decimal Point	<ul style="list-style-type: none"> ▶ Adjusts the Weighing Zone. ▶ Used to enter a decimal point.
	Split Mode	Activates <i>Split</i> mode weighing.
	Back Cancel Standby Mode	<ul style="list-style-type: none"> ▶ Moves back one menu screen. ▶ Cancels changes. ▶ Puts the Indicator into <i>Standby</i> mode.
	Enter	<ul style="list-style-type: none"> ▶ Selects an item. ▶ Accepts changes.
	Add	<ul style="list-style-type: none"> ▶ Adds the current bucket load to the total. ▶ Turn <i>Auto-Add</i> on or off. ▶ Move the cursor left when entering text.
	Clear	Clears the short total for the current product.
	Zero	<ul style="list-style-type: none"> ▶ Zeroes the empty bucket. ▶ Move the cursor right when entering text.

2.3. THE TOTAL SCREEN

The *Total* screen is the first screen that you will see when you turn on the Indicator. It displays the currently selected Product, short total, number of bucket loads and other information.

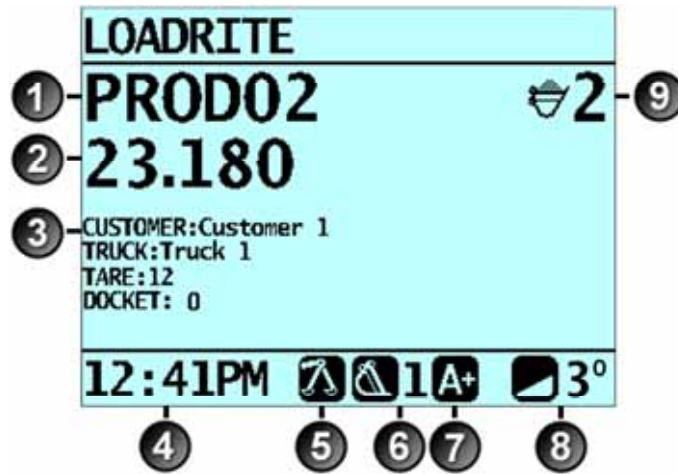

	Component	Description
1	Product	The product being loaded.
2	Short Total	The current short total of product that has been loaded.
3	Data Fields	<ul style="list-style-type: none"> ▶ The current values of the three Customizable Data Fields . ▶ The Docket Number Data Field, if configured.
4	Clock	The current time.
5	Stick Error / Bucket Error	<ul style="list-style-type: none"> ▶ The stick angle is outside of the specified limits for weighing, or ▶ The bucket is outside of the specified limits for weighing, or ▶ Both of the above.
6	Weighing Implement	The weighing implement being used by the excavator.
7	Auto-Add	Indicates that the <i>Auto-add</i> functionality is On .
8	Unit of Weight / Pitch	<ul style="list-style-type: none"> ▶ The unit of weight being used. The Short total is displayed in this unit of weight. ▶ The angel of pitch (front/back tilt) of the excavator.
9	Bucketloads	The number of bucketloads that have been added to the short total.

2.4. ACCURATE WEIGHING

For maximum accuracy, ensure that:

- ▶ Check Zero is performed regularly.
- ▶ Load lifting motion is steady and smooth, with no acceleration or bounce.
- ▶ The bucket remains level.
- ▶ Material does not spill from the bucket while weighing, or before the bucket is emptied on to the truck.

2.4.1. Obtaining the Best Weighing Results

Lifting Speed

The hydraulic pressure required to lift a load varies with the speed of the lift. The Indicator corrects for most variations, but accuracy is increased if you are consistent with the range of lifting speed used.

Trigger Level

The Indicator starts to calculate the weight of each load as the bucket moves through the Trigger Level. It is therefore very important to ensure that the movement is as stable as possible before passing through the Trigger Level.

Set the Trigger Level to be after the bucket is clear of the digging area to avoid shudder associated with breaking free of the material being loaded.

- ▶ To set the Trigger Level, see "How do I set the Trigger Level?" on page 3-15.

Center of Gravity

The hydraulic pressure in the lifting cylinders depends on where the center of gravity is for the load. Therefore it is important that the bucket is kept level throughout each lift.

Slewing

Slewing the excavator introduces additional factors that need to be compensated for. To ensure that the most accurate result is achieved, do not slew until the Indicator has calculated the weight of the load.

3. THE DAY-TO-DAY WEIGHING PROCESS

The following is the basic process for day-to-day weighing with the LOADRITE™ Weighing System:

- 1) Turn on the Indicator and log in (if required).
- 2) Set the Trigger Level.
- 3) Perform a warm-up.
- 4) Zero the empty bucket.
- 5) Select a product to weigh.
- 6) Weigh and add each bucketload.
- 7) When you have finished loading the truck, clear the short total.
- 8) When you have finished using the LOADRITE™ Weighing System, put the Indicator into *Standby* mode.

3.1. HOW DO I TURN ON THE INDICATOR?

The LOADRITE™ Indicator will turn on automatically when you start the excavator.



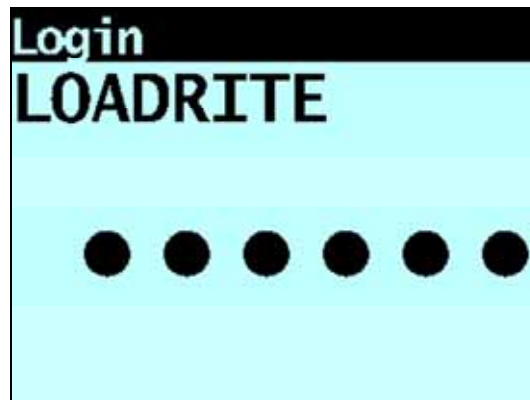

3.2. HOW DO I LOG IN?

The *Login* functionality is only available if selected at installation.

The *Login* screen will display when the indicator turns on, or comes out of *Standby* mode.



If you see the *Login* screen, complete the following to log in to the Indicator:

- 1) Press  or  to scroll up or down through the login names.
- 2) When your login name is displayed, press .
- 3) Use the keypad to enter your PIN number, then press .

3.3. HOW DO I SET THE TRIGGER LEVEL?

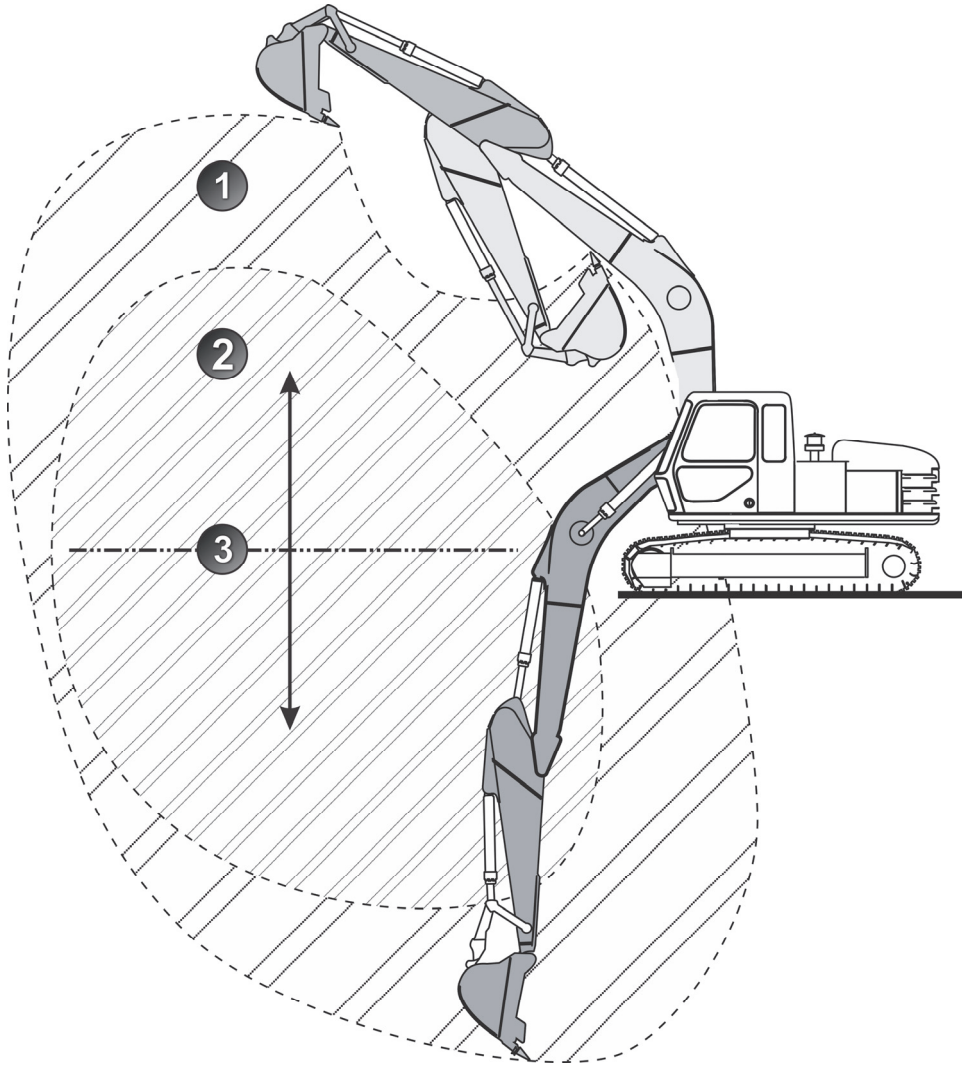

The range of motion that the excavator has when loading is called the Weighing Zone and is dependent on the location of the excavator. For example, the excavator could be operating on top of a stockpile or at a roadside.

To ensure weighing accuracy, the LOADRITE™ Weighing System needs to know the correct Trigger Level for the Weighing Zone. The Trigger Level is approximately 3 feet (1 meter) above the stockpile or material being dug out and should be set every time the digging location changes.



	Description
1	Excavator Arm Reach
2	Weighing Zone
3	Trigger Level

To set the Trigger Level, complete the following:

- 1) Move the bucket to approximately 3 feet (1 meter) above the stockpile .
- 2) Press .
The message **Set Trigger Lvl?** will display.
- 3) Press  to confirm the Trigger Level, or  to cancel.

3.4. HOW DO I PERFORM A WARM UP?

For best weighing accuracy, the hydraulic fluid in the lift cylinders should be at normal operating temperature. This is achieved by raising and lowering the empty bucket.

Warm Up Lift 3

The above message will display if the Indicator has been turned off for more than one hour. If you see the above message, you need to raise and then lower the empty bucket through the weighing zone three times:

- 1) Raise the bucket through the weighing zone.
- 2) Lower the bucket through the weighing zone.
- 3) Repeat two more times until the message disappears.
When the warm up has completed, the *Total* screen will display.

3.5. HOW DO I ZERO THE EMPTY BUCKET?

The *Check Zero* functionality is only available if selected at installation.

It is necessary to periodically "zero" the LOADRITE™ Weighing System because small errors can occur due to a build-up of material in the bucket.



Check Zero

If you see the above message, you need to zero the empty bucket. The message will display:





- ▶ Every 15 minutes for the first hour, and
- ▶ Every 30 minutes thereafter (the default period is 30 minutes, but it may be set between 15-180 minutes).

Complete the following to zero the bucket:

IMPORTANT: When weighing a load, the excavator must be level and the bucket must be kept level during the lift.

- 1) Ensure that the excavator is level and the bucket is empty.
- 2) Raise the empty bucket.
- 3) Press .
The **Zero Updated** message will display, before the *Total* screen is displayed.

3.6. HOW DO I SELECT A PRODUCT TO WEIGH?

- 1) Ensure the *Total* screen is displayed.
- 2) Press  or .
The *Product* screen will display.
- 3) Press  or  to scroll up or down the list of products until the correct product is selected.
- 4) Press .
The name of the product will be displayed for one second, then the *Total* screen will display.

3.7. HOW DO I WEIGH AND ADD A BUCKET LOAD?

When the *Total* screen is displayed, bucketloads can be weighed.

IMPORTANT: When weighing a load, the excavator must be stable and the bucket must be kept level. Minimize slewing the excavator until the weight is displayed.

- 1) Raise the bucket load smoothly through the Weighing Zone using a constant boom motion. The **Weighing** message will display.
- 2) The Indicator will beep,  (Trigger light) will illuminate and the *Live Weight* screen will display the weight of the current load, the short total and the potential new weight.



- 3) Press  to add the load. A message will display the number of buckets added to the current load, for example **Bucket Add #1**.

Note: If  is not pressed within 8 (eight) seconds of the load being lifted through the Weighing Zone, the Indicator will beep and the **Time Out** message will display. The weight will then be discarded and the *Total* screen will display. The number of seconds before the Indicator times out may differ, depending on how it was set during installation.

When the load has been added, the *Total* screen will display with the new short total and the number of bucket loads.

3.7.1. Auto-Add





The *Auto-Add* functionality is only available if selected at installation.



The LOADRITE™ Weighing System can be set to automatically add a bucket load when lifted through the weighing zone for a specified number of seconds. This means that you don't need to press  after lifting each load.

Depending on installation setup:

- ▶ Bucket loads may not be added if under a specified amount
- ▶ *Auto-Add* may be turned on or off via the *Setup Menu* or by pressing  (Auto-Add toggle).

3.7.1.1. Turn Auto-Add On or Off

- 1) Press  twice.
The *Main Menu* will display.
- 2) Press  or  to scroll up or down until **Auto-Add** is selected, then press .
- 3) Complete the following:

If you want to...	Then...
turn <i>Auto-Add</i> on	use the arrow buttons to select On , then press  .
turn <i>Auto-Add</i> off	use the arrow buttons to select Off , then press  .



- 4) Press  to return to the *Total* screen.

3.7.1.2. Auto-Add toggle



The *Auto-Add toggle* functionality may or may not be available depending the configuration of your Indicator.

You can toggle between using Auto-add and using the normal add process from the *Total* screen.

Turn Auto-Add on

- 1) From the *Total* screen, press and hold .
- The **Auto-Add On?** message will display.
- 2) Press .
- The message will change to **Auto-Add On** and the *Total* screen will display.

Turn Auto-Add off

- 1) From the *Total* screen, press and hold .
- The **Auto-Add Off?** message will display.
- 2) Press .
- The message will change to **Auto-Add Off** and the *Total* screen will display.

3.7.2. Remote Add button



The LOADRITE™ Weighing System has an optional **Remote Add** button which is normally mounted on or near the boom lever. If the **Remote Add** button is installed in your excavator you can use it interchangeably with the  button on the Indicator.



3.7.3. Subtract a bucket load

This function can be useful when only part of a final load of loose material is required. Weigh and add a full load, then tip the amount required into the truck. Then re-weigh and subtract the amount remaining by completing the following:

IMPORTANT: When weighing a load, the excavator must be stable and the bucket must be kept level. Minimize slewing the excavator until the weight is displayed.

- 1) Raise the load smoothly past the through the weighing zone.
- 2) The Indicator will beep,  (Trigger light) will illuminate and the weight of the current load, the short total and the potential new weight will display.
- 3) Press .
The **Bucket Subtract** message will display. The amount will be subtracted from the short total. The *Total* screen will display.

3.7.4. Recall a bucketload



The *Recall* function is equivalent to lifting the same load again and can be used to correct mistakes. The last load can be recalled if it has been added or subtracted.

To recall a previously lifted weight, complete the following:

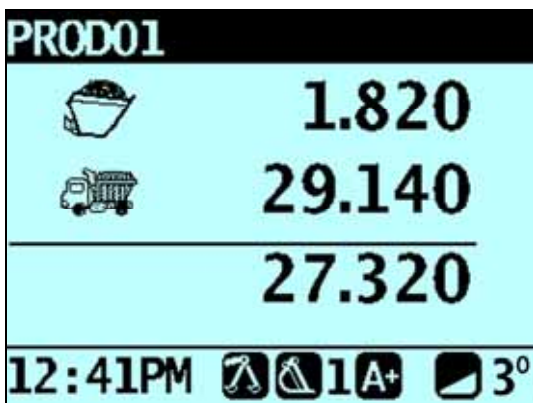
- 1) Press .
The last weight lifted will be displayed.



- 2) Complete the following:

If...	Then...
the last action was an "add"	press  . The bucketload is subtracted from the short total and long total.
the last action was a "subtract"	press  . The bucketload is added to the short total and long total.

3.8. HOW DO I FINISH THE LOAD?

When you have finished adding loads to the truck, you must clear the short total.

To clear the short total, complete the following:

- ▶ Press and hold .
The short total will display briefly, followed by the **Total Cleared** message, then the *Total* screen.

For more information on the short total, see "The short and long totals" on page 4-20.

3.9. HOW DO I PUT THE INDICATOR INTO STANDBY MODE?

If you are not going to use the LOADRITE™ Weighing System for a while, you can put the Indicator into *Standby* mode by completing the following:

- ▶ Press .
The Indicator will enter *Standby* mode.

How do I exit *Standby* mode?

- ▶ Press any button to exit *Standby* mode.
Either the *Login* screen or *Total* screen will display.

4. THE SHORT AND LONG TOTALS

The LOADRITE™ Weighing System keeps a running total of the load weights. For each product, two independent totals are stored - the short total and the long total.

Term	Definition
Short Total	The running total amount of product weighed and loaded onto a excavator or carriage. The Short Total amount is displayed on the <i>Total</i> screen and will continue to accumulate until it is cleared by pressing  .
Long Total	The total amount of product loaded over a long period, such as a work shift or day.

4.1. CLEAR THE SHORT TOTAL





The short total keeps accumulating until it is cleared. Clear the short total after a load has been completed, for example, after each truck or carriage load.

- ▶ Press .
The short total will display briefly, followed by the **Total Cleared** message, then the *Total* screen.

Note: If the LOADRITE™ Weighing System has a printer connected, then depending on your installation settings, (i) the totals may be printed before being cleared, or (ii) you may be prompted to print the totals after the **Total Cleared** message is displayed.

4.2. VIEW AND CLEAR THE LONG TOTAL



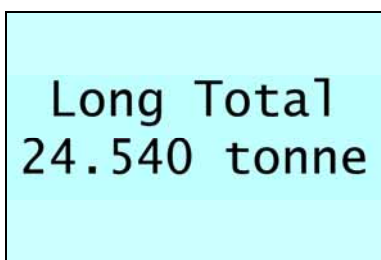

You can view the long total for the current product at any time.



- 1) Press  twice.
The *Main Menu* will display.
- 2) Press  or  to scroll up or down until **Long Total** is selected.
- 3) Press .
The long total will display.



After a few seconds, the Indicator will display the *Total* screen.







Clear the long total for the current products

- 1) Press  twice.
The *Main Menu* will display.
- 2) Press  or  to scroll up or down until **Long Total** is selected.
- 3) Press .
The long total for the current product is displayed along with the number of buckets added.

- 4) Press .
The **Long Total Clear?** message will display.
- 5) Press  again to clear the long total.
The **Long Total Cleared** message will display. If the LOADRITE™ Weighing System has a printer connected, the total will be printed.
 - ▶ Press  to cancel the clearing of the long total.
The **Clear Aborted** message will display.

Note: If no button is pressed, the clear command will be automatically canceled.

Clear the long total for all products

- 1) Press  twice.
The *Main Menu* will display.
- 2) Press  or  to scroll up or down until **Clear All** is selected.
- 3) Press .
The **All Totals Clear?** message will display.
- 4) Press  again to clear the long total.
The All Totals Cleared message will display. If the LOADRITE™ Weighing System has a printer connected, the total will be printed.
 - ▶ Press  to cancel the clearing of the long total.
The **Clear Aborted** message will display.

Note: If no button is pressed, the clear command will be automatically canceled.

5. PRODUCT MANAGEMENT

The LOADRITE™ Weighing System can be used to track multiple products (materials). Each product is associated with a product number, product name, Short Total, Long Total and bucket counter.

5.1. CUSTOMIZABLE DATA FIELDS

The *Customizable Data Fields* functionality is only available if selected at installation. For information on configuring data fields, refer to the *LOADRITE™ Toolbox User Manual*.

Your Indicator has three customizable data fields that are used to record information against each weight to help track and monitor weighing data.

For example, data fields may be configured to record a customer, truck type or truck ID, against the weight data.



The data can then be transferred via a modem, stored in a LOADRITE™ Data Module and/or printed along with the weight data.

- ▶ For the Docket Number Data Field, see "Docket Numbers" on page 5-25.



5.1.1. Select a data field

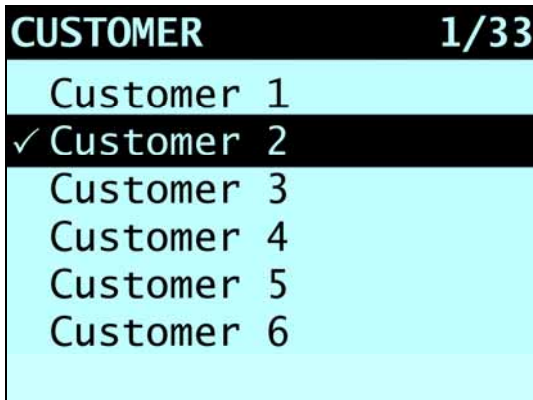

Data field values can be selected before starting a new load. The following example assumes that **Data 1** has been configured to hold customer names and shows how to select a customer name to record against the weighing data.

- 1) Press  or . The *Customer* screen will display.



- 2) Press  or  to scroll up or down the list of customers until the correct customer is selected.
- 3) Press . The customer will be recorded against all loads until a different customer is selected. The name of the customer will display under the **Short Total** on the *Total* screen.











5.1.2. How do I use the Indicator keypad to enter text?



You can enter numbers, letters or symbols on any screen that has a flashing cursor, for example the *Data Entry* and *Edit?* screens.



The Indicator has a keypad of buttons, with each used to select and enter a range of characters. When a button is pressed, the first character will appear on screen. If you press the button again within one second, the next character will display. If you continue to press the button, each character in the range will display in turn until the first character is displayed again.

One second after a button is pressed, the character will be entered and the cursor will move to the next space. You can then enter another character.

Characters







Button	Characters	Button	Characters
	[SPACE] 1 . , ? &		6 M N O m n o
	2 A B C a b c		7 P Q R S p q r s
	3 D E F d e f		8 T U V t u v
	4 G H I g h i		9 W X Y Z w x y z
	5 J K L j k l		[SPACE] 0 # : / + - "

When entering the first character of a value, the first time  is pressed, the number **2** will display; the second time  is pressed, **A** will display; the third time  is pressed, **B** will display, etc.

When entering other characters in the value, lower-case letters will display first, so the first time  is pressed, the letter **a** will display; the second time  is pressed, **b** will display; the third time  is pressed, **c** will display, etc.

Example

To enter the word **Pumice** using the keypad, you would complete the following:





- 1) To enter **P**, press  twice.
- 2) To enter **u**, press  twice.
- 3) To enter **m**, press .
- 4) To enter **i**, press  three times.
- 5) To enter **c**, press  three times.
- 6) To enter **e**, press  twice.

5.1.3. Adding a data field value

If the required data field value is not available to select, you can add the value using the keypad.

Important: Data field values can only be entered using specific *Western Latin* characters, such as in English.



The following example assumes that **Data 1** has been configured to hold customer names and shows how to add a new customer name:

- 1) Press  or .
The *Customer* screen will display.
- 2) Press .
The *Data Entry* screen will display.
- 3) Use the keypad to enter the name of the value, then press .
The new customer value will be assigned to the next load.

5.1.4. Editing a data field value



You can edit a data field value if required by using the *Data List* function.





Important: Data field values can only be entered using specific *Western Latin* characters, such as in English.

- 1) Press  twice.
The *Main Menu* will display.
- 2) Select **Data List**, then press .
The *Edit?* Screen will display.



- 3) Complete the following:







If ...	Then ...
you would like to edit a data value from the data field that is displayed	press  .
you would like to select a different data field	press  until the required data field is displayed, then press  .

- 4) Press  or  to scroll up or down the list of data values until the required data value is displayed, then press .
- 5) Use the keypad to edit the data value, then press .

Tip: Press  to clear the current value name.

- 6) Press .

7) Complete the following:

If ...	Then ...
you would like to edit another data value	<ul style="list-style-type: none"> ▶ press . ▶ Press  until the required data field is displayed, then press . ▶ Go back to step 4.
you would like to select a different data field	<ul style="list-style-type: none"> ▶ Press . ▶ press  until the required data field is displayed, then press . ▶ Go back to step 5.
you have finished editing data values	Press  twice to return to the <i>Main Menu</i> .

5.1.5. Docket Numbers

A fourth Data Field is available to record a docket number against each weight. The docket number is not editable, but will automatically increment by 1 for each load.



5.2. AUTO-TARGET VALUE LOOK-UP

The LOADRITE™ Weighing System can be configured so that target weights are stored for each truck. The target weights are configured during the setup of the LOADRITE™ Weighing System.





Below is an example of a truck and target list. **Data 2** has been configured to store truck plate numbers and **Data 3** to store the corresponding target values.

Data 2: Truck	Data 3: Target
AGT477	5000
AUQ887	4000
BQ1001	6000
BQ1002	5000

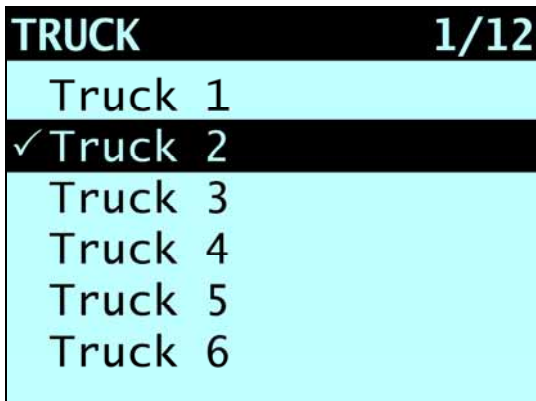
5.2.1. View and select target weights

- 1) Press  or .
The *Truck* screen will display.



- 2) Press  or  to scroll up or down the list of trucks until the correct truck is selected.
- 3) Press .
The target weights will display with the auto-target weight pre-selected.
- 4) Press  to confirm the target weight, or press  to clear the target weight and enter a new target weight.
The *Target* screen will display.

6. OPERATION MODES

The operation modes that are available depend on the modes selected at installation.

The LOADRITE™ Indicator can be operated in different modes:

Mode	Description
Total	This is the normal mode of operation. As loads are added, the weights are added to the totals. The short total is displayed.
Target	In this mode, a target weight is entered into the Indicator before loading. As loads are added, the remaining value to reach the target is displayed.
Split	The mode used when loading a multiple train wagons or a truck with multiple trailers where individual totals are required for each individual vehicle. Can be used within <i>Total</i> or <i>Target</i> modes.





6.1. TARGET MODE

Target mode is only available if selected at installation.

Target mode is typically used when loading a truck to its optimum payload. This feature provides an easy way to load up to a target weight for a product in a series of lifts. In Target mode, the Indicator displays the To load (or target) value, which is the remaining amount to reach the target.

Before loading, the operator enters a target weight. Each time a weight is added, the To load value is reduced by that weight.

6.1.1. How do I enter Target mode and input a new target?

- 1) Press  to clear the previous totals.
 - 2) Press  or .
 - 3) When the **Target?** message is displayed, use the keypad to enter the new target amount.
 - 4) Press .
- The **Target Updated** message will display briefly, then the Target screen will be displayed.

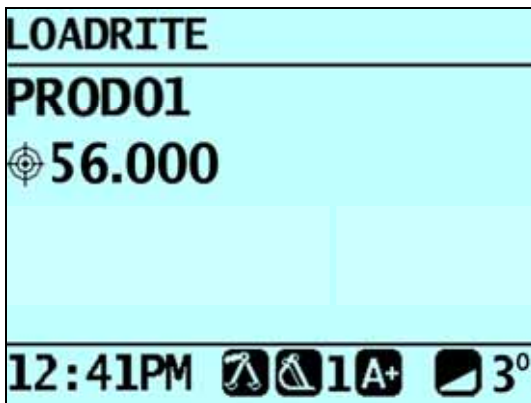

As you lift a weight, the target weight is displayed along with the current lifted weight and the potential weight if the lift is added.

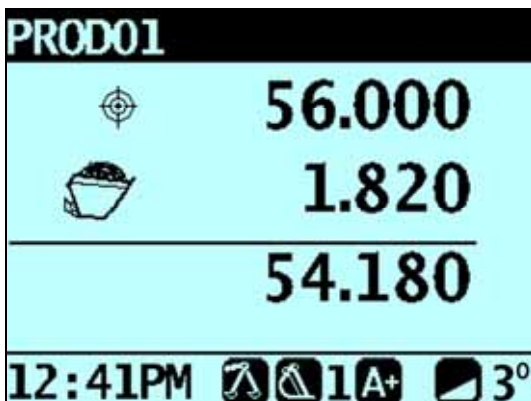

- 5) As the truck is loaded, the target amount will decrease. The aim is to get as close to 0 (zero) as possible. A positive To load value is under the target; a negative To load value is over the target.

6.1.2. How do I reset the target?

When the load is complete, the target must be reset. This is the equivalent of clearing the short total in *Total* mode.

- ▶ To reset the target, press .
The **Target Reset** message will display briefly and then the *Target* screen will display.

6.1.3. How do I return to Total mode?

To return to *Total* mode from *Target* mode, the target must be set to **0**.

- 1) Press  or .
- 2) When the **Target?** message is displayed, press , then press .
The *Total* screen will display.

6.2. SPLIT MODE

Split mode splits the total weight into multiple sub-totals, providing an easy way to load train wagons, or a truck and trailer. *Split* mode is also used to track load distribution over a single vehicle unit, to avoid overloading an axle. *Split* mode can be used in conjunction with *Total* or *Target* modes.

Example





A truck with a trailer requires loading. The truck can carry 10,000 tonnes and the trailer 15,000 tonnes, making a total of 25,000 tonnes.

6.2.1. Split mode within Total mode

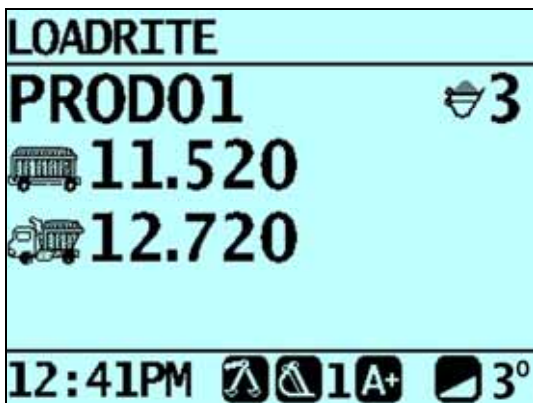

- 1) In *Total* mode, load the truck with the required amount or product.
- 2) When the required amount of product for the truck is reached, press . The subtotal will briefly display, then the Split screen will display. The grand total of the entire vehicle is shown along with the short total for the trailer.



- 3) Add the required amount of product to the trailer. The grand total will update along with the total number of buckets.
- 4) If you would like to split the load to another trailer, press , then go to step 3. Otherwise, continue to step 5.
- 5) When all trailers have been filled, press  to clear the totals.

6.2.2. Split mode within Target mode

- 1) In *Target* mode, enter the target weight for the truck.
- 2) Load the truck with the required amount of product.
- 3) When the required amount of product for the truck is reached, press . The *Split* screen will display with the target value for the trailer the same value that was entered for the truck in step 1.

- ▶ To change the target weight of the trailer, press  or .

When the **Target?** message is displayed, press  or  to enter a target weight for the trailer, then press .

- 4) Add the required amount of product to the trailer.
- 5) Press  to clear the totals. The *Total* screen will display.





7. PRINTING

The printing options that are available depend on options selected at installation.

Data on the LOADRITE™ Indicator can be printed immediately, or stored in internal storage for delayed printing. There is normally enough storage for up to one week, depending on usage.

7.1. AUTOMATIC PRINTING

Depending on your configuration, various weight data is printed either:

- ▶ when  is pressed at the end of a load, or
- ▶ when , ,  or  is pressed.

The information that is printed depends on settings selected at installation. For further information, contact your LOADRITE™ distributor.

7.2. PRINTING ON DEMAND

The LOADRITE™ Indicator has a range of options for printing data immediately. Printing options are selected from the *Print Menu*.

7.2.1. Print Docket

-  > *Print Menu* > *Last Docket*

The *Print Docket* function prints the previous load, which is made up of all data stored (for example, add, subtract) between the last two clear events. If the data is not stored, it will not be printed. For example, if the Indicator is not configured to log add events, weights added will not be printed. This function requires internal storage to be enabled. All configuration of this function is set during installation.

Note: This function will not work if *Clear* is not used as intended. For example, the operator is loading sand into a truck and half-way through, a second truck arrives. The operator switches product to rocks and starts loading the second truck (without clearing the sand total). When the docket is printed, the added weights of sand plus the added weights and total of rocks will be included.

7.2.2. Print Totals

-  > *Print Menu* > *Totals*

This function prints the total amount of each product loaded that day (since midnight).

7.2.3. Print Indicator Data

-  > *Print Menu* > *Loadout*

This printing option is only available if it has been enabled during installation and *Internal Storage* functionality is enabled.

This function prints out all print data stored in the LOADRITE™ Indicator memory since midnight (whether or not it has been turned off at any stage during that time).

Depending on the configuration, every add, clear, check zero, etc could be included in the printout.

7.2.4. Print Summary Report

➤  > *Print Menu > Summary*

This function prints out a summary report that is grouped and summarized by Data 1. For example, if **Data 1** is a customer field, then this function generates a customer total report using the data stored in the internal memory since midnight.



7.2.5. Print Special Report

➤  > *Print Menu > Special*

This function allows various reports to be printed from stored data. A series of options are available and the report is created from the options selected.

Format Options



Format	Description
Summary	Prints a summary of the selected data.
History	Prints all the selected data.
KPI	Prints the start time, end time, total weight and average weight per hour for each day of the selected period. Average weight per hour is based on cleared weights and the number of hours between the first and last weight of each day.

Press  or  to scroll up or down, then press .

The *Period Options* will be displayed.

Period Options



Format	Description
Today	Prints the report based on data recorded since midnight.
Yesterday	Prints the report based on data recorded for a 24 hour period prior to midnight.
This Week	Prints the report based on data recorded since midnight and the previous six days.
All	Prints the report based on all the data stored (this may have little relevance unless the start time is known).

Press  or  to scroll up or down, then press .

If **Today**, **Yesterday** or **This Week** was selected, the *Group Options* will display. If **All** was selected, the *Port Options* will display.

Group Options



Format	Description
Totals	The printout is grouped and summarized by product total.
Customer	The printout is grouped and summarized by Data Field 1.
Docket	The printout is grouped and summarized by Data Field 2.
Truck	The printout is grouped and summarized by Data Field 3.

Press  or  to scroll up or down, then press .

If **Totals** was selected, the *Port Options* will display. Otherwise the *Match Options* will display.

Match Options



Format	Description
Match All	All values are used on the printout.
Match One	Only one of the grouped values is reported on. For example, if the printout is grouped by Customer, a report can be generated on one Customer.

Press  or  to scroll up or down, then press .

If **Match All** was selected, the *Load Options* will display. If **Match One** was selected, the specific customer (for example) must now be selected before the *Load Options* are displayed.

Load Options



This option determines whether or not the printout will display the number of loads per product. The options are **On** or **Off**.

Press  or  to scroll up or down, then press .

The *Port Options* will display.

Port Options

Format	Description
Printer	Prints to the LOADRITE™ printer.
EDP	Captures data to a laptop or Data Module.

Press  or  to scroll up or down, then press .

When the port has been selected, the report will print.

7.2.6. Set Number of Copies

>  > *Print Menu > Copy*

This function sets the number of dockets to be printed at each clear event.

7.2.7. Print Data List

>  > *Print Menu > Data List*

This function prints out a list of all the *Data 1* names (for example, Customers) configured in the LOADRITE™ system. This function is normally only used to check the names when the list has been updated.

7.2.8. Print Product Names

>  > *Print Menu > Product Name*

This function prints out a list of all the product names configured in the LOADRITE™ system.

Tip: This function is normally only used to check the names when the list has been updated.

7.2.9. Print Volume Conversion Factors

>  > *Print Menu > Volume Conv*

This printing option is only available if *Volume Conversion Factors* functionality is enabled at installation.

This function prints out a list of all the product conversion factors configured in the LOADRITE™ Weighing System. This is normally only used when the list has been updated.

7.2.10. Print Standby Message

➤  > *Print Menu > Standby*

The LOADRITE™ weighing system normally displays the service contact details of your local LOADRITE™ distributor when the Indicator is put into *Standby* mode. These details can also be printed by selecting **Print Standby**.

7.2.11. Usage

➤  > *Print Menu > Usage*

Displays the amount of free storage space remaining in the LOADRITE™ Indicator internal storage. It also displays the time and date of the first saved event.

7.2.12. Reset

➤  > *Print Menu > Reset*

This function erases all data sorted in the LOADRITE™ Indicator. The time and date of the first entry along with the remaining free space is displayed, before the message **Storage clear?** is displayed.





▶ Press  to erase the data from memory.

Tip: We recommend that you erase the internal storage after reports are generated to prevent duplicate information being included in subsequent reports.

8. MAIN MENU

The *Main Menu* options that are available depend on options selected at installation.

The *Main Menu* provides options for configuring the LOADRITE™ Weighing System.

- ▶ To display the *Main Menu*, press  twice. Press  or  to scroll up or down, then press  to select an option.
- ▶ To exit the *Main Menu*, press .

Menu Option	Description
Setup...	Displays the <i>Install Menu</i> . ▶ For further information, contact your LOADRITE™ distributor.
Language	Select the language for the Indicator.
Clock	Displays the <i>Clock Menu</i> .
Contrast	Adjust the backlight contrast level.
Brightness	Adjust the backlight brightness level.
Scale #	Select the attachment.
Long Tot	View and clear the Long Total for the selected product.
Clear All	View and clear the Long Total for all products.
Auto-Add	Select whether or not Auto-Add is enabled.
Edit Password	Change the login PIN number.
Module	Displays the <i>Data Module</i> properties and performs a self-test.
Data Edit	Select a data value for the data field.
Data List	Edit data values.
Self Test	Runs a system self-test
Uplink	Allows the Indicator to communicate with the <i>LOADRITE™Toolbox</i> PC software

8.1. SETUP...

The *Install Menu* provides options for configuring the LOADRITE™ Indicator at installation. A security code is required to access this menu.

- ▶ For further information, contact your LOADRITE™ distributor.

8.2. LANGUAGE

The language can only be changed if *Language Edit* functionality has been enabled during installation.

Provides a list of available languages in which the LOADRITE™ Indicator can display screen names, fields, menu options and printed dockets.

- ▶ Select the preferred language, then press .

8.3. CLOCK



The time, date and year can only be changed if *Clock Edit* functionality has been enabled during installation.

You can set the time, date and year on the Indicator.



8.3.1. Setting the time

- 1) From the *Clock Menu* select **Time**, then press . The time will display with the cursor over the first digit.





- 2) Use the keypad to enter the time.
- 3) Press  or  to select **AM** or **PM**.
- 4) Press  to confirm the new time.

8.3.2. Setting the date



- 1) From the *Clock Menu* select **Date**, then press .
- 2) Use the keypad to enter the month and day.
- 3) Press **1-9** for **January** to **September**; Press **0** then **0** for **October**; Press **0** then **1** for **November**; Press **0** then **2** for **December**.
- 4) Press  to confirm the new date.

8.3.3. Setting the year

- 1) From the *Clock Menu* select **Year**, then press .
- 2) Use the keypad to enter the last two digits of the year. For example, press **1** then **1** for **2011**.
- 3) Press  to confirm the new year.



8.4. CONTRAST

Allows you to adjust the backlight contrast level for optimum visibility:

- 1) Press  or  to adjust the backlight contrast up or down.
- 2) Press  to save the contrast level.

8.5. BRIGHTNESS

Allows you to adjust the backlight brightness level for optimum visibility:

- 1) Press  or  to adjust the backlight brightness up or down.
- 2) Press  to save the brightness level.

8.6. SCALE

The Scale options are only available if *Multiple Scales* functionality has been enabled during installation.

This option enables the use of different load holders (for example, different types of bucket) on the excavator. The operator needs to select the correct scale for the attached implement.

Tip: You should perform a *Check Zero* after changing the attachment.

8.7. LONG TOTAL

Allows you to view and clear the long total for current products.

- ▶ For more information, see "View and clear the long total" on page 4-20.

8.8. CLEAR ALL

Allows you to clear the long total for all products.

- ▶ For more information, see "View and clear the long total" on page 4-20.

8.9. AUTO-ADD

The *Auto-Add toggle* functionality may or may not be available depending the configuration of your Indicator.

Controls whether or not the *Auto-Add* functionality is enabled.

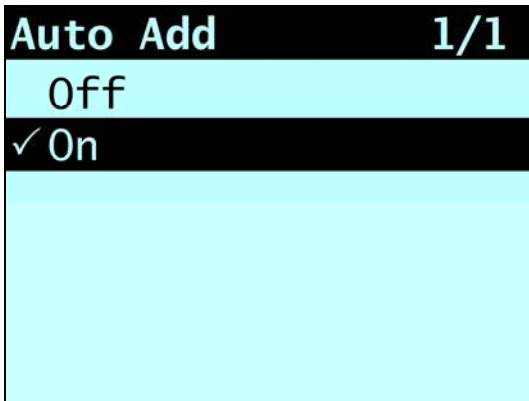

- ▶ Select either **On** or **Off**, then press .

8.10.EDIT PASSWORD

A password can only be edited if *Login* functionality has been enabled during installation.

Allows the PIN number of the current operator to be changed using the keypad.

- ▶ Enter the new PIN number using the keypad, then press .

8.11.MODULE





The *Module* option is only available if a LOADRITE™ Data Module is connected to the Indicator and *Data Logger* functionality has been correctly configured during installation.

This option performs the following functions before returning to the *Main Menu*:

- 1) Displays the software and hardware version of the Data Module.
- 2) Performs a self-test of the Data Module.
- 3) Displays amount of free data storage available on the Data Module.

8.12.DATA EDIT



Allows you to select a value for each data field:

- 1) Press  twice.
The *Main Menu* will display.
- 2) Select **Data Edit**, then press .
- 3) Use  or  to select the required data value for the data field, then press .
- 4) Repeat steps 2-3 until data values have been selected for all data fields.

8.13.DATA LIST



8.13.1. Adding a data value



Important: Data field values can only be entered using specific *Western Latin* characters, such as in English.





- 1) Press  twice.
The *Main Menu* will display.
- 2) Select **Data List**, then press .
The *Edit?* screen will display.



- 3) Complete the following:

If ...	Then ...
you would like to add a data value to the data field that is displayed	press  .
you would like to select a different data field	press  until the required data field is displayed, then press  .



- 4) Press .
The *Data Entry* screen will display.
- 5) Use the keypad to enter the data value, then press .
- 6) Complete the following:

If ...	Then ...
you would like to add another data value	▶ Go back to step 4.
you would like to select a different data field	▶ Press  .
	▶ press  until the required data field is displayed, then press  .
	▶ Go back to step 4.
you have finished editing data values	Press  twice to return to the <i>Main Menu</i> .

8.13.2. Editing a data field value



You can edit a data field value if required by using the *Data List* function.





Important: Data field values can only be entered using specific *Western Latin* characters, such as in English.

- 1) Press  twice.
The *Main Menu* will display.
- 2) Select **Data List**, then press .
The *Edit?* Screen will display.











- 3) Complete the following:

If ...	Then ...
you would like to edit a data value from the data field that is displayed	press  .
you would like to select a different data field	press  until the required data field is displayed, then press  .

- 4) Press  or  to scroll up or down the list of data values until the required data value is displayed, then press .
- 5) Use the keypad to edit the data value, then press .

Tip: Press  to clear the current value name.

- 6) Press .
- 7) Complete the following:

If ...	Then ...
you would like to edit another data value	<ul style="list-style-type: none"> ▶ press . ▶ Press  until the required data field is displayed, then press . ▶ Go back to step 4.
you would like to select a different data field	<ul style="list-style-type: none"> ▶ Press . ▶ press  until the required data field is displayed, then press . ▶ Go back to step 5.
you have finished editing data values	Press  twice to return to the <i>Main Menu</i> .

8.14.SELF TEST



This function tests various functions and the internal memory. All tests are run automatically when this option is selected. When the test has completed, the *Total* screen will display.

8.15.UPLINK

This option is used to upload a configuration file created using *LOADRITE™ Toolbox* via a EDP cable. The configuration file contains product names, data lists and settings.

- ▶ For information on creating a configuration file, refer to the *LOADRITE™ Toolbox User Manual*.

8.15.1. Uploading a configuration file via a EDP cable

- 1) When the **Upload Data?** message displays, press .
- 2) When the **Clear Data?** message displays, press .

9. APPENDIX A: SYSTEM SPECIFICATIONS

9.1. SUITABLE APPLICATIONS

The Indicator measures weight by sensing the hydraulic pressure required to lift a load with a hydraulic excavator.

9.2. WEIGHING ACCURACY

Typical accuracy is within 3% for most excavators. This may vary with different machine types, installation options, and the operating environment.

9.3. MINIMAL WEIGHING DELAY

Weighing delay is minimal, because the weighing function is carried out during a normal lift.

9.4. POWER REQUIREMENTS

Supply voltage	12 to 32V DC
Supply current	LOADRITE™ Indicator: 160mA typical, 350mA max. LOADRITE™ printer: 50mA standby, 4A peak.
Automatic transient suppression	Exceeds relevant SAE specifications for DC automotive power supply transients.

9.5. PHYSICAL SPECIFICATIONS

LCD display	Backlit.
Tactile keypad	Backlit. Numeric and special functions.
Weight	1.5 kg (3.2lb)
Dimensions	W145 x L240 x D110mm (5.7 x 9.4 x 4.3 in)

9.6. ENVIRONMENTAL SPECIFICATIONS

Operating temperature	-10°C to 50°C (14°F to 122°F)
Storage temperature	-50°C to 100°C (-58°F to 212°F)
Indicator	Protected to IP54.
Pressure transducer	Protected to IP69.

9.7. SIGNAL INPUTS AND OUTPUTS

Pressure transducer input	4 - 20mA (0-100%).
Sensor trigger inputs	PWM / PCM.
Serial communications	RS232C protocol to printer and LOADRITE™ Data Module.

9.8. CLOCK

Built-in clock	Hours, minutes, day, month, year.
----------------	-----------------------------------

9.9. AVAILABLE ACCESSORIES

LOADRITE™ printer	Dot matrix, 24 character columns.
Data Module	Provides electronic data collection.
Remote add button	For operator convenience.
Interlock system	To disable weighing under defined machine conditions.

A number of additional operating features can be enabled at the time of installation.

9.10. OUTPUT/INPUT CONNECTIONS

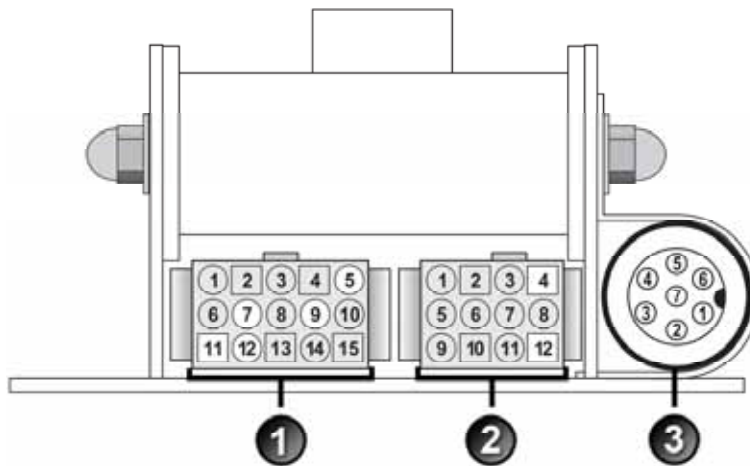

	Connection
1	Power / Control
2	Printer / Data Logger
3	Pressure Transducer

9.10.1. Power / Control

1. Negative supply (ground)	2. Positive supply
3. Remote button 2 (clear)	4. Remote button 1 (add)
5. Tilt sensor 1	6. Tilt sensor 3
7. Tilt sensor 2	8. +VAUX
9. Digital out	10. Boom position
11. Stick position	12. CAN hi
13. CAN lo	14. +V raw
15. Ground output	

9.10.2. Printer / Data Logger

1. Negative supply to printer	2. Positive supply to printer
3. +VAUX	4. RX2
5. TX2	6. Printer RS232 output
7. Printer busy input	8. LOADRITE™ Data Module RS232 input
9. LOADRITE™ Data Module RS232 output	10. Ground output
11. Boot	12. N.C.

9.10.3. Pressure Transducer

1. +VAUX	2. Return pressure input
3. Transducer current input	4. +VAUX
5. Lift pressure input	6. Shield
7. Ground	





10. APPENDIX B: SPAN CALIBRATION ADJUSTMENT

This function allows small changes to be made to the LOADRITE™ Weighing System calibration if the bucket is modified, or if no accurate test weight was available when the LOADRITE™ Weighing System was calibrated at installation time.

The adjustment is carried out by entering the total weight recorded at a weighbridge (scale house) and the corresponding total provided by the LOADRITE™ Indicator.

To perform the adjustment a security access code must be obtained from your LOADRITE™ installer.

CAUTION The LOADRITE™ Weighing System alters its calibration every time this function is used. It is important that this function is only used *once* with a given set of data. If the same weights are entered again, the LOADRITE™ Weighing System will over-correct and its accuracy will be seriously impaired.

- 1) Press  twice.
The *Main Menu* will display.
- 2) Select **Setup...**, then press .
- 3) Enter the security access code provided by the LOADRITE™ installer, then press .
- 4) Select **Calibration Menu**, then press .
- 5) Select **Adjust Span**, then press .
- 6) The **Adjust Span** message will display briefly and then the *LOADRITE Adjust Span* screen will display.



- 7) Enter the total weight provided by the LOADRITE™ Indicator, then press .

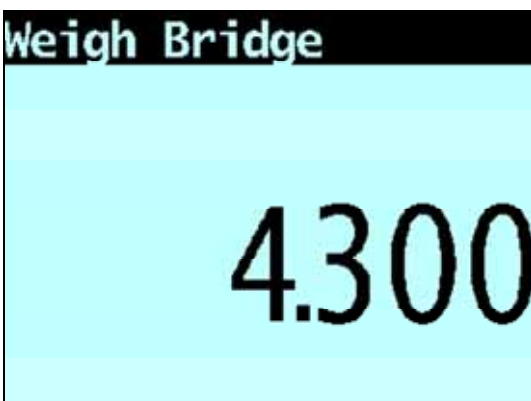

- 8) Enter the total weight provided by the weighbridge, then press .
- 9) The LOADRITE™ Indicator briefly displays the **Calibration Updated** message, and then returns to the *Calibration Menu*.

10.1.CHECKING THE ADJUSTMENT

The *Calibration Adjustment* can be checked by obtaining and comparing new LOADRITE™ and weighbridge values. If necessary, the *Calibration Adjustment* can be performed again using the new data.

IMPORTANT: All trucks and trailers should have tare weights confirmed for all loads to be checked. This ensures that a true weight can be established. Avoid split-weighing the truck and trailer.

11. APPENDIX C: ERROR MESSAGES

Error messages may be displayed for a variety of reasons as detailed below.

11.1.BUCKET LIMITS ERROR

The bucketload is lower than the minimum weight or exceeds the acceptable angle limits for the lift. Adjust the bucketload or angle of the bucket and reweigh it.

11.2.BUCKET STICK LIMITS ERROR

The following errors both apply:

- ▶ The stick angle is outside of the specified limits for weighing.
- ▶ The bucketload is lower than the minimum weight or exceeds the acceptable angle limits for the lift. Adjust the bucketload or angle of the bucket and reweigh it.

If this message appears regularly, contact your local LOADRITE™ distributor.

11.3.CHECK BUCKET

There is a fault in the bucket position sensor, or the connecting cable.

11.4.CHECK TILT 1

There is a fault in the tilt sensor closest to the slew center, or the connecting cable.

11.5.CHECK TILT 2

There is a fault in the tilt sensor furthest the slew center, or the connecting cable.

11.6.CHECK TRIGGER 1

There is a fault in the boom position sensor, or the connecting cable.

11.7.CHECK TRIGGER 2

There is a fault in the stick position sensor, or the connecting cable.

11.8.CHECK POWER

The power supply has reached an unstable level. Check that the power source is stable and between +12V and +32V.

11.9.CHECK TRANSDUCER

There is an error in the pressure transducer signal input. This indicates a fault in either the pressure transducer or the cable that connects the transducer.

11.10. CHECK TRIGGER

There is a fault in the one of the position sensors or the cables that connects them.

11.11. CHECK ZERO

The operator is automatically reminded to check zero.

11.12. LIFT NOT SMOOTH

The Indicator has detected that the bucket was not moving smoothly through the weighing zone and may have been accelerating or decelerating.

11.13. LIFT OVER RANGE

The lift pressure was too high. This indicates a fault in either the pressure transducer or the cable that connects the transducer.

11.14. LIFT SPEED TOO HIGH

The Indicator has detected that the bucket was moving too fast through the weighing zone, which did not give sufficient time to allow an accurate weight calculation to be made. This can be resolved by reducing the lifting speed.

11.15. LIFT UNDER RANGE

The lift pressure was too low. This indicates a fault in either the pressure transducer or the cable that connects the transducer.

11.16. MODULE DATA LOST

The Indicator has the ability to store data internally in the event that the LOADRITE™ Data Module is absent or full. This message indicates that the internal data storage is full and some data has been lost as a result.

CAUTION: You must install a new LOADRITE™ Data Module immediately to avoid further loss of data.

11.17. MODULE ERROR

The Indicator has detected an error when recording data on the LOADRITE™ Data Module. Check that the Data Module is securely connected to the Indicator.

11.18. MODULE FULL

The Indicator has detected that the LOADRITE™ Data Module is full. The Data Module should be removed and connected to MMS for the data to be transferred.

11.19. OVERLOAD

The lifted weight exceeds the full scale (capacity) setting. If the *Overload Error* is set during installation, overloaded weight cannot be added.

11.20. OVER TARGET

Adding the lifted weight will exceed the target value. The lifted weight can still be added by pressing .

Note: The *Auto-add* function will not automatically add over-target weight.

11.21. POOR LIFT

If a weighing error is close to, but not greater than, the tolerance limit, the LOADRITE™ Indicator displays this warning message. The weight can be added as usual.

11.22. PRINTER DISABLED

Print function has been disabled at installation.

11.23. PRINTER ERROR

There is a fault in the printer. Check that the printer is online and has paper.

11.24. RETURN OVER RANGE

The return pressure was too high. This indicates a fault in either the pressure transducer or the cable that connects the transducer.

11.25. RETURN UNDER RANGE

The return pressure was too low. This indicates a fault in either the pressure transducer or the cable that connects the transducer.

11.26. SLEW RPM TOO HIGH

The Indicator has detected that the measured slew speed has exceeded acceptable limits as the bucket load was being weighed. This can be resolved by slowing the slew of the Excavator when weighing the load.

11.27. STICK LIMITS ERROR

The stick angle is outside of the specified limits for weighing. If this message appears regularly, contact your local LOADRITE™ distributor.

11.28. TOO HEAVY, ZERO ABORTED

If the weight of material in the bucket is greater than 10% of full bucket capacity when  is pressed, the screen displays this message and does not alter any settings. This prevents any accidental zeroing of valid weights.

Note: If the bucket is empty and the message still occurs, there may be a fault in the system. The LOADRITE™ Weighing System should be checked and, if necessary, re-calibrated.

11.29. UNSTABLE LOAD

The lifting arm is bouncing significantly while weighing. This can happen if, for example, the bucket is lifted in a jerky manner.

11.30. WARM-UP LIFT

This message displays if the LOADRITE™ Indicator has been turned off for more than one hour, prompting a warm-up lift.

12. APPENDIX D: LEGAL INFORMATION

Disclaimer

Actronic Ltd operates a policy of on-going development. Please note that while every effort has been made to ensure that the data given in this document is accurate, due to continued product development, the information, figures, illustrations, tables, specifications, and schematics contained herein are subject to change without notice. Actronic Ltd does not warrant that this document is error-free. The screenshots and other presentations shown in this manual may differ from the actual screens and presentations generated by the actual product. All such differences are minor and the actual product will deliver the described functionality as presented in this document in all material respects. If you find any errors in the document, please report them to us in writing.

Actronic Ltd assumes no liability in connection with the use of any LOADRITE™ branded product.

Actronic Ltd is not responsible for any radio or TV interference caused by unauthorized modifications to this equipment. Such modifications could void the user's authority to operate the equipment.

Compliance

Domain	Applicable Standard
Immunity Standards (industrial)	IEC 61000-4-3 (ed1.2) Electromagnetic compatibility (EMC) - Part 4-3: Testing and measurement techniques - Radiated, radio-frequency, electromagnetic field immunity test (80% 1kHz Amplitude Modulated) from 80MHz to 1GHz 10V/m IEC 61000-4-3 (ed1.3) Electromagnetic compatibility (EMC) - Part 4-3: Testing and measurement techniques - Radiated, radio-frequency, electromagnetic field immunity test (80% 1kHz Amplitude Modulated) from 1.4GHz to 2GHz 3V/m IEC 61000-4-3 (ed1.4) Electromagnetic compatibility (EMC) - Part 4-3: Testing and measurement techniques - Radiated, radio-frequency, electromagnetic field immunity test (80% 1kHz Amplitude Modulated) from 2GHz to 2.7GHz 1V/m
Conducted	IEC 61000-4-6 (ed2.1) Electromagnetic compatibility (EMC) - Part 4-6: Testing and measurement techniques - Immunity to conducted disturbances, induced by radio-frequency fields
Fast Transients	IEC 61000-4-4 (ed2.1) Electromagnetic compatibility (EMC) - Part 4-4: Testing and measurement techniques - Electrical fast transient/burst immunity test +/-1KV (5/50 Tr/Th ns - 5kHz repetition)
ESD	IEC 61000-4-2 Electromagnetic compatibility (EMC) - Part 4-2: Testing and measurement techniques - Electrostatic discharge immunity test +/-4kV / Electrostatic Air Discharge +/-8kV
Electromagnetic compatibility (EMC)	EN/IEC/AS/NZS 61000-6-2:2005 Electromagnetic compatibility (EMC) - Part 6-2: Generic standards - Immunity for industrial environments EN/IEC 61000-6-4:2005 Electromagnetic compatibility (EMC) - Part 6-4: Generic Standards - Emission standard for industrial environments ANSI C63.4:2003 FCC Part 15 (A and B) - Radio Frequency Devices



Products with the CE marking comply with the Electromagnetic Compatibility Directive (2004/108/EC) issued by the Commission of the European Community. Compliance with this directives implies conformity to the following European Standards:

EN 61000-6-2:2005 Electromagnetic compatibility (EMC) - Part 6-2: Generic standards - Immunity for industrial environments

EN 61000-6-4:2005 Electromagnetic compatibility (EMC) - Part 6-4: Generic Standards - Emission standard for industrial environments

The Indicator is fully EMC (Electro-Magnetic Compatibility) compliant and is CE marked accordingly. A Declaration of Conformity, in accordance with the EMC Directive 89/336/EEC (and as amended) is available from Actronic Ltd on request.

Actronic Ltd cannot be held responsible for modifications made by the User and the consequences thereof, which may alter the conformity of the product with CE marking.

Hereby, Actronic Ltd, declares that this LOADRITE™ X-Weigh 2350 is in compliance with the essential requirements and other relevant provisions of Directive 2004/108/EC.

The Indicator is compliant with RoHS Directive 2002/95/EC which sets limits for the use of certain restricted hazardous substances. This directive states that "from 1st July 2006, new electrical and electronic equipment put on the market does not contain lead, mercury, cadmium, hexavalent chromium, polybrominated biphenyls (PBB) or polybrominated diphenyl ethers (PBDE)".

This device complies with part 15 of the FCC Rules. Operation is subject to the following two conditions: (1) This device may not cause harmful interference, and (2) this device must accept any interference received, including interference that may cause undesired operation.

WARNING: This product contains chemicals known to the State of California to cause cancer, birth defects or other reproductive harm. This Notice is being provided in accordance with California's Proposition 65.

Disposing of the LOADRITE™ Indicator

This electronic product is subject to the EU Directive 2002/96/EC for Waste Electrical and Electronic Equipment (WEEE) which requires the separate collection, treatment, recycling and environmentally-sound final disposal of waste of electrical and electronic equipment. As such, this product must not be disposed of at a municipal waste collection point.

Please refer to local regulations for directions on how to dispose of this product in an environmentally friendly manner.



13. APPENDIX E: GLOSSARY

A

Angle Sensor

An optional sensor included in the Ground Slope Compensation Kit which measures the tilt angle of the loader and compensates for the angle in calculations of load weight. Can be used in Legal for Trade software.

- ▶ See also *Ground Slope Compensation Kit* and *Legal for Trade*.

Auto-add

Automatically adds the lifted weight to the total weight every time a load is lifted.

Auto-target

A feature that allows you to select target weights for each truck. When a truck is selected on the Indicator, the target weight for that truck will automatically be used.

B

Bucket

The attachment on the excavator that holds the bulk material or load while it is being transferred.

D

Data Field

Customizable fields that allow you to label your weighing data to help you track and monitor your output, for example, by truck, customer, or docket.

Data Module

A memory device which connects to the Indicator to store payload and related data. The Data Module can then be connected to a PC running MMS software to transfer the data for the creation of productivity reports.

Display

A screen with adjustable backlighting for night and low-light operations. Used to display weight information and messages.

Docket

A printed record of a load.

- ▶ May also be known as *Ticket*.

G

Grand Total Mode

The mode used when loading different products to achieve a total weight. The grand total indicates the total weight of products loaded.

Ground Slope Compensation Kit

An upgrade kit required to enable the Ground Slope Compensation function on certain models of LOADRITE™ Indicator.

- ▶ See also *Angle Sensor* and *Legal For Trade*.

I

Indicator

The LOADRITE™ user interface installed in a loader or excavator which the operator uses to record bucket weights. When used with a belt scale, the term *Integrator* should be used.

Note: May also be known as *Console, Module, In-Cab Console, Loadrite, Loadrite Console, Head Unit, Clock, Computer, Scale*; however *Indicator* is the preferred term.

Interlock

Sensors which detect the back and forward positions of the bucket. Can be used in *Legal for Trade* software, where the bucket must be fully rolled back for weighing and rolled forward for emptying.

- ▶ See also *Legal For Trade*.

K

Keypad

A set of numeric or alphanumeric buttons on the Indicator which allow you to enter numbers, letters and other characters. Depending on the Indicator model, *Keypad* may also refer to other buttons along-side the numeric or alphanumeric buttons.

L

Legal for Trade

Certification by a local weights and measures authority to legally sell product from your loader or other scale.

Load

The amount of product added to a truck, or the act of adding product to a truck.

LOADRITE™ Weighing System

Refers to the entire LOADRITE™ hardware and software weighing system installed at a site, including the Indicator, transducers, sensors, modem, MMS software, etc.

- ▶ May also be referred to as *LOADRITE™ System*.

Long Total

The total amount of product loaded over a long period, such as a shift or day.

- ▶ See also *Short Total*.

M

MMS

Material Management System. PC software used to track productivity and create reports from data collected by LOADRITE™ Indicators.

Modem

A device used to transfer live payload and other data from the Indicator to a PC with MMS installed. There are two classes of modem:

- ▶ Cellular model, for example LD311
- ▶ Radio modem, for example LD100.

O

Operation Mode

Any mode that relates to the running total of accumulated weights, for example, *Total* or *Target* mode.

Operator

The person operating the excavator.

- ▶ Also known as *Excavator Driver* or *Excavator Operator*.

P

Pressure Transducer

A pressure sensor connected to the loader's hydraulic system in order to measure the hydraulic pressure required to lift a load.

Primary Product

The first item in a product recipe is referred to as the primary product.

Printer

An optional accessory mounted in the loader cab. It provides a paper record of the weighing information collected by the Indicator.

- ▶ See also *Docket* or *Ticket*.

Product

Material that comprises a load. For example, salt, coal, etc.

R

Remote Add Button

An additional **Add** button which is mounted in close proximity to the excavator controls and performs the same function as the **Add** button on the LOADRITE™ Indicator. The button enables the operator to add a load without having to remove their hands from the excavator controls.

S

Short Total

The running total amount of product loaded onto a truck or carriage. The Short Total amount will continue to accumulate until it is cleared using the *Clear* function.

- ▶ See also *Long total*.

Standby

A low-power mode which the Indicator should be set to between jobs, for example, when the operator is moving the excavator and does not need to weigh a load.

T

Target Mode

A mode used to enter a predetermined product target weight. The Indicator will calculate and display the amount of product required to reach the target. For each lift, the lift weight will be subtracted from the displayed amount until the target weight is reached.

- ▶ See also *Operation Mode*.

Ticket

A printed record of a load.

- ▶ May also be known as *Docket*.

Tip-off

The final bucket load adjustment, which allows you to tip a measured amount of the product from the final bucket to ensure an exact target weight is reached.

Transducer

- ▶ See *Pressure transducer*.

Trigger

A sensor which responds to the position of the lift arms, and informs the Indicator when to take a weight reading. LOADRITE™ weighing systems have three types of trigger: optical, rotary and magnetic.

Trigger Level

The point of the Weighing Zone where the weight reading is taken. The Trigger Level is approximately 3 feet (1 meter) above the stockpile or material being dug out and should be set every time the digging location changes.

W

Weighbridge

A platform scale for weighing vehicles.

- ▶ Also known as *Ground Scale*, *Scale House* and *Truck Scale*.

Weighing Zone

The range of motion that the excavator has when loading.

- ▶ See also *Trigger Level*.

Z

Zero/Zeroing

Sets the weight of the bucket to **0**. Zeroing is required to reset the weight of the bucket from time-to-time. This is to avoid inaccurate readings due to the build-up of material in the bucket which can occur when operators are dealing with wet or sticky materials.

- ▶ See also *Check zero*.

www.loadritescales.com

