



# Multi-functional Power Meter DPM-C530A User Manual

# Table of Contents

<b>1. Preface</b> .....	<b>2</b>
<b>2. Notes</b> .....	<b>3</b>
2.1 Safety Notes .....	3
2.2 Installation Environment .....	4
<b>3. Descriptions of Parts</b> .....	<b>5</b>
3.1 Operating Interface .....	5
3.2 Product Name Tag .....	5
3.3 Exterior and Dimensions .....	5
<b>4. Installation</b> .....	<b>7</b>
4.1 Installation Method .....	7
4.2 Basic Checks .....	9
<b>5. Wiring Diagrams</b> .....	<b>10</b>
5.1 Wiring on the Back .....	10
5.2 Descriptions of Wiring .....	11
<b>6. Panel Display and Settings</b> .....	<b>13</b>
6.1 Panel Display .....	13
6.2 General Operations .....	15
6.3 Setup Operations .....	16
<b>7. Parameters and Functions</b> .....	<b>22</b>
7.1 Overview of Parameters .....	22
<b>8. Messages of Abnormal Operations</b> .....	<b>72</b>
<b>9. Specifications</b> .....	<b>74</b>
9.1 Specifications .....	74
9.2 Communication Specifications .....	76
9.3 Modbus Communication .....	77
<b>Appendix</b> .....	<b>82</b>
Appendix 1: Selecting Accessories .....	82

# Preface

Thank you for choosing this product. This manual offers information related to installation of the DPM-C530A power meter. Before using the meter, please read this manual carefully to ensure proper use of this meter. Also, please place the manual at an easy-to-find location for reference at any time. Before you finish reading this manual, please observe the following notes: :

- No water vapor, corrosive and flammable gas shall be present in the installation environment.
- Follow the instructions on the diagram for wiring the device.
- Grounding must be performed correctly and properly according to provisions from related regulations on electric work currently effective in the country.
- Do not disassemble the meter or alter its wiring with power connected.
- With power on, do not touch the power-connecting area to avoid electric shock.

If you still experience issues in the use, please contact your distributor or our customer service center. As the product gets updated and improved, modifications on the specifications will be addressed in the newest version of manual obtainable by contacting your distributor or downloading from the Delta Electronics website ( <http://www.delta.com.tw/ia/> ) .



# Notes

## 2.1 Safety Notes

Always be aware of the following safety notes when installing, wiring, operating, maintaining, and checking the device.

---

### ◆ Notes on Installation



- » Install the power meter according to instructions on the manual. Otherwise, damage on the device might result.
- » It is forbidden to expose and use this product in a place present with matters, such as water vapor, corrosive and flammable gas. Otherwise, electric shock, fire, or explosion might result.
- » Do not install the meter in an environment with a temperature that exceeds range on the specification. Otherwise, inability of the meter to operate normally or damage on the meter might result.
- » Do not use the meter on an alarm console that might cause personnel injury or death, damage on the device, or system shutdown.

### ◆ Note on Wiring



- » Keep a good grounding on the grounded terminals, as improper grounding might cause abnormal communication, electric shock, or fire.

### ◆ Notes on Operation



- » Do not alter wiring with power turned on. Otherwise, electric shock or personnel injury might result.
- » Do not touch the panel with a sharp item. Otherwise, indentation on the panel might result, which causes the meter to not function normally.

### ◆ Maintenance and Check



- » Do not get to inside of the meter. Otherwise, electric shock might result.
- » Do not take the meter panel apart when the power is on. Otherwise, electric shock might result.
- » Do not touch the wiring terminals within 10 minutes after turning off power, as the remaining voltage might cause electric shock.
- » Do not block ventilation ducts when operating the meter. Otherwise, the meter will breakdown because of inadequate heat dissipation.

### ◆ Methods of Wiring



- » Do not use voltage that exceeds range specified for the meter. Otherwise, electric shock or fire might result.
- » When wiring, take apart the quick connector from the main meter body.
- » Connect only one cord on one plug on the quick connector.
- » For wrongfully forced unplug, recheck the connecting cord and restart.

### ◆ Wiring for Communication Circuits



- » Follow the standard specification on use of wires for communication wiring.
- » Length of communication wires should be within the specified standard.
- » Use correct grounding loop to avoid communication issues.
- » To avoid stronger noise interference that causes the meter to not operate normally, use an independent wiring slot to separate the communication cable for the meter from all power cords and motor power cords.

## 2.2 Installation Environment

Before installation, this product must be placed in its packaging box. If not used for a while, be sure to watch for the following when storing the meter, so that the product could be kept under the company's warranty coverage for future maintenance.

- Place the device in a dry location free of dust.
- Ambient temperature for the storage location must be within the range of -20° C to +70° C (-4° F to 158° F).
- Relative humidity for the storage location must be within the range of 5% to 95%, with no condensation.
- Avoid storing at an environment present with corrosive gas and liquid.
- Package properly and store on a rack or counter.
- Suitable installation environment for this product includes: place with no device that generates high amount of heat; place with no water drop, vapor, dust, and oily dust; place with no corrosive and flammable gas; place with no floating dust and metal particles; place with no shaking and interference from electromagnetic noise.

# Descriptions of Parts

## 3.1 Operating Interface

DPM-C530A uses a LCD display that exhibits four pieces of measurement information on each page. Diagram below is an illustration of the interface.

Descriptions:

- |                    |              |
|--------------------|--------------|
| A. Title           | F. Up key    |
| B. Area of display | G. Down key  |
| C. Pulse light     | H. Enter key |
| D. Fault light     |              |
| E. Menu key        |              |

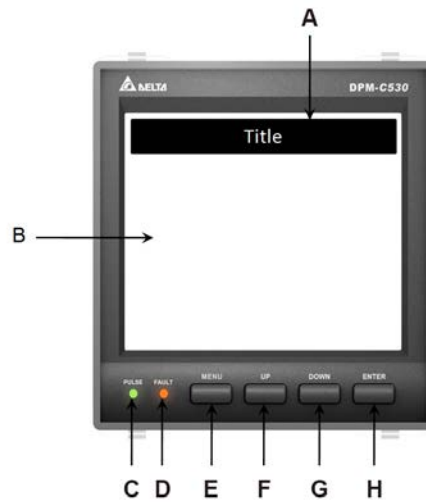

## 3.2 Product Name Tag

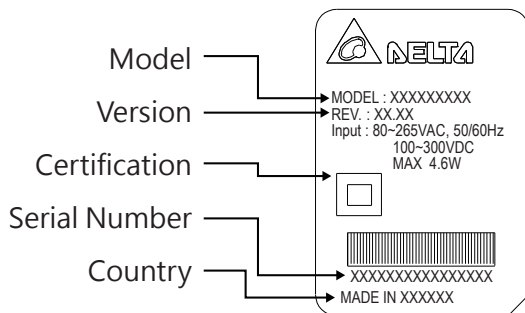

## 3.3 Exterior and Dimensions

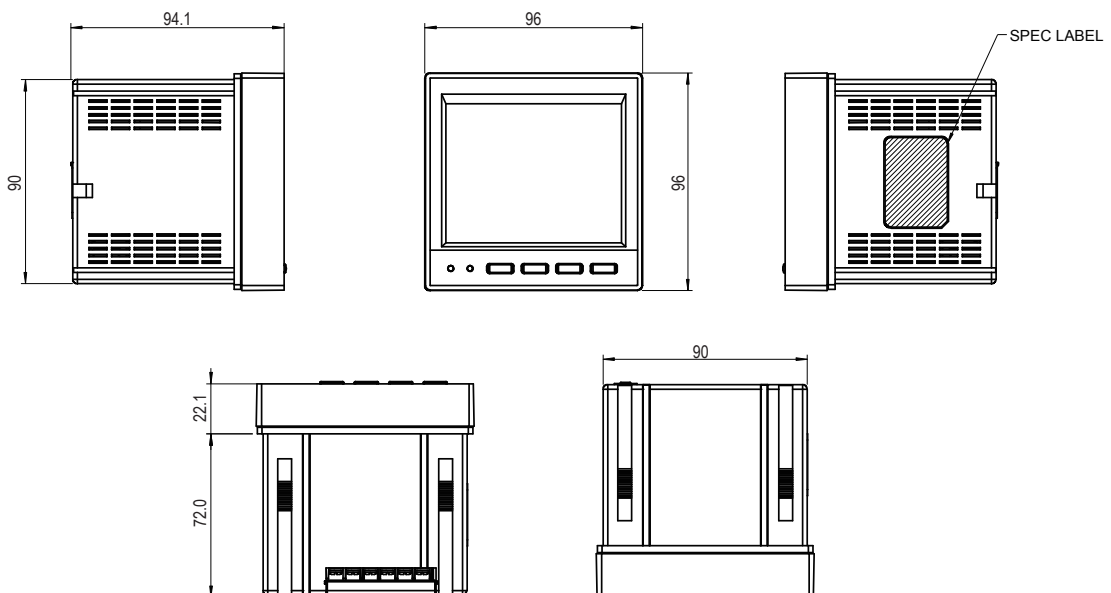

◆ Front

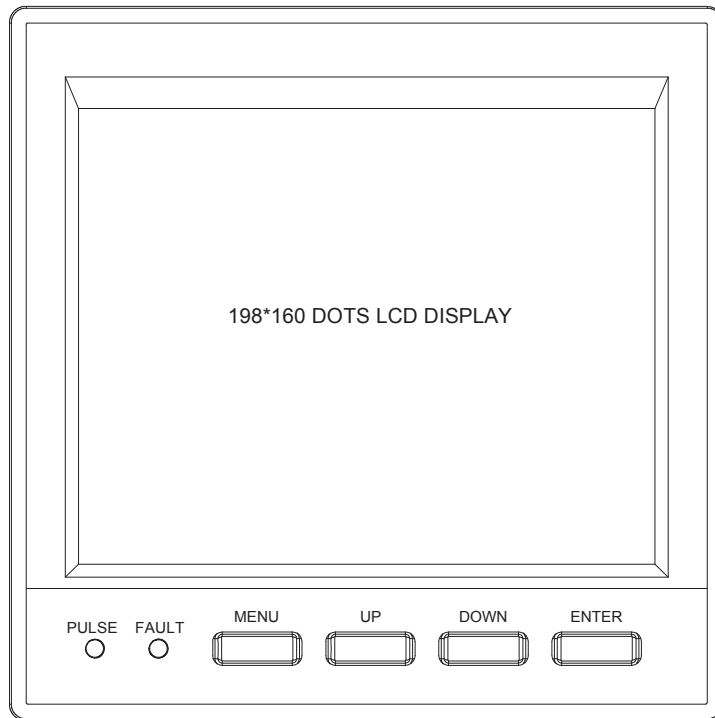

◆ Back

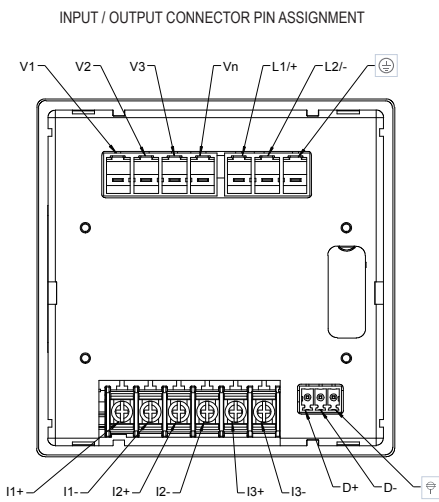

FUNCTION	PIN	VOLTAGE	CURRENT
MEASURED VOTAGE	V1	20V L-N ~ 400V L-N 35V L-L ~ 690V L-L	-
	V2		
	V3		
	Vn		
CONTROL POWER	L1/+	80 ~ 265 VAC 100 ~ 300 VDC	400mA MAX.
	L2/-		
	⊕		
MEASURED CURRENT	I1+	-	1A ~ 5A
	I1-		
	I2+		
	I2-		
	I3+		
	I3-		
RS-485	D+	-7 ~ +12 VDC	-
	D-		
	⊕		

# Installation

## 4.1 Installation Method

Note :

- The installation method should be based on instructions. Otherwise, breakdown would result.
- For better effectiveness of cooling cycles, sufficient space must be kept between adjacent objects and walls during the installation. Otherwise, imperfect cooling would result.
- Maximal thickness for the panel installed should not exceed 5 mm.

Illustration of Installation :

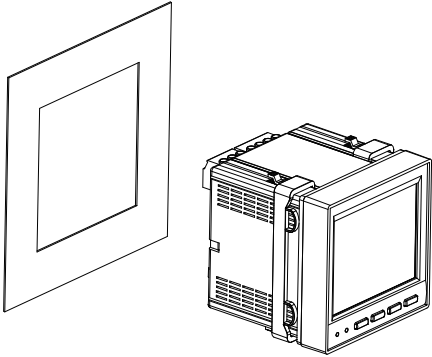
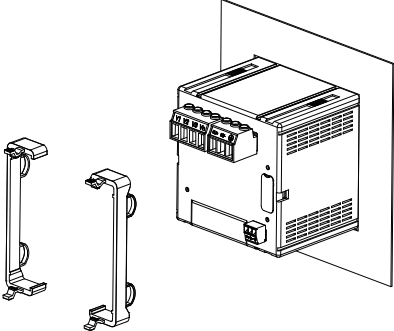
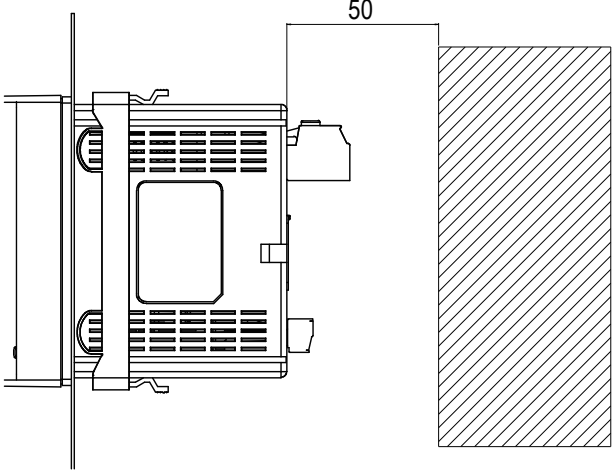
<p>Step 1: Open the square hole on the metal plate and then install the power meter.</p>	<p>Step 2: Install the fixing mount into the sliding slot and then push the meter in to touch the metal plate.</p>
	
<p>Step 3: During the installation, reserve a 50 mm-wide space behind the power meter for dissipating heat</p>	
 <p>單位 : mm</p>	



Dimensions of Panel Hole :

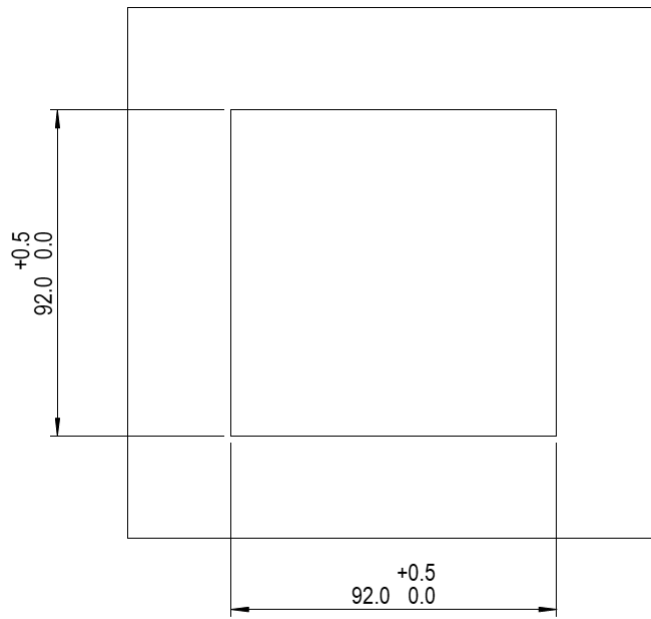

Panel Hole  
Thickness : 0.8~4.0mm

## 4.2 Basic Checks

Items Checked	Contents of Checks
General Check	<ul style="list-style-type: none"> <li>■ Regularly check for losing of the fixing mount at the location where the power meter and device are connected.</li> <li>■ Guard against entrance of foreign objects, such as oil, water, or metal powder at the heat dissipating holes. Guard against entrance of drill cut powders into the power meter.</li> <li>■ Should the power meter be installed at a place present with harmful gas or dust, guard against entrance of those matters into the meter.</li> </ul>
Pre-operation Check (not supplied with control power)	<ul style="list-style-type: none"> <li>■ Insulate the connecting spot of the wiring terminals.</li> <li>■ Communications wiring should be done properly, or abnormal operations might result.</li> <li>■ Check for presence of conducive and flammable objects, such as screws or metal pieces, in the power meter.</li> <li>■ Should electronic devices used near the power meter experience electromagnetic interference, tune with instruments to reduce electromagnetic interference.</li> <li>■ Check for correct voltage level for the power supplied to the power meter.</li> </ul>
Pre-running Check (supplied with control power)	<ul style="list-style-type: none"> <li>■ Check whether power indicator light is lit.</li> <li>■ Check whether communication between every device is normal.</li> <li>■ If there is any abnormal response from the power meter, contact your distributor or our customer service center.</li> </ul>

# Wiring Diagrams

## 5.1 Wiring on the Back

This chapter illustrates how the wiring on the back is done.

Note:

- To avoid electric shock, do not alter wiring when the power is on.
- As there is no power switch on the power meter, be sure to install a breaker switch on the power cord for the meter.

Recommended wiring materials are shown below:

Connecting Terminals	Wire Diameters	Screw Turning Torque
Functional Power	AWG 10~24	7.14 kgf-cm (0.7 N*m)
Measured Voltage	AWG 10~26	7.14 kgf-cm (0.7 N*m)
Measured Current	AWG 14~22	8.0 kgf-cm (0.79 N*m)
RS-485	AWG 14~28	2.04 kgf-cm (0.2 N*m)

RTwisted pair cables must be used in cabling for RS485 communication. When connecting multiple devices in series, the wiring method is displayed in the diagram below.

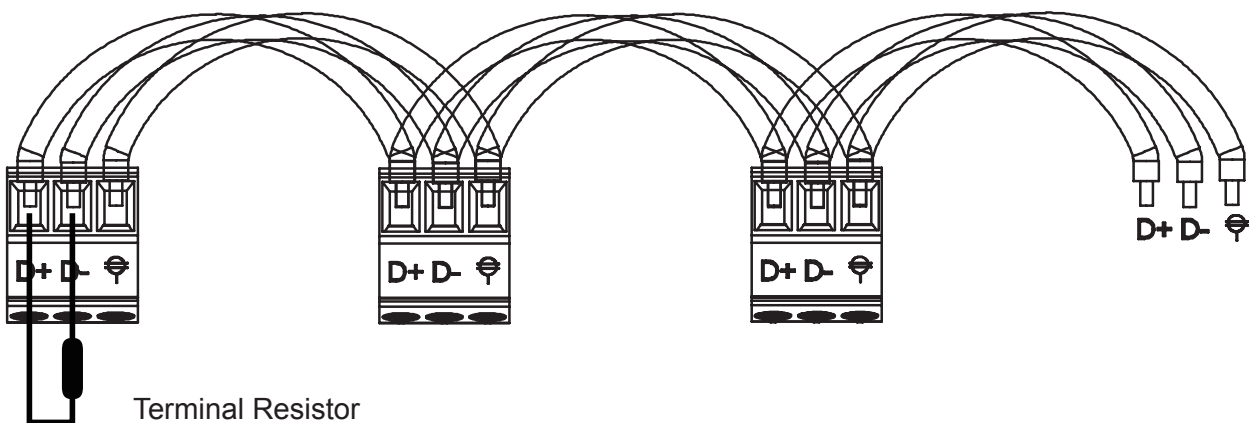

The D+ communication terminal for all devices should be connected on the same twisted pair cable. The D- terminals should be connected on the other twisted pair cable. The insulation net is grounded. The device on the end terminal needs to have terminal resistor installed on it.

## 5.2 Descriptions of Wiring

This chapter illustrates how wiring is done for this panel.

- Measured Voltage:

When measured voltage is higher than the rated specification (refer to Electrical Specification) for the device, use of an external potential transformer should be considered.

- Measured Current:

When measured current is higher than the rated specification (refer to Electrical Specification) for the device, use of an external current transformer should be considered.

- Supported Methods of Wiring:

<p>Diagram 5-1: One-phase two-wire, 1 CT</p>	<p>Diagram 5-2: One-phase three-wire, 2 CT</p>
<p>Diagram 5-3: Three-phase three-wire, Δ Delta-connection, 3 CT, No PT</p>	<p>Diagram 5-4: Three-phase three-wire, Δ Delta-connection, 2 CT, No PT</p>

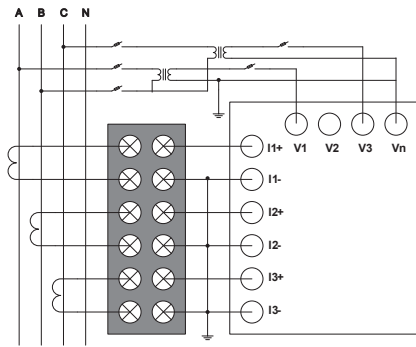

Diagram 5-5: Three-phase three-wire,  
 $\Delta$  Delta-connection, 3 CT, 2 PT

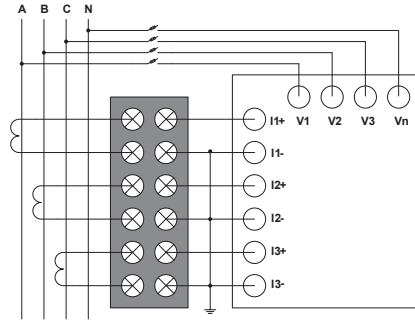

Diagram 5-6: Three-phase four-wire,  
 Y-connection, 3 CT, No PT

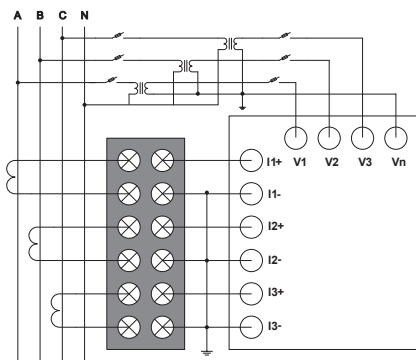

Diagram 5-7: Three-phase four-wire,  
 Y-connection, 3 CT, 3 PT

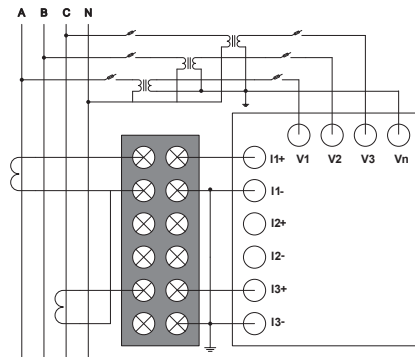

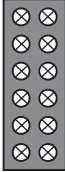



Diagram 5-8: Three-phase four-wire,  
 Y-connection, 2 CT, 3 PT

■ The following symbols are used in the diagram:

Symbol					
Description	Grounding	Current transformer	Terminal resistor	Potential or voltage transformer	Fuse

# Panel Display and Settings

## 6.1 Panel Display

### 6.1.1 Area of Display

DPM-C530A uses LCD display that exhibits four pieces of measurement information on each page. Diagram below is an illustration of the display panel:

Descriptions:

A	Title
B	Area of display
C	Pulse light
D	Fault light
E	Menu key
F	Up key
G	Down key
H	Enter key

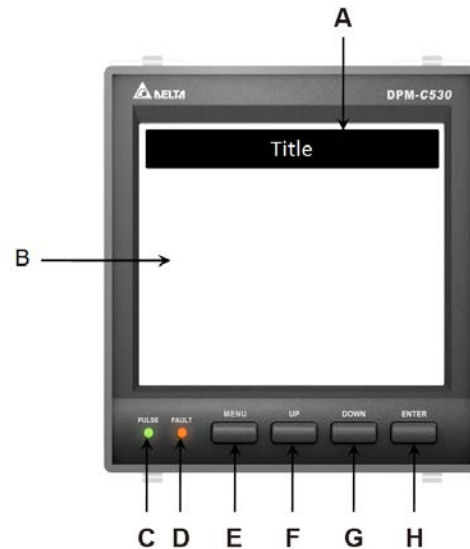

### 6.1.3 Descriptions of the Keys

Name of Key	General Mode	Configuration Mode
Menu key	Enter into Menu or return to previous page	Return without saving current settings
Up key	Move up to select an item or page	Increase numbers
Down key	Move down to select an item or page	Decrease numbers
Enter key	Enter into the selected item	Enter into the setting and move to the next location of setting

### 6.1.3 Menu Tree

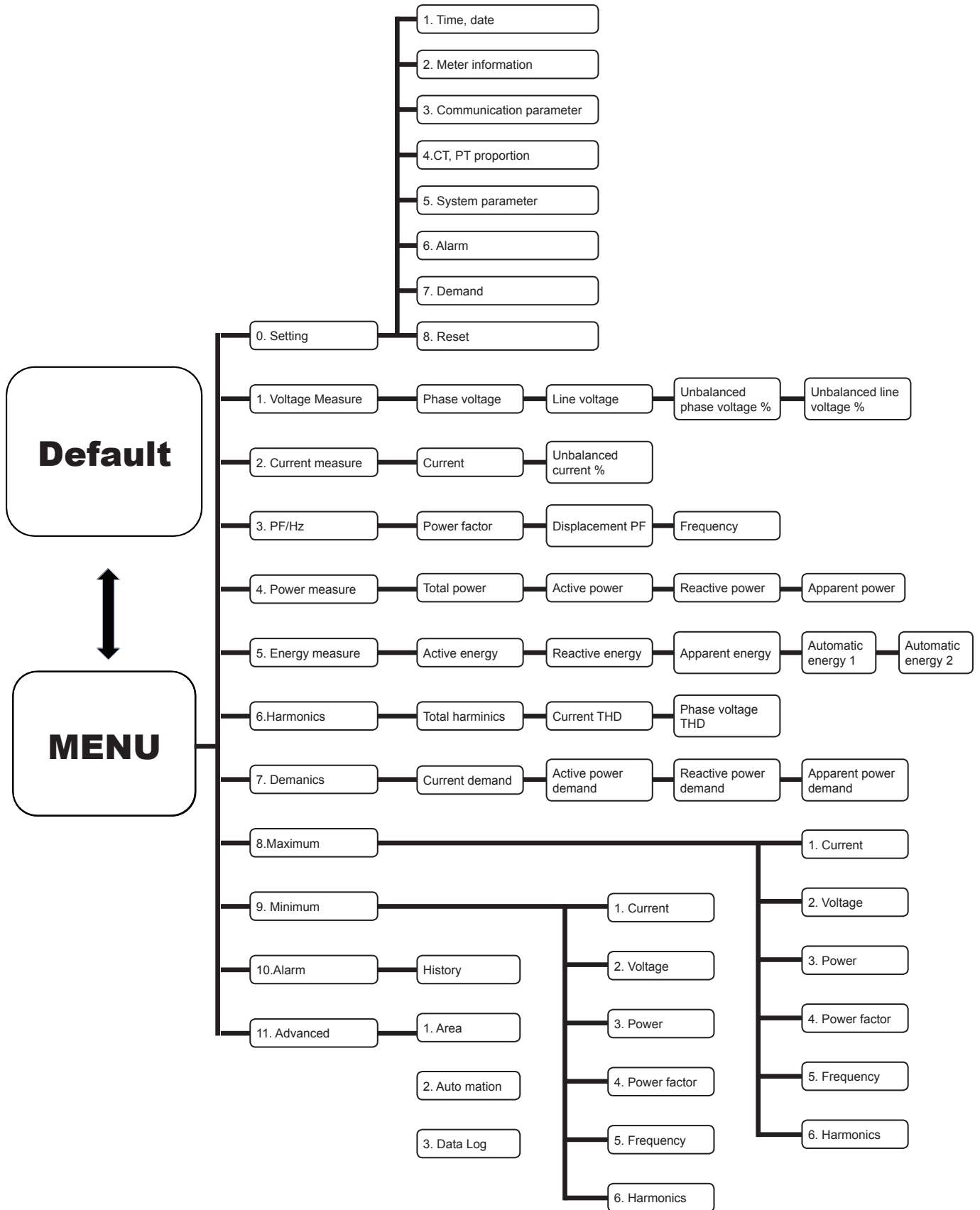

## 6.2 General Operations

### 6.2.1 Observing Measured Data

---

- **Voltage Measurement:**  
Parameter of voltage measured by the power meter, including phase voltage, line voltage, rate of phase voltage imbalance, rate of line voltage imbalance, etc
- **Current Measurement:**  
Parameter of currents measured by the meter, including phase/line voltage, rate of current imbalance, etc.
- **Power Factor, Frequency (PF ∙ Hz):**  
Power factor and parameter of frequency measured by the meter, including power factor, displacement power factor, frequency, etc.
- **Power Measurement:**  
Parameter of power measured by the meter, including active, reactive, and apparent power for every and combined phase.
- **Energy Measurement:**  
Parameter of electrical energy by the meter, including active, reactive, and apparent electrical energy on positive and opposite phases.
- **Harmonic:**  
Parameter of harmonic measured by the meter, including total harmonic for voltage and current, harmonic for voltage on every phase, harmonic for current on every phase.
- **Demand:**  
Parameter of demand measured by the meter, including demand for previous, current, forecast and peak current; active power; and reactive power.
- **Maximum:**  
Maximum parameter measured by the meter, including maximum value of voltage, current, power factor, frequency, power, harmonic, and demand.
- **Minimum:**  
Minimum parameter measured by the meter, including minimum value of voltage, current, power factor, frequency, power, harmonic, and demand.
- **Alarm: Parameter of alarms for the meter.**
  - (1) Press the Menu key until the menu appears.
  - (2) Select an item from 1~7 that you want to take a look at.
  - (3) Press the Up or Down key to switch between pages for every item of parameter.
  - (4) Press the Menu key to return to the menu page.

Example:

Assume having entered into the page of item 1. Measurement of Voltage, you will a page for phase voltage. Press the Down key to switch to the page for line voltage. Press the Down key again to switch to the page for the rate of phase voltage imbalance. Press the Down key again to switch to the page for the rate of line voltage imbalance. Press the Down key again to return to the phase voltage page. Otherwise, press the Up key to reverse the cycling order mentioned above.



## 6.3 Setup Operations

### 6.3.1 Time and Date Settings

---

- Time: Current time on the meter, including hour, Minute, second.
- Date: Current date on the meter, including last two digits of the year, Month, Day, and day of week.
- Steps to set up are as follows:
  - (1) Press Menu key until the menu appears.
  - (2) Select 0. Setup and press Enter key to enter into the setup menu.
  - (3) Select 1. Date/Time and press the Enter key to enter into options.
  - (4) Select Time or Date and press the Enter key to start setting up.
  - (5) When the option is highlighted, start setting up by using the Up and Down keys to select the numbers needed for the time and date.
  - (6) Press the Enter key to finish setting up for a number and move on to set up for the next number.
  - (7) Repeat steps (5)~(6) until finishing setup for the last number and press the Enter key. When the highlight disappears, setup is complete. If there is a need to cancel the setup in the middle, press the Menu key to return without saving the numbers that were just set.
  - (8) After completing or cancelling the setup, press the Menu key again to return to the setup menu.

### 6.3.2 Communication Settings

---

- Address:  
Range of address for the device is 1~254, with the broadcast address of 255 and factory default of 1.
- Protocol:  
Mode of communication transmission, with a selection from RTU (factory default) and ASCII.
- Baud Rate:  
Speed of communication transmission, with the factory default of 9600 kbps.
- Data Bit:  
Length of packet data, with a selectable range of 7 and 8 bits; however, only 8 bits (factory default) is selectable under RTU mode.
- Parity:  
Odd and even checking bit for communication, with a selection from None (factory default), Even, and Odd.
- Stop Bit:  
Signal for completion of packet transmission, with a selection from 1 and 2 bit(s) (factory default: 1 bit).
- Steps to set up are as follows:
  - (1) Press Menu key until the menu appears.
  - (2) Select 0. Setup and press Enter key to enter into the setup menu.

- (3) Select 3. Communication and press the Enter key to enter into options.
- (4) Select Address and press the Enter key to start setting up for the address.
- (5) When the option is highlighted, start setting up by using the Up and Down keys to select the numbers needed.
- (6) Press the Enter key to finish setting up for a number and move on to set up for the next number.
- (7) Repeat steps (5)~(6) until finishing setup for the last number and press the Enter key. When the highlight disappears, setup is complete. If there is a need to cancel the setup in the middle, press the Menu key to return without saving the numbers that were just set.
- (8) Select Protocol and press the Enter key to start setting up for communication mode.
- (9) When the option is highlighted, start setting up by using the Up and Down keys to select the mode needed, such as RTU or ASCII.
- (10) Press the Enter key to complete. When the highlight disappears, setup is complete. If there is a need to cancel the setup in the middle, press the Menu key to return without saving the mode that was just selected.
- (11) Setup for Baud rate, data bit, parity, and stop bit all follow the steps mentioned above.
- (12) After completing or cancelling the setup, press the Menu key again to return to the setup menu.

### 6.3.3 Settings for Potential and Current Transformers

---

- Primary-side current transformer (CT1): Ampere for the primary-side current transformer, with a selectable range of 1~9999 A (factory default: 1 A).
- Secondary-side current transformer (CT2): Ampere for the secondary-side current transformer, with a selection of 1 and 5 A (factory default: 1 A).
- Primary-side potential transformer (PT1): Voltage for the primary-side potential transformer, with a selectable range of 1~9999 V (factory default: 1 V).
- Secondary-side potential transformer (PT2): Voltage for the secondary-side potential transformer, with a selectable range of 1~9999 V (factory default: 1 V).
- Steps to set up are as follows:
  - (1) Press Menu key until the menu appears.
  - (2) Select 0. Setup and press Enter key to enter into the setup menu.
  - (3) Select 4. Transformer Ratio and press the Enter key to enter into options.
  - (4) Select CT1 and press the Enter key to start setting up for current transformer on the primary side.
  - (5) When the option is highlighted, start setting up by using the Up and Down keys to select the numbers needed.
  - (6) Press the Enter key to finish setting up for a number and move on to set up for the next number.
  - (7) Repeat steps (5)~(6) until finishing setup for the last number and press the Enter key. When the highlight disappears, setup is complete. If there is a need to cancel the setup in the middle, press the Menu key to return without saving the numbers that were just set.

(8) When the setup is finished, other parameters could be set. The steps start from step 5 mentioned above.

(9) After completing or cancelling the setup, press the Menu key again to return to the setup menu.

### 6.3.4 Settings for System Parameters

---

■ **Language:**

Language displayed on the operating interface of the meter. Selectable languages are English (factory default) and Simplified Chinese.

■ **Backlight:**

Brightness of LCD backlight on the meter, with a selection of 100% (factory default), 50%, and 25%.

■ **Timeout:**

Time to maintain brightness of LCD backlight on the meter. With 100% selected, the backlight always remains bright. With 50% and 25% selected, power saving mode is on with a time set for the backlight (factory default is 30 seconds). Once the time is up, the backlight is turned off. Touching the keys turns on the backlight with a brightness based on the percentage selected.

■ **Power System:**

Selection of wiring method for the system, with a selection of one-phase two-wire, one-phase three-wire, three-phase three-wire, three-phase four-wire (factory default).

■ **Phase:**

For the phase A wire connected to phase C, reversing to phase C wire connected to phase A does not require re-wiring. Conversion is done by directly selecting this parameter. Selectable modes are ABC (factory default) and CBA.

■ **Number of CTs:**

Numbers of current transformers on the system. 0, 1, 2, 3 current transformers are selectable. The default setting of current transformers is 3.

■ **Number of PTs:**

Numbers of potential transformers on the system. 0, 2, 3 potential transformers are selectable. The default setting of potential transformers is 3.

■ **Steps to set up are as follows:**

(1) Press Menu key until the menu appears.

(2) Select 0. Setup and press Enter key to enter into the setup menu.

(3) Select 5. System and press the Enter key to enter into options.

(4) Select Language and press the Enter key to start setting up for language.

(5) When the option is highlighted, start setting up by using the Up and Down keys to select the mode needed.

(6) Press the Enter key to complete. When the highlight disappears, setup is complete. If there is a need to cancel the setup in the middle, press the Menu key to return without saving the mode that was just selected.

- (7) Setup for backlight brightness, method of wiring、CT 數、PT 數 and phase sequence reversal all follow the steps mentioned above.
- (8) Select Timeout and press the Enter key to start setting up for timeout.
- (9) When the option is highlighted, start setting up by using the Up and Down keys to select the numbers needed.
- (10) Press the Enter key to finish setting up for a number and move on to set up for the next number.
- (11) Repeat steps (9)~(10) until finishing setup for the last number and press the Enter key. When the highlight disappears, setup is complete. If there is a need to cancel the setup in the middle, press the Menu key to return without saving the numbers that were just set.
- (12) After completing or cancelling the setup, press the Menu key again to return to the setup menu

### 6.3.5 Alarm Settings

---

- Alarm:  
Whether this alarm is enabled or disabled (factory default).
- Upper:  
When the threshold set on the meter is exceeded, an alarm will be generated. The factory default is 0.
- Timeout:  
When the threshold set on the meter is exceeded and the time delay set is overdue, an alarm will be generated. The factory default is 0.
- Lower:  
When the threshold set on the meter falls short, the alarm will be cancelled. The factory default is 0.
- Timeout:  
When the threshold set on the meter falls short and the time delay set is overdue, the alarm will be cancelled. The factory default is 0.
- Steps to set up are as follows:
  - (1) Press Menu key until the menu appears.
  - (2) Select 0. Setup and press Enter key to enter into the setup menu.
  - (3) Select 6. Alarm and press the Enter key to enter into options.
  - (4) Select the setup item needed and press the Enter key to enter into the option.
  - (5) Select Alarm and press the Enter key to start setting up.
  - (6) When the option is highlighted, start setting up by using the Up and Down keys to select the mode needed.
  - (7) Press the Enter key to complete. When the highlight disappears, setup is complete. If there is a need to cancel the setup in the middle, press the Menu key to return without saving the mode that was just selected.
  - (8) Select Upper and press the Enter key to start setting up for timeout.
  - (9) When the option is highlighted, start setting up by using the Up and Down keys to select the numbers needed.

- (10) Press the Enter key to finish setting up for a number and move on to set up for the next number.
- (11) Repeat steps (9)~(10) until finishing setup for the last number and press the Enter key. When the highlight disappears, setup is complete. If there is a need to cancel the setup in the middle, press the Menu key to return without saving the numbers that were just set.
- (12) Select Timeout and press the Enter key to start setting up for timeout.
- (13) When the option is highlighted, start setting up by using the Up and Down keys to select the numbers needed.
- (14) Press the Enter key to finish setting up for a number and move on to set up for the next number.
- (15) Repeat steps (13)~(14) until finishing setup for the last number and press the Enter key. When the highlight disappears, setup is complete. If there is a need to cancel the setup in the middle, press the Menu key to return without saving the numbers that were just set.
- (16) For Lower and Timeout below, the steps to set up for them are the same as those from (8)~(15).
- (17) For other alarm options, the steps to set up for them are the same as those from (4)~(16).
- (18) After completing or cancelling the setup, press the Menu key twice to return to the setup menu.

### 6.3.6 Settings for Demands

---

- Method: There is only one mode to calculate fixed interval on the meter.
- Interval: Time interval to calculate for the demand, with a selectable range of 1~99 min (factory default is 1 min).
- Steps to set up are as follows:
  - (1) Press Menu key until the menu appears.
  - (2) Select 0. Setup and press Enter key to enter into the setup menu.
  - (3) Select 7. Demand and press the Enter key to enter into options.
  - (4) Select the setup item needed and press the Enter key to enter into the option.
  - (5) Select Interval and press the Enter key to start setting up.
  - (6) When the option is highlighted, start setting up by using the Up and Down keys to select the numbers needed.
  - (7) Press the Enter key to finish setting up for a number and move on to set up for the next number.
  - (8) Repeat steps (6)~(7) until finishing setup for the last number and press the Enter key. When the highlight disappears, setup is complete. If there is a need to cancel the setup in the middle, press the Menu key to return without saving the numbers that were just set.
  - (9) After completing or cancelling the setup, press the Menu key again to return to the setup menu.

### 6.3.7 Restore Settings

---

- Default: Restores settings on the meter to factory default.
- Energy: Resets to zero for the value of electrical energy accumulated on the meter and that calculated without a meter-checking personnel.
- Demand: Resets to zero for the currents calculated by the meter, value of power demand, and logged time and date.
- Alarm: Clears away all alarm logs detected on the meter.
- MaxMin: Clears away all records of maximum and minimum values logged on the meter.
- Data Log: Clears away all historical data logs that are stored in the memory on the meter.
- Clear All: Restores all settings on the meter to factory default and clears away all historical data logs.
- Steps to set up are as follows:
  - (1) Press Menu key until the menu appears.
  - (2) Select 0. Setup and press Enter key to enter into the setup menu.
  - (3) Select 8. Reset and press the Enter key to enter into options.
  - (4) Select the setup item needed and press the Enter key to enter into the option.
  - (5) Press the Enter key to start setting up.
  - (6) When the option is highlighted, start setting up by using the Up and Down keys to select the mode needed.
  - (7) Press the Enter key to complete. When the highlight disappears, setup is complete. If there is a need to cancel the setup in the middle, press the Menu key to return without saving the mode that was just selected.
  - (8) Repeat steps (6)~(7) until finishing setup for the last number and press the Enter key. When the highlight disappears, setup is complete. If there is a need to cancel the setup in the middle, press the Menu key to return without saving the numbers that were just set.
  - (9) After completing or cancelling the setup, press the Menu key again to return to the setup menu.

# Parameters and Functions

## 7.1 Overview of Parameters

Modbus Address	Item Communicated	Range	Data Type	Unit	Data Size (Byte)	Read (R) / Write (W)
<b>0. System Parameter: 0001 ~ 00FF</b>						
1	Current date on meter	year: 00~99 month: 1~12	byte	year, month	2	R / W
2		day: 1~31, week: Sun. – Sat.	byte	day, week	2	R / W
3	Current time on meter	hour: 00~24 minute: 00~60	byte	hour and minute	2	R / W
4		second: 00~60	byte	second	1	R / W
5	Meter constant	3200	Uint	P/kWh	2	R
6	Meter model	0: None 1: DPM-C530A	byte		1	R
7	Total time on power	day: 0~65535	byte	day	2	R
8		hour: 00~24 minute: 00~60	byte	hour and minute	1	R
9	Firmware version number	0.0000 ~ 9.9999	Uint		2	R
A	Last write-in date on firmware	year: 00~99 month : 1~12	byte	year, month	2	R
B		day: 1~31	byte	day	1	R
C	Positive and opposite phase sequence	0: ABC 1: CBA	byte		1	R / W
D	Method of wiring for electric system	0: 3φ4W 1: 3φ3W 2: 1φ2W 3: 1φ3W	byte		1	R / W
E	Value of current on primary-side current transformer (A)	1 ~ 9999	Uint		2	R / W
F	Value of current on secondary-side current transformer (A)	0: 1A 1: 5A 2: 2.5A	byte		1	R / W
10	Multiplier on primary-side potential transformer	1 ~ 9999	Uint		2	R / W
11	Multiplier on secondary-side potential transformer	1 ~ 9999	Uint		2	R / W
12	Quantity of Transformer	0 : 3CT3PT 1 : 3CT2PT 2 : 3CT0PT 3 : 2CT3PT 4 : 2CT2PT 5 : 2CT0PT 6 : 1CT3PT 7 : 1CT2PT 8 : 1CT0PT 9 : 0CT3PT 10 : 0CT2PT 11 : 0CT0PT	byte		1	R / W
13	Language	0: English 1: Traditional Chinese 2: Simplify Chinese	byte		1	R / W
14	Power-saving mode (second)	0~99	byte	sec	1	R / W

15	Screen brightness	0: 100% 1: 50% 2: 25%	byte		1	R / W
16	Baud Rate	0: 9600, 1: 19200, 2: 38400	byte	bps	1	R / W
17	Communication mode	0: ASCII 1: RTU	byte		1	R / W
18	Data bit	0: 8 1: 7	byte		1	R / W
19	Parity	0: None 1: Even 2: Odd	byte		1	R / W
1A	Stop bit	0: 1 1: 2	byte		1	R / W
1B	Meter address	0 ~ 255	byte		1	R / W
1C	Reset parameters on meter	0: None 1: Reset factory default 2: Reset value of energy 3: Reset value of demand 4: Clear alarm logs and times 5: Reset maximum and minimum values 6: Clear saved logs 7: Clear all values	byte		1	W
1D	Demand (method of calculation)	0: block	byte		1	R
1E	Time interval for demand (min)	0 ~ 60	byte	minute	1	R / W
<b>Alarm - Over Current</b>						
1F	Alarm Enable	0: Disable 1: Enable	byte		1	R / W
20	Pickup setpoint (currents exceeding this value(A), alarm generated)	0.000~99999.999	Float	A	4	R / W
21						
22	Pickup time delay (triggering delayed)	0~99	byte	s	2	R / W
23	Dropout setpoint (currents lower than this value (A), alarm cleared)	0.000~99999.999	Float	A	4	R / W
24						
25	Dropout time delay (restoration delayed)	0~99	byte	s	2	R / W
<b>Alarm - Under Current</b>						
26	Alarm Enable	0: Disable 1: Enable	byte		1	R / W
27	Pickup setpoint (currents lower than this value (A), alarm generated)	0.000~99999.999	Float	A	4	R / W
28						
29	pickup time delay (triggering delayed)	0~99	byte	s	2	R / W
2A	Dropout setpoint (currents exceeding this value (A), alarm cleared)	0.000~99999.999	Float	A	4	R / W
2B						
2C	Dropout time delay (restoration delayed)	0~99	byte	s	2	R / W
<b>Alarm - Over Neutral Current</b>						
2D	Alarm Enable	0: Disable 1: Enable	byte		1	R / W



2E	Pickup setpoint (currents exceeding this value(A), alarm generated)	0.000~99999.999	Float	A	4	R / W
2F						
30	pickup time delay (triggering delayed)	0~99	byte	s	2	R / W
31	Dropout setpoint (currents lower than this value (A), alarm cleared)	0.000~99999.999	Float	A	4	R / W
32						
33	Dropout time delay (restoration delayed)	0~99	byte	s	2	R / W
<b>Alarm - Over Line Voltage</b>						
34	Alarm Enable	0: Disable 1: Enable	byte		1	R / W
35	pickup setpoint (voltage exceeding this value (V), alarm generated)	0.000~99999.999	Float	V	4	R / W
36						
37	pickup time delay (triggering delayed)	0~99	byte	s	2	R / W
38	dropout setpoint (voltage lower than this value (V), alarm cleared)	0.000~99999.999	Float	V	4	R / W
39						
3A	dropout time delay (restoration delayed)	0~99	byte	s	2	R / W
<b>Alarm - Under Line Voltage</b>						
3B	Alarm Enable	0: Disable 1: Enable	byte		1	R / W
3C	pickup setpoint (voltage lower than this value (V), alarm generated)	0.000~99999.999	Float	V	4	R / W
3D						
3E	pickup time delay (triggering delayed)	0~99	byte	s	2	R / W
3F	dropout setpoint (voltage exceeding this value (V), alarm cleared)	0.000~99999.999	Float	V	4	R / W
40						
41	dropout time delay (restoration delayed)	0~99	byte	s	2	R / W
<b>Alarm - Over Phase Voltage</b>						
42	Alarm Enable	0: Disable 1: Enable	byte		1	R / W
43	pickup setpoint (voltage exceeding this value (V), alarm generated)	0.000~99999.999	Float	V	4	R / W
44						
45	pickup time delay (triggering delayed)	0~99	byte	s	2	R / W
46	dropout setpoint (voltage lower than this value (V), alarm cleared)	0.000~99999.999	Float	V	4	R / W
47						
48	dropout time delay (restoration delayed)	0~99	byte	s	2	R / W
<b>Alarm - Under Phase Voltage</b>						
49	Alarm Enable	0: Disable 1: Enable	byte		1	R / W
4A	pickup setpoint (voltage lower than this value (V), alarm generated)	0.000~99999.999	Float	V	4	R / W
4B						

4C	pickup time delay (triggering delayed)	0~99	byte	s	2	R / W
4D	dropout setpoint (voltage exceeding this value (V), alarm cleared)	0.000~99999.999	Float	V	4	R / W
4E						
4F	dropout time delay (restoration delayed)	0~99	byte	s	2	R / W
<b>Alarm - Over Voltage Unbalance</b>						
50	Alarm Enable	0: Disable 1: Enable	byte		1	R / W
51	pickup setpoint (voltage unbalance exceeding this value (V), alarm generated)	0.000~99999.999	Float	%	4	R / W
52						
53	pickup time delay (triggering delayed)	0~99	byte	s	2	R / W
54	dropout setpoint (voltage unbalance lower than this value (V), alarm cleared)	0.000~99999.999	Float	%	4	R / W
55						
56	dropout time delay (restoration delayed)	0~99	byte	s	2	R / W
<b>Alarm - Over Current Unbalance</b>						
57	Alarm Enable	0: Disable 1: Enable	byte		1	R / W
58	pickup setpoint (current unbalance exceeding this value (A), alarm generated)	0.000~99999.999	Float	%	4	R / W
59						
5A	pickup time delay (triggering delayed)	0~99	byte	s	2	R / W
5B	dropout setpoint (current unbalance lower than this value (A), alarm cleared)	0.000~99999.999	Float	%	4	R / W
5C						
5D	dropout time delay (restoration delayed)	0~99	byte	s	2	R / W
<b>Alarm - Over Active Power</b>						
5E	Alarm Enable	0: Disable 1: Enable	byte		1	R / W
5F	pickup setpoint (active power exceeding this value (kW), alarm generated)	0.000~99999.999	Float	kW	4	R / W
60						
61	pickup time delay (triggering delayed)	0~99	byte	s	2	R / W
62	dropout setpoint (active power lower than this value (kW), alarm cleared)	0.000~99999.999	Float	kW	4	R / W
63						
64	dropout time delay (restoration delayed)	0~99	byte	s	2	R / W
<b>Alarm - Over Reactive Power</b>						
65	Alarm Enable	0: Disable 1: Enable	byte		1	R / W
66	pickup setpoint (reactive power exceeding this value (kVAR), alarm generated)	0.000~99999.999	Float	kVAR	4	R / W
67						
68	pickup time delay (triggering delayed)	0~99	byte	s	2	R / W

69	dropout setpoint (reactive power lower than this value (kVAR), alarm cleared)	0.000~99999.999	Float	kVAR	4	R / W
6A						
6B	dropout time delay (restoration delayed)	0~99	byte	s	2	R / W
<b>Alarm - Over Apparent Power</b>						
6C	Alarm Enable	0: Disable 1: Enable	byte		1	R / W
6D	pickup setpoint (apparent power exceeding this value (kVA), alarm generated)	0.000~99999.999	Float	kVA	4	R / W
6E						
6F	pickup time delay (triggering delayed)	0~99	byte	s	2	R / W
70	dropout setpoint (apparent power lower than this value (kVA), alarm cleared)	0.000~99999.999	Float	kVA	4	R / W
71						
72	dropout time delay (restoration delayed)	0~99	byte	s	2	R / W
<b>Alarm - Lead PF</b>						
73	Alarm Enable	0: Disable 1: Enable	byte		1	R / W
74	pickup setpoint (active power factor lower than this value, alarm generated)	0.000~99999.999	Float		4	R / W
75						
76	pickup time delay (triggering delayed)	0~99	byte	s	2	R / W
77	dropout setpoint (active power factor exceeding this value, alarm cleared)	0.000~99999.999	Float		4	R / W
78						
79	dropout time delay (restoration delayed)	0~99	byte	s	2	R / W
<b>Alarm - Lag PF</b>						
7A	Alarm Enable	0: Disable 1: Enable	byte		1	R / W
7B	pickup setpoint (active power factor lower than this value, alarm generated)	0.000~99999.999	Float		4	R / W
7C						
7D	pickup time delay (triggering delayed)	0~99	byte	s	2	R / W
7E	dropout setpoint (active power factor exceeding this value, alarm cleared)	0.000~99999.999	Float		4	R / W
7F						
80	dropout time delay (restoration delayed)	0~99	byte	s	2	R / W
<b>Alarm - Lead Displacement PF</b>						
81	Alarm Enable	0: Disable, 1: Enable	byte		1	R / W
82	pickup setpoint (displacement power factor lower than this value, alarm generated)	0.000~99999.999	Float		4	R / W
83						
84	pickup time delay (triggering delayed)	0~99	byte	s	2	R / W
85	dropout setpoint (displacement power factor exceeding this value, alarm cleared)	0.000~99999.999	Float		4	R / W
86						

87	dropout time delay (restoration delayed)	0~99	byte	s	2	R / W
<b>Alarm - Lag Displacement PF</b>						
88	Alarm Enable	0: Disable 1: Enable	byte		1	R / W
89	pickup setpoint (displacement power factor lower than this value, alarm generated)	0.000~99999.999	Float		4	R / W
8A						
8B	pickup time delay (triggering delayed)	0~99	byte	s	2	R / W
8C	dropout setpoint (displacement power factor exceeding this value, alarm cleared)	0.000~99999.999	Float		4	R / W
8D						
8E	dropout time delay (restoration delayed)	0~99	byte	s	2	R / W
<b>Alarm - Over Current Demand</b>						
8F	Alarm Enable	0: Disable 1: Enable	byte		1	R / W
90	pickup setpoint (current demand exceeds this value (A), alarm generated)	0.000~99999.999	Float	A	4	R / W
91						
92	pickup time delay (triggering delayed)	0~99	byte	s	2	R / W
93	dropout setpoint (current demand is lower than this value (A), alarm cleared)	0.000~99999.999	Float	A	4	R / W
94						
95	dropout time delay (restoration delayed)	0~99	byte	s	2	R / W
<b>Alarm - Over Active Power Demand</b>						
96	Alarm Enable	0: Disable 1: Enable	byte		1	R / W
97	pickup setpoint (active power demand exceeds this value (kW), alarm generated)	0.000~99999.999	Float	kW	4	R / W
98						
99	pickup time delay (triggering delayed)	0~99	byte	s	2	R / W
9A	dropout setpoint (active power demand is lower than this value (kW), alarm cleared)	0.000~99999.999	Float	kW	4	R / W
9B						
9C	dropout time delay (restoration delayed)	0~99	byte	s	2	R / W
<b>Alarm - Over Reactive Power Demand</b>						
9D	Alarm Enable	0: Disable 1: Enable	byte		1	R / W
9E	pickup setpoint (reactive power demand exceeds this value (kVAR), alarm generated)	0.000~99999.999	Float	kVAR	4	R / W
9F						
A0	pickup time delay (triggering delayed)	0~99	byte	s	2	R / W
A1	dropout setpoint (reactive power demand is lower than this value (kVAR), alarm cleared)	0.000~99999.999	Float	kVAR	4	R / W
A2						
A3	dropout time delay (restoration delayed)	0~99	byte	s	2	R / W

<b>Alarm - Over Apparent Power Demand</b>						
A4	Alarm Enable	0: Disable 1: Enable	byte		1	R / W
A5	pickup setpoint (apparent power demand exceeds this value (kVA), alarm generated)	0.000~99999.999	Float	kVA	4	R / W
A6						
A7	pickup time delay (triggering delayed)	0~99	byte	s	2	R / W
A8	dropout setpoint (apparent power lower than this value (kVA), alarm cleared)	0.000~99999.999	Float	kVA	4	R / W
A9						
AA	dropout time delay (restoration delayed)	0~99	byte	s	2	R / W
<b>Alarm - Over Frequency</b>						
AB	Alarm Enable	0: Disable 1: Enable	byte		1	R / W
AC	pickup setpoint (frequency exceeding this value (Hz), alarm generated)	0.000~99999.999	Float	Hz	4	R / W
AD						
AE	pickup time delay (triggering delayed)	0~99	byte	s	2	R / W
AF	dropout setpoint (frequency lower than this value (Hz), alarm cleared)	0.000~99999.999	Float	Hz	4	R / W
B0						
B1	dropout time delay (restoration delayed)	0~99	byte	s	2	R / W
<b>Alarm - Under Frequency</b>						
B2	Alarm Enable	0: Disable 1: Enable	byte		1	R / W
B3	pickup setpoint (frequency lower than this value (Hz), alarm generated)	0.000~99999.999	Float	Hz	4	R / W
B4						
B5	pickup time delay (triggering delayed)	0~99	byte	s	2	R / W
B6	pickup setpoint (frequency exceeding this value (Hz), alarm generated)	0.000~99999.999	Float	Hz	4	R / W
B7						
B8	dropout time delay (restoration delayed)	0~99	byte	s	2	R / W
<b>Alarm - Over Voltage THD</b>						
B9	Alarm Enable	0: Disable 1: Enable	byte		1	R / W
BA	pickup setpoint (voltage THD exceeding this value, alarm generated)	0.000~99999.999	Float	%	4	R / W
BB						
BC	pickup time delay (triggering delayed)	0~99	byte	s	2	R / W
BD	dropout setpoint (voltage THD lower than this value (kW), alarm cleared)	0.000~99999.999	Float	%	4	R / W
BE						
BF	dropout time delay (restoration delayed)	0~99	byte	s	2	R / W
<b>Alarm - Over Current THD</b>						
C0	Alarm Enable	0: Disable 1: Enable	byte		1	R / W

C1	pickup setpoint (current THD exceeding this value, alarm generated)	0.000~99999.999	Float	%	4	R / W
C2						
C3	pickup time delay (triggering delayed)	0~99	byte	s	2	R / W
C4	dropout setpoint (current THD lower than this value (kW), alarm cleared)	0.000~99999.999	Float	%	4	R / W
C5						
C6	dropout time delay (restoration delayed)	0~99	byte	s	2	R / W
<b>Alarm - Phase Loss</b>						
C7	Alarm Enable	0: Disable 1: Enable	byte		1	R / W
C8	pickup setpoint (phase lower than this value, alarm generated)	0.000~99999.999	Float	V	4	R / W
C9						
CA	pickup time delay (triggering delayed)	0~99	byte	s	2	R / W
CB	dropout setpoint (phase exceeding this value, alarm cleared)	0.000~99999.999	Float	V	4	R / W
CC						
CD	dropout time delay (restoration delayed)	0~99	byte	s	2	R / W
<b>Alarm - Over DUI</b>						
CE	Alarm Enable	0: Disable 1: Enable	byte		1	R / W
CF	pickup setpoint (DUI exceeding this value, alarm generated)	0.000~99999.999	Float	kW	4	R / W
D0						
D1	pickup time delay (triggering delayed)	0~99	byte	s	2	R / W
D2	dropout setpoint (DUI lower than this value, alarm cleared)	0.000~99999.999	Float	kW	4	R / W
D3						
D4	dropout time delay (restoration delayed)	0~99	byte	s	2	R / W
<b>Alarm - Over EUI</b>						
D5	Alarm Enable	0: Disable 1: Enable	byte		1	R / W
D6	pickup setpoint (EUI exceeding this value, alarm generated)	0.000~99999.999	Float	kWh	4	R / W
D7						
D8	pickup time delay (triggering delayed)	0~99	byte	s	2	R / W
D9	dropout setpoint (EUI lower than this value, alarm cleared)	0.000~99999.999	Float	kWh	4	R / W
DA						
DB	dropout time delay (restoration delayed)	0~99	byte	s	2	R / W
<b>Alarm - Meter Reset</b>						
DC	Alarm Enable	0: Disable 1: Enable	byte		1	R / W
<b>Alarm - Phase Rotation</b>						
DD	Alarm Enable	0: Disable 1: Enable	byte		1	R / W

**1. Power Meter Parameters: 0100 - 01FF**

100	Phase A voltage	0.000~99999.999	Float	V	4	R
101						
102	Phase B voltage	0.000~99999.999	Float	V	4	R
103						
104	Phase C voltage	0.000~99999.999	Float	V	4	R
105						
106	Average value of phase voltage	0.000~99999.999	Float	V	4	R
107						
108	AB-line voltage	0.000~99999.999	Float	V	4	R
109						
10A	BC-line voltage	0.000~99999.999	Float	V	4	R
10B						
10C	CA-line voltage	0.000~99999.999	Float	V	4	R
10D						
10E	Average value of line voltage	0.000~99999.999	Float	V	4	R
10F						
110	Unbalanced voltage on phase A	0.00~99.99	Float	%	4	R
111						
112	Unbalanced voltage on phase B	0.00~99.99	Float	%	4	R
113						
114	Unbalanced voltage on phase C	0.00~99.99	Float	%	4	R
115						
116	Unbalanced phase-voltage	0.00~99.99	Float	%	4	R
117						
118	Unbalanced voltage on line AB	0.00~99.99	Float	%	4	R
119						
11A	Unbalanced voltage on line BC	0.00~99.99	Float	%	4	R
11B						
11C	Unbalanced voltage on line CA	0.00~99.99	Float	%	4	R
11D						
11E	Unbalanced line-voltage	0.00~99.99	Float	%	4	R
11F						
120	Phase A current	0.000~99999.999	Float	A	4	R
121						

122	Phase B current	0.000~99999.999	Float	A	4	R
123						
124	Phase C current	0.000~99999.999	Float	A	4	R
125						
126	Average current on three phases	0.000~99999.999	Float	A	4	R
127						
128	Natural current	0.000~99999.999	Float	A	4	R
129						
12A	Unbalanced current on phase A	0.00~99.99	Float	%	4	R
12B						
12C	Unbalanced current on phase B	0.00~99.99	Float	%	4	R
12D						
12E	Unbalanced current on phase C	0.00~99.99	Float	%	4	R
12F						
130	Unbalanced current	0.00~99.99	Float	%	4	R
131						
132	Total active power factor	0.00000~1.00000 (positive : lag negative : lead)	Float	+: lagging, -: leading	4	R
133						
134	Active power factor on phase A	0.00000~1.00000 (positive : lag negative : lead)	Float		4	R
135						
136	Active power factor on phase B	0.00000~1.00000 (positive : lag negative : lead)	Float		4	R
137						
138	Active power factor on phase C	0.00000~1.00000 (positive : lag negative : lead)	Float		4	R
139						
13A	Total displacement power factor	0.00000~1.00000 (positive : lag negative : lead)	Float	+: lagging, -: leading	4	R
13B						
13C	Displacement power factor on phase A	0.00000~1.00000 (positive : lag negative : lead)	Float		4	R
13D						
13E	Displacement power factor on phase B	0.00000~1.00000 (positive : lag negative : lead)	Float		4	R
13F						
140	Displacement power factor on phase C	0.00000~1.00000 (positive : lag negative : lead)	Float		4	R
141						
142	Frequency	0.00~99.99	Float	Hz	4	R
143						
144	Total instantaneous active power	0.000~99999.999	Float	kW	4	R
145						



146	Instantaneous active power on phase A	0.000~99999.999	Float	kW	4	R
147						
148	Instantaneous active power on phase B	0.000~99999.999	Float	kW	4	R
149						
14A	Instantaneous active power on phase C	0.000~99999.999	Float	kW	4	R
14B						
14C	Total instantaneous reactive power	0.000~99999.999	Float	kVAR	4	R
14D						
14E	Instantaneous reactive power on phase A	0.000~99999.999	Float	kVAR	4	R
14F						
150	Instantaneous reactive power on phase B	0.000~99999.999	Float	kVAR	4	R
151						
152	Instantaneous reactive power on phase C	0.000~99999.999	Float	kVAR	4	R
153						
154	Instantaneous apparent power	0.000~99999.999	Float	kVA	4	R
155						
156	Instantaneous apparent power on phase A	0.000~99999.999	Float	kVA	4	R
157						
158	Instantaneous apparent power on phase B	0.000~99999.999	Float	kVA	4	R
159						
15A	Instantaneous apparent power on phase C	0.000~99999.999	Float	kVA	4	R
15B						
15C	Positive active electric energy on three phases	0x00000000~0xFFFFFFFF	Uint	Wh	4	R
15D						
15E	Opposite active electric energy on three phases	0x00000000~0xFFFFFFFF	Uint	Wh	4	R
15F						
160	Positive reactive electric energy on three phases	0x00000000~0xFFFFFFFF	Uint	VARh	4	R
161						
162	Opposite reactive electric energy on three phases	0x00000000~0xFFFFFFFF	Uint	VARh	4	R
163						
164	Positive apparent electric energy on three phases	0x00000000~0xFFFFFFFF	Uint	VAh	4	R
165						
166	Opposite apparent electric energy on three phases	0x00000000~0xFFFFFFFF	Uint	VAh	4	R
167						
168	Positive active electric energy on three phases + Opposite active electric energy on three phases	0x00000000~0xFFFFFFFF	Uint	Wh	4	R
169						

16A	Positive active electric energy on three phases - Opposite active electric energy on three phases	0x80000001 ~ 0x7FFFFFFF (negative for 2's complement)	int	Wh	4	R
16B						
16C	Positive reactive electric energy on three phases + Opposite reactive electric energy on three phases	0x00000000~0xFFFFFFFF	Uint	VARh	4	R
16D						
16E	Positive reactive electric energy on three phases - Opposite reactive electric energy on three phases	0x80000001 ~ 0x7FFFFFFF (negative for 2's complement)	int	VARh	4	R
16F						
170	Positive apparent electric energy on three phases + Opposite apparent electric energy on three phases	0x00000000~0xFFFFFFFF	Uint	VAh	4	R
171						
172	Positive apparent electric energy on three phases - Opposite apparent electric energy on three phases	0x80000001 ~ 0x7FFFFFFF (negative for 2's complement)	int	VAh	4	R
173						
174	Total harmonic distortion for current on phase A	0.000~999.999	Float	%	4	R
175						
176	Total harmonic distortion for current on phase B	0.000~999.999	Float	%	4	R
177						
178	Total harmonic distortion for current on phase C	0.000~999.999	Float	%	4	R
179						
17A	Total harmonic distortion on neutral current	0.000~999.999	Float	%	4	R
17B						
17C	Total harmonic distortion for voltage on phase A	0.000~999.999	Float	%	4	R
17D						
17E	Total harmonic distortion for voltage on phase B	0.000~999.999	Float	%	4	R
17F						
180	Total harmonic distortion for voltage on phase C	0.000~999.999	Float	%	4	R
181						
182	Total harmonic distortion for voltage on line AB	0.000~999.999	Float	%	4	R
183						
184	Total harmonic distortion for voltage on line BC	0.000~999.999	Float	%	4	R
185						
186	Total harmonic distortion for voltage on line CA	0.000~999.999	Float	%	4	R
187						
188	Total harmonic distortion for current	0.000~999.999	Float	%	4	R
189						
18A	Total harmonic distortion for voltage	0.000~999.999	Float	%	4	R
18B						

18C	Present demand for current on three phases	0.000 ~ 99999.999	Float	A	4	R
18D						
18E	Previous average demand for current on three phases	0.000 ~ 99999.999	Float	A	4	R
18F						
190	Estimated required current for 3-phase balance	0.000 ~ 99999.999	Float	A	4	R
191						
192	Peak demand for current on three phases	0.000 ~ 99999.999	Float	A	4	R
193						
194	Date of peak demand for current on three phases	year: 00~99 month: 1~12	byte	year month	2	R
195		day: 1~31	byte	day	1	R
196	Time of peak demand for current on three phases	hour: 00~24 minute: 00~60	byte	hour minute	2	R
197		second: 00~60	byte	second	1	R
198	Present demand for positive active power on three phases	0.000 ~ 99999.999	Float	kW	4	R
199						
19A	Previous demand for positive active power on three phases	0.000 ~ 99999.999	Float	kW	4	R
19B						
19C	Estimated peak value of 3-phase active power in positive direction	0.000 ~ 99999.999	Float	kW	4	R
19D						
19E	Peak demand for positive active power on three phases	0.000 ~ 99999.999	Float	kW	4	R
19F						
1A0	Date of peak demand for positive active power on three phases	year: 00~99 month: 1~12	byte	year month	2	R
1A1		day: 1~31	byte	day	1	R
1A2	Time of peak demand for positive active power on three phases	hour: 00~24 minute: 00~60	byte	hour minute	2	R
1A3		second: 00~60	byte	second	1	R
1A4	Present demand for positive reactive power on three phases	0.000 ~ 99999.999	Float	kVAR	4	R
1A5						
1A6	Previous demand for positive reactive power on three phases	0.000 ~ 99999.999	Float	kVAR	4	R
1A7						
1A8	Estimated peak value of 3-phase reactive power in positive direction	0.000 ~ 99999.999	Float	kVAR	4	R
1A9						
1AA	Peak demand for positive reactive power on three phases	0.000 ~ 99999.999	Float	kVAR	4	R
1AB						
1AC	Date of peak demand for positive reactive power on three phases	year: 00~99 month: 1~12	byte	year month	2	R
1AD		day: 1~31	byte	day	1	R

1AE	Time of peak demand for positive reactive power on three phases	hour: 00~24 minute: 00~60	byte	hour minute	2	R
1AF		second: 00~60	byte	second	1	R
1B0	Present demand for positive apparent power on three phases	0.000 ~ 99999.999	Float	kVA	4	R
1B1						
1B2	Previous demand for positive apparent power on three phases	0.000 ~ 99999.999	Float	kVA	4	R
1B3						
1B4	Estimated peak value of 3-phase apparent power in positive direction	0.000 ~ 99999.999	Float	kVA	4	R
1B5						
1B6	Peak demand for positive apparent power on three phases	0.000 ~ 99999.999	Float	kVA	4	R
1B7						
1B8	Date of peak demand for positive apparent power on three phases	year: 00~99 month: 1~12	byte	year month	2	R
1B9		day: 1~31	byte	day	1	R
1BA	Time of peak demand for positive apparent power on three phases	hour: 00~24 minute: 00~60	byte	hour minute	2	R
1BB		second: 00~60	byte	second	1	R
1BC	DUI	0.000 ~ 99999.999	Float	kW/m2	4	R
1BD						
1BE	EUI	0.000 ~ 4294967295.000	Float	kWh/m2	4	R
1BF						
1C0	Positive active electric energy on three phases in interval	0x00000000~0xFFFFFFFF	Uint	Wh	4	R
1C1						
1C2	Opposite active electric energy on three phases in interval	0x00000000~0xFFFFFFFF	Uint	Wh	4	R
1C3						
1C4	Positive reactive electric energy on three phases in interval	0x00000000~0xFFFFFFFF	Uint	Wh	4	R
1C5						
1C6	Opposite reactive electric energy on three phases in interval	0x00000000~0xFFFFFFFF	Uint	Wh	4	R
1C7						
<b>2. Maximum Value: 0200 - 02FF</b>						
200	Maximum value of voltage on line AB	0.000 ~ 99999.999	Float	V	4	R
201						
202	Date for maximum value of voltage on line AB	year: 00~99 month: 1~12	byte	year month	2	R
203		day: 1~31	byte	day	1	R
204	Time for maximum value of voltage on line AB	hour: 00~24 minute: 00~60	byte	hour minute	2	R
205		second: 00~60	byte	second	1	R
206	Maximum value of voltage on line BC	0.000 ~ 99999.999	Float	V	4	R
207						

208	Date for maximum value of voltage on line BC	year: 00~99 month: 1~12	byte	year month	2	R
209		day: 1~31	byte	day	1	R
20A	Time for maximum value of voltage on line BC	hour: 00~24 minute: 00~60	byte	hour minute	2	R
20B		second: 00~60	byte	second	1	R
20C	Maximum value of voltage on line CA	0.000 ~ 99999.999	Float	V	4	R
20D						
20E	Date for maximum value of voltage on line CA	year: 00~99 month: 1~12	byte	year month	2	R
20F		day: 1~31	byte	day	1	R
210	Time for maximum value of voltage on line CA	hour: 00~24 minute: 00~60	byte	hour minute	2	R
211		second: 00~60	byte	second	1	R
212	Maximum value of voltage on phase A	0.000 ~ 99999.999	Float	V	4	R
213						
214	Date for maximum value of voltage on phase A	year: 00~99 month: 1~12	byte	year month	2	R
215		day: 1~31	byte	day	1	R
216	Time for maximum value of voltage on phase A	hour: 00~24 minute: 00~60	byte	hour minute	2	R
217		second: 00~60	byte	second	1	R
218	Maximum value of voltage on phase B	0.000 ~ 99999.999	Float	V	4	R
219						
21A	Date for maximum value of voltage on phase B	year: 00~99 month: 1~12	byte	year month	2	R
21B		day: 1~31	byte	day	1	R
21C	Time for maximum value of voltage on phase B	hour: 00~24 minute: 00~60	byte	hour minute	2	R
21D		second: 00~60	byte	second	1	R
21E	Maximum value of voltage on phase C	0.000 ~ 99999.999	Float	V	4	R
21F						
220	Date for maximum value of voltage on phase C	year: 00~99 month: 1~12	byte	year month	2	R
221		day: 1~31	byte	day	1	R
222	Time for maximum value of voltage on phase C	hour: 00~24 minute: 00~60	byte	hour minute	2	R
223		second: 00~60	byte	second	1	R
224	Maximum value of current on phase A	0.000 ~ 99999.999	Float	A	4	R
225						
226	Date for maximum value of current on phase A	year: 00~99 month: 1~12	byte	year month	2	R
227		day: 1~31	byte	day	1	R
228	Time for maximum value of current on phase A	hour: 00~24 minute: 00~60	byte	hour minute	2	R
229		second: 00~60	byte	second	1	R

22A	Maximum value of current on phase B	0.000 ~ 99999.999	Float	A	4	R
22B						
22C	Date for maximum value of current on phase B	year: 00~99 month: 1~12	byte	year month	2	R
22D		day: 1~31	byte	day	1	R
22E	Time for maximum value of current on phase B	hour: 00~24 minute: 00~60	byte	hour minute	2	R
22F		second: 00~60	byte	second	1	R
230	Maximum value of current on phase C	0.000 ~ 99999.999	Float	A	4	R
231						
232	Date for maximum value of current on phase C	year: 00~99 month: 1~12	byte	year month	2	R
233		day: 1~31	byte	day	1	R
234	Time for maximum value of current on phase C	hour: 00~24 minute: 00~60	byte	hour minute	2	R
235		second: 00~60	byte	second	1	R
236	Maximum value of natural current	0.000 ~ 99999.999	Float	A	4	R
237						
238	Date for maximum value of natural current	year: 00~99 month: 1~12	byte	year month	2	R
239		day: 1~31	byte	day	1	R
23A	Time for maximum value of natural current	hour: 00~24 minute: 00~60	byte	hour minute	2	R
23B		second: 00~60	byte	second	1	R
23C	Maximum value of frequency	0.00000 ~ 1.00000	Float	Hz	4	R
23D						
23E	Date for maximum value of frequency	year: 00~99 month: 1~12	byte	year month	2	R
23F		day: 1~31	byte	day	1	R
240	Time for maximum value of frequency	hour: 00~24 minute: 00~60	byte	hour minute	2	R
241		second: 00~60	byte	second	1	R
242	Maximum value of total active power factor	0.000 ~ 99999.999	Float		4	R
243						
244	Date for maximum value of total active power factor	year: 00~99 month: 1~12	byte	year month	2	R
245		day: 1~31	byte	day	1	R
246	Time for maximum value of total active power factor	hour: 00~24 minute: 00~60	byte	hour minute	2	R
247		second: 00~60	byte	second	1	R
248	Maximum value of total active power	0.000 ~ 99999.999	Float	kW	4	R
249						
24A	Date for maximum value of total active power	year: 00~99 month: 1~12	byte	year month	2	R
24B		day: 1~31	byte	day	1	R

24C	Time for maximum value of total active power	hour: 00~24 minute: 00~60	byte	hour minute	2	R
24D		second: 00~60	byte	second	1	R
24E	Maximum value of total reactive power	0.000 ~ 99999.999	Float	kVAR	4	R
24F						
250	Date for maximum value of total reactive power	year: 00~99 month: 1~12	byte	year month	2	R
251		day: 1~31	byte	day	1	R
252	Time for maximum value of total reactive power	hour: 00~24 minute: 00~60	byte	hour minute	2	R
253		second: 00~60	byte	second	1	R
254	Maximum value of total apparent power	0.000 ~ 99999.999	Float	kVA	4	R
255						
256	Date for maximum value of total apparent power	year: 00~99 month: 1~12	byte	year month	2	R
257		day: 1~31	byte	day	1	R
258	Time for maximum value of total apparent power	hour: 00~24 minute: 00~60	byte	hour minute	2	R
259		second: 00~60	byte	second	1	R
25A	Maximum value of total harmonic distortion for voltage on line AB	0.00 ~ 99.99	Float	%	4	R
25B						
25C	Date for maximum value of total harmonic distortion for voltage on line AB	year: 00~99 month: 1~12	byte	year month	2	R
25D		day: 1~31	byte	day	1	R
25E	Time for maximum value of total harmonic distortion for voltage on line AB	hour: 00~24 minute: 00~60	byte	hour minute	2	R
25F		second: 00~60	byte	second	1	R
260	Maximum value of total harmonic distortion for voltage on line BC	0.00 ~ 99.99	Float	%	4	R
261						
262	Date for maximum value of total harmonic distortion for voltage on line BC	year: 00~99 month: 1~12	byte	year month	2	R
263		day: 1~31	byte	day	1	R
264	Time for maximum value of total harmonic distortion for voltage on line BC	hour: 00~24 minute: 00~60	byte	hour minute	2	R
265		second: 00~60	byte	second	1	R
266	Maximum value of total harmonic distortion for voltage on line CA	0.00 ~ 99.99	Float	%	4	R
267						
268	Date for maximum value of total harmonic distortion for voltage on line CA	year: 00~99 month: 1~12	byte	year month	2	R
269		day: 1~31	byte	day	1	R
26A	Time for maximum value of total harmonic distortion for voltage on line CA	hour: 00~24 minute: 00~60	byte	hour minute	2	R
26B		second: 00~60	byte	second	1	R
26C	Maximum value of total harmonic distortion for voltage on phase A	0.00 ~ 99.99	Float	%	4	R
26D						

26E	Date for maximum value of total harmonic distortion for voltage on phase A	year: 00~99 month: 1~12	byte	year month	2	R
26F		day: 1~31	byte	day	1	R
270	Time for maximum value of total harmonic distortion for voltage on phase A	hour: 00~24 minute: 00~60	byte	hour minute	2	R
271		second: 00~60	byte	second	1	R
272	Maximum value of total harmonic distortion for voltage on phase B	0.00 ~ 99.99	Float	%	4	R
273						
274	Date for maximum value of total harmonic distortion for voltage on phase B	year: 00~99 month: 1~12	byte	year month	2	R
275		day: 1~31	byte	day	1	R
276	Time for maximum value of total harmonic distortion for voltage on phase B	hour: 00~24 minute: 00~60	byte	hour minute	2	R
277		second: 00~60	byte	second	1	R
278	Maximum value of total harmonic distortion for voltage on phase C	0.00 ~ 99.99	Float	%	4	R
279						
27A	Date for maximum value of total harmonic distortion for voltage on phase C	year: 00~99, month: 1~12	byte	year month	2	R
27B		day: 1~31	byte	day	1	R
27C	Time for maximum value of total harmonic distortion for voltage on phase C	hour: 00~24 minute: 00~60	byte	hour minute	2	R
27D		second: 00~60	byte	second	1	R
27E	Maximum value of total harmonic distortion for line-voltage	0.00 ~ 99.99	Float	%	4	R
27F						
280	Date for maximum value of total harmonic distortion for line-voltage	year: 00~99 month: 1~12	byte	year month	2	R
281		day: 1~31	byte	day	1	R
282	Time for maximum value of total harmonic distortion for line-voltage	hour: 00~24 minute: 00~60	byte	hour minute	2	R
283		second: 00~60	byte	second	1	R
284	Maximum value of total harmonic distortion for phase-voltage	0.00 ~ 99.99	Float	%	4	R
285						
286	Date for maximum value of total harmonic distortion for phase-voltage	year: 00~99 month: 1~12	byte	year month	2	R
287		day: 1~31	byte	day	1	R
288	Time for maximum value of total harmonic distortion for phase-voltage	hour: 00~24 minute: 00~60	byte	hour minute	2	R
289		second: 00~60	byte	second	1	R
28A	Maximum value of total harmonic distortion for current on phase A	0.00 ~ 99.99	Float	%	4	R
28B						
28C	Date for maximum value of total harmonic distortion for current on phase A	year: 00~99 month: 1~12	byte	year month	2	R
28D		day: 1~31	byte	day	1	R
28E	Time for maximum value of total harmonic distortion for current on phase A	hour: 00~24 minute: 00~60	byte	hour minute	2	R
28F		second: 00~60	byte	second	1	R



290	Maximum value of total harmonic distortion for current on phase B	0.00 ~ 99.99	Float	%	4	R
291						
292	Date for maximum value of total harmonic distortion for current on phase B	year: 00~99 month: 1~12	byte	year month	2	R
293		day: 1~31	byte	day	1	R
294	Time for maximum value of total harmonic distortion for current on phase B	hour: 00~24 minute: 00~60	byte	hour minute	2	R
295		second: 00~60	byte	second	1	R
296	Maximum value of total harmonic distortion for current on phase C	0.00 ~ 99.99	Float	%	4	R
297						
298	Date for maximum value of total harmonic distortion for current on phase C	year: 00~99 month: 1~12	byte	year month	2	R
299		day: 1~31	byte	day	1	R
29A	Time for maximum value of total harmonic distortion for current on phase C	hour: 00~24 minute: 00~60	byte	hour minute	2	R
29B		second: 00~60	byte	second	1	R
29C	Maximum value of total harmonic distortion on current	0.00 ~ 99.99	Float	%	4	R
29D						
29E	Date for maximum value of total harmonic distortion on current	year: 00~99 month: 1~12	byte	year month	2	R
29F		day: 1~31	byte	day	1	R
2A0	Time for maximum value of total harmonic distortion on current	hour: 00~24 minute: 00~60	byte	hour minute	2	R
2A1		second: 00~60	byte	second	1	R
2A2	Maximum value of voltage unbalance on line AB	0.00 ~ 99.99	Float	%	4	R
2A3						
2A4	Date for maximum value of voltage unbalance on line AB	year: 00~99 month: 1~12	byte	year month	2	R
2A5		day: 1~31	byte	day	1	R
2A6	Time for maximum value of voltage unbalance on line AB	hour: 00~24 minute: 00~60	byte	hour minute	2	R
2A7		second: 00~60	byte	second	1	R
2A8	Maximum value of voltage unbalance on line BC	0.00 ~ 99.99	Float	%	4	R
2A9						
2AA	Date for maximum value of voltage unbalance on line BC	year: 00~99 month: 1~12	byte	year month	2	R
2AB		day: 1~31	byte	day	1	R
2AC	Time for maximum value of voltage unbalance on line BC	hour: 00~24 minute: 00~60	byte	hour minute	2	R
2AD		second: 00~60	byte	second	1	R
2AE	Maximum value of voltage unbalance on line CA	0.00 ~ 99.99	Float	%	4	R
2AF						
2B0	Date for maximum value of voltage unbalance on line CA	year: 00~99 month: 1~12	byte	year month	2	R
2B1		day: 1~31	byte	day	1	R

2B2	Time for maximum value of voltage unbalance on line CA	hour: 00~24 minute: 00~60	byte	hour minute	2	R
2B3		second: 00~60	byte	second	1	R
2B4	Maximum value of voltage unbalance on phase A	0.00 ~ 99.99	Float	%	4	R
2B5						
2B6	Date for maximum value of voltage unbalance on phase A	year: 00~99 month: 1~12	byte	year month	2	R
2B7		day: 1~31	byte	day	1	R
2B8	Time for maximum value of voltage unbalance on phase A	hour: 00~24 minute: 00~60	byte	hour minute	2	R
2B9		second: 00~60	byte	second	1	R
2BA	Maximum value of voltage unbalance on phase B	0.00 ~ 99.99	Float	%	4	R
2BB						
2BC	Date for maximum value of voltage unbalance on phase B	year: 00~99 month: 1~12	byte	year month	2	R
2BD		day: 1~31	byte	day	1	R
2BE	Time for maximum value of voltage unbalance on phase B	hour: 00~24 minute: 00~60	byte	hour minute	2	R
2BF		second: 00~60	byte	second	1	R
2C0	Maximum value of voltage unbalance on phase C	0.00 ~ 99.99	Float	%	4	R
2C1						
2C2	Date for maximum value of voltage unbalance on phase C	year: 00~99 month: 1~12	byte	year month	2	R
2C3		day: 1~31	byte	day	1	R
2C4	Time for maximum value of voltage unbalance on phase C	hour: 00~24 minute: 00~60	byte	hour minute	2	R
2C5		second: 00~60	byte	second	1	R
2C6	Maximum value of line-voltage unbalance	0.00 ~ 99.99	Float	%	4	R
2C7						
2C8	Date for maximum value of line-voltage unbalance	year: 00~99 month: 1~12	byte	year month	2	R
2C9		day: 1~31	byte	day	1	R
2CA	Time for maximum value of line-voltage unbalance	hour: 00~24 minute: 00~60	byte	hour minute	2	R
2CB		second: 00~60	byte	second	1	R
2CC	Maximum value of phase-voltage unbalance	0.00 ~ 99.99	Float	%	4	R
2CD						
2CE	Date for maximum value of phase-voltage unbalance	year: 00~99 month: 1~12	byte	year month	2	R
2CF		day: 1~31	byte	day	1	R
2D0	Time for maximum value of phase-voltage unbalance	hour: 00~24 minute: 00~60	byte	hour minute	2	R
2D1		second: 00~60	byte	second	1	R
2D2	Maximum value of current unbalance on phase A	0.00 ~ 99.99	Float	%	4	R
2D3						

2D4	Date for maximum value of current unbalance on phase A	year: 00~99 month: 1~12	byte	year month	2	R
2D5		day: 1~31	byte	day	1	R
2D6	Time for maximum value of current unbalance on phase A	hour: 00~24 minute: 00~60	byte	hour minute	2	R
2D7		second: 00~60	byte	second	1	R
2D8	Maximum value of current unbalance on phase B	0.00 ~ 99.99	Float	%	4	R
2D9						
2DA	Date for maximum value of current unbalance on phase B	year: 00~99 month: 1~12	byte	year month	2	R
2DB		day: 1~31	byte	day	1	R
2DC	Time for maximum value of current unbalance on phase B	hour: 00~24 minute: 00~60	byte	hour minute	2	R
2DD		second: 00~60	byte	second	1	R
2DE	Maximum value of current unbalance on phase C	0.00 ~ 99.99	Float	%	4	R
2DF						
2E0	Date for maximum value of current unbalance on phase C	year: 00~99 month: 1~12	byte	year month	2	R
2E1		day: 1~31	byte	day	1	R
2E2	Time for maximum value of current unbalance on phase C	hour: 00~24 minute: 00~60	byte	hour minute	2	R
2E3		second: 00~60	byte	second	1	R
2E4	Maximum value of phase-current unbalance	0.00 ~ 99.99	Float	%	2	R
2E5						
2E6	Date for maximum value of phase-current unbalance	year: 00~99 month: 1~12	byte	year month	2	R
2E7		day: 1~31	byte	day	1	R
2E8	Time for maximum value of phase-current unbalance	hour: 00~24 minute: 00~60	byte	hour minute	2	R
2E9		second: 00~60	byte	second	1	R

### 3. Minimum Value: 0300 - 03FF

300	Minimum value of voltage on line AB	0.000 ~ 99999.999	Float	V	4	R
301						
302	Date for minimum value of voltage on line AB	year: 00~99 month: 1~12	byte	year month	2	R
303		day: 1~31	byte	day	1	R
304	Time for minimum value of voltage on line AB	hour: 00~24 minute: 00~60	byte	hour minute	2	R
305		second: 00~60	byte	second	1	R
306	Minimum value of voltage on line BC	0.000 ~ 99999.999	Float	V	4	R
307						
308	Date for minimum value of voltage on line BC	year: 00~99 month: 1~12	byte	year month	2	R
309		day: 1~31	byte	day	1	R

30A	Time for minimum value of voltage on line BC	hour: 00~24 minute: 00~60	byte	hour minute	2	R
30B		second: 00~60	byte	second	1	R
30C	Minimum value of voltage on line CA	0.000 ~ 99999.999	Float	V	4	R
30D						
30E	Date for minimum value of voltage on line CA	year: 00~99 month: 1~12	byte	year month	2	R
30F		day: 1~31	byte	day	1	R
310	Time for minimum value of voltage on line CA	hour: 00~24 minute: 00~60	byte	hour minute	2	R
311		second: 00~60	byte	second	1	R
312	Minimum value of voltage on phase A	0.000 ~ 99999.999	Float	V	4	R
313						
314	Date for minimum value of voltage on phase A	year: 00~99 month: 1~12	byte	year month	2	R
315		day: 1~31	byte	day	1	R
316	Time for minimum value of voltage on phase A	hour: 00~24 minute: 00~60	byte	hour minute	2	R
317		second: 00~60	byte	second	1	R
318	Minimum value of voltage on phase B	0.000 ~ 99999.999	Float	V	4	R
319						
31A	Date for minimum value of voltage on phase B	year: 00~99 month: 1~12	byte	year month	2	R
31B		day: 1~31	byte	day	1	R
31C	Time for minimum value of voltage on phase B	hour: 00~24 minute: 00~60	byte	hour minute	2	R
31D		second: 00~60	byte	second	1	R
31E	Minimum value of voltage on phase C	0.000 ~ 99999.999	Float	V	4	R
31F						
320	Date for minimum value of voltage on phase C	year: 00~99 month: 1~12	byte	year month	2	R
321		day: 1~31	byte	day	1	R
322	Time for minimum value of voltage on phase C	hour: 00~24 minute: 00~60	byte	hour minute	2	R
323		second: 00~60	byte	second	1	R
324	Minimum value of current on phase A	0.000 ~ 99999.999	Float	A	4	R
325						
326	Date for minimum value of current on phase A	year: 00~99 month: 1~12	byte	year month	2	R
327		day: 1~31	byte	day	1	R
328	Time for minimum value of current on phase A	hour: 00~24 minute: 00~60	byte	hour minute	2	R
329		second: 00~60	byte	second	1	R
32A	Minimum value of current on phase B	0.000 ~ 99999.999	Float	A	4	R
32B						

32C	Date for minimum value of current on phase B	year: 00~99 month: 1~12	byte	year month	2	R
32D		day: 1~31	byte	day	1	R
32E	Time for minimum value of current on phase B	hour: 00~24 minute: 00~60	byte	hour minute	2	R
32F		second: 00~60	byte	second	1	R
330	Minimum value of current on phase C	0.000 ~ 99999.999	Float	A	4	R
331						
332	Date for minimum value of current on phase C	year: 00~99 month: 1~12	byte	year month	2	R
333		day: 1~31	byte	day	1	R
334	Time for minimum value of current on phase C	hour: 00~24 minute: 00~60	byte	hour minute	2	R
335		second: 00~60	byte	second	1	R
336	Minimum value of natural current	0.000 ~ 99999.999	Float	A	4	R
337						
338	Date for minimum value of natural current	year: 00~99 month: 1~12	byte	year month	2	R
339		day: 1~31	byte	day	1	R
33A	Time for minimum value of natural current	hour: 00~24 minute: 00~60	byte	hour minute	2	R
33B		second: 00~60	byte	second	1	R
33C	Minimum value of frequency	0.000 ~ 99999.999	Float	Hz	4	R
33D						
33E	Date for minimum value of frequency	year: 00~99 month: 1~12	byte	year month	2	R
33F		day: 1~31	byte	day	1	R
340	Time for minimum value of frequency	hour: 00~24 minute: 00~60	byte	hour minute	2	R
341		second: 00~60	byte	second	1	R
342	Minimum value of total active power factor	0.00000~1.00000	Float		4	R
343						
344	Date for minimum value of total active power factor	year: 00~99 month: 1~12	byte	year month	2	R
345		day: 1~31	byte	day	1	R
346	Time for minimum value of total active power factor	hour: 00~24 minute: 00~60	byte	hour minute	2	R
347		second: 00~60	byte	second	1	R
348	Minimum value of total active power	0.000 ~ 99999.999	Float	kW	4	R
349						
34A	Date for minimum value of total active power	year: 00~99 month: 1~12	byte	year month	2	R
34B		day: 1~31	byte	day	1	R
34C	Time for minimum value of total active power	hour: 00~24 minute: 00~60	byte	hour minute	2	R
34D		second: 00~60	byte	second	1	R

34E	Minimum value of total reactive power	0.000 ~ 99999.999	Float	kVAR	4	R
34F						
350	Date for minimum value of total reactive power	year: 00~99 month: 1~12	byte	year month	2	R
351		day: 1~31	byte	day	1	R
352	Time for minimum value of total reactive power	hour: 00~24 minute: 00~60	byte	hour minute	2	R
353		second: 00~60	byte	second	1	R
354	Minimum value of total apparent power	0.000 ~ 99999.999	Float	kVA	4	R
355						
356	Date for minimum value of total apparent power	year: 00~99 month: 1~12	byte	year month	2	R
357		day: 1~31	byte	day	1	R
358	Time for minimum value of total apparent power	hour: 00~24 minute: 00~60	byte	hour minute	2	R
359		second: 00~60	byte	second	1	R
35A	Minimum value of total harmonic distortion for voltage on line AB	0.000~999.999	Float	%	4	R
35B						
35C	Date for minimum value of total harmonic distortion for voltage on line AB	year: 00~99 month: 1~12	byte	year month	2	R
35D		day: 1~31	byte	day	1	R
35E	Time for minimum value of total harmonic distortion for voltage on line AB	hour: 00~24 minute: 00~60	byte	hour minute	2	R
35F		second: 00~60	byte	second	1	R
360	Minimum value of total harmonic distortion for voltage on line BC	0.000~999.999	Float	%	4	R
361						
362	Date for minimum value of total harmonic distortion for voltage on line BC	year: 00~99 month: 1~12	byte	year month	2	R
363		day: 1~31	byte	day	1	R
364	Time for minimum value of total harmonic distortion for voltage on line BC	hour: 00~24 minute: 00~60	byte	hour minute	2	R
365		second: 00~60	byte	second	1	R
366	Minimum value of total harmonic distortion for voltage on line CA	0.000~999.999	Float	%	4	R
367						
368	Date for minimum value of total harmonic distortion for voltage on line CA	year: 00~99 month: 1~12	byte	year month	2	R
369		day: 1~31	byte	day	1	R
36A	Time for minimum value of total harmonic distortion for voltage on line CA	hour: 00~24 minute: 00~60	byte	hour minute	2	R
36B		second: 00~60	byte	second	1	R
36C	Minimum value of total harmonic distortion for voltage on phase A	0.000~999.999	Float	%	4	R
36D						
36E	Date for minimum value of total harmonic distortion for voltage on phase A	year: 00~99 month: 1~12	byte	year month	2	R
36F		day: 1~31	byte	day	1	R

370	Time for minimum value of total harmonic distortion for voltage on phase A	hour: 00~24 minute: 00~60	byte	hour minute	2	R
371		second: 00~60	byte	second	1	R
372	Minimum value of total harmonic distortion for voltage on phase B	0.000~999.999	Float	%	4	R
373						
374	Date for minimum value of total harmonic distortion for voltage on phase B	year: 00~99 month: 1~12	byte	year month	2	R
375		day: 1~31	byte	day	1	R
376	Time for minimum value of total harmonic distortion for voltage on phase B	hour: 00~24 minute: 00~60	byte	hour minute	2	R
377		second: 00~60	byte	second	1	R
378	Minimum value of total harmonic distortion for voltage on phase C	0.000~999.999	Float	%	4	R
379						
37A	Date for minimum value of total harmonic distortion for voltage on phase C	year: 00~99 month: 1~12	byte	year month	2	R
37B		day: 1~31	byte	day	1	R
37C	Time for minimum value of total harmonic distortion for voltage on phase C	hour: 00~24 minute: 00~60	byte	hour minute	2	R
37D		second: 00~60	byte	second	1	R
37E	Minimum value of total harmonic distortion for line-voltage	0.000~999.999	Float	%	4	R
37F						
380	Date for minimum value of total harmonic distortion for line-voltage	year: 00~99 month: 1~12	byte	year month	2	R
381		day: 1~31	byte	day	1	R
382	Time for minimum value of total harmonic distortion for line-voltage	hour: 00~24 minute: 00~60	byte	hour minute	2	R
383		second: 00~60	byte	second	1	R
384	Minimum value of total harmonic distortion for phase-voltage	0.000~999.999	Float	%	4	R
385						
386	Date for minimum value of total harmonic distortion for phase-voltage	year: 00~99 month: 1~12	byte	year month	2	R
387		day: 1~31	byte	day	1	R
388	Time for minimum value of total harmonic distortion for phase-voltage	hour: 00~24 minute: 00~60	byte	hour minute	2	R
389		second: 00~60	byte	second	1	R
38A	Minimum value of total harmonic distortion for current on phase A	0.000~999.999	Float	%	4	R
38B						
38C	Date for minimum value of total harmonic distortion for current on phase A	year: 00~99 month: 1~12	byte	year month	2	R
38D		day: 1~31	byte	day	1	R
38E	Time for minimum value of total harmonic distortion for current on phase A	hour: 00~24 minute: 00~60	byte	hour minute	2	R
38F		second: 00~60	byte	second	1	R
390	Minimum value of total harmonic distortion for current on phase B	0.000~999.999	Float	%	4	R
391						

392	Date for minimum value of total harmonic distortion for current on phase B	year: 00~99 month: 1~12	byte	year month	2	R
393		day: 1~31	byte	day	1	R
394	Time for minimum value of total harmonic distortion for current on phase B	hour: 00~24 minute: 00~60	byte	hour minute	2	R
395		second: 00~60	byte	second	1	R
396	Minimum value of total harmonic distortion for current on phase C	0.000~999.999	Float	%	4	R
397						
398	Date for minimum value of total harmonic distortion for current on phase C	year: 00~99 month: 1~12	byte	year month	2	R
399		day: 1~31	byte	day	1	R
39A	Time for minimum value of total harmonic distortion for current on phase C	hour: 00~24 minute: 00~60	byte	hour minute	2	R
39B		second: 00~60	byte	second	1	R
39C	Minimum value of total harmonic distortion on current	0.000~999.999	Float	%	4	R
39D						
39E	Date for minimum value of total harmonic distortion on current	year: 00~99 month: 1~12	byte	year month	2	R
39F		day: 1~31	byte	day	1	R
3A0	Time for minimum value of total harmonic distortion on current	hour: 00~24 minute: 00~60	byte	hour minute	2	R
3A1		second: 00~60	byte	second	1	R
3A2	Minimum value of voltage unbalance on line AB	0.00~99.99	Float	%	4	R
3A3						
3A4	Date for minimum value of voltage unbalance on line AB	year: 00~99 month: 1~12	byte	year month	2	R
3A5		day: 1~31	byte	day	1	R
3A6	Time for minimum value of voltage unbalance on line AB	hour: 00~24 minute: 00~60	byte	hour minute	2	R
3A7		second: 00~60	byte	second	1	R
3A8	Minimum value of voltage unbalance on line BC	0.00~99.99	Float	%	4	R
3A9						
3AA	Date for minimum value of voltage unbalance on line BC	year: 00~99 month: 1~12	byte	year month	2	R
3AB		day: 1~31	byte	day	1	R
3AC	Time for minimum value of voltage unbalance on line BC	hour: 00~24 minute: 00~60	byte	hour minute	2	R
3AD		second: 00~60	byte	second	1	R
3AE	Minimum value of voltage unbalance on line CA	0.00~99.99	Float	%	4	R
3AF						
3B0	Date for minimum value of voltage unbalance on line CA	year: 00~99 month: 1~12	byte	year month	2	R
3B1		day: 1~31	byte	day	1	R
3B2	Time for minimum value of voltage unbalance on line CA	hour: 00~24 minute: 00~60	byte	hour minute	2	R
3B3		second: 00~60	byte	second	1	R



3B4	Minimum value of voltage unbalance on phase A	0.00~99.99	Float	%	4	R
3B5						
3B6	Date for minimum value of voltage unbalance on phase A	year: 00~99 month: 1~12	byte	year month	2	R
3B7		day: 1~31	byte	day	1	R
3B8	Time for minimum value of voltage unbalance on phase A	hour: 00~24 minute: 00~60	byte	hour minute	2	R
3B9		second: 00~60	byte	second	1	R
3BA	Minimum value of voltage unbalance on phase B	0.00~99.99	Float	%	4	R
3BB						
3BC	Date for minimum value of voltage unbalance on phase B	year: 00~99 month: 1~12	byte	year month	2	R
3BD		day: 1~31	byte	day	1	R
3BE	Time for minimum value of voltage unbalance on phase B	hour: 00~24 minute: 00~60	byte	hour minute	2	R
3BF		second: 00~60	byte	second	1	R
3C0	Minimum value of voltage unbalance on phase C	0.00~99.99	Float	%	4	R
3C1						
3C2	Date for minimum value of voltage unbalance on phase C	year: 00~99 month: 1~12	byte	year month	2	R
3C3		day: 1~31	byte	day	1	R
3C4	Time for minimum value of voltage unbalance on phase C	hour: 00~24 minute: 00~60	byte	hour minute	2	R
3C5		second: 00~60	byte	second	1	R
3C6	Minimum value of line-voltage unbalance	0.00~99.99	Float	%	4	R
3C7						
3C8	Date for minimum value of line-voltage unbalance	year: 00~99 month: 1~12	byte	year month	2	R
3C9		day: 1~31	byte	day	1	R
3CA	Time for minimum value of line-voltage unbalance	hour: 00~24 minute: 00~60	byte	hour minute	2	R
3CB		second: 00~60	byte	second	1	R
3CC	Minimum value of phase-voltage unbalance	0.00~99.99	Float	%	4	R
3CD						
3CE	Date for minimum value of phase-voltage unbalance	year: 00~99 month: 1~12	byte	year month	2	R
3CF		day: 1~31	byte	day	1	R
3D0	Time for minimum value of phase-voltage unbalance	hour: 00~24 minute: 00~60	byte	hour minute	2	R
3D1		second: 00~60	byte	second	1	R
3D2	Minimum value of current unbalance on phase A	0.00~99.99	Float	%	4	R
3D3						
3D4	Date for minimum value of current unbalance on phase A	year: 00~99 month: 1~12	byte	year month	2	R
3D5		day: 1~31	byte	day	1	R

3D6	Time for minimum value of current unbalance on phase A	hour: 00~24 minute: 00~60	byte	hour minute	2	R
3D7		second: 00~60	byte	second	1	R
3D8	Minimum value of current unbalance on phase B	0.00~99.99	Float	%	4	R
3D9						
3DA	Date for minimum value of current unbalance on phase B	year: 00~99 month: 1~12	byte	year month	2	R
3DB		day: 1~31	byte	day	1	R
3DC	Time for minimum value of current unbalance on phase B	hour: 00~24 minute: 00~60	byte	hour minute	2	R
3DD		second: 00~60	byte	second	1	R
3DE	Minimum value of current unbalance on phase C	0.00~99.99	Float	%	4	R
3DF						
3E0	Date for minimum value of current unbalance on phase C	year: 00~99 month: 1~12	byte	year month	2	R
3E1		day: 1~31	byte	day	1	R
3E2	Time for minimum value of current unbalance on phase C	hour: 00~24 minute: 00~60	byte	hour minute	2	R
3E3		second: 00~60	byte	second	1	R
3E4	Minimum value of phase-current unbalance	0.00~99.99	Float	%	2	R
3E5						
3E6	Date for minimum value of phase-current unbalance	year: 00~99 month: 1~12	byte	year month	2	R
3E7		day: 1~31	byte	day	1	R
3E8	Time for minimum value of phase-current unbalance	hour: 00~24 minute: 00~60	byte	hour minute	2	R
3E9		second: 00~60	byte	second	1	R

**4. Alarm: 0400 ~ 04FF**

400	alarm 01	00 ~ FF (high byte, category) 00 ~ FF (high byte, number of times)	1. over current 2. under current 3. over mid line voltage 4. over line voltage 5. under line voltage 6. over phase voltage 7. under phase voltage 8. over voltage unbalance 9. over current unbalance 10. over active power 11. over reactive power 12. over apparent power 13. active power factor (leading) 14. active power factor (lagging) 15. displacement power factor (leading) 16. displacement power factor (lagging) 17. required over current 18. required over apparent power 19. required over reactive power 20. required over apparent power 21. over voltage 22. under voltage 23. over voltage harmonic distortion 24. over current harmonic distortion 25. phase loss 26. reset meter 27. phase reverse 28. over DUI 29. over EUI	2	R
401	alarm 02	00 ~ FF (high byte, category) 00 ~ FF (high byte, number of times)		2	R
402	alarm 03	00 ~ FF (high byte, category) 00 ~ FF (high byte, number of times)		2	R
403	alarm 04	00 ~ FF (high byte, category) 00 ~ FF (high byte, number of times)		2	R
404	alarm 05	00 ~ FF (high byte, category) 00 ~ FF (high byte, number of times)		2	R
405	alarm 06	00 ~ FF (high byte, category) 00 ~ FF (high byte, number of times)		2	R
406	alarm 07	00 ~ FF (high byte, category) 00 ~ FF (high byte, number of times)		2	R
407	alarm 08	00 ~ FF (high byte, category) 00 ~ FF (high byte, number of times)		2	R
408	alarm 09	00 ~ FF (high byte, category) 00 ~ FF (high byte, number of times)		2	R
409	alarm 10	00 ~ FF (high byte, category) 00 ~ FF (high byte, number of times)		2	R
40A	alarm 11	00 ~ FF (high byte, category) 00 ~ FF (high byte, number of times)		2	R
40B	alarm 12	00 ~ FF (high byte, category) 00 ~ FF (high byte, number of times)		2	R
40C	alarm 13	00 ~ FF (high byte, category) 00 ~ FF (high byte, number of times)		2	R
40D	alarm 14	00 ~ FF (high byte, category) 00 ~ FF (high byte, number of times)		2	R
40E	alarm 15	00 ~ FF (high byte, category) 00 ~ FF (high byte, number of times)		2	R
40F	alarm 16	00 ~ FF (high byte, category) 00 ~ FF (high byte, number of times)		2	R
410	alarm 17	00 ~ FF (high byte, category) 00 ~ FF (high byte, number of times)		2	R
411	alarm 18	00 ~ FF (high byte, category) 00 ~ FF (high byte, number of times)		2	R
412	alarm 19	00 ~ FF (high byte, category) 00 ~ FF (high byte, number of times)		2	R
413	alarm 20	00 ~ FF (high byte, category) 00 ~ FF (high byte, number of times)		2	R
414	alarm 21	00 ~ FF (high byte, category) 00 ~ FF (high byte, number of times)		2	R
415	alarm 22	00 ~ FF (high byte, category) 00 ~ FF (high byte, number of times)		2	R
416	alarm 23	00 ~ FF (high byte, category) 00 ~ FF (high byte, number of times)		2	R
417	alarm 24	00 ~ FF (high byte, category) 00 ~ FF (high byte, number of times)		2	R

418	alarm 25	00 ~ FF (high byte, category) 00 ~ FF (high byte, number of times)	1. over current 2. under current		2	R
419	alarm 26	00 ~ FF (high byte, category) 00 ~ FF (high byte, number of times)	3. over mid line voltage 4. over line voltage		2	R
41A	alarm 27	00 ~ FF (high byte, category) 00 ~ FF (high byte, number of times)	5. under line voltage 6. over phase voltage		2	R
41B	alarm 28	00 ~ FF (high byte, category) 00 ~ FF (high byte, number of times)	7. under phase voltage 8. over voltage unbalance		2	R
41C	alarm 29	00 ~ FF (high byte, category) 00 ~ FF (high byte, number of times)	9. over current unbalance 10. over active power		2	R
41D	alarm 30	00 ~ FF (high byte, category) 00 ~ FF (high byte, number of times)	11. over reactive power 12. over apparent power		2	R
41E	alarm 31	00 ~ FF (high byte, category) 00 ~ FF (high byte, number of times)	13. active power factor (leading) 14. active power factor (lagging)		2	R
41F	alarm 32	00 ~ FF (high byte, category) 00 ~ FF (high byte, number of times)	15. displacement power factor (leading) 16. displacement power factor (lagging)		2	R
420	alarm 33	00 ~ FF (high byte, category) 00 ~ FF (high byte, number of times)	17. required over current 18. required over apparent power		2	R
421	alarm 34	00 ~ FF (high byte, category) 00 ~ FF (high byte, number of times)	19. required over reactive power 20. required over apparent power		2	R
422	alarm 35	00 ~ FF (high byte, category) 00 ~ FF (high byte, number of times)	21. over voltage 22. under voltage		2	R
423	alarm 36	00 ~ FF (high byte, category) 00 ~ FF (high byte, number of times)	23. over voltage harmonic distortion 24. over current harmonic distortion		2	R
424	alarm 37	00 ~ FF (high byte, category) 00 ~ FF (high byte, number of times)	25. phase loss 26. reset meter		2	R
425	alarm 38	00 ~ FF (high byte, category) 00 ~ FF (high byte, number of times)	27. phase reverse 28. over DUI		2	R
426	alarm 39	00 ~ FF (high byte, category) 00 ~ FF (high byte, number of times)	29. over EUI		2	R
427	alarm 40	00 ~ FF (high byte, category) 00 ~ FF (high byte, number of times)			2	R
428	alarm 01 date	year: 00~99 month: 1~12	byte	year month	2	R
429		day: 1~31	byte	day	1	R
42A	alarm 01 time	hour: 00~24 minute: 00~60	byte	hour minute	2	R
42B		second: 00~60	byte	second	1	R
42C	alarm 02 date	year: 00~99 month: 1~12	byte	year month	2	R
42D		day: 1~31	byte	day	1	R
42E	alarm 02 time	hour: 00~24 minute: 00~60	byte	hour minute	2	R
42F		second: 00~60	byte	second	1	R
430	alarm 03 date	year: 00~99 month: 1~12	byte	year month	2	R
431		day: 1~31	byte	day	1	R
432	alarm 03 time	hour: 00~24 minute: 00~60	byte	hour minute	2	R
433		second: 00~60	byte	second	1	R

434	alarm 04 date	year: 00~99 month: 1~12	byte	year month	2	R
435		day: 1~31	byte	day	1	R
436	alarm 04 time	hour: 00~24 minute: 00~60	byte	hour minute	2	R
437		second: 00~60	byte	second	1	R
438	alarm 05 date	year: 00~99 month: 1~12	byte	year month	2	R
439		day: 1~31	byte	day	1	R
43A	alarm 05 time	hour: 00~24 minute: 00~60	byte	hour minute	2	R
43B		second: 00~60	byte	second	1	R
43C	alarm 06 date	year: 00~99 month: 1~12	byte	year month	2	R
43D		day: 1~31	byte	day	1	R
43E	alarm 06 time	hour: 00~24 minute: 00~60	byte	hour minute	2	R
43F		second: 00~60	byte	second	1	R
440	alarm 07 date	year: 00~99 month: 1~12	byte	year month	2	R
441		day: 1~31	byte	day	1	R
442	alarm 07 time	hour: 00~24 minute: 00~60	byte	hour minute	2	R
443		second: 00~60	byte	second	1	R
444	alarm 08 date	year: 00~99 month: 1~12	byte	year month	2	R
445		day: 1~31	byte	day	1	R
446	alarm 08 time	hour: 00~24 minute: 00~60	byte	hour minute	2	R
447		second: 00~60	byte	second	1	R
448	alarm 09 date	year: 00~99 month: 1~12	byte	year month	2	R
449		day: 1~31	byte	day	1	R
44A	alarm 09 time	hour: 00~24 minute: 00~60	byte	hour minute	2	R
44B		second: 00~60	byte	second	1	R
44C	alarm 10 date	year: 00~99 month: 1~12	byte	year month	2	R
44D		day: 1~31	byte	day	1	R
44E	alarm 10 time	hour: 00~24 minute: 00~60	byte	hour minute	2	R
44F		second: 00~60	byte	second	1	R
450	alarm 11 date	year: 00~99 month: 1~12	byte	year month	2	R
451		day: 1~31	byte	day	1	R
452	alarm 11 time	hour: 00~24 minute: 00~60	byte	hour minute	2	R
453		second: 00~60	byte	second	1	R

454	alarm 12 date	year: 00~99 month: 1~12	byte	year month	2	R
455		day: 1~31	byte	day	1	R
456	alarm 12 time	hour: 00~24 minute: 00~60	byte	hour minute	2	R
457		second: 00~60	byte	second	1	R
458	alarm 13 date	year: 00~99 month: 1~12	byte	year month	2	R
459		day: 1~31	byte	day	1	R
45A	alarm 13 time	hour: 00~24 minute: 00~60	byte	hour minute	2	R
45B		second: 00~60	byte	second	1	R
45C	alarm 14 date	year: 00~99 month: 1~12	byte	year month	2	R
45D		day: 1~31	byte	day	1	R
45E	alarm 14 time	hour: 00~24 minute: 00~60	byte	hour minute	2	R
45F		second: 00~60	byte	second	1	R
460	alarm 15 date	year: 00~99 month: 1~12	byte	year month	2	R
461		day: 1~31	byte	day	1	R
462	alarm 15 time	hour: 00~24 minute: 00~60	byte	hour minute	2	R
463		second: 00~60	byte	second	1	R
464	alarm 16 date	year: 00~99 month: 1~12	byte	year month	2	R
465		day: 1~31	byte	day	1	R
466	alarm 16 time	hour: 00~24 minute: 00~60	byte	hour minute	2	R
467		second: 00~60	byte	second	1	R
468	alarm 17 date	year: 00~99 month: 1~12	byte	year month	2	R
469		day: 1~31	byte	day	1	R
46A	alarm 17 time	hour: 00~24 minute: 00~60	byte	hour minute	2	R
46B		second: 00~60	byte	second	1	R
46C	alarm 18 date	year: 00~99 month: 1~12	byte	year month	2	R
46D		day: 1~31	byte	day	1	R
46E	alarm 18 time	hour: 00~24 minute: 00~60	byte	hour minute	2	R
46F		second: 00~60	byte	second	1	R
470	alarm 19 date	year: 00~99 month: 1~12	byte	year month	2	R
471		day: 1~31	byte	day	1	R
472	alarm 19 time	hour: 00~24 minute: 00~60	byte	hour minute	2	R
473		second: 00~60	byte	second	1	R

474	alarm 20 date	year: 00~99 month: 1~12	byte	year month	2	R
475		day: 1~31	byte	day	1	R
476	alarm 20 time	hour: 00~24 minute: 00~60	byte	hour minute	2	R
477		second: 00~60	byte	second	1	R
478	alarm 21 date	year: 00~99 month: 1~12	byte	year month	2	R
479		day: 1~31	byte	day	1	R
47A	alarm 21 time	hour: 00~24 minute: 00~60	byte	hour minute	2	R
47B		second: 00~60	byte	second	1	R
47C	alarm 22 date	year: 00~99 month: 1~12	byte	year month	2	R
47D		day: 1~31	byte	day	1	R
47E	alarm 22 time	hour: 00~24 minute: 00~60	byte	hour minute	2	R
47F		second: 00~60	byte	second	1	R
480	alarm 23 date	year: 00~99 month: 1~12	byte	year month	2	R
481		day: 1~31	byte	day	1	R
482	alarm 23 time	hour: 00~24 minute: 00~60	byte	hour minute	2	R
483		second: 00~60	byte	second	1	R
484	alarm 24 date	year: 00~99 month: 1~12	byte	year month	2	R
485		day: 1~31	byte	day	1	R
486	alarm 24 time	hour: 00~24 minute: 00~60	byte	hour minute	2	R
487		second: 00~60	byte	second	1	R
488	alarm 25 date	year: 00~99 month: 1~12	byte	year month	2	R
489		day: 1~31	byte	day	1	R
48A	alarm 25 time	hour: 00~24 minute: 00~60	byte	hour minute	2	R
48B		second: 00~60	byte	second	1	R
48C	alarm 26 date	year: 00~99 month: 1~12	byte	year month	2	R
48D		day: 1~31	byte	day	1	R
48E	alarm 26 time	hour: 00~24 minute: 00~60	byte	hour minute	2	R
48F		second: 00~60	byte	second	1	R
490	alarm 27 date	year: 00~99 month: 1~12	byte	year month	2	R
491		day: 1~31	byte	day	1	R
492	alarm 27 time	hour: 00~24 minute: 00~60	byte	hour minute	2	R
493		second: 00~60	byte	second	1	R

494	alarm 28 date	year: 00~99 month: 1~12	byte	year month	2	R
495		day: 1~31	byte	day	1	R
496	alarm 28 time	hour: 00~24 minute: 00~60	byte	hour minute	2	R
497		second: 00~60	byte	second	1	R
498	alarm 29 date	year: 00~99 month: 1~12	byte	year month	2	R
499		day: 1~31	byte	day	1	R
49A	alarm 29 time	hour: 00~24 minute: 00~60	byte	hour minute	2	R
49B		second: 00~60	byte	second	1	R
49C	alarm 30 date	year: 00~99 month: 1~12	byte	year month	2	R
49D		day: 1~31	byte	day	1	R
49E	alarm 30 time	hour: 00~24 minute: 00~60	byte	hour minute	2	R
49F		second: 00~60	byte	second	1	R
4A0	alarm 31 date	year: 00~99 month: 1~12	byte	year month	2	R
4A1		day: 1~31	byte	day	1	R
4A2	alarm 31 time	hour: 00~24 minute: 00~60	byte	hour minute	2	R
4A3		second: 00~60	byte	second	1	R
4A4	alarm 32 date	year: 00~99 month: 1~12	byte	year month	2	R
4A5		day: 1~31	byte	day	1	R
4A6	alarm 32 time	hour: 00~24 minute: 00~60	byte	hour minute	2	R
4A7		second: 00~60	byte	second	1	R
4A8	alarm 33 date	year: 00~99 month: 1~12	byte	year month	2	R
4A9		day: 1~31	byte	day	1	R
4AA	alarm 33 time	hour: 00~24 minute: 00~60	byte	hour minute	2	R
4AB		second: 00~60	byte	second	1	R
4AC	alarm 34 date	year: 00~99 month: 1~12	byte	year month	2	R
4AD		day: 1~31	byte	day	1	R
4AE	alarm 34 time	hour: 00~24 minute: 00~60	byte	hour minute	2	R
4AF		second: 00~60	byte	second	1	R
4B0	alarm 35 date	year: 00~99 month: 1~12	byte	year month	2	R
4B1		day: 1~31	byte	day	1	R
4B2	alarm 35 time	hour: 00~24 minute: 00~60	byte	hour minute	2	R
4B3		second: 00~60	byte	second	1	R



4B4	alarm 36 date	year: 00~99 month: 1~12	byte	year month	2	R
4B5		day: 1~31	byte	day	1	R
4B6	alarm 36 time	hour: 00~24 minute: 00~60	byte	hour minute	2	R
4B7		second: 00~60	byte	second	1	R
4B8	alarm 37 date	year: 00~99 month: 1~12	byte	year month	2	R
4B9		day: 1~31	byte	day	1	R
4BA	alarm 37 time	hour: 00~24 minute: 00~60	byte	hour minute	2	R
4BB		second: 00~60	byte	second	1	R
4BC	alarm 38 date	year: 00~99 month: 1~12	byte	year month	2	R
4BD		day: 1~31	byte	day	1	R
4BE	alarm 38 time	hour: 00~24 minute: 00~60	byte	hour minute	2	R
4BF		second: 00~60	byte	second	1	R
4C0	alarm 39 date	year: 00~99 month: 1~12	byte	year month	2	R
4C1		day: 1~31	byte	day	1	R
4C2	alarm 39 time	hour: 00~24 minute: 00~60	byte	hour minute	2	R
4C3		second: 00~60	byte	second	1	R
4C4	alarm 40 date	year: 00~99 month: 1~12	byte	year month	2	R
4C5		day: 1~31	byte	day	1	R
4C6	alarm 40 time	hour: 00~24 minute: 00~60	byte	hour minute	2	R
4C7		second: 00~60	byte	second	1	R

### 5. Advanced Settings: 0500 ~ 05FF

500	Floor area (square meter)	0~65536	byte		2	R / W
501	Interval of data storage	0: disable 1: 1 min 2: 5 mins 3: 10 mins 4: 30 mins 5: 60 mins			1	R / W
502	Auto recording 1, enable	0: Disable 1: Enable			1	R / W
503	Auto recording 1, starting date setting	year: 00~99 month: 1~12	byte	year month	2	R / W
504		day: 1~31	byte	day	1	R / W
505	Auto recording 1, ending date setting	year: 00~99 month: 1~12	byte	year month	2	R / W
506		day: 1~31	byte	day	1	R / W
507	Auto recording 2, enable	0: Disable 1: Enable			1	R / W
508	Auto recording 2, starting date setting	year: 00~99 month: 1~12	byte	year month	2	R / W
509		day: 1~31	byte	day	1	R / W

50A	Auto recording 2, ending date setting	year: 00~99 month: 1~12	byte	year month	2	R / W
50B		day: 1~31	byte	day	1	R / W
50C	Block transfer 1 setting	0x0100~0x01C7	Int		2	R / W
50D	Block transfer 2 setting	0x0100~0x01C7	Int		2	R / W
...	....	0x0100~0x01C7	Int		2	R / W
551	Block transfer 70 setting	0x0100~0x01C7	Int		2	R / W
552	date for reset energy	year : 00~99 month : 1~12	byte	year month	2	R
553	date for reset energy	date : 1~31	byte	day	1	R
554	time for reset energy	hour : 00~24 minute : 00~60	byte	hour minute	2	R
555	time for reset energy	second : 00~60	byte	second	1	R
<b>Block transfer: 0600~06FF</b>						
600	Read block transfer 1				2	R
601	Read block transfer 2				2	R
⋮	....				2	R
645	Read block transfer 70				2	R
<b>Every level of harmonics: 0700~07FF</b>						
0700	Phase A voltage with 1 harmonic component	0.000~999.999	Float	%	4	R
	⋮	0.000~999.999	Float	%	4	R
0701	Phase A voltage with 11 harmonic component	0.000~999.999	Float	%	4	R
	⋮	0.000~999.999	Float	%	4	R
0702	Phase A voltage with 21 harmonic component	0.000~999.999	Float	%	4	R
	⋮	0.000~999.999	Float	%	4	R
	Phase A voltage with 31 harmonic component	0.000~999.999	Float	%	4	R
0703	Phase B voltage with 1 harmonic component	0.000~999.999	Float	%	4	R
	⋮	0.000~999.999	Float	%	4	R
0704	Phase B voltage with 11 harmonic component	0.000~999.999	Float	%	4	R
	⋮	0.000~999.999	Float	%	4	R
0705	Phase B voltage with 21 harmonic component	0.000~999.999	Float	%	4	R
	⋮	0.000~999.999	Float	%	4	R
	Phase B voltage with 31 harmonic component	0.000~999.999	Float	%	4	R
0706	Phase C voltage with 1 harmonic component	0.000~999.999	Float	%	4	R
	⋮	0.000~999.999	Float	%	4	R

0707	Phase C voltage with 11 harmonic component	0.000~999.999	Float	%	4	R
	⋮	0.000~999.999	Float	%	4	R
0708	Phase C voltage with 21 harmonic component	0.000~999.999	Float	%	4	R
	⋮	0.000~999.999	Float	%	4	R
	Phase C voltage with 31 harmonic component	0.000~999.999	Float	%	4	R
0709	Phase A current with 1 harmonic component	0.000~999.999	Float	%	4	R
	⋮	0.000~999.999	Float	%	4	R
070A	Phase A current with 11 harmonic component	0.000~999.999	Float	%	4	R
	⋮	0.000~999.999	Float	%	4	R
070B	Phase A current with 21 harmonic component	0.000~999.999	Float	%	4	R
	⋮	0.000~999.999	Float	%	4	R
	Phase A current with 31 harmonic component	0.000~999.999	Float	%	4	R
070C	Phase B current with 1 harmonic component	0.000~999.999	Float	%	4	R
	⋮	0.000~999.999	Float	%	4	R
070D	Phase B current with 11 harmonic component	0.000~999.999	Float	%	4	R
	⋮	0.000~999.999	Float	%	4	R
070E	Phase B current with 21 harmonic component	0.000~999.999	Float	%	4	R
	⋮	0.000~999.999	Float	%	4	R
	Phase B current with 31 harmonic component	0.000~999.999	Float	%	4	R
070F	Phase C current with 1 harmonic component	0.000~999.999	Float	%	4	R
	⋮	0.000~999.999	Float	%	4	R
0710	Phase C current with 11 harmonic component	0.000~999.999	Float	%	4	R
	⋮	0.000~999.999	Float	%	4	R
0711	Phase C current with 21 harmonic component	0.000~999.999	Float	%	4	R
	⋮	0.000~999.999	Float	%	4	R
	Phase C current with 31 harmonic component	0.000~999.999	Float	%	4	R

**the Data of a day: 0800 ~**

**Interval: 1 min**

**Data recording priority for each register**

year, month, date		byte		3	
Hour, minute, second		byte		3	
Phase voltage		Float		4	
Line voltage		Float		4	

Average current			Float		4	
Mid-line current			Float		4	
Power factor			Float		4	
Displacement power factor			Float		4	
Total active power			Float		4	
Total reactive power			Float		4	
Total apparent power			Float		4	
Positive direction active power			Uint		4	
Reversed direction active power			Uint		4	
Positive direction reactive power			Uint		4	
Reversed direction reactive power			Uint		4	
Positive direction apparent power			Uint		4	
Reversed direction apparent power			Uint		4	
0800	data log min 0 hour 0 day1				66	R
0801	data log min 1 hour 0 day1				66	R
0802	data log min 2 hour 0 day1				66	R
...	...				66	R
083B	data log min 59 hour 0 day1				66	R
083C	data log min 0 hour 1 day1				66	R
083D	data log min 1 hour 1 day1				66	R
083E	data log min 2 hour 1 day1				66	R
...	...				66	R
0877	data log min 59 hour 1 day1				66	R
0878	data log min 0 hour 2 day1				66	R
0879	data log min 1 hour 2 day1				66	R
087A	data log min 2 hour 2 day1				66	R
...	...				66	R
08B3	data log min 59 hour 2 day1				66	R
...	...				66	R
0D64	data log min 0 hour 23 day1				66	R
0D65	data log min 1 hour 23 day1				66	R
0D66	data log min 2 hour 23 day1				66	R
...	...				66	R
0D9F	data log min 59 hour 23 day1				66	R
0DA0	data log min 0 hour 0 day2				66	R
0DA1	data log min 1 hour 0 day2				66	R

0DA2	data log min 2 hour 0 day2				66	R
...	...				66	R
DDB	data log min 59 hour 0 day2				66	R
DDC	data log min 0 hour 1 day2				66	R
DDD	data log min 1 hour 1 day2				66	R
DDE	data log min 2 hour 1 day2				66	R
...	...				66	R
0E17	data log min 59 hour 1 day2				66	R
0E18	data log min 0 hour 2 day2				66	R
0E19	data log min 1 hour 2 day2				66	R
0E1A	data log min 2 hour 2 day2				66	R
...	...				66	R
0E53	data log min 59 hour 2 day2				66	R
...	...				66	R
1304	data log min 0 hour 23 day2				66	R
1305	data log min 1 hour 23 day2				66	R
1306	data log min 2 hour 23 day2				66	R
...	...				66	R
133F	data log min 59 hour 23 day2				66	R
...					66	66
AB20	data log min 0 hour 0 day30				66	R
AB21	data log min 1 hour 0 day30				66	R
AB22	data log min 2 hour 0 day30				66	R
...	...				66	R
AB5B	data log min 59 hour 0 day30				66	R
AB5C	data log min 0 hour 1 day30				66	R
AB5D	data log min 1 hour 1 day30				66	R
AB5E	data log min 2 hour 1 day30				66	R
...	...				66	R
AB96	data log min 59 hour 1 day30				66	R
AB97	data log min 0 hour 2 day30				66	R
AB98	data log min 1 hour 2 day30				66	R
AB99	data log min 2 hour 2 day30				66	R
...	...				66	R
ABD2	data log min 59 hour 2 day30				66	R
...	...				66	R

B084	data log min 0 hour 23 day30				66	R
B085	data log min 1 hour 23 day30				66	R
B086	data log min 2 hour 23 day30				66	R
...	...				66	R
B0BF	data log min 59 hour 23 day30				66	R
B0C0	data log min 0 hour 0 day31				66	R
B0C1	data log min 1 hour 0 day31				66	R
B0C2	data log min 2 hour 0 day31				66	R
...	...				66	R
B0FB	data log min 59 hour 0 day31				66	R
B0FC	data log min 0 hour 1 day31				66	R
B0FD	data log min 1 hour 1 day31				66	R
B0FE	data log min 2 hour 1 day31				66	R
...	...				66	R
B137	data log min 59 hour 1 day31				66	R
B138	data log min 0 hour 2 day31				66	R
B139	data log min 1 hour 2 day31				66	R
B13A	data log min 2 hour 2 day31				66	R
...	...				66	R
B173	data log min 59 hour 2 day31				66	R
...	...				66	R
B624	data log min 0 hour 23 day31				66	R
B625	data log min 1 hour 23 day31				66	R
B626	data log min 2 hour 23 day31				66	R
...	...				66	R
B65F	data log min 59 hour 23 day31				66	R
<b>Interval: 5 min</b>						
0800	data log min 0 hour 0 day1				66	R
0801	data log min 5 hour 0 day1				66	R
0802	data log min 10 hour 0 day1				66	R
...	...				66	R
080B	data log min 55 hour 0 day1				66	R
080C	data log min 0 hour 1 day1				66	R
080D	data log min 5 hour 1 day1				66	R
080E	data log min 10 hour 1 day1				66	R
...	...				66	R

0817	data log min 55 hour 1 day1				66	R
0818	data log min 0 hour 2 day1				66	R
0819	data log min 5 hour 2 day1				66	R
081A	data log min 10 hour 2 day1				66	R
...	...				66	R
0823	data log min 55 hour 2 day1				66	R
...	...				66	R
0914	data log min 0 hour 23 day1				66	R
0915	data log min 5 hour 23 day1				66	R
0916	data log min 10 hour 23 day1				66	R
...	...				66	R
091F	data log min 55 hour 23 day1				66	R
...					66	R
28A0	data log min 0 hour 0 day30				66	R
28A1	data log min 5 hour 0 day30				66	R
28A2	data log min 10 hour 0 day30				66	R
...	...				66	R
28AB	data log min 55 hour 0 day30				66	R
28AC	data log min 0 hour 1 day30				66	R
28AD	data log min 5 hour 1 day30				66	R
28AE	data log min 10 hour 1 day30				66	R
...	...				66	R
28B7	data log min 55 hour 1 day30				66	R
28B8	data log min 0 hour 2 day30				66	R
28B9	data log min 5 hour 2 day30				66	R
28BA	data log min 10 hour 2 day30				66	R
...	...				66	R
28C3	data log min 55 hour 2 day30				66	R
...	...				66	R
29B4	data log min 0 hour 23 day30				66	R
29B5	data log min 5 hour 23 day30				66	R
29B6	data log min 10 hour 23 day30				66	R
...	...				66	R
29BF	data log min 55 hour 23 day30				66	R
29C0	data log min 0 hour 0 day31				66	R
29C1	data log min 5 hour 0 day31				66	R

29C2	data log min 10 hour 0 day31				66	R
...	...				66	R
29CB	data log min 55 hour 0 day31				66	R
29CC	data log min 0 hour 1 day31				66	R
29CD	data log min 5 hour 1 day31				66	R
29CE	data log min 10 hour 1 day31				66	R
...	...				66	R
29D7	data log min 55 hour 1 day31				66	R
29D8	data log min 0 hour 2 day31				66	R
29D9	data log min 5 hour 2 day31				66	R
29DA	data log min 10 hour 2 day31				66	R
...	...				66	R
29E3	data log min 55 hour 2 day31				66	R
...	...				66	R
2AD4	data log min 0 hour 23 day31				66	R
2AD5	data log min 5 hour 23 day31				66	R
2AD6	data log min 10 hour 23 day31				66	R
...	...				66	R
2ADF	data log min 55 hour 23 day31				66	R
...	...				66	R
4A60	data log min 0 hour 0 day60				66	R
4A61	data log min 5 hour 0 day60				66	R
4A62	data log min 10 hour 0 day60				66	R
...	...				66	R
4A6B	data log min 55 hour 0 day60				66	R
4A6C	data log min 0 hour 1 day60				66	R
4A6D	data log min 5 hour 1 day60				66	R
4A6E	data log min 10 hour 1 day60				66	R
...	...				66	R
4A77	data log min 55 hour 1 day60				66	R
4A78	data log min 0 hour 2 day60				66	R
4A79	data log min 5 hour 2 day60				66	R
4A7A	data log min 10 hour 2 day60				66	R
...	...				66	R
4A83	data log min 55 hour 2 day60				66	R
...	...				66	R



4B74	data log min 0 hour 23 day60				66	R
4B75	data log min 5 hour 23 day60				66	R
4B76	data log min 10 hour 23 day60				66	R
...	...				66	R
4B7F	data log min 55 hour 23 day60				66	R
4B80	data log min 0 hour 0 day61				66	R
4B81	data log min 5 hour 0 day61				66	R
4B82	data log min 10 hour 0 day61				66	R
...	...				66	R
4B8B	data log min 55 hour 0 day61				66	R
4B8C	data log min 0 hour 1 day61				66	R
4B8D	data log min 5 hour 1 day61				66	R
4B8E	data log min 10 hour 1 day61				66	R
...	...				66	R
4B97	data log min 55 hour 1 day61				66	R
4B98	data log min 0 hour 2 day61				66	R
4B99	data log min 5 hour 2 day61				66	R
4B9A	data log min 10 hour 2 day61				66	R
...	...				66	R
4BA3	data log min 55 hour 2 day61				66	R
...	...				66	R
4C94	data log min 0 hour 23 day61				66	R
4C95	data log min 5 hour 23 day61				66	R
4C96	data log min 10 hour 23 day61				66	R
...	...				66	R
4C9F	data log min 55 hour 23 day61				66	R
4CA0	data log min 0 hour 0 day62				66	R
4CA1	data log min 5 hour 0 day62				66	R
4CA2	data log min 10 hour 0 day62				66	R
...	...				66	R
4CAB	data log min 55 hour 0 day62				66	R
4CAC	data log min 0 hour 1 day62				66	R
4CAD	data log min 5 hour 1 day62				66	R
4CAE	data log min 10 hour 1 day62				66	R
...	...				66	R
4CB7	data log min 55 hour 1 day62				66	R

4CB8	data log min 0 hour 2 day62				66	R
4CB9	data log min 5 hour 2 day62				66	R
4CBA	data log min 10 hour 2 day62				66	R
...	...				66	R
4CC3	data log min 55 hour 2 day62				66	R
...	...				66	R
4DB4	data log min 0 hour 23 day62				66	R
4DB5	data log min 5 hour 23 day62				66	R
4DB6	data log min 10 hour 23 day62				66	R
...	...				66	R
4DBF	data log min 55 hour 23 day62				66	R
<b>Interval: 10 min</b>						
0800	data log min 0 hour 0 day1				66	R
0801	data log min 10 hour 0 day1				66	R
0802	data log min 20 hour 0 day1				66	R
...	...				66	R
0805	data log min 50 hour 0 day1				66	R
0806	data log min 0 hour 1 day1				66	R
0807	data log min 10 hour 1 day1				66	R
0808	data log min 20 hour 1 day1				66	R
...	...				66	R
080B	data log min 50 hour 1 day1				66	R
080C	data log min 0 hour 2 day1				66	R
080D	data log min 10 hour 2 day1				66	R
080E	data log min 20 hour 2 day1				66	R
...	...				66	R
0811	data log min 50 hour 2 day1				66	R
...	...				66	R
088A	data log min 0 hour 23 day1				66	R
088B	data log min 10 hour 23 day1				66	R
088C	data log min 20 hour 23 day1				66	R
...	...				66	R
088F	data log min 50 hour 23 day1				66	R
...	...				66	R
1850	data log min 0 hour 0 day30				66	R
1851	data log min 10 hour 0 day30				66	R
1852	data log min 20 hour 0 day30				66	R

...	...				66	R
1855	data log min 50 hour 0 day30				66	R
1856	data log min 0 hour 1 day30				66	R
1857	data log min 10 hour 1 day30				66	R
1858	data log min 20 hour 1 day30				66	R
...	...				66	R
185B	data log min 50 hour 1 day30				66	R
185C	data log min 0 hour 2 day30				66	R
185D	data log min 10 hour 2 day30				66	R
185E	data log min 20 hour 2 day30				66	R
...	...				66	R
1861	data log min 50 hour 2 day30				66	R
...	...				66	R
18DA	data log min 0 hour 23 day30				66	R
18DB	data log min 10 hour 23 day30				66	R
18DC	data log min 20 hour 23 day30				66	R
...	...				66	R
18DF	data log min 50 hour 23 day30				66	R
18E0	data log min 0 hour 0 day31				66	R
18E1	data log min 10 hour 0 day31				66	R
18E2	data log min 20 hour 0 day31				66	R
...	...				66	R
18E5	data log min 50 hour 0 day31				66	R
18E6	data log min 0 hour 1 day31				66	R
18E7	data log min 10 hour 1 day31				66	R
18E8	data log min 20 hour 1 day31				66	R
...	...				66	R
18EB	data log min 50 hour 1 day31				66	R
18EC	data log min 0 hour 2 day31				66	R
18ED	data log min 10 hour 2 day31				66	R
18EE	data log min 20 hour 2 day31				66	R
...	...				66	R
18F1	data log min 50 hour 2 day31				66	R
...	...				66	R
196A	data log min 0 hour 23 day31				66	R
196B	data log min 10 hour 23 day31				66	R
196C	data log min 20 hour 23 day31				66	R

...	...				66	R
196F	data log min 50 hour 23 day31				66	R
...	...				66	R
2930	data log min 0 hour 0 day60				66	R
2931	data log min 10 hour 0 day60				66	R
2932	data log min 20 hour 0 day60				66	R
...	...				66	R
2935	data log min 50 hour 0 day60				66	R
2936	data log min 0 hour 1 day60				66	R
2937	data log min 10 hour 1 day60				66	R
2938	data log min 20 hour 1 day60				66	R
...	...				66	R
293B	data log min 50 hour 1 day60				66	R
293C	data log min 0 hour 2 day60				66	R
293D	data log min 10 hour 2 day60				66	R
293E	data log min 20 hour 2 day60				66	R
...	...				66	R
2941	data log min 50 hour 2 day60				66	R
...	...				66	R
29BA	data log min 0 hour 23 day60				66	R
29BB	data log min 10 hour 23 day60				66	R
29BC	data log min 20 hour 23 day60				66	R
...	...				66	R
29BF	data log min 50 hour 23 day60				66	R
29C0	data log min 0 hour 0 day61				66	R
29C1	data log min 10 hour 0 day61				66	R
29C2	data log min 20 hour 0 day61				66	R
...	...				66	R
29C5	data log min 50 hour 0 day61				66	R
29C6	data log min 0 hour 1 day61				66	R
29C7	data log min 10 hour 1 day61				66	R
29C8	data log min 20 hour 1 day61				66	R
...	...				66	R
29CB	data log min 50 hour 1 day61				66	R
29CC	data log min 0 hour 2 day61				66	R
29CD	data log min 10 hour 2 day61				66	R
29CE	data log min 20 hour 2 day61				66	R

...	...				66	R
29D1	data log min 50 hour 2 day61				66	R
...	...				66	R
2A4A	data log min 0 hour 23 day61				66	R
2A4B	data log min 10 hour 23 day61				66	R
2A4C	data log min 20 hour 23 day61				66	R
...	...				66	R
2A4F	data log min 50 hour 23 day61				66	R
2A50	data log min 0 hour 0 day62				66	R
2A51	data log min 10 hour 0 day62				66	R
2A52	data log min 20 hour 0 day62				66	R
...	...				66	R
2A55	data log min 50 hour 0 day62				66	R
2A56	data log min 0 hour 1 day62				66	R
2A57	data log min 10 hour 1 day62				66	R
2A58	data log min 20 hour 1 day62				66	R
...	...				66	R
2A5B	data log min 50 hour 1 day62				66	R
2A5C	data log min 0 hour 2 day62				66	R
2A5D	data log min 10 hour 2 day62				66	R
2A5E	data log min 20 hour 2 day62				66	R
...	...				66	R
2A61	data log min 50 hour 2 day62				66	R
...	...				66	R
2ADA	data log min 0 hour 23 day62				66	R
2ADB	data log min 10 hour 23 day62				66	R
2ADC	data log min 20 hour 23 day62				66	R
...	...				66	R
2ADF	data log min 50 hour 23 day62				66	R
<b>Interval: 30 min</b>						
0800	data log min 0 hour 0 day1				66	R
0801	data log min 30 hour 0 day1				66	R
0802	data log min 0 hour 1 day1				66	R
0803	data log min 30 hour 1 day1				66	R
0804	data log min 0 hour 2 day1				66	R
0805	data log min 30 hour 2 day1				66	R
...	...				66	R

082E	data log min 0 hour 23 day1				66	R
082F	data log min 30 hour 23 day1				66	R
...	...				66	R
0D70	data log min 0 hour 0 day30				66	R
0D71	data log min 30 hour 0 day30				66	R
0D72	data log min 0 hour 1 day30				66	R
0D73	data log min 30 hour 1 day30				66	R
0D74	data log min 0 hour 2 day30				66	R
0D75	data log min 30 hour 2 day30				66	R
...	...				66	R
0D9E	data log min 0 hour 23 day30				66	R
0D9F	data log min 30 hour 23 day30				66	R
0DA0	data log min 0 hour 0 day31				66	R
0DA1	data log min 30 hour 0 day31				66	R
0DA2	data log min 0 hour 1 day31				66	R
0DA3	data log min 30 hour 1 day31				66	R
0DA4	data log min 0 hour 2 day31				66	R
0DA5	data log min 30 hour 2 day31				66	R
...	...				66	R
0DCE	data log min 0 hour 23 day31				66	R
0DCF	data log min 30 hour 23 day31				66	R
...	...				66	R
1310	data log min 0 hour 0 day60				66	R
1311	data log min 30 hour 0 day60				66	R
1312	data log min 0 hour 1 day60				66	R
1313	data log min 30 hour 1 day60				66	R
1314	data log min 0 hour 2 day60				66	R
1315	data log min 30 hour 2 day60				66	R
...	...				66	R
133E	data log min 0 hour 23 day60				66	R
133F	data log min 30 hour 23 day60				66	R
1340	data log min 0 hour 0 day61				66	R
1341	data log min 30 hour 0 day61				66	R
1342	data log min 0 hour 1 day61				66	R
1343	data log min 30 hour 1 day61				66	R
1344	data log min 0 hour 2 day61				66	R

1345	data log min 30 hour 2 day61				66	R
...	...				66	R
136E	data log min 0 hour 23 day61				66	R
136F	data log min 30 hour 23 day61				66	R
1470	data log min 0 hour 0 day62				66	R
1471	data log min 30 hour 0 day62				66	R
1472	data log min 0 hour 1 day62				66	R
1473	data log min 30 hour 1 day62				66	R
1474	data log min 0 hour 2 day62				66	R
1475	data log min 30 hour 2 day62				66	R
...	...				66	R
149E	data log min 0 hour 23 day62				66	R
149F	data log min 30 hour 23 day62				66	R
<b>Interval: 60 min</b>						
0800	data log min 0 hour 0 day1				66	R
0801	data log min 0 hour 1 day1				66	R
0802	data log min 0 hour 2 day1				66	R
...	...				66	R
0817	data log min 0 hour 23 day1				66	R
...	...				66	R
0AB8	data log min 0 hour 0 day30				66	R
0AB9	data log min 30 hour 0 day30				66	R
0ABA	data log min 0 hour 1 day30				66	R
...	...				66	R
0ACF	data log min 30 hour 23 day30				66	R
0AD0	data log min 0 hour 0 day31				66	R
0AD1	data log min 0 hour 1 day31				66	R
0AD2	data log min 0 hour 2 day31				66	R
...	...				66	R
0AE7	data log min 0 hour 23 day31				66	R
...	...				66	R
0D88	data log min 0 hour 0 day60				66	R
0D89	data log min 30 hour 0 day60				66	R
0D8A	data log min 0 hour 1 day60				66	R
...	...				66	R
0D9F	data log min 30 hour 23 day60				66	R

0DA0	data log min 0 hour 0 day61				66	R
0DA1	data log min 30 hour 0 day61				66	R
0DA2	data log min 0 hour 1 day61				66	R
...	...				66	R
0DB7	data log min 30 hour 23 day61				66	R
0DB8	data log min 0 hour 0 day62				66	R
0DB9	data log min 30 hour 0 day62				66	R
0DBA	data log min 0 hour 1 day62				66	R
...	...				66	R
0DCF	data log min 30 hour 23 day62				66	R
<b>Alarm History</b>						
B700	Alarm History 1	00 ~ FF (high byte, category) 00 ~ FF (high byte, number of times)	byte		2	R
B701	Alarm History 2	00 ~ FF (high byte, category) 00 ~ FF (high byte, number of times)	byte		2	R
B702	Alarm History 3	00 ~ FF (high byte, category) 00 ~ FF (high byte, number of times)	byte		2	R
...	...	...				R
B8F3	Alarm History 500	00 ~ FF (high byte, category) 00 ~ FF (high byte, number of times)	byte		2	R
B8F4	alarm 01 date	year: 00~99 month: 1~12	byte	year month	2	R
B8F5		day: 1~31	byte	day	1	R
B8F6	alarm 01 time	hour: 00~24 minute: 00~60	byte	hour minute	2	R
B8F7		second: 00~60	byte	second	1	R
B8F8	alarm 02 date	year: 00~99 month: 1~12	byte	year month	2	R
B8F9		day: 1~31	byte	day	1	R
B8FA	alarm 02 time	hour: 00~24 minute: 00~60	byte	hour minute	2	R
B8FB		second: 00~60	byte	second	1	R
B8FC	alarm 03 date	year: 00~99 month: 1~12	byte	year month	2	R
B8FD		day: 1~31	byte	day	1	R
B8FE	alarm 03 time	hour: 00~24 minute: 00~60	byte	hour minute	2	R
B8FF		second: 00~60	byte	second	1	R
...	...	...				R
C0C0	alarm 500 date	year: 00~99 month: 1~12	byte	year month	2	R
C0C1		day: 1~31	byte	day	1	R
C0C2	alarm 500 time	hour: 00~24 minute: 00~60	byte	hour minute	2	R
C0C3		second: 00~60	byte	second	1	R



# Messages of Abnormal Operations

Under abnormal communications, the power meter can send out messages via Modbus (codes shown below), informing the reason why the main station experienced abnormal situation.

Abnormal Message Code	Name	Description
0x01	Illegal Function	Illegal functional code
0x02	Illegal Data Address	Address of data read or written is illegal
0x03	Illegal Data Value	Illegal data format (such as incorrect data length)
0x04	Slave Device Failure	Slave device fails to follow commands

Based on start/stop status for the 29 types of alarm settings (register location 0x3E~0xFF) under abnormal situations, the power meter records the type and time of the alarm occurred in the register location 0x0A01~0x0ACF. The types of alarms and their descriptions are as follows:

Alarm Number	Alarm Type	Description
1	Over-current	Average current is higher than alert value
2	Low current	Average current is lower than alert value
3	Over natural current	Natural current is higher than alert value
4	Over line voltage	Average line voltage is higher than alert value
5	Low line voltage	Average line voltage is lower than alert value
6	Over phase voltage	Average phase voltage is higher than alert value
7	Low phase voltage	Average phase voltage is lower than alert value
8	Over-voltage imbalance	Rate of voltage imbalance is higher than alert value
9	Over-current imbalance	Rate of current imbalance is lower than alert value
10	Over active power	Total active power is higher than alert value
11	Over reactive power	Total reactive power is higher than alert value
12	Over apparent power	Total apparent power is higher than alert value
13	Active power factor (leading)	Power factor under leading load is lower than alert value
14	Active power factor (lagging)	Power factor under lagging load is lower than alert value
15	Displacement power factor (leading)	Displacement power factor under leading load is lower than alert value
16	Displacement power factor (lagging)	Displacement power factor under lagging load is lower than alert value
17	Over current demand	Current demand is higher than alert value

18	Over active power demand	Total active power demand is higher than alert value
19	Over reactive power demand	Total reactive power demand is higher than alert value
20	Over apparent power demand	Total apparent power demand is higher than alert value
21	Over-frequency	System frequency is higher than alert value
22	Low frequency	System frequency is lower than alert value
23	Over-voltage in total harmonic distortion	Total harmonic distortion for voltage is higher than alert value
24	Over-current in total harmonic distortion	Total harmonic distortion for current is higher than alert value
25	Phase loss	When the system is unbalanced, voltage is lower than alert value.
26	Over-DUI	DUI value is higher than alert value
27	Over EUI	EUI value is higher than alert value
28	Meter reset	The power meter is resetting parameters.
29	Phase Sequence Reversal	Phase A and C for current are inversely connected

# Specifications

## 9.1 Specifications

Feature		
Model Name	DPM-C530A	
Measurement Parameters	Phase voltage	√
	Line voltage	√
	Phase current	√
	Line current	√
	Active power	√
	Reactive power	√
	Apparent power	√
	Power factor	√
	Frequency	√
Energy Parameters	Real energy	√
	Reactive energy	√
	Apparent energy	√
	Interval energy	√
Demand	Demand current	3-phase average demand current, 3-phase peak average demand current
	Demand power	3-phase average demand for active power/reactive / apparent power, 3-phase peak average demand for real/reactive/apparent power
	Demand calculation	Block
Max./min. Value	Max./min. value and time tag	Phase voltage, line voltage, current, frequency, total 3-phase active power, total 3-phase reactive power, total 3-phase apparent power, total power factor, total voltage harmonic distortion, phase voltage harmonic distortion, total current harmonic distortion, phase voltage unbalance, 3-phase voltage unbalance, 3-phase current unbalance
Power Quality	Phase voltage unbalance	Support
	Phase current unbalance	Support
	2nd ~31st harmonic voltage of each phase	Support
	2nd ~ 31st harmonic current of each phase	Support
	2nd ~ 31st total harmonic voltage of 3-phase	Support
	2nd ~ 31st total harmonic current of 3-phase	Support

Alarm	Off-limit alarm	29 types of off-limit alarms	
History log	Line voltage, phase voltage, current, power factor, active power, reactive power, apparent power, real energy, reactive energy, apparent energy		
Communication interface	RS-485	Modbus-RTU, Modbus-ASCII	
		Baud rate 9600/19200/38400bps	
Display	White light LCD / 198x160 dots		
<b>Electrical specifications</b>			
Accuracy	Quantity of Electricity	Voltage, Current	±0.2%
		Active power, reactive power, apparent power	±0.5%
	Electrical Energy	Active Power	±0.5%
		Reactive Power	±0.5%
	Power Factor		±0.5%
	Active power demand		±0.5%
	Reactive power demand		±0.5%
	Apparent power demand		±0.5%
	Total harmonics in current		±1%
	Total harmonics in voltage		±1%
	Harmonics		±1%
	Frequency Accuracy		±0.5%
	Input	Wiring Method	
Voltage		Rated Value	Line Voltage: 35~690V AC (L-L)
Current		Rated Value	Phase Voltage: 20~400V AC (L-N)
Frequency		1A/5A	
Alarm Output	Alarm parameters selectable		29 kinds of alarms selectable
	Output Method		DO Output
Power	Functional Range		80~265 VAC (max power dissipation 4.6 W)

Communication Interface	RS485 Interface	Modbus RTU / ASCII
		Baud Rate 9600/19200/38400 bps
Exterior	Dimensions (Width x Height x Depth)	96 x 96 x 95.4 mm
	IP Protections	IP52 (front panel), IP20 (meter body)
Environment	Operating Temperature	-20°C ~ +70°C
	Storage Temperature	-30°C ~ +80°C
	Relative Humidity	~95% RH
	Altitude	Below 2000 meters

## 9.2 Communication Specifications

Communication Specifications	
Max distance of communication	1200 m
Max number of connected stations	32
Communication Protocols	Modbus RTU / ASCII
Functional Code	03, 06
Baud Rate	9600, 19200, 38400
Data Bit	7, 8
Parity	None, Odd, Even
Stop Bit	1, 2

## 9.3 Modbus Communication

### 9.3.1 Format of Modbus Communication:

Function Code	Modbus Name	Description
0x03	Read Holding Registers	Read the contents of read location
0x06	Preset Single Register	Preset the contents of written location
0xFE	Read Data Log	Read the contents of data log

### 9.3.2 Modbus Communication Protocols

(1) Modbus RTU mode is adopted with Modbus Master sending out the Request, in which the Function Code uses 0x03 to request response from Slave to correspond to values in Modbus address. In Response, Modbus Slave responds to the values of Modbus address in the Master request. The packet format of IEEE754 is used for the address of floating point numbers that corresponds to the register values found in table 7.1, using 2's complement packet format. The format are as follows:

Low Word		High Word	
High Byte	Low Byte	High Byte	Low Byte

The packet formats for the address of integers that corresponds to the register values found in table 7.1 are shown in the example below.

#### Read out:

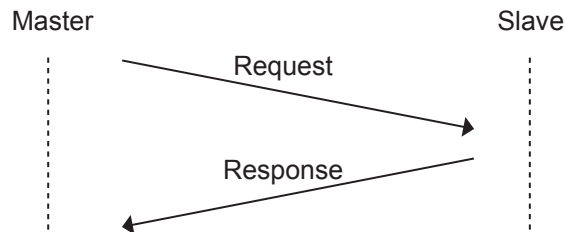

#### Request

Slave Address	1 ~ 255
Function Code	03h
Start Address (High)	00h ~ FFh
Start Address (Low)	00h ~ FFh
Number of Point (High)	00h
Number of Point (Low)	00h ~ FFh
Error Check (Low)	CRC
Error Check (High)	CRC

#### Response

Slave Address	1 ~ 255
Function Code	03h
Byte Count	00h ~ FFh
Data (High)	00h
Data (Low)	00h ~ FFh
Error Check (Low)	CRC
Error Check (High)	CRC

**Write in:**

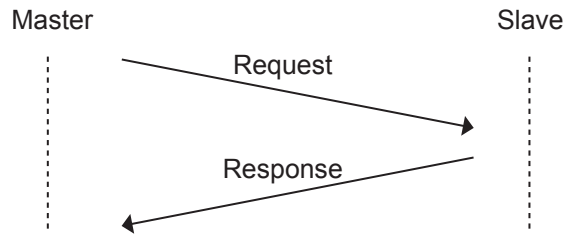

**Request**

Slave Address	1 ~ 255
Function Code	06h
Start Address (High)	00h ~ FFh
Start Address (Low)	00h ~ FFh
Number of Point (High)	00h
Number of Point (Low)	00h ~ FFh
Error Check (Low)	CRC
Error Check (High)	CRC

**Response**

Slave Address	1 ~ 255
Function Code	06h
Start Address (High)	00h ~ FFh
Start Address (Low)	00h ~ FFh
Number of Point (High)	00h
Number of Point (Low)	00h ~ FFh
Error Check (Low)	CRC
Error Check (High)	CRC

**Example:**

For Modbus Master, such as PLC or data collector, it uses Modbus communication protocol to get a reading for the value of currents from the primary current transformer (register address 0x000E) on the power meter (Modbus Slave) (Slave address 0x1). The register value is 1000.

The packet format for Request sent out by Modbus Master (PLC or data collector) is as follows:

**Master Request**

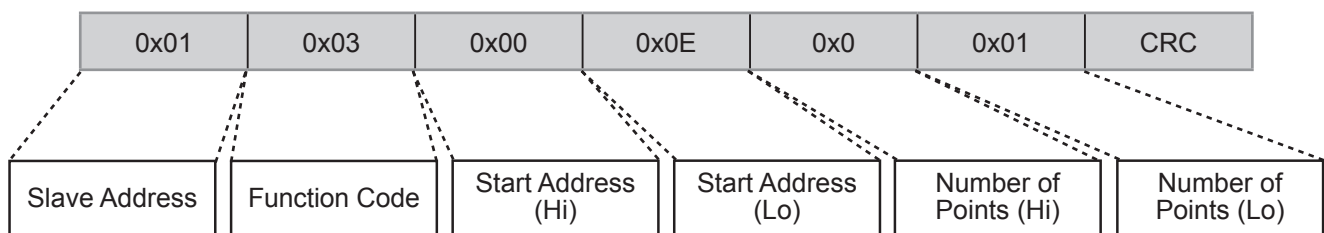

The packet format for Response responded by Modbus Slave (power meter) is as follows:

**Slave Response**

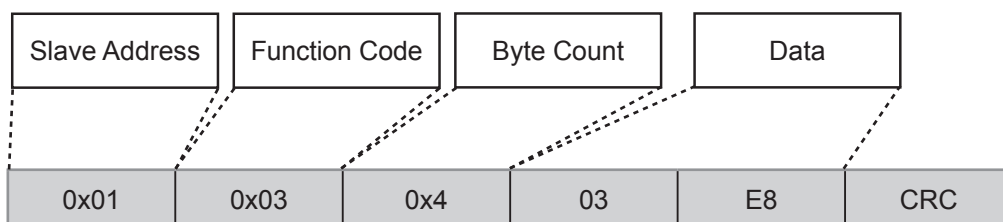

After receiving response from the power meter, Modbus Master acquires the value of currents from the primary-side current transformer (register address 0x000E), which is 1000.

Should Modbus Slave (power meter) receive an abnormal Request, the format of the abnormal packet responded is as follows. Refer to Chapter 9 for the abnormal codes.

### Slave Response

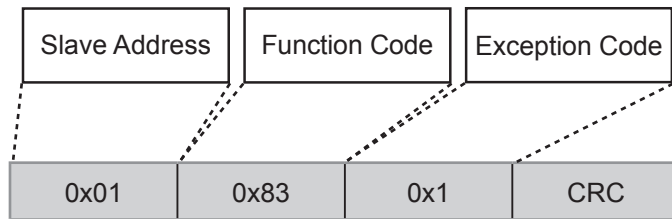

### 9.3.3 User-defined Communication Protocol for Data Log Reading

(1) Take an approach similar to Modbus RTU mode. The Modbus Master sends out Request using Function Code 0x03, which requests the Slave to response the value of the corresponding Modbus address. The Modbus Slave will provide the value through Response.

Example:

If a Modbus Master (such as PLC or data collector) uses a user-defined communication protocol to read the data log, the address is 0x0800. The packet format of Request sent by Modbus Master is as follows (Similar as Modbus RTU, but the Number of Points can only be 1):

### Master Request

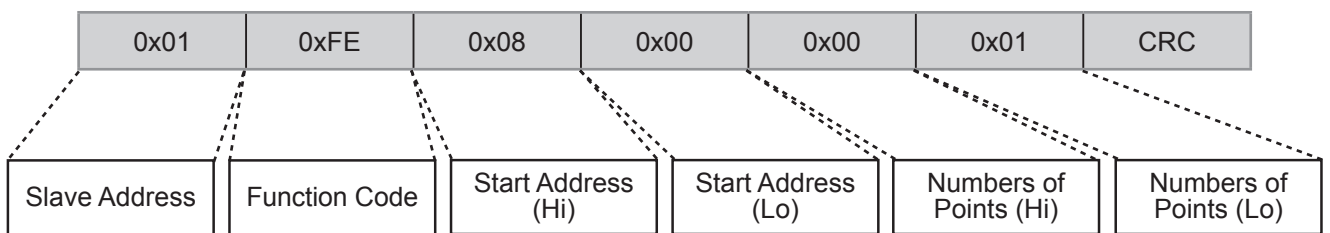

The packet format of Response responded by Modbus Slave (Power Meter) is as follows: (Similar to Modbus RTU before Byte Count. The only difference is that the data is a sting of Log data, and the sequence is as listed as follow. The total size is 66 bytes.)

### Slave Response

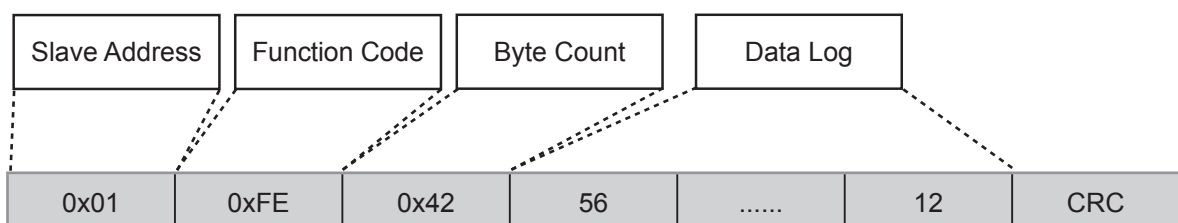



Sequential order	item	Data size(byte)	Sequential order	
1	Year	1		
2	Month	1		
3	Day	1		
4	Hour	1		
5	Minute	1		
6	second	1		
7	Average phase voltage(V)	4	Low word	High byte
				Low byte
			High word	High byte
				Low byte
8	Average line voltage(V)	4	Low word	High byte
				Low byte
			High word	High byte
				Low byte
9	Average current(A)	4	Low word	High byte
				Low byte
			High word	High byte
				Low byte
10	Neutral Current (A)	4	Low word	High byte
				Low byte
			High word	High byte
				Low byte
11	Power factor	4	Low word	High byte
				Low byte
			High word	High byte
				Low byte
12	Displacement PF	4	Low word	High byte
				Low byte
			High word	High byte
				Low byte
13	Active power(kW)	4	Low word	High byte
				Low byte
			High word	High byte
				Low byte

Sequential order	item	Data size(byte)	Sequential order	
14	Reactive power(kVAR)	4	Low word	High byte
				Low byte
			High word	High byte
				Low byte
15	Apparent power(kVA)	4	Low word	High byte
				Low byte
			High word	High byte
				Low byte
16	Positive active energy (Wh)	4	Low word	High byte
				Low byte
			High word	High byte
				Low byte
17	Opposite active energy(Wh)	4	Low word	High byte
				Low byte
			High word	High byte
				Low byte
18	Positive reactive energy (VARh)	4	Low word	High byte
				Low byte
			High word	High byte
				Low byte
19	Opposite reactive energy (VARh)	4	Low word	High byte
				Low byte
			High word	High byte
				Low byte
20	Positive apparent energy (VAh)	4	Low word	High byte
				Low byte
			High word	High byte
				Low byte
21	Opposite apparent energy (VAh)	4	Low word	High byte
				Low byte
			High word	High byte
				Low byte

# Appendix

## Appendix 1: Selecting Accessories

Current Transformer:

Should input current exceed rated current tolerated by the meter specifications, the power meter needs to be used together with a current transformer (CT). Users can select a suitable CT according to the table below.



Model	Primary Current (A)	Secondary Current (A)	Burden (VA)	Accuracy (%)	Size (mm)	
					Outer frame	Inner frame
DCT-S301C	100A	5A	1.5VA	1.0%	Outer frame	115*89*51
					Inner frame	32*21*32
DCT-S211C	200A	5A	1.5VA	0.5%	Outer frame	115*89*51
					Inner frame	32*21*32
DCT-S221C	300A	5A	2.5VA	0.5%	Outer frame	115*89*51
					Inner frame	32*21*32
DCT-S231C	400A	5A	3.75VA	0.5%	Outer frame	115*89*51
					Inner frame	32*21*32
DCT-S241C	500A	5A	5VA	0.5%	Outer frame	145*116*51
					Inner frame	80*50*32
DCT-S251C	600A	5A	5VA	0.5%	Outer frame	145*116*51
					Inner frame	80*50*32
DCT-S261C	750A	5A	5VA	0.5%	Outer frame	145*116*51
					Inner frame	80*50*32
DCT-S271C	1000A	5A	10VA	0.5%	Outer frame	145*116*51
					Inner frame	80*50*32
DCT-S281C	1500A	5A	10VA	0.5%	Outer frame	196*146*51
					Inner frame	122*80*32
DCT-S291C	2000A	5A	10VA	0.5%	Outer frame	250*186*51.4
					Inner frame	160.5*81*32
DCT-S2A1C	2500A	5A	15VA	0.5%	Outer frame	250*186*51.4
					Inner frame	160.5*81*32
DCT-S2B1C	3000A	5A	20VA	0.5%	Outer frame	250*186*51.4
					Inner frame	160.5*81*32

\*All models are not UL-certified.

Notes on selecting a current transformer

1. For the current transformer, the model with a closer maximal current on the primary side should be selected according to the maximal current actually input.  
For example: When the maximal current input is 700 A, DCT-S261C can be selected.
2. Wire over-length on the secondary side of the current transformer causes decrease in accuracy.



Smarter. Greener. Together.

## **Industrial Automation Headquarters**

### **Delta Electronics, Inc.**

Taoyuan Technology Center  
No.18, Xinglong Rd., Taoyuan City,  
Taoyuan County 33068, Taiwan  
TEL: 886-3-362-6301 / FAX: 886-3-371-6301

## **Asia**

### **Delta Electronics (Jiangsu) Ltd.**

Wujiang Plant 3  
1688 Jiangxing East Road,  
Wujiang Economic Development Zone  
Wujiang City, Jiang Su Province,  
People's Republic of China (Post code: 215200)  
TEL: 86-512-6340-3008 / FAX: 86-769-6340-7290

### **Delta Greentech (China) Co., Ltd.**

238 Min-Xia Road, Pudong District,  
ShangHai, P.R.C.  
Post code : 201209  
TEL: 86-21-58635678 / FAX: 86-21-58630003

### **Delta Electronics (Japan), Inc.**

Tokyo Office  
2-1-14 Minato-ku Shibadaimon,  
Tokyo 105-0012, Japan  
TEL: 81-3-5733-1111 / FAX: 81-3-5733-1211

### **Delta Electronics (Korea), Inc.**

1511, Byucksan Digital Valley 6-cha, Gasan-dong,  
Geumcheon-gu, Seoul, Korea, 153-704  
TEL: 82-2-515-5303 / FAX: 82-2-515-5302

### **Delta Electronics Int'l (S) Pte Ltd**

4 Kaki Bukit Ave 1, #05-05, Singapore 417939  
TEL: 65-6747-5155 / FAX: 65-6744-9228

### **Delta Electronics (India) Pvt. Ltd.**

Plot No 43 Sector 35, HSIIDC  
Gurgaon, PIN 122001, Haryana, India  
TEL : 91-124-4874900 / FAX : 91-124-4874945

## **Americas**

### **Delta Products Corporation (USA)**

Raleigh Office  
P.O. Box 12173, 5101 Davis Drive,  
Research Triangle Park, NC 27709, U.S.A.  
TEL: 1-919-767-3800 / FAX: 1-919-767-8080

### **Delta Greentech (Brasil) S.A**

Sao Paulo Office  
Rua Itapeva, 26 - 3° andar Edifício Itapeva One-Bela Vista  
01332-000-São Paulo-SP-Brazil  
TEL: +55 11 3568-3855 / FAX: +55 11 3568-3865

## **Europe**

### **Deltronics (The Netherlands) B.V.**

Eindhoven Office  
De Witbogt 20, 5652 AG Eindhoven, The Netherlands  
TEL: 31-40-2592850 / FAX: 31-40-2592851

\*We reserve the right to change the information in this catalogue without prior notice.