

INSTALLATION MANUAL

FOR

SD series 24V Sliding Gate Operators

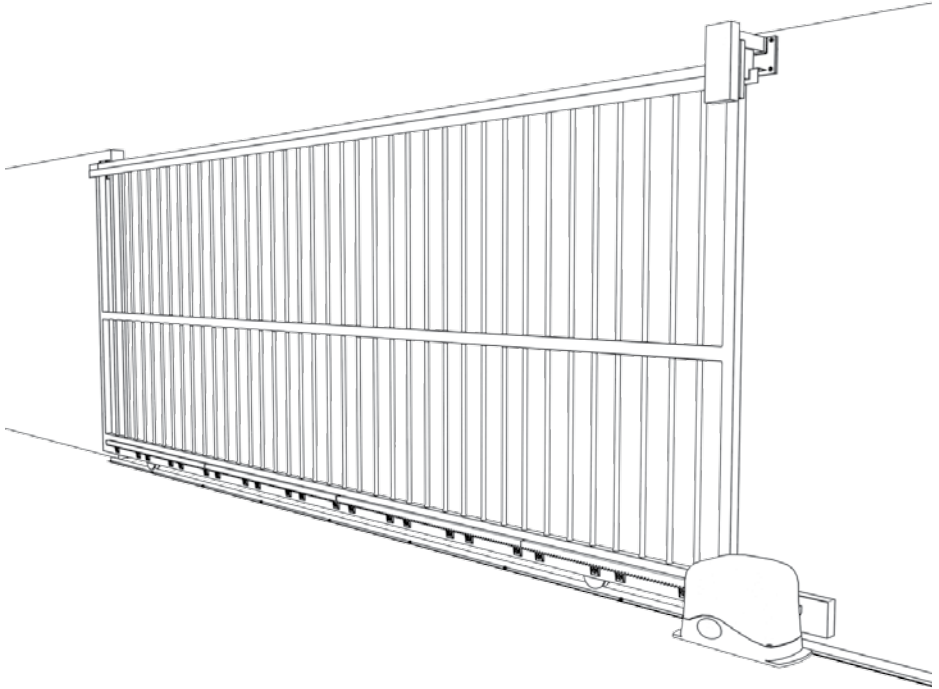

Developers and Manufacturers
of Automation Technology
www.grantsautomation.com.au

CONTENTS

PRE-INSTALLATION CHECK LIST	1
TECHNICAL SPECIFICATIONS	1
MAXIMUM SIZE OF GATE	2
GATE OPERATOR FREQUENCY OF USE	3
IMPORTANT SAFETY INSTRUCTIONS!	4
TOOLS AND HARDWARE REQUIRED	5
PREPARING THE GATE	6
GUIDE POST CLEARANCE	6
AUTOMATIC OPERATOR FITTING REQUIREMENTS	7
ACCESSORIES THAT CAN BE ADDED	8
SAFETY PHOTOCELL	8
DIGITAL KEYPAD AND/OR INTERCOM	9
A GROUND LOOP VEHICLE DETECTOR	9
CABLING REQUIREMENTS	10
BASIC CABLING GUIDE	10
FULL CABLING GUIDE	10
TYPE AND SIZE OF CABLE	11
HOW IT WORKS	12

INSTALLATION	13
STEP 1 - INSTALL CABLING	13
TIPS FOR RUNNING LOW VOLTAGE CABLE YOURSELF.	14
STEP 2 - FIT THE OPERATOR	14
POSITION OF THE OPERATOR	13
CHECK HEIGHT OF THE OPERATOR	15
RAISE THE HEIGHT OF THE OPERATOR IF NEEDED	15
FIX THE OPERATOR IN PLACE	16
MANUALLY RELEASE THE OPERATOR	16
STEP 3 - FIT THE RACK TO THE GATE	17
STEP 4 - POWER OPERATOR UP	21
WIRING DIAGRAM FOR POWER CONNECTIONS	21
CHECKING THE GATE DIRECTION	22
WIRING DIAGRAM FOR THE BATTERY	23
WIRING DIAGRAM FOR A PHOTOCCELL	24
WIRING DIAGRAM FOR DIGITAL KEYPAD OR PRESS BUTTON	24
WIRING DIAGRAM FOR AN INTERCOM	25
TERMINATING GROUND LOOP VEHICLE DETECTOR	24
TERMINATING A 7-DAY TIMER, DIGITAL KEYPAD OR KEYSWITCH	25
TERMINATING AN INTERCOM	25
STEP 5 - ACTIVATING THE REMOTE CONTROLS	26
STEP 6 - SETTING THE OPEN AND CLOSE LIMIT	27
STEP 7 - SET THE RAMP DOWN POSITION	28
STEP 8 - MAKING OTHER CHANGES	29
INSTALLING THE SOLAR PANEL	30
WHAT HAPPENS IF THERE IS A POWER CUT?	31
ACCESSORIES	32
TROUBLE SHOOTING	32
WARRANTY	33

PRE-INSTALLATION CHECK LIST

TECHNICAL SPECIFICATIONS

ELECTRICAL

Power Supply SD-240, SD-LVC, SD-LVH:	240VAC 50Hz
Power Supply SD-SOL:	Solar Panel
Electronic Controller:	Micro-controller based
Gate Obstruction Detection:	Over Current
Safety Barrier:	Photocell
Operating distance of remote controls	50m or more
Remote control buttons:	Open, Stop, Close, Ped open
Open and close limit type:	Encoder and Magnetic SW
Auto-close time:	0 to 99 seconds

MECHANICAL

Max. gate weight:	800kg
Gate Operating Speed:	22cm/second
Packing Size:	40 x 30 x 18.5cm
Noise:	less than 65db
IP Rating:	IP57
Working Temperature:	-15°C to 55°C

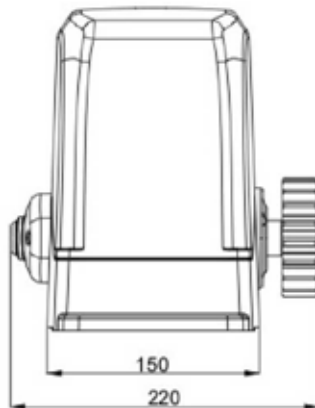
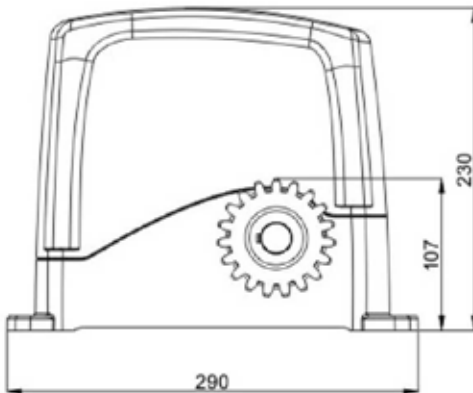

(Unit: mm)

**MAXIMUM SIZE OF GATE FOR THE SD-240, SD-LVH AND SD-SOL OPERATORS
FOR SD-LVC REDUCE THIS BY 40%**

For Aluminium Gates with vertical bars or Chain Link Gates:

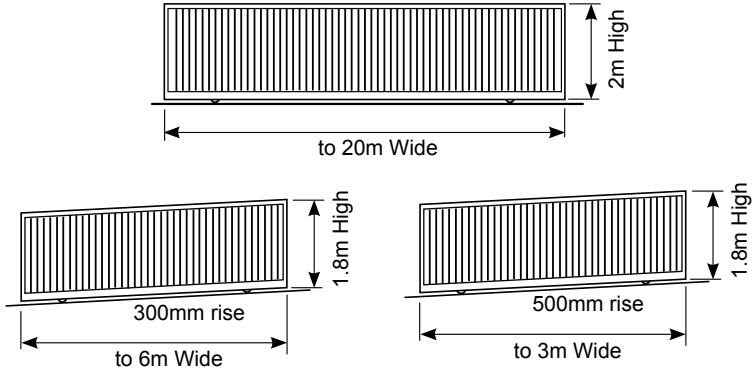

**For Galvanised Steel Gates with vertical bars, Aluminium Gates with Slats
or 16mm thick pine palings:**

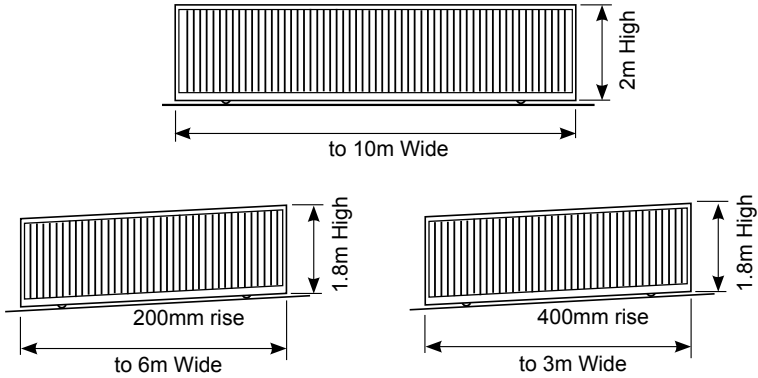

For Heavy Galvanised Steel Gates or Gates with Hardwood Cladding:

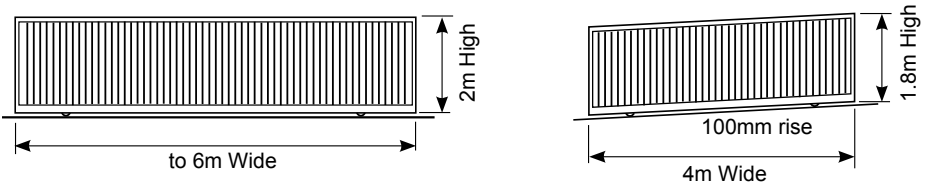

GATE OPERATOR FREQUENCY OF USE

This Gate Operator is rated for **RESIDENTIAL AND LIGHT INDUSTRIAL USE ONLY**, which is a maximum of Five Households or Ten Carpark spaces for a commercial building. Any more than this and the life span of the operator can be reduced.

The warrantee does not cover wear and tear due to average use of more than 60 operations per day.

If higher frequency of use is required consider using an industrial sliding gate operator rated for continuous use. Gates that have a lot of users are more likely to be struck by a vehicle so need to be a robust industrial grade operator.

Battery Back Up System

If a Battery Back Up is used the 24V 7Ah battery takes over if the mains power fails. It will provide up to 200 operations over a couple of days or last a week or so if not used.

Battery Conditioning During Normal Use

During normal use when the motor starts up it draws power from the battery, which keeps it conditioned for reliable operation as batteries need to be used regularly for them to work properly.

Low Voltage Power Cable

The Battery Conditioning arrangement also allows the power transformer to be away from the gate and Low Voltage Power Cable only run to the gate. This is because any current that is too high for the low voltage cable is taken up by the battery. This means that the operator **must have a battery connected** before it will work properly with Low Voltage cabling.

Solar Powered

Run from the Battery during normal use, which is charged from a solar panel. The 14Ah battery supplied will run for up to 12 to 24 operations per day depending on the weight of the gate for 10 cloudy days in a row. A 20Watt Solar panel will charge the battery from flat in two days of full sun. If you are in an area that doesn't get a lot of sun you may need to add extra solar panels and batteries, which are available as extra's.

IMPORTANT SAFETY INSTRUCTIONS!

CONSIDERING THE GENERAL PUBLIC:

When Installing an Automatic Gate that will be entered from a public road way, make sure the Gate is placed far enough from the road to prevent traffic congestion.

The Gate must be installed in a location that provides adequate clearance between it and adjacent structures when opening and closing to reduce risk of entrapment.

Install the Gate Operator on the inside of the property and fence line. **DO NOT** install an opener on the outside of the gate where the public has access to it.

The Gate and Gate Operator must comply with any applicable local council regulations.

CONSIDERING THE USERS:

If using the Auto-close feature it is highly recommended that a Point to Point Photo Electric Safety Beam (Photocell) is installed to prevent the gate closing on any vehicle using the gate.

It is also recommended that a separate small side gate is used for pedestrians particularly if there will be children, disabled or elderly people using the gate.

If push buttons, key switches or Digital Keypads are installed, they should be within sight of the gate but not placed so the user will be tempted to reach through the gate to activate the gate operator.

USER AWARENESS:

It is important to make sure everyone that will be using the gate is aware of the following dangers associated with automatic Gates: do not contact any part of the gate or walk in the path of the gate while it is moving. Never let children play with the gate controls. Do not attempt to "beat the gate" while it is closing. This is extremely dangerous.

In the event you sell the property, make sure the new owners have a copy of these instructions. If you lose the instructions they can be downloaded from: www.grantsautomation.com.au.

TOOLS AND HARDWARE REQUIRED

THE TOOLS YOU'LL NEED INCLUDE:

A basic set of hand tools will be needed including: side cutters, pliers, wire strippers, a range of phillips head screw drivers, a small flat head screw driver for terminal block screws and a socket set.

You'll also need a tape measure, marking pen, an electric drill with hammer action and variable speed control, a 10mm hammer drill bit and socket bit for 10mm or 3/8" tek screws. An angle grinder is also handy although a hacksaw will do if you don't have one.

If you intend on doing your own low voltage cabling a pair of conduit cutters are handy although a hacksaw can also be used. If you wish to run cabling across the driveway you will need either a 230mm angle grinder with masonry grinding disc or a hand held concrete cutter. You can hire these if necessary. If you'll be running cabling across a lawn or garden you'll need a spade and mattock for digging a low trench. If it's a long run then a small trench digger can be hired to do the job.

YOU MAY ALSO NEED THESE ITEMS BEFORE INSTALLATION

For Battery Powered Systems and systems with accessories added **Low Voltage Cable is required** between the Transformer and the Gate operator see "Cabling Requirements" for more information.

You may also need conduit, which is available from Electrical trade suppliers and hardware stores.

For Mains Powered Systems you will need a mains power point mounted on a free standing post in front of the gate next to the automatic operator. Check with local regulations before installing a mains voltage power point yourself, you may need a registered electrician to do this for you.

PREPARING THE GATE

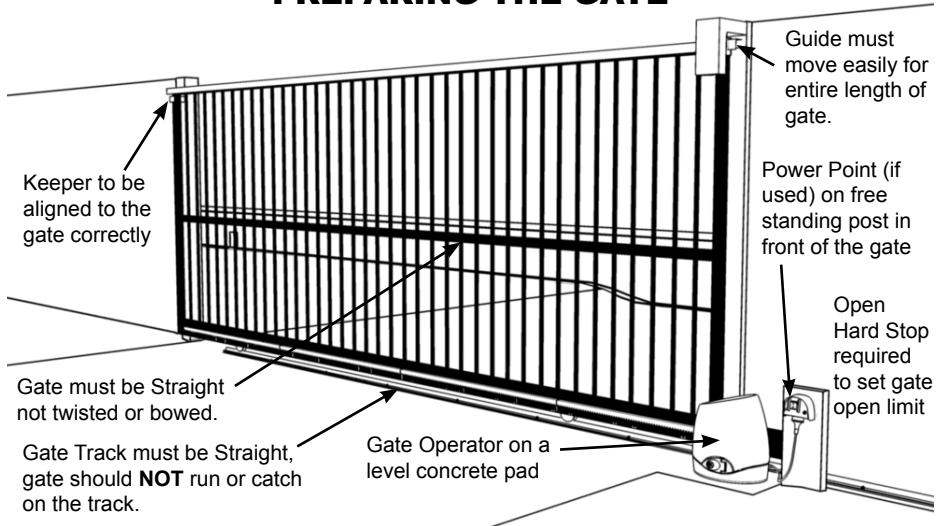

Make sure that the gate has been properly installed, is straight and slides freely throughout its entire length without any grabbing from the guides or track anywhere along the gate. The **GATE TRACK MUST BE IN A STRAIGHT LINE** any sudden dips or rises may prevent the gate operator from working properly. Repair or replace all worn or damaged gate hardware prior to installation. Gate posts less than 150mm wide should be made from steel not timber. Replace posts where necessary. A freely moving gate will require less force to operate and will enhance the performance of the operator and give a long working life.

The operator should be well drained and not be submersed in water or have water running past it in heavy rain.

GUIDE POST CLEARANCE

If using a guide post behind a gate allow at least 60mm clearance for the Rack. If the guide is fitted to the front Fence or Wall the clearance has no effect so long as the Gate does not contact it at all.

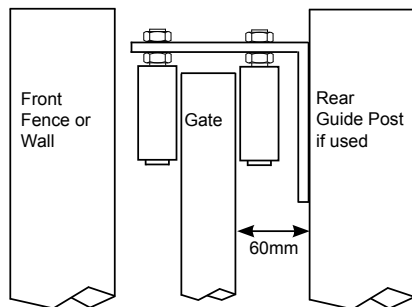

ACCESSORIES THAT CAN BE ADDED

SAFETY PHOTOCELL

Photocells are a safety device that prevent the gate from closing on a vehicle. They are **highly recommended** if using the **Auto-close** feature, as the gate may close at any time.

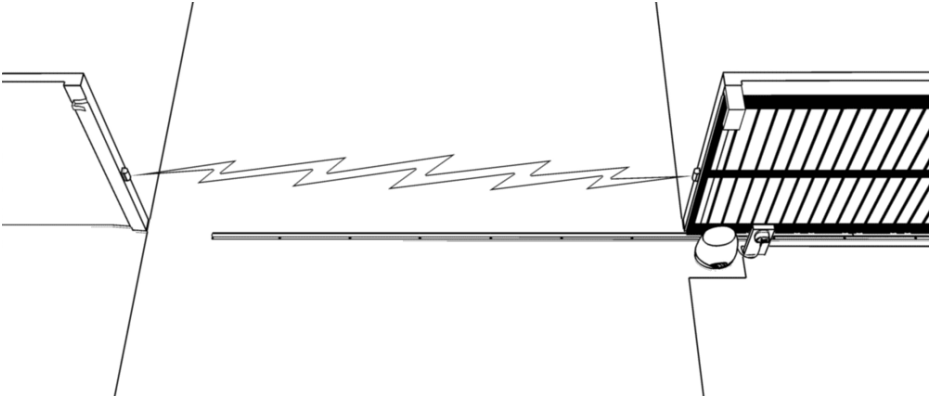

A Photocell consists of an Invisible Low Power Infrared point to point Beam Transmitted from one side of a gate to the other. **REFLECTOR BEAMS** are **NOT** recommended for outdoors.

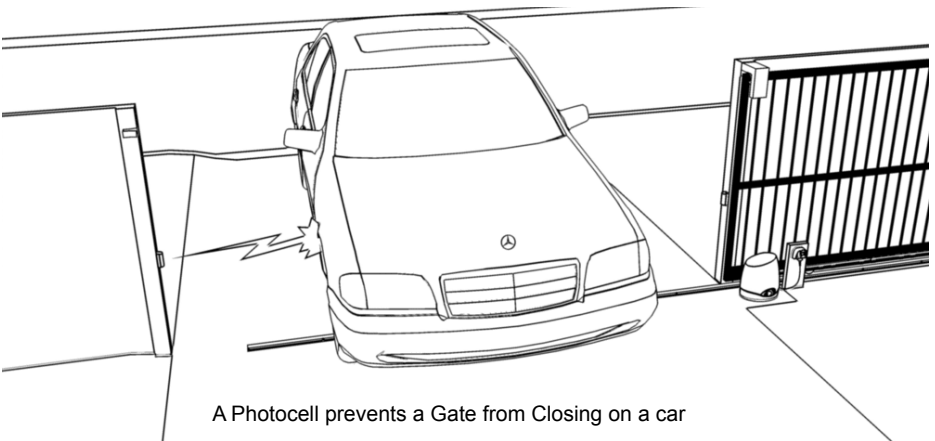

If the Photocell's beam is interrupted by a vehicle, the gate won't close.

DIGITAL KEYPAD AND/OR INTERCOM

To allow access to visitors or tradesman any brand of digital keypad and/or intercom can be installed (provided the intercom has a door release feature).

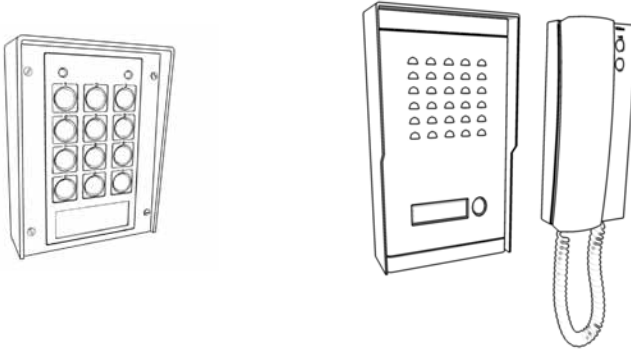

A Digital Keypad allows access to anyone with the correct pin number.

An Intercom allows visitors to call the house and speak with the occupier. If the occupier wishes to let the visitor in they can do so by pressing a button on the intercom to open the gate.

CABLING REQUIREMENTS

BASIC CABLING GUIDE

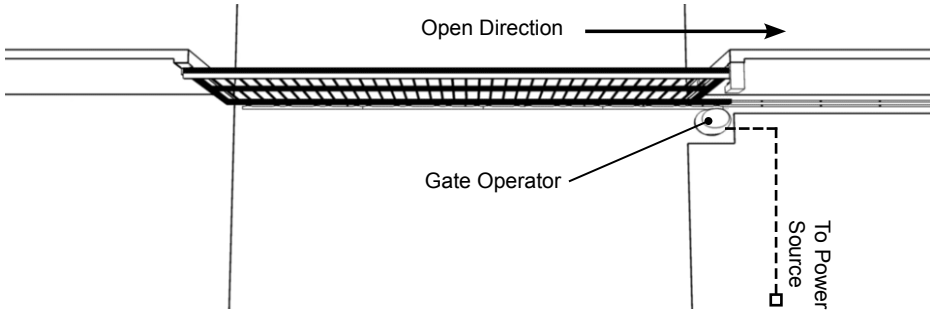

FULL CABLING GUIDE RIGHT HAND GATE

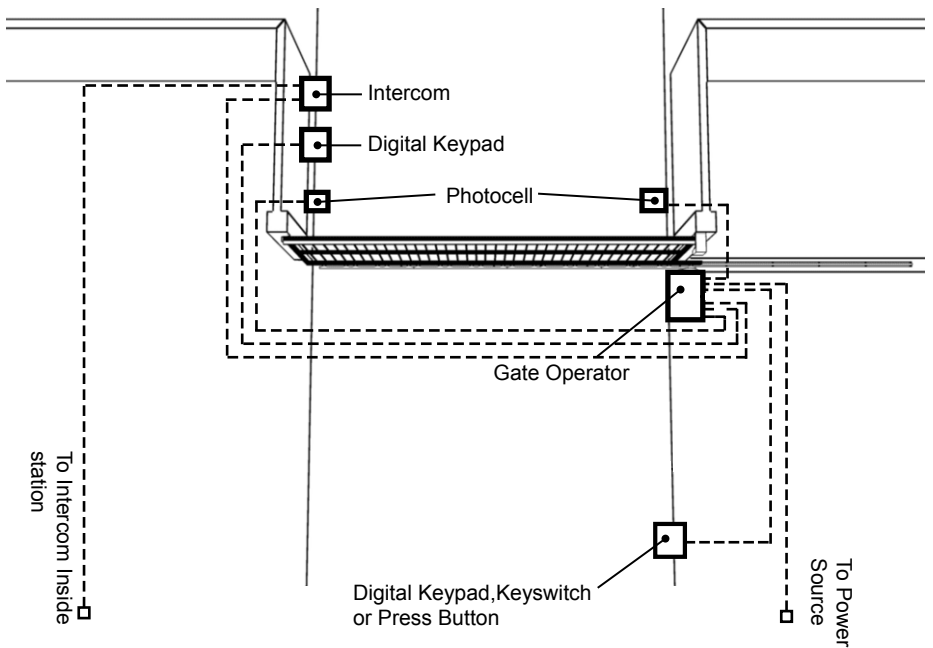

The Gate Operator will be on the other side for a left hand gate. If power source is 240VAC Mains the cable for this should be kept at least 100mm away from any low voltage cabling.

TYPE AND SIZE OF CABLE

240V Mains at Gate

Mains power is best hard wired to the operator. If an outdoor power point is used the can be turned off so is NOT recommended. You will need a registered electrician to do this for you.

Low Voltage Systems

Don't need a register electrician because all power at the gate is 24V. A plug in transformer is supplied that can plug in anywhere there is power or can be hard wired by an electrician. Low Voltage Garden Lighting Cable only is required between the transformer and the gate operator. 2mm² cable is good for up to 25m and 4mm² for up to 50m.

For Accessories

0.4mm Diameter (0.12mm²) or 0.65mm Diameter (0.33mm²) Outdoor telephone cable is ideal for Connecting Photocells, Digital Keypads and Intercoms as this cable has a tough outer sheath and is gel filled to protect it from moisture. Cat 5 and indoor phone cable is fine to use so long as it isn't exposed to moisture for prolonged periods. If using security cable this must be a conduit that is fully sealed to prevent any exposure to moisture other wise it can rot in the ground.

HOW IT WORKS

The SD series Gate Operator consists of an electro-mechanical drive unit with built in Electronic Controls.

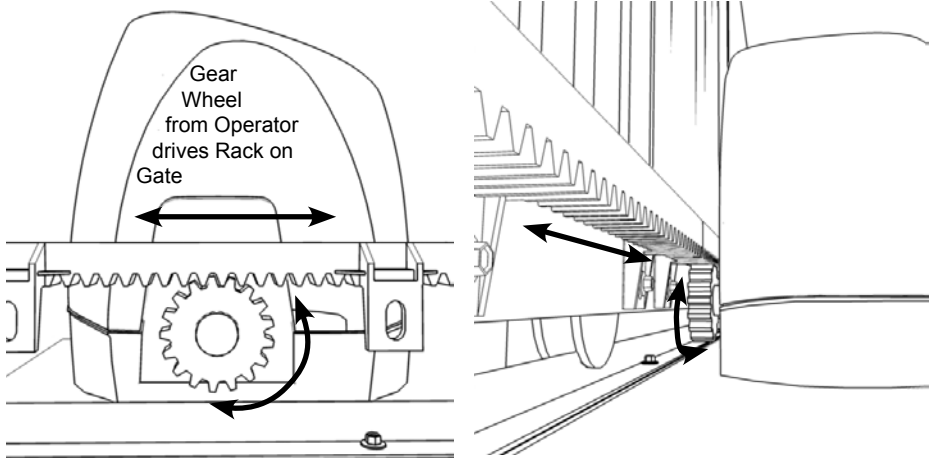

When the operator is activated by remote control or other device, it drives the gate open or closed by way of a toothed rack fitted to the gate that engages with a Gear Wheel on the operator. Magnets are fitted to the rack to set the open and close limit of the gate, which is detected by a sensor in the operator. A built in encoder sensors the distance the gate is travelled accurately controlling the ramp up and ramp down of the motor speed and the open and close limits.

INSTALLATION

STEP 1 - INSTALL CABLING

Always get a registered electrician to install any 240V mains voltage cabling for you other wise any cable for voltage lower than 32VAC or 50VDC you can do your self without a license.

If your gate track is hollow you can run low voltage cabling through this but be carefull that the cable doesn't doesn't get pinced anywhere along the track particularly when a vehicle drives over it. If you need to run Low Voltage Cable across a concrete or bitumen driveway or path you can do this by chasing a groove with a 9" angle grinder with a diamond cutting blade fitted. Make the groove deep enough so there is 5mm or so space above the cable when installed and wide enough so the cable sits loosly in the groove. Use an expansion gap where possible as this requires less work. Make sure the cable will not be pinched if between two slabs of concrete that can shift with ground movement.

Fix the cable into the groove using clear plumbers silicon (non acidic) or other flexible sealer in the clean groove before the cable and again after, making sure it sticks to both sides of the groove. If the path or driveway has lawn or garden edges make sure the cable isn't exposed or accessable to edge trimmers or spades by running the groove down the edge and into conduit just under the edge of the driveway. You'll need to dig a hole next to the driveway to do this.

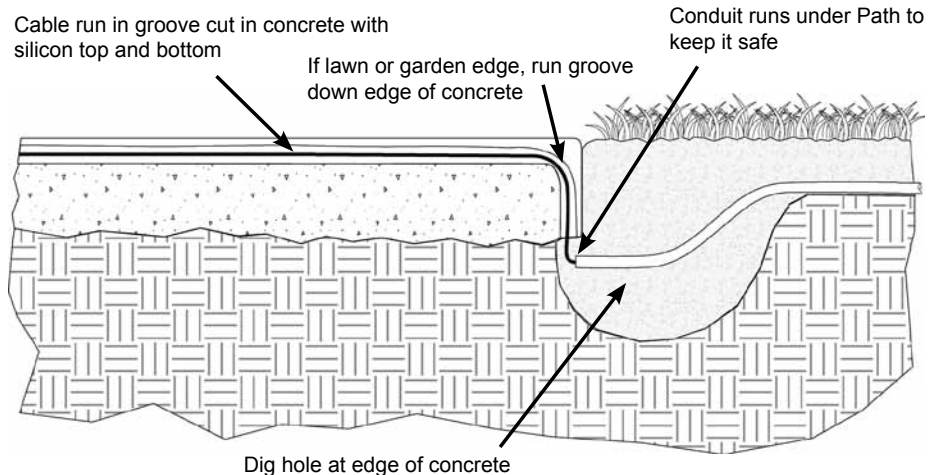

If the driveway meets a post and you need to go around it then chase a groove where you can with the angle grinder then use a rotary hammer drill as a mini jack hammer for the corners and fiddly bits.

TIPS FOR RUNNING LOW VOLTAGE CABLE YOURSELF.

- ⚡ Always use conduit if running cable in grass, open ground, gardens or pebbles. Grey conduit is best.
- ⚡ Conduit should be buried deep enough so it is out of harms way. For existing lawns, pebbled areas or if run along side a driveway then buried just below the surface is fine. For open ground, gardens and area's where there is likely to be other digging going on then conduit should be buried at least 300mm deep.
- ⚡ Never make joints in cable directly in the ground. If you must join cable, either bring it up well above the ground and have the joint protected from the elements by a weather proof junction box or put a pit in the ground to make sure the joint is sitting in the air within the pit and cannot be submerged in water.

STEP 2 - FIT THE OPERATOR

POSITION OF THE OPERATOR

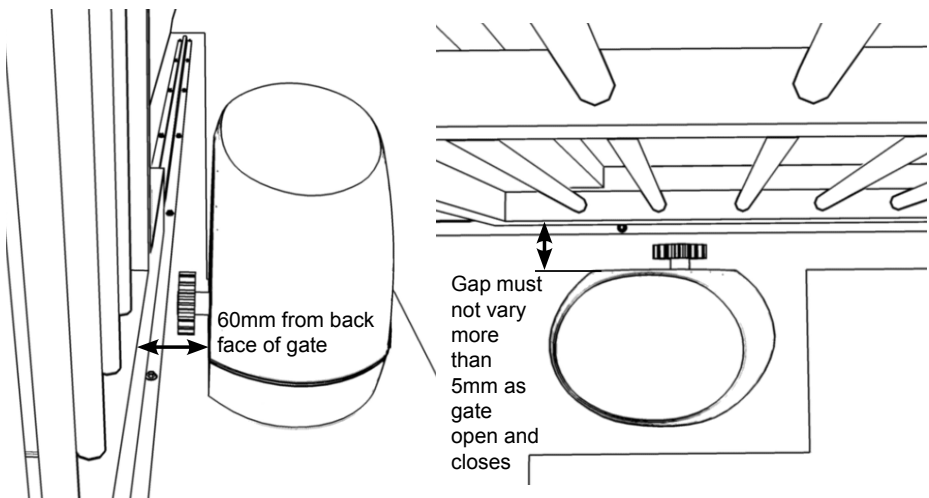

Place the Operator on it's concrete pad 60mm from the back face of the gate then open and close the gate checking that this distance does not vary more the 5mm each way as you go, other wise the gate and/or track is not straight enough and the gear wheel may not contact the rack well enough.

CHECK HEIGHT OF THE OPERATOR

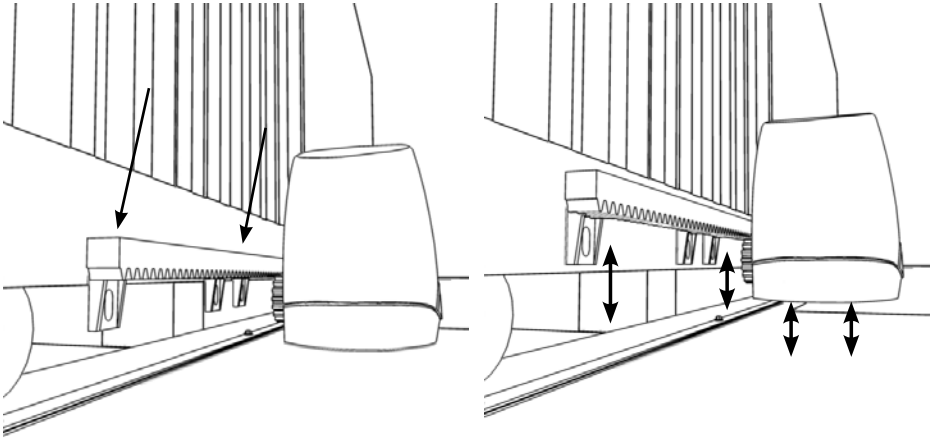

With the Operator sitting on it's concrete pad (not fixed in place yet), place a length of rack on the gear wheel and check its alignment with the bottom rail of the gate.

If the mounting holes for the rack are below the bottom edge of the gate, then the Operator will need to be raised up.

RAISE THE HEIGHT OF THE OPERATOR IF NEEDED

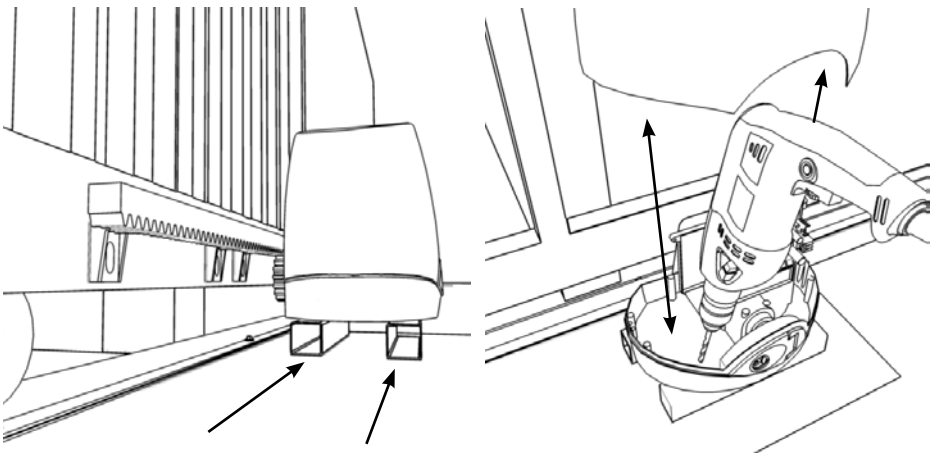

Raising the Height of the operator can be done with a couple of short lengths of box section or make up a mounting frame out of box section.

There are holes in the bottom of the operator for attaching a mounting frame.

FIX THE OPERATOR IN PLACE

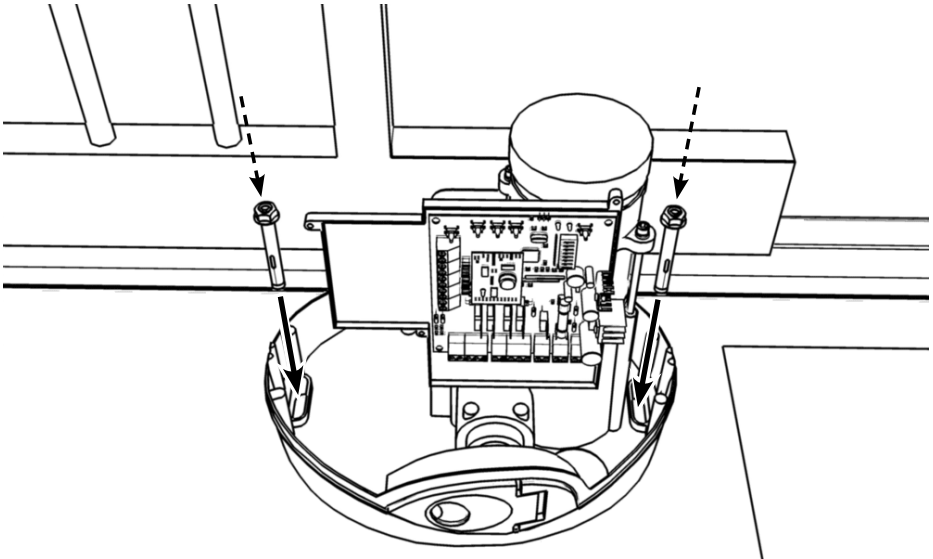

Fix the Operator to it's Concrete Pad using M10 x 50mm Dyna bolts or longer if the Operators height had to be raised. Use galvanised Dyna bolts if you can so they won't rust. Large raw plugs and galvanised screws may also be used if preferred. The important thing is, once the Operator is fitted, it doesn't work loose.

MANUALLY RELEASE THE OPERATOR

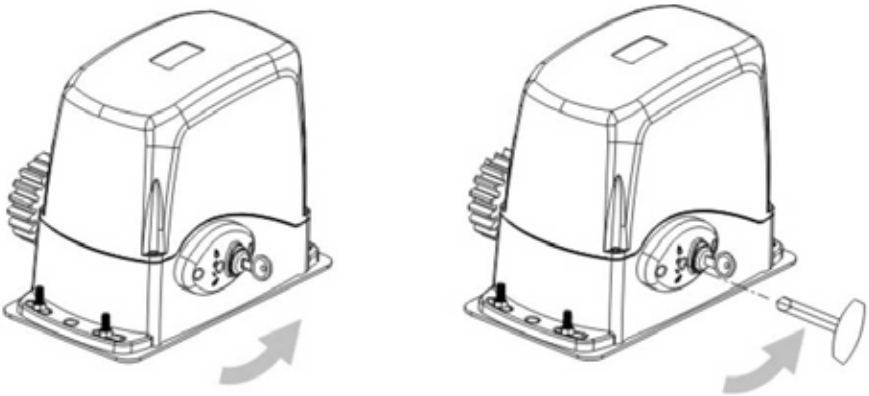

Put key in and rotate 90° clockwise. Then put allen key in and rotate that 90° clockwise

STEP 3 - FIT THE RACK TO THE GATE

Before fitting any rack, lay it out in front of the closed gate to see how it lines up. Start at the operator end, with the first length sitting on the operators gear wheel, adjusting the position of the rack as you go to make sure the mounting lugs miss the wheels. If the last length needs to be cut shorter, it must have at least two mounting lugs attached to the gate.

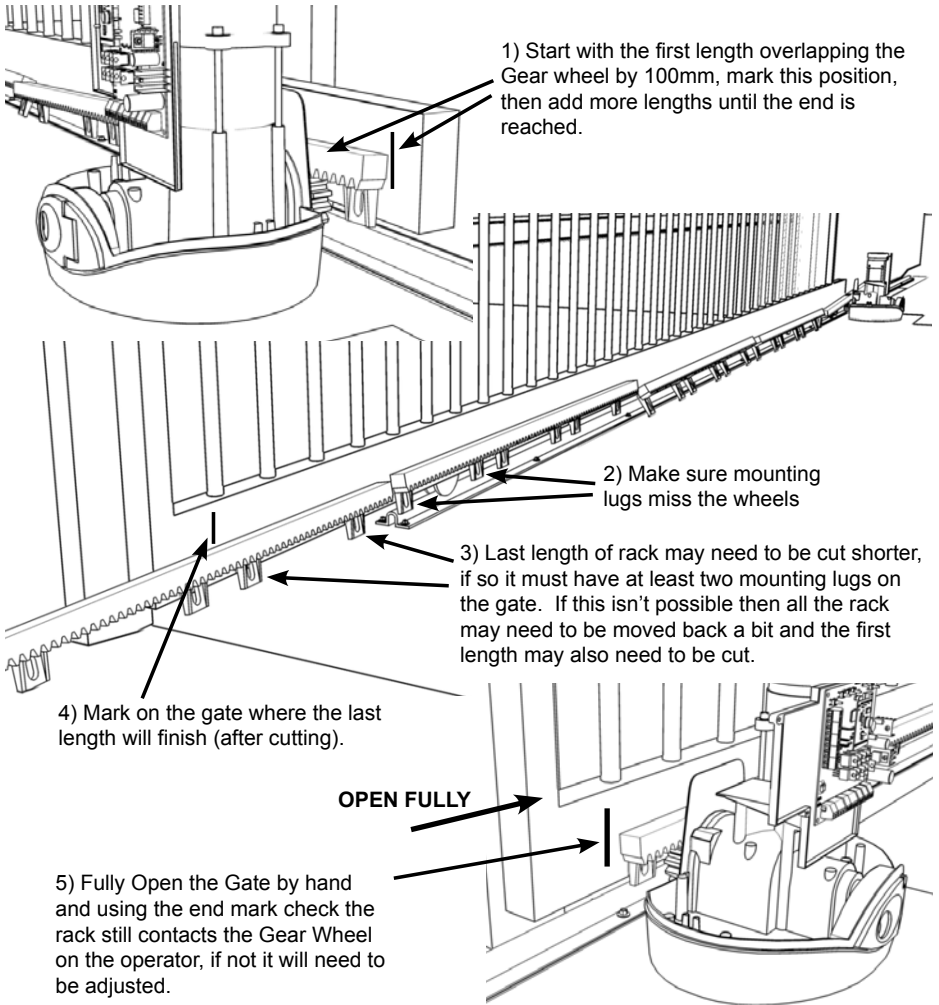

This gate operator has no magnet for the open limit so the rack can go right to the very end when the gate is open.

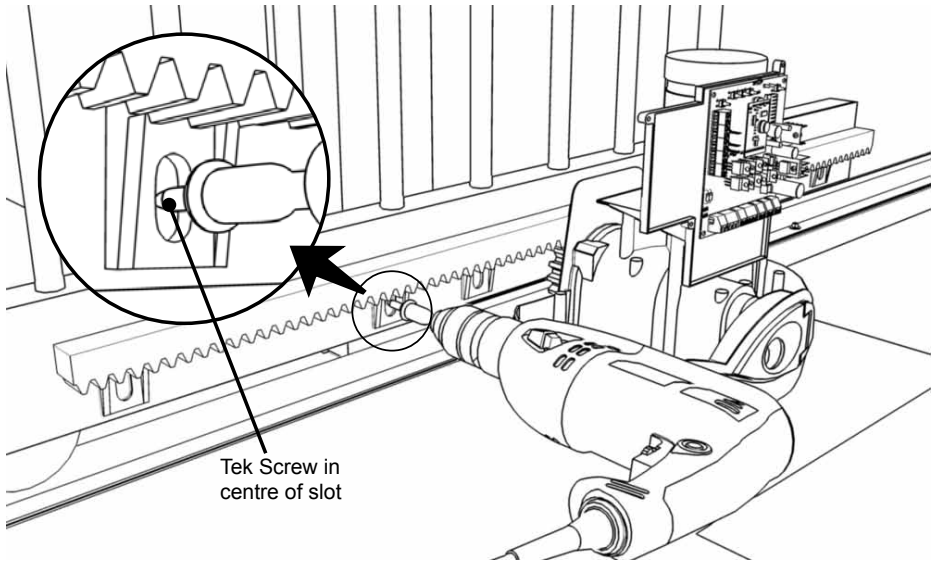

To fit the Rack, start with the gate nearly closed and place the first length of rack on the Operators Gear Wheel, in line with the mark you made earlier and the bottom rail. Drill 10mm (or 3/8") Tek screws into two of the mounting lugs for the rack, making sure they are both in the centre of each slot. Do not fully tighten at this stage, as the height of the rack needs to be adjusted.

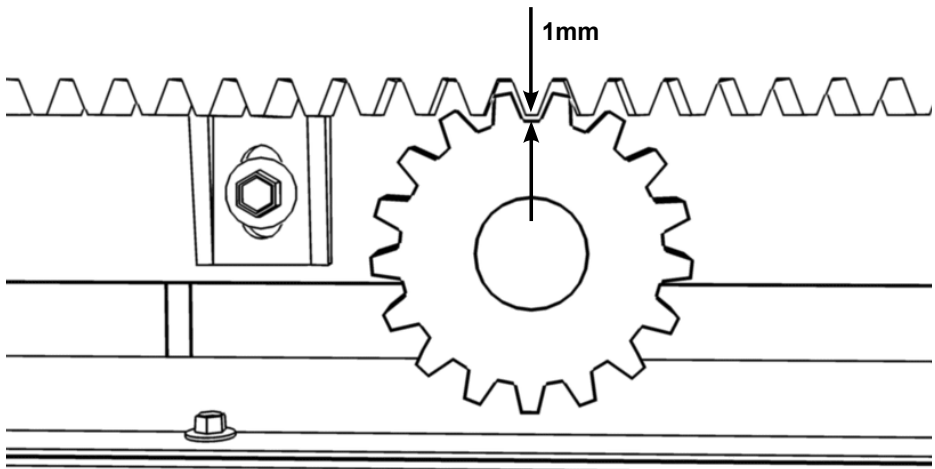

Move the gate by hand until each of the Tek screws is close to the gear wheel and adjust the height of the rack until it has about 1mm clearance above the gear wheel. Tighten the tek screws fully once the height is correct.

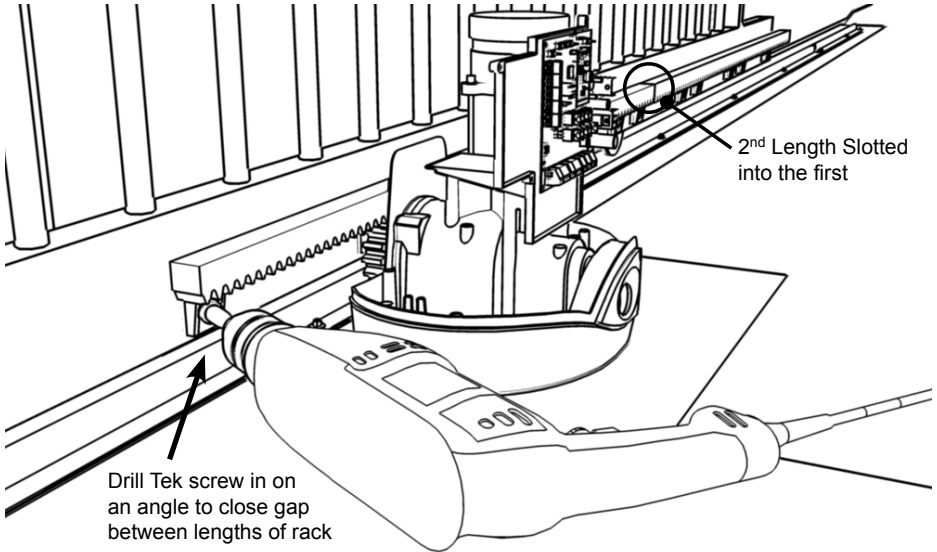

Now fit the 2nd length of rack by sliding the gate open a bit further and placing it so one end is slotted into the first length and the other end is sitting on the operators gear wheel, allowing enough room to drill another tek screw in. Drill the tek screw in on an angle to close up any gap between the two lengths.

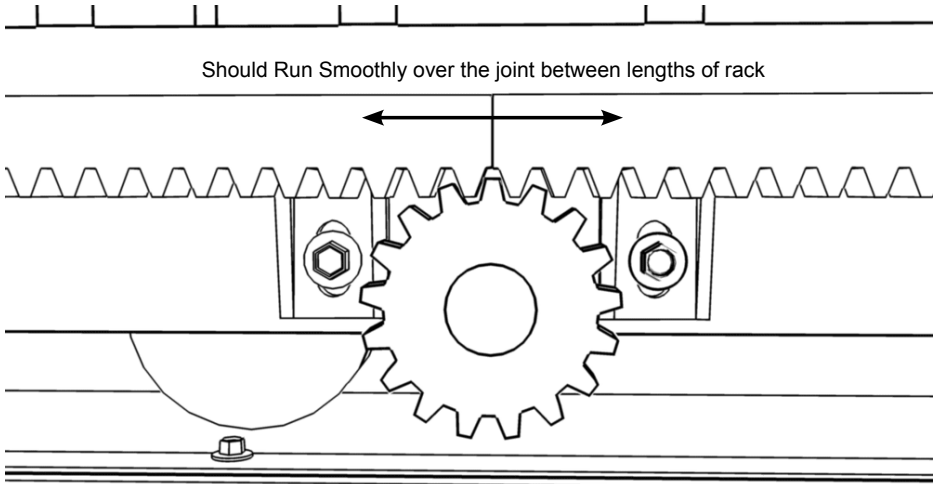

If the gate is now moved by hand and run over the join between the lengths of rack, there should be no jump, it should run smoothly over the join. Also set the 1mm clearance at the new tek screw position and tighten it up fully. Repeat the same with the remaining lengths of rack, just tacking them all in place for now with two tek screws.

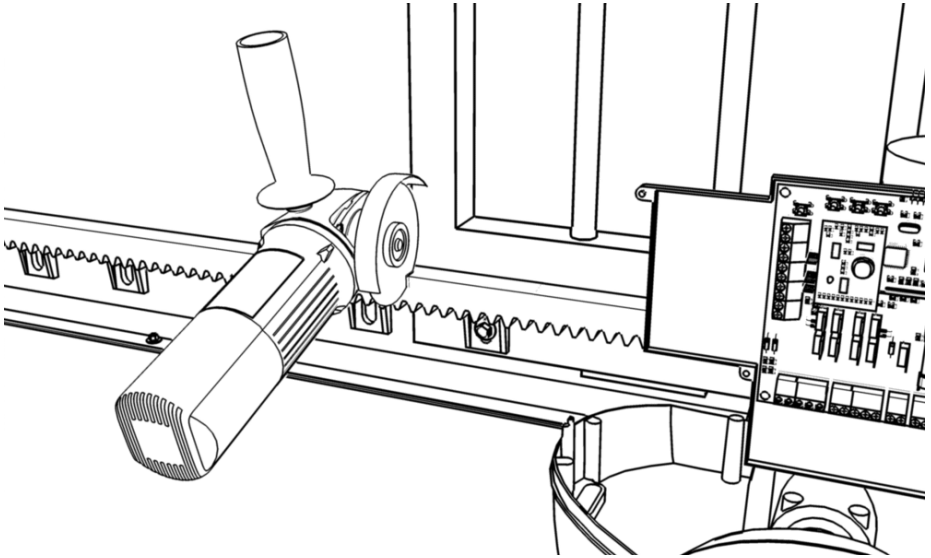

Once all lengths are tacked in place and the gate is opened and closed to check the rack contacts the gear wheel at all times then cut off any excess rack using an angle grinder or hack saw. The Rack may be plastic on the outside but it has a steel rod in the middle.

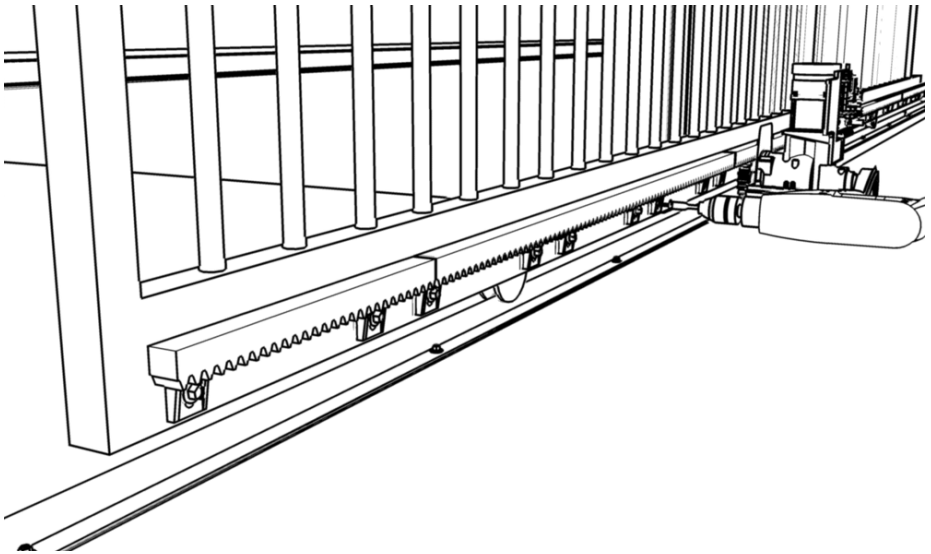

Now go through and tek screw **ALL MOUNTING LUGS** for the rack that haven't been done yet, adjusting the 1mm clearance from the gear wheel as you go. It is quicker to do these all in one run.

STEP 4 - POWERING OPERATOR UP

For the SD version with out a battery simply plug it into a power point and turn on the power switch to power it up. For versions with a battery back up connect the battery first then plug the power in or connect the solar panel.

A battery back up can be added to an SD Operator that doesn't have one at any time. The SD with a Low Voltage Option must have a battery back up before it will work properly.

Solar power gate operators can be connected to mains power after installation if you wanted.

WIRING DIAGRAM FOR MOTOR CONNECTIONS

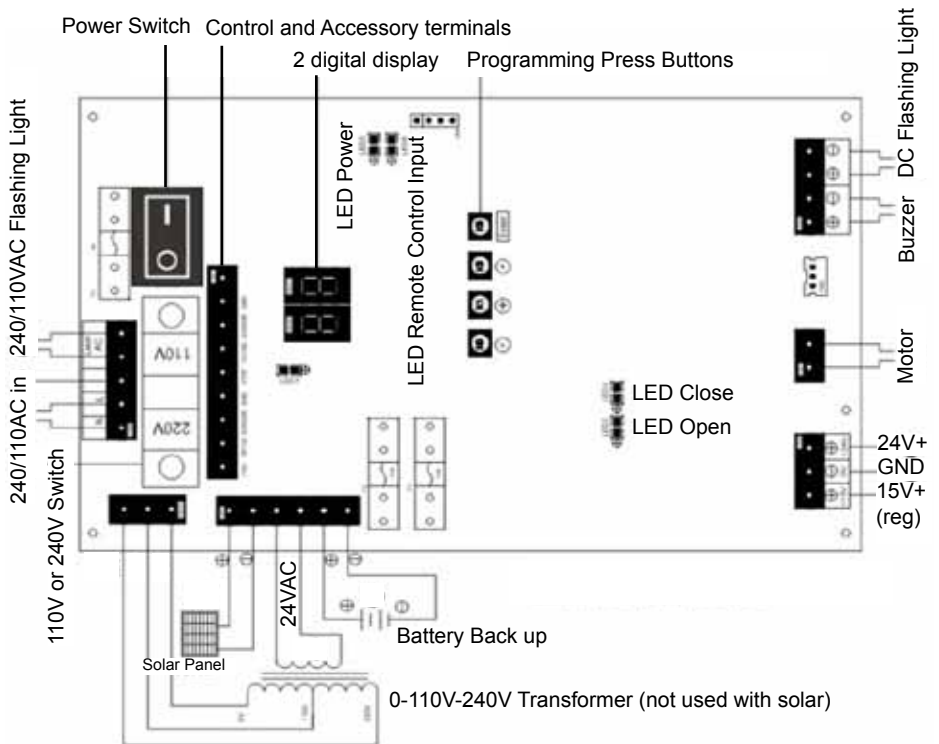

CHECKING THE GATE DIRECTION

The Gate Operator is prewired for a Right Hand Gate.



If you have a Left Hand Gate then you'll need to change the Motor Direction

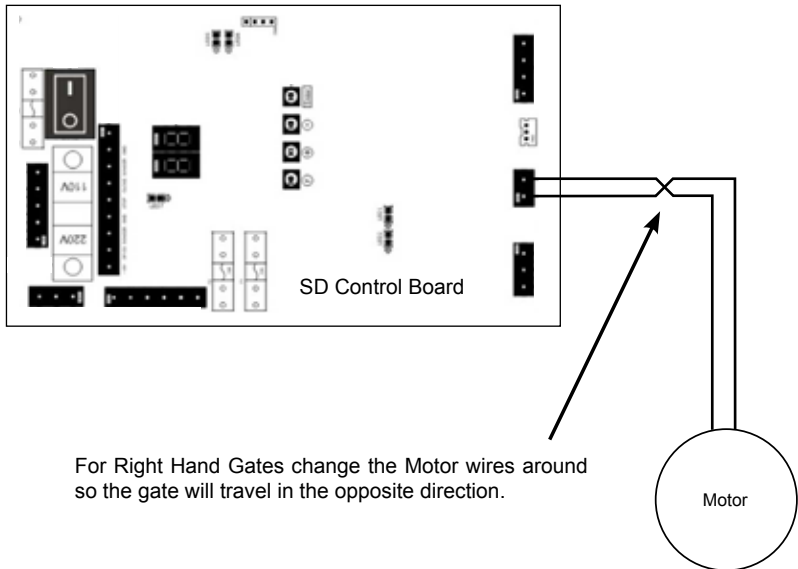
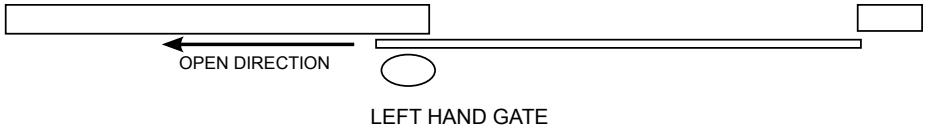

WIRING DIAGRAM FOR BATTERY BACK UP

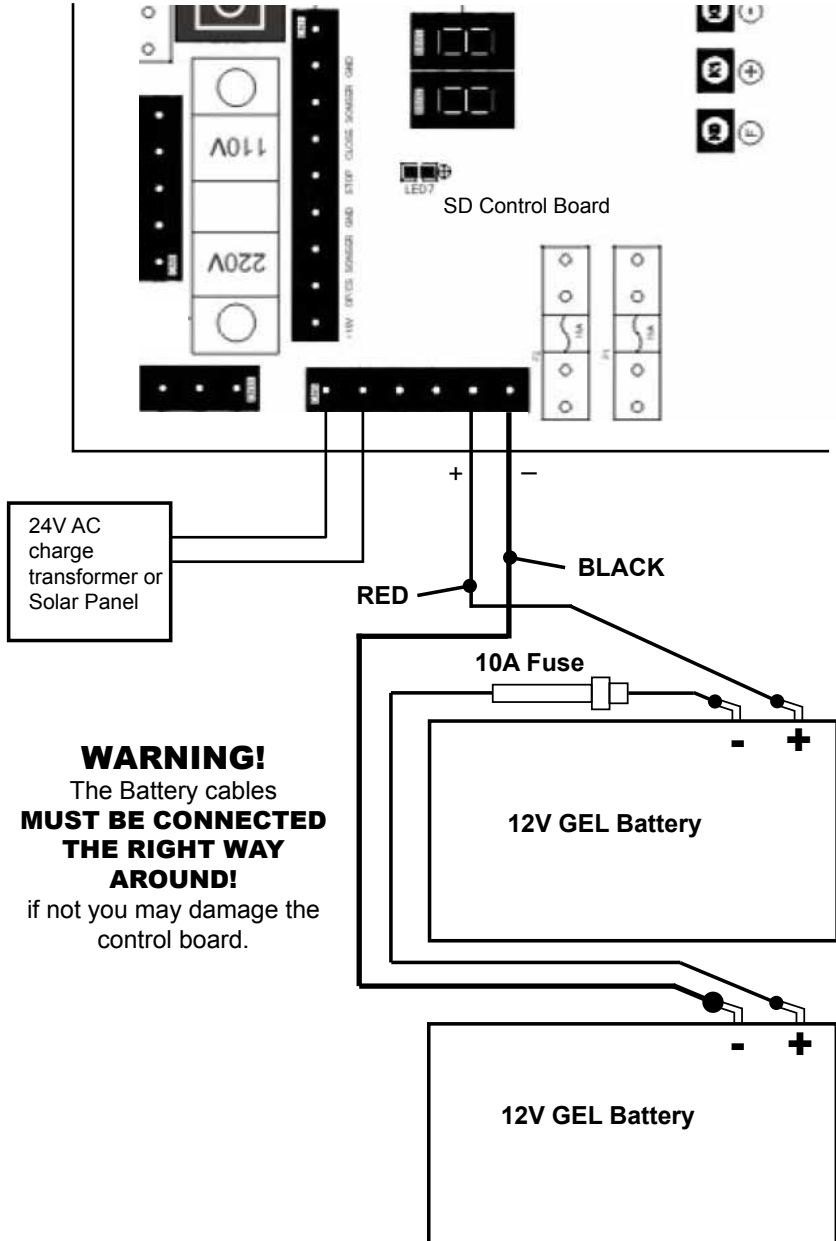

WIRING DIAGRAM FOR A PHOTOCELL

Safety Photocells are used to prevent the gate from closing on a vehicle. The gate will not close if the photocells light beam is broken. If a photocells light beam is broken while the gate is closing, the gate will reverse back open until the photocell is clear then the gate will close normally.

Control and Accessories Terminal of the SD Control Board

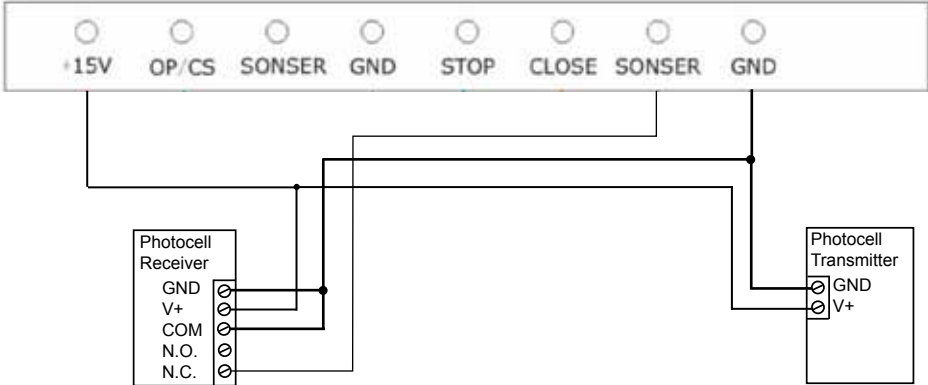

For Solar Powered SD Operators the power for the photocell should come from the DC Flashing light output so it is only present when the gate is operating

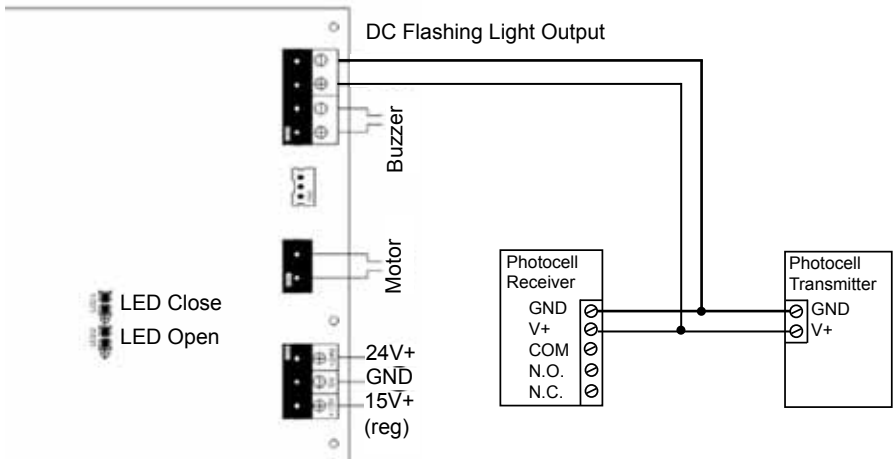

WIRING DIAGRAM FOR AN INTERCOM

Intercoms with a lock output can also be used to activate an automatic gate. Intercoms will either have a clean contact output that can be used as it is or a 12VAC or 12VDC output for an electric lock, which requires an optional adaptor.

Control and Accessories Terminal of the SD Control Board

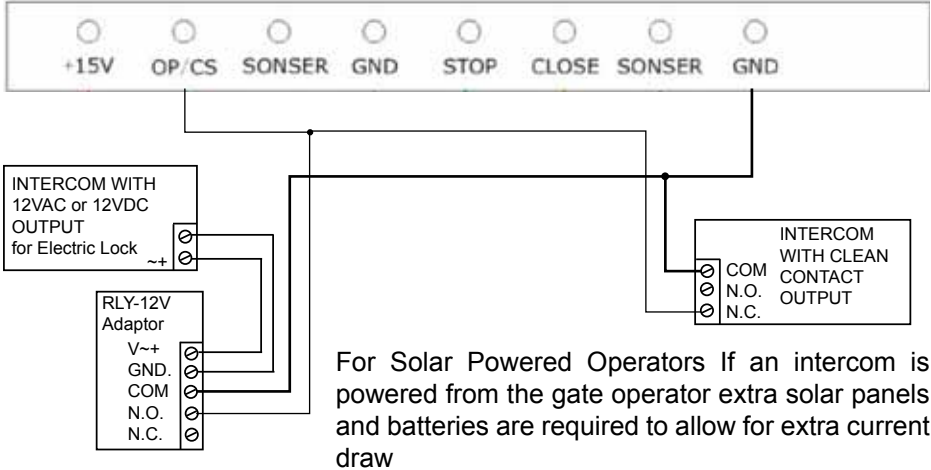

WIRING DIAGRAM FOR A DIGITAL KEYPAD OR PRESS BUTTON

A Digital Keypad or Press Button can be used to activate the gate.

Control and Accessories Terminal of the SD Control Board

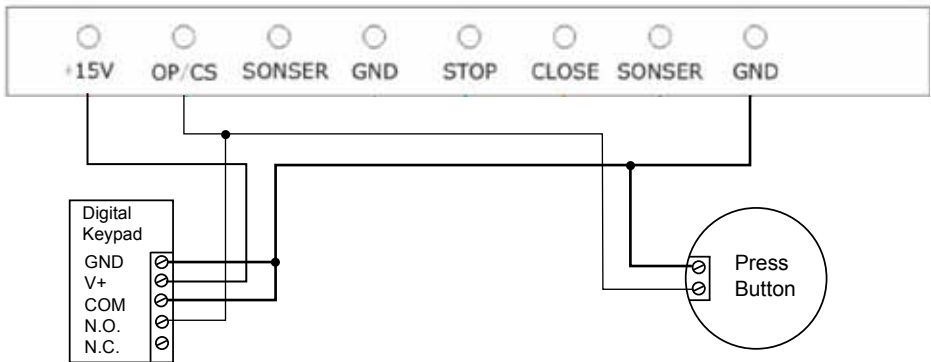

For Solar powered operators if a keypad is powered from the gate operator extra solar panels and batteries are required to allow for extra current draw.

STEP 5 - ACTIVATING THE REMOTE CONTROLS

Press the “F” button until “FF” appears on the display flashing, then release the “F” button and press any button on the remote control until the “FF” stops flashing and the remote control is activated.



You can activate up to 50 remote controls

Once activated the remote control has on button to open, one to close, one to stop and one for pedestrian entry that opens the gate only part way for pedestrians.



433MHZ Remote control

DEACTIVATING REMOTE CONTROLS

Press the “Enter” button until the display lights up, which takes about 1 second then all remote controls have been deactivated.

You can't deactivate them one at a time only all at once.

STEP 6 - SETTING THE OPEN AND CLOSE LIMIT

There are two magnets to be fitted to the rack, which set the open and close limits of the gate. The height of the magnet determines whether it is for open or close.

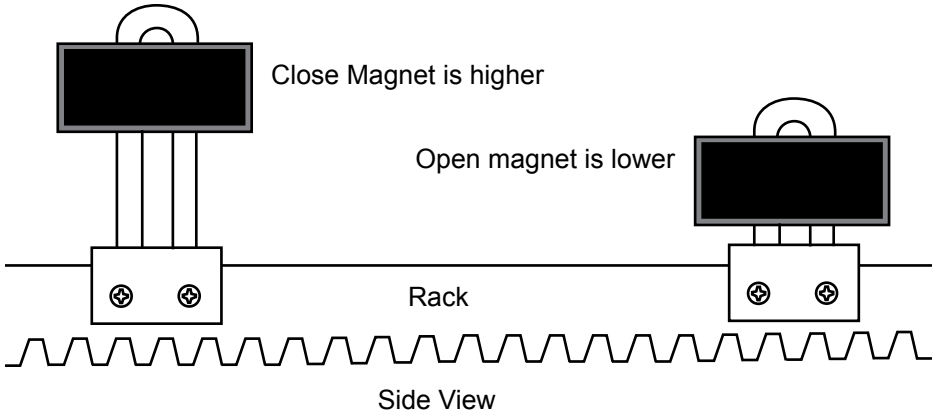

Fit the open magnet to the close end of the gate so it lines up with the sensor inside the SD Operator when the gate is opened. Then repeat the same with the close magnet on the open end of the gate.

Once the ramp down positions are set (next step) you may find the gate doesn't open or close enough. You can correct this by moving the position of the magnet and you may need to reset the ramp down positions after you have done this.

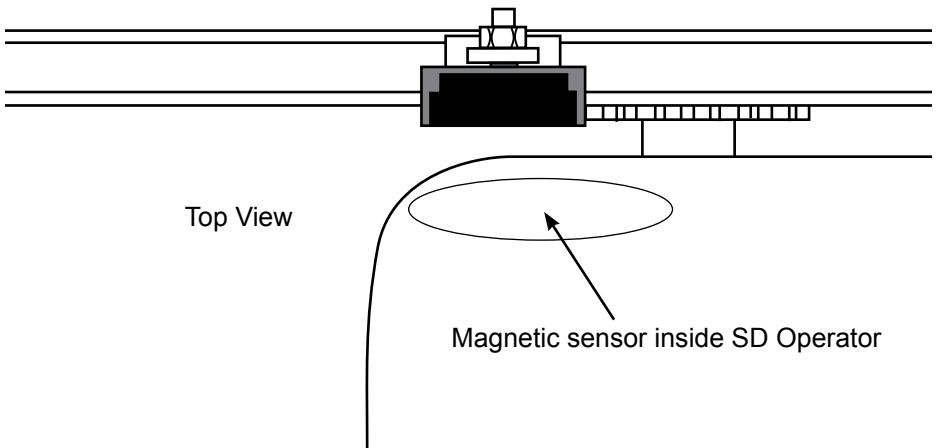

STEP 7 - SET THE OPEN AND CLOSE DISTANCE

Close the gate fully and press the “+” button on the circuit board in the SD Operator until “FF” appears on the display flashing, then release the “F” button. Now on a remote control press the “P” button followed by the “Open” button together holding them both until the gate begins to open slowly, then let go of the buttons. The gate will run until it reaches the open magnet so it learns the distance it has to travel. It needs to know this so it can ramp the speed down when normally opening.



Repeat the same using the “Close” button to set the close distance. The operator should now ramp up to full speed when opened and slow down as it approaches the fully open position and do the same when closing.



433MHZ Remote control

STEP 8 - MAKING OTHER CHANGES

If you press the “F” button “A0” appears on the display and you can use the “+” and “-” buttons to cycle through different options labelled A1 to A8, B0 to B2, C0 to C9 which are as follow:

Function debug form

Item	No#	Description	Setting Range	Remark
Motor	A0	Automatic stop/reverse force sensitivity during low speed	0-99	Default : 10 / Lower value means higher sensitivity
	A1	Automatic stop/reverse force sensitivity during fast speed	0-99	Default : 20 / Lower value means higher sensitivity 99=cancel
	A2	Motor rotation circle/ distance Setting when opening gate	0-99	Default : 67 decimal/ unit digits (LED)
	A3	Motor rotation circle/ distance Setting when opening gate	0-99	Default : 07 kilo/ hundreds digits (LED)
	A4	Motor rotation circle/ distance Setting when closing gate	0-99	Default : 67 decimal/ unit digits (LED)
	A5	Motor rotation circle/ distance Setting when closing gate	0-99	Default : 07 kilo/ hundreds digits (LED)
	A6	Force Setting for low speed	0-99	Default : 30
	A7	Force Setting for fast speed	0-99	Default : 99
	A8	Deceleration distance setting when opening gate	0-99	Default : 40
	A9	Deceleration distance setting when closing gate	0-99	Default : 40
	B0	Force Setting for Pedestrian opening speed	0-99	Default : 60
Function parameter	B1	Remote control operating (Push Button)	0- 2	0=Normal Operation 1=Delay 2 seconds to start the operation 2=First press stop button then close/ open button
	B2	Initial Self distance learning - fast start	0- 1	0=low speed learning 1=fast speed learning when push open button
	C0	Actual Display of A2 and A4 setting		Display decimal/ unit digit when Motor Start
	C1	Actual Display of A3 and A5 setting		Display kilo/ hundreds digit when Motor Start
	C2	Alarm Setting	0- 1	0=cancel 1: Armed when gate closed
	C3	Automatic Closing	0-99	0=cancel (1-99)=delay 1-99 seconds
	C4	Automatic Closing when pedestrian opening	0-99	0=cancel (1-99)=delay 1-99 seconds
	C5	Pedestrian Opening Distance Setting	0-99%	Default : 30%
	C6	Full Speed Opening Setting	0- 1	0=Linear acceleration start(soft start) 1=full speed start
	C7	LDR (light dependent resistors) Setting **	0-99	0=cancel 1-99= LDR Sensitivity Setting
	C8	Battery capacity display	0-99	Percentage Display, 99=fully charged
	C9	Reserved Function		

* Remark:C0 & C1 means the number of rotation of motor shaft
For example, if C0 display "52", C1 display "12", that means the motor rotates 1252 rotations

Pressing the “F” button again to select the option and use the “+” and “-” Buttons to change the option value.

INSTALLING THE SOLAR PANEL

For SD-SOL charging the battery is by way of one or more solar panels. It is important to place the solar panel where it gets full sun for as long as possible. You can install the solar panel away from the gate if you wish to get more sun and run low voltage cable back to the gate.

The solar panel(s) come with a mounting bracket, you must install this first by measuring half way along both sides of the solar panel and mark the hole positions for each bracket. Then drill holes for the two angle brackets being very careful NOT to drill into the glass of the solar panel. Place something in behind to prevent this from happening. Assemble the mounting bracket and then attach it to your post or wall.



BATTERY MAINTENANCE

The Battery should last from 3 to 5 years with normal use or less if it is allowed to run flat.

You can replace the batteries your self by opening the battery box and unplug them taking note of how they are connected. You can get replacement batteries from battery shops, alarm suppliers, electronics shops and autotmotive accesory shops.

WHAT HAPPENS IF THERE IS A POWER CUT?

Battery operated versions will not be effected by a power cut unless it is longer than a few days. If longer than this the gate should be manually operated and battery disconnected before it runs flat. Once the power is restored the battery will recharge. If the battery has been run flat allow over night charging before using.

When power is first restored if the gate is fully open or closed it will work normally but if power was lost while it was in mid cycle or it was manually released and left in mid cycle when powered up then once the gate is operated it will run at a slow speed until it finds the open or close magnet. While it is running at slow speed if you hold the open or close remote control button down the gate will ramp up to full speed and if you release the button it will ramp down to slow speed again, which is a feature purely for speeding up the process.

ACCESSORIES

TX-4	Extra Remote Controls for either 433.92Mhz (Blue) or 315Mhz (White)
RX-1	Stand alone Receiver - to allow a garage door or another brand of gate operator to be operated with the e-Gate remote control ether 433.92Mhz or 315Mhz.
RX-Mega	Stand alone receiver for a large number of users allows use of up to 1000 remote controls. A remote control can be deleted even if lost.
ANT-1	Antenna for remote control ether 433.92Mhz or 315Mhz.
Batt-TX	Replacement Battery for TX-4 Remote control
Batt-7Ah	Replacement Battery for Battery Back up (two required for 24V)
VCB-12	Voltage Converter Board 16 to 24VAC/DC in and 12V 500mA out
RLY-12	Relay Board 12VAC/DC in and clean contacts rated at 60VDC/125AC 2A
RLY-24	Relay Board 24VAC/DC in and clean contacts rated at 60VDC/125AC 2A
PC-1	Photocell 12/24VAC/DC 15m outdoor

TROUBLE SHOOTING

Gate runs in the wrong direction - check the motor power wires are correct, if wired the wrong way around the motor will travel in the wrong direction.

Gate runs for a short distance then stops - check the motor encoder wiring or operator isn't being overloaded by a stiff gate.

Operator not working at all - check power cord or battery cable is plugged in. Check there is power at the gate. Check fuses on the control board.

Gate won't work when first powered up - check the input cable connections are correct and all accessories that may be connected are working properly.

Remote control range drops some times - most likely caused by interference from some other device in the area using a similar frequency. Installing an external antenna can minimize the effects of interference.

WARRANTY

A 2 Year Back to Base Warranty is offered by Grant's Automation for any defect in a Gate Operator System manufactured by Grant's Automation or any third party component supplier to Grant's Automation due to faulty workmanship or materials causing the Operator to fail to work as specified in this Installation Manual.

Should any fault occur during the first 2 Years after the operator was purchased, it should be returned to the factory for repair or at the discretion of Grant's Automation replacement at no charge under the following conditions:

1. Proof of purchase is required ie. Invoice or purchase details recorded by Grant's Automation.
2. If an operator is not installed immediately after purchase, at the discretion of Grant's Automation, the warranty may be extended to up to a maximum of 2 Years after the date installed.
3. The operator has been installed according to this Installation Manual and Serviced according to the User Manual.
4. The operator has not been used for a gate larger, of a different type or higher frequency of use than that specified in this Installation Manual. All gate specifications are required before any claims will be accepted.
5. The operator hasn't been used in a highly corrosive environment or has been exposed to contaminants that could cause the operator to fail.
6. The operator has not been used for purposes other that it was intended for.
7. The operator has not been tampered with or modified by any party not authorised in writing by Grant's Automation to do so.
8. The operator has not been damaged by any malicious act, accident, animal infestation or adverse weather conditions beyond the control of Grant's Automation.
9. A reasonable amount of care with handling or using the operator has been be taken.