



INSTALLATION MANUAL

Braemar Ecostar TH3, TH4 and TH5 Gas Ducted Heater



THIS HEATER IS TO BE INSTALLED BY AN AUTHORISED PERSON ONLY

- DO NOT** Operate this appliance before reading the instruction booklet.
- DO NOT** Place articles on or against this appliance.
- DO NOT** Use or store flammable materials near this appliance.
- DO NOT** Operate this appliance with panels, covers or guards removed.
- DO NOT** Spray aerosols in the vicinity of this appliance while it is in operation.

This Braemar gas ducted heater must be installed in accordance with these instructions, local gas fitting regulations, municipal building codes, electrical wiring regulations, Australian Standard AS/NZS 5601 Gas Installations and any other relevant statutory requirements.

This heater must not be installed downstream from an evaporative cooler, air washer or indoor unit of a refrigerated system. This heater is not suitable for installation in a marine environment.

For external installations, ensure that the heater is located to maintain the minimum flue clearances as specified below and in AS/NZS 5601. Measurement is taken from the edges of the flue terminal.

- GAS TYPE:** Refer label alongside gas inlet.
- GAS CONSUMPTION:** Refer data label on underside of appliance lid.

UNPACKING THE HEATER

Remove the plastic wrap and cardboard transport cover. Check that the heater model and gas type is as required - model details are provided on the specification label on the end panel of the heater, gas type is given on the label next to the gas inlet. Report any transit damage within 7 days - Do not install the heater if it is damaged.

SAFETY INSTRUCTIONS

Employers and Employees Responsibility

The installation and maintenance of gas ducted heating units, particularly at height, has the potential to create Occupational Health and Safety issues for those involved. Installers are advised to ensure they are familiar with relevant State and Federal legislation, such as Acts, Regulations, approved Codes of Practice and Australian Standards, which offer practical guidance on these health and safety issues. Compliance with these regulations will require appropriate work practices, equipment, training and qualification of workers. Seeley International provides the following information as a guide to contractors and employees to assist in minimising risk.

Risk Assessment

A risk assessment of all hazardous tasks is required under legislation. A risk assessment is an essential element that should be conducted before the commencement of work, to identify and eliminate the risk of falls and other risks, or to minimise these risks by implementing control measures. This does not need to be a complicated process - it is a matter of assessing the job to be done and considering what actions are necessary so the person doing the job does not injure themselves.

This should be considered in terms of:

- What are the chances of an incident occurring?
- What could the possible consequences be?
- What can be done to reduce, or better still, eliminate the risk?

Some points to consider

Some points to consider when working on or in a roof

- What is the best and safest access to the roof and working areas?
- What condition is the roof in? Should the roof structure and surface be checked?
- Does the worker have appropriate footwear?
- Are all power cables/extension leads safe and appropriately rated?
- Are all ladders, tools and equipment suitable and in good condition?
- Where ladders are to be used, is there a firm, stable base for them to stand on? Can they be tied or secured in some way at the top?
- Is there a roof anchor to attach a harness and lanyard to? If so, instruction should be issued for the use of an approved harness or only suitably trained people used.
- Are all tools and materials being used, prevented from slipping and falling onto a person at ground level? Is the area below the work area suitably protected to prevent people entering this area?
- Does the work schedule take into account weather conditions, allowing for work to be suspended in high winds, thunder storms/lightning or other types of weather giving wet, slippery surfaces?
- Is there an on-going safety check system of harnesses, ropes, ladders and access/lifting equipment, and any anchor points on roofs before the commencement of work?
- Is there a system which prevents employees from working on or in roofs if they are unwell or under the influence of drugs or alcohol?
- Are there any special conditions to consider i.e. excessive roof pitch, limited ground area, fragile roof, electrical power lines?

HEATER LOCATION

Avoid quiet areas:

- Directly above, below or outside bedrooms, living room, lounge room, dining room etc.

Preferred installation locations

- Above, below or outside laundry, bathroom, kitchen, garage etc'

HEATER CONFIGURATION

Swapping inlet & outlet panels

The heater side panels can be moved to suit a range of installations. To do this:

- Remove heater top panel.
- Remove the screws securing the side/end panels that are to be changed.
- Remove the side panels.
- Move the inner metal insulation panel to the side or end of the heater to ensure a twin skin sheetmetal layer is maintained.
- Secure the side panels in their required new positions and re-fit the heater lid.
- Check that all panels are secure and that screws are tight.
- **IMPORTANT:** Increase the diameter of the air inlet spigot and the full run of inlet duct by 50mm to maintain the original air flow rate if it is moved from the open side to the motor side of the room fan.
- **IMPORTANT:** The air inlet panel must be fitted to the side of the heater - do not fit the air inlet panel to the end of the heater.

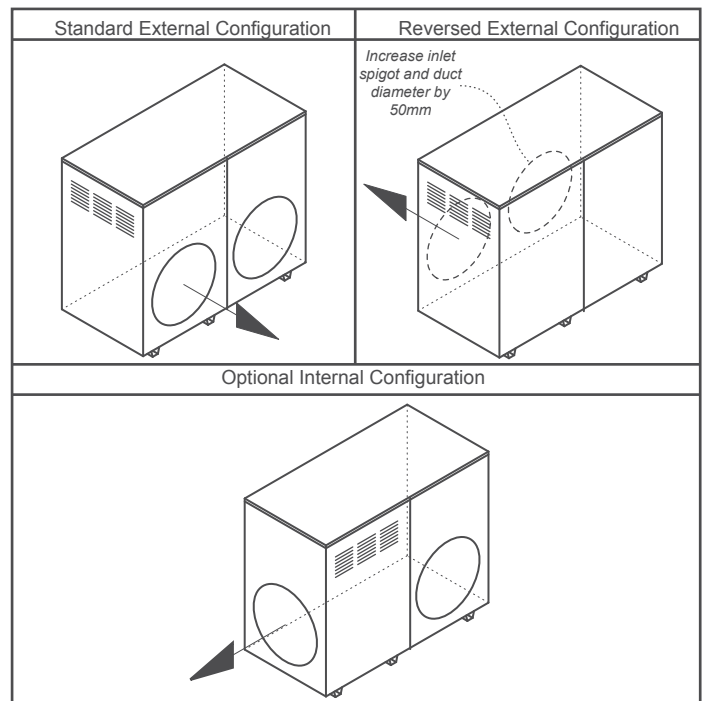

SPLITTING AND RE-CONNECTING THE HEATER

All TH series heaters can be split in two (remove fan box) to assist in lifting heaters into ceilings and moving the heater into position:

Splitting the heater

- Remove the heater top panel.
- Disconnect the wiring loom at the plug near the top of the centre panels.
- Disconnect the combustion fan suction hose from the pressure switch suction tappings (1 for TH3 models, 2 for TH4 & TH5 models) - use lower tapping/s.
- Disconnect the ignition lead and the white flame sense lead from the Fenwal ignition pack and feed through the grommet in the centre panel.
- Remove the two retaining screws near the top of the centre panels from the room fan end of the heater.
- Lift the room fan end of the heater to disengage from the locating tabs near the bottom of the centre panel.
- Separate the two halves of the heater.

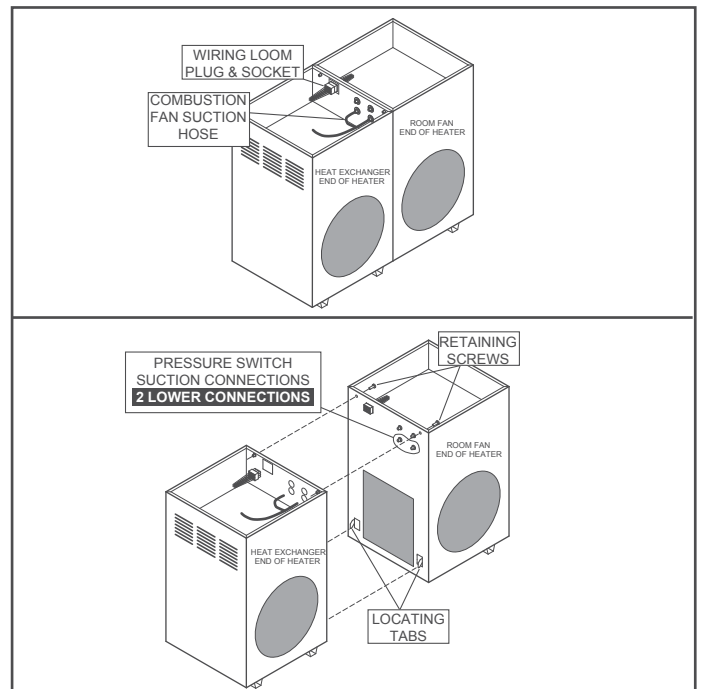

Re-connecting the heater

- Hook locating tabs into slots near bottom of centre panel.
- Re-fit 2 retaining screws near top of centre panel.
- Re-connect the combustion fan suction hose onto the pressure switch suction tappings (1 for TH3 models, 2 for TH4 & TH5 models) - use lower tapping/s.
- Re-connect wiring loom plug into socket.
- Re-connect the ignition lead and flame sense lead to Fenwal ignition pack.
- Re-fit heater top panel.

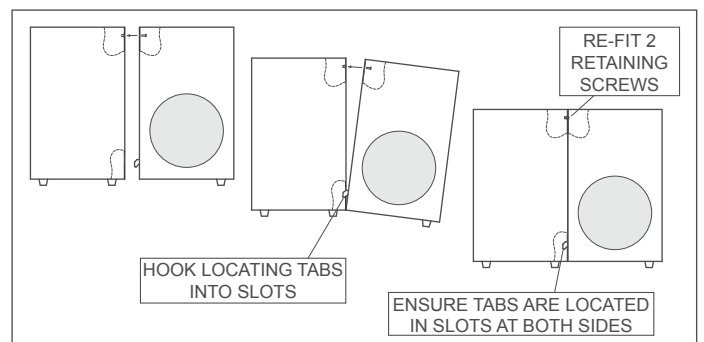

TEST THE HEATER ONCE RE-CONNECTION HAS BEEN COMPLETED

Reversing combustion flue outlet TH3/4

1. Remove side panels from combustion fan end of heater.

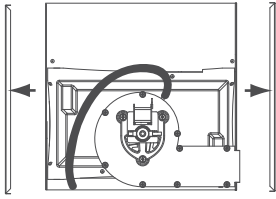

2. Twist combustion fan towards burners, lift fan up to separate from heater.

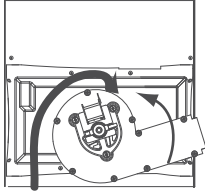

3. Turn combustion fan 180 degrees. locate fan feet in 4 round holes in flue pan twisting combustion fan towards burners to lock.

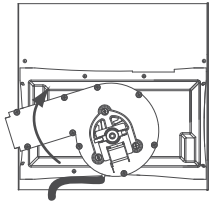

4. Fit side panels back to heater.

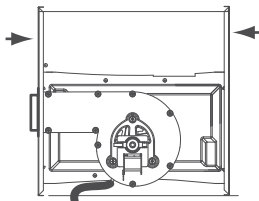

Reversing combustion flue outlet TH5

1. Disconnect flue fan extension from combustion fan. Remove flue outlet cover from opposite side of heater.

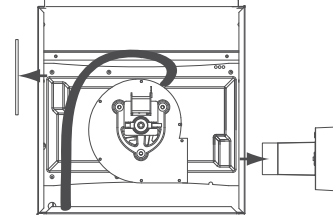

2. Twist combustion fan towards burners, lift fan up to separate from heater.

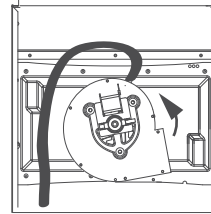

3. Turn combustion fan 180 degrees. locate fan feet in 4 round holes in flue pan twisting combustion fan towards burners to lock.

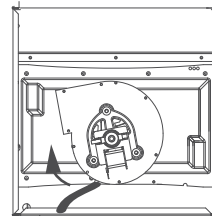

4. Reconnect flue fan extension using silicon to seal connection. Secure flue outlet to side panel using screws previously removed. Fit flue outlet cover to the original outlet hole.

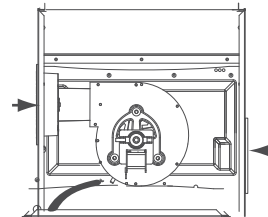

ADD-ON REFRIGERATED COOLING

TH Extra Air heaters are designed for use with an add-on refrigerated cooling system - these models include an "X" in their model numbers, eg, TH3X20, TH4X30 and TH5X32. The following points must be taken into account to ensure correct operation of both the refrigerated cooler and the heater.

- Ensure that the refrigerated cooling unit is sized correctly to suit the house and the heater.
- The cooling coil (evaporator) should be installed 1.5 to 2.5m from the heater supply air outlet.
- To prevent excessive air flow restriction, the ducting between the heater and the cooling coil should be as straight as possible. If bends are required, use the largest bend radius possible.
- A correctly-sized return air grille with a filter **MUST** be fitted when installing add-on refrigerated cooling.
- The thermistor must be located after the cooling coil 3m along the duct from the heater outlet, and fitted centrally in the top of the duct.

The "A/C" terminals on the BSC coircuit board in the heater supply 24Vac control voltage to operate the cooling system. The preferred connection from the heater is via a 24Vac relay to switch the cooling system on and off - this is not supplied by Braemar.

Ensure that "COOL 2" is selected during system set-up to enable the system to operate the refrigerated cooling system - refer to "Commissioning" section in these instructions.

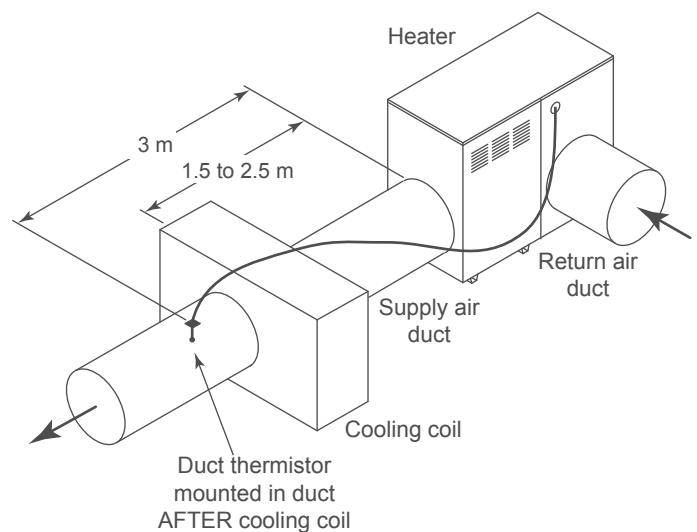

GOOD DUCTING GUIDLINES

Correct ductwork installation is critical to ensure correct operation of the heating system, and to prevent premature failure of the fan and/or heat exchanger. The following must be considered:

Supply and return air ducting

- Ductwork should be adequately sized to suit the heater and installation to prevent excessive system back pressure.
- Duct run > 6m, increase the diameter of the spigot and duct for the full length of the duct run by 50mm.
- Duct run > 9m, increase the diameter of the spigot and duct for the full length of the duct run by 100mm.
- Ductwork should be adequately supported and free from air leaks.
- Volume dampers are recommended to enable proper balancing of the system.
- Bends in ducting must be as smooth as possible to minimise restriction to air flow, recommended MINIMUM bend radii are:
 - 150 to 300 mm duct 1.5 duct diameters
 - 350 to 400 mm duct 2 duct diameters
- The minimum RETURN AIR DUCT length should be 3m, and should include a bend to help reduce noise transmission along the duct.

Outlet registers

- At least one outlet register must be provided in all areas to be heated.
- Care should be taken to prevent cold spots, due to excessive draught or insufficient outlets.
- The normal position of furniture in the home must be considered when locating registers.
- The type of register should be selected to suit the application:
 - Registers installed in the floor should discharge sideways.
 - Registers installed in the ceiling should discharge predominantly vertically.

Outlet Chart ^[1]

Model (kW)	Recommended Minimum & Maximum system installed outlets			
	Ceiling		Underfloor	
	TH3	TH4/TH5	TH3	TH4/TH5
15/16	5-8	5-8	6-11	6-11
20/23	6-11	6-11	8-14	8-14
25 (TH3/4 only)	8-13	8-13	10-17	10-17
30/32	10-16	10-16	13-21	13-21
35 (TH4 only)	NA	11-18	NA	14-23
20X/23X ^[4]	7-12	7-12	9-15	9-15
25X (TH3/4 only ^[4])	8-14	8-14	11-18	11-18
30X/32X ^[4]	11-18	11-18	14-23	14-23

Model (kW)	Minimum outlets installed per zone ^[2]	
	Ceiling	Underfloor
	TH4/TH5	TH4/TH5
15/16	1	2
20/23	2	3
25 (TH3/4 only)	2	3
30/32	3	4
35 (TH4 only)	3	4
20X/23X ^[3]	2	3
25X (TH3/4 only ^[3])	2	3
30X/32X ^[3]	3	4

1. Based on standard 100 x 300mm floor outlets and 150mm round ceiling outlets.
2. Minimum outlets open to achieve optimum turndown performance.
3. 'X' in model refers to extra-air models - maximum outlets will be reduced when a cooling coil is installed.

Additional notes:

- A minimum of one outlet must remain fully open at all times while the heater is in operation - possible increased noise should be considered if outlets are closed manually.
- Where a common zone is installed in a multi-SCC zoned system, it can have one or more outlets, and should be located near the return air grille.

Return air grille location

- Heaters are **not** suitable for outside return air.
- Always locate the return air grille in a suitably heated area, central hallways are usually the most suitable.
- Do not locate in a bathroom or laundry as the moisture present in these rooms may settle on the fan when not in use.
- The return air grille should be located so that it is unobstructed by carpets, clothing, furniture.
- Air should not be drawn through areas that are not heated.
- It is recommended that the return air grille is located at a low level - system performance may be reduced if a high level return air grille is used. N.B Not Recommended above 2.7m.
- In a single SCC zoned system, the return air grille must be located in the "common" zone, ie, in a zone that cannot be turned off.
- In a multiple SCC zoned system, where there is no common zone the return air grille must be located centrally.

Return air grille sizing

Model (kW) TH3-TH4-TH5	Minimum grille dimensions (mm)		Duct connection diameter (mm)
	No filter	With filter	
15/16/20/23	500 x 400	750 x 400	300
25	600 x 400	900 x 400	350
30/32	750 x 400	1000 x 400	350
35	900 x 400	1200 x 400	400
20X/23X	600 x 400	900 x 400	350
25X	750 x 400	1000 x 400	350
30X/32X	900 x 400	1200 x 400	400

- Equivalent grille sizes may be used.
- Fitting a filter is recommended.
- A filter may generate some air flow noise - the owner should be advised.
- The owner should be advised to clean the filter every two weeks and replace annually.

ZONING - TH4 & TH5

TH4 and TH5 model heaters can be installed and set-up to independently heat different areas within the home either from a single Spectrolink Comfort Control (SCC) or from up to four independent SCCs. In each case zone dampers must be installed into selected duct runs to allow the air flow to a zone/s to be turned on or off.

1 SCC Thermostat:

Each zone is controlled independently from a single SCC. The SCC must be located in a "common zone", ie, a zone that cannot be turned off, and that includes the return air.

Multiple SCC thermostats:

Each zone is controlled independently from its own SCC - this allows zones to be set at different temperatures, and to be controlled from within the zone. Each zone that has its own SCC thermostat must include a zone damper.

Hints for zoned systems

- Talk to the customer to get an understanding of their requirements.
- Allow for an outlet near the return air to prevent drafts and cold spots.
- For 1-SCC systems ensure that the COMMON zone is always heated, even if it is only a small air flow. The common zone must include a return air grille.
- Explain to the customer the function of the return air duct, and the need for a clear air path to the return air grille - air cannot travel through closed doors.
- For 1-SCC systems position the wall control in the COMMON zone.
- DO NOT in any way obstruct the flow of return air.

Zone fan speeds

- Zone fan speeds must be set to ensure an appropriate air flow for each zone. If the fan speed is set too high for the number of outlets this may cause high air flow noise and will not be covered under warranty.

Kits and parts required for zoning

- **24V zone kit P/No 077215** - to suit 24Vac zone dampers: Kit includes - zone connection PCB, communication loom, 24Vac transformer.
- **240V zone kit P/No 077208** - to suit 240Vac zone dampers: Kit includes - zone connection PCB, communication loom, PCB connection wires.
- **Multiple SCC's** - one SCC is supplied with each 4 & 5 star installation accessories kit - an additional SCC & loom is required for each additional zone - **SCC/loom kit P/No 076010**.
- **Zone dampers** and suitable wiring (not supplied by Seeley International)

CLEARANCES AND CONNECTIONS

Minimum flue clearances for external heaters

75mm

- From a drain pipe or soil pipe.

300mm

- From any other flue terminal, cowl, or combustion air intake.
- Below eaves, balconies, and other projections.
- Horizontally from an openable window, door, non-mechanical air inlet, or any other opening into a building with the exception of sub-floor ventilation.

500mm

- From electricity meter or fuse box.
- From a return wall or external corner.
- Horizontally from any building structure or obstruction facing a terminal.

1000mm

- From a gas meter.
- From a mechanical air inlet, including a spa blower.
- Vertically below an openable window, non-mechanical air inlet, or any other opening into a building with the exception of sub-floor ventilation.

1500mm

- Horizontally in the direction of discharge from an openable window, door, non-mechanical air inlet, or any other opening into a building with the exception of sub-floor ventilation.

Refer also: AS/NZS 5601 Gas Installations

GAS CONNECTION

- All gas supply piping must be installed by a licensed gas fitter in accordance with Standard AS/NZS 5601 Gas Installations.
- Gas connection point: All models - 3/4" BSP female flare nut.
- Gas supply piping must be sized to ensure a minimum gas pressure of 1.13 kPa for natural gas appliances or 2.75 kPa for propane appliances at the inlet to the heater with the heater and all other gas appliances operating at maximum gas rate. Detailed pipe sizing information is contained in Standard AS/NZS 5601 Gas Installations.
- The maximum gas rate for the heater is located on the specification label on the underside of the heater lid.
- An AGA approved gas cock/manual shut-off valve must be fitted in the gas supply line adjacent to the heater (outside the heater cabinet) to enable isolation of the heater for maintenance and/or servicing.
- Ensure that all air is purged out of the gas line.
- Ensure that there are no gas leaks.

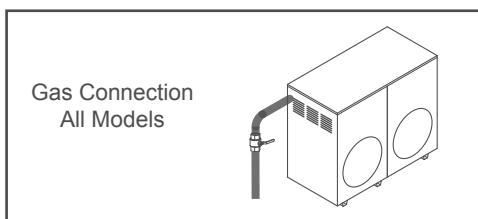

ELECTRICAL CONNECTION

- Electrical wiring & fittings must be installed by a licensed Electrician.
- Seeley International recommends that all Braemar gas ducted heaters are wired with a dedicated circuit from the distribution board with a separate circuit breaker.
- Wiring must be installed in accordance with the relevant electrical standards & regulations.
- The electrical supply must be 240V 50Hz.
- A conventional 10A 3-pin 240V GPO must be fitted adjacent to the heater.
- Ensure that the polarity of the power supply is correct.

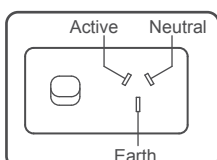

IMPORTANT
ENSURE THAT POLARITY OF
POWER SUPPLY IS CORRECT

THERMOSTAT LOCATION

In a single wall control installation the wall control should be located central to the main living area approximately 1.5m above floor level. The main living area should be confirmed with the occupants.

In a multiple SCC installation each SCC must be located in the zone that it controls.

Wall control placement is critical to ensure correct functioning of the heating system. The following points must be taken into account:

- Avoid direct sunlight.
- Avoid mounting on external walls.
- Avoid mounting near heat sources such as stoves, TV sets etc
- Do not locate in the air stream from an outlet register.
- Do not locate in draughty areas.
- Do not locate in hallways.
- Do not locate adjacent to return air grille.
- Always fill cable entry hole in wall.

Braemar Spectrolink Comfort Control (SCC)

- The Braemar Spectrolink Comfort Control (SCC) is required to obtain full functionality with Braemar TH series heaters, including zoning (TH4/TH5 models) and evaporative or refrigerated cooler operation (TH3/TH4/TH5 models).
- With the addition of an optional zone kit, the TH4 and TH5 heaters can be used with up to 4 SCC's, with each thermostat controlling its own independent zone.

SCC Wiring

- A 20m loom is supplied with the heater for connection directly between the heater and the SCC.
- Plug the loom into the "CC" terminal on the BSC board in the heater.

Mounting the SCC

- Feed the wiring loom through the large hole in the SCC mounting bracket and attach the mounting bracket to the wall
- Plug the wiring loom into the socket on the SCC and carefully slide the SCC into the mounting bracket.

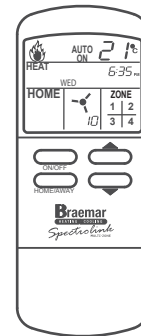

24V "Manual" Thermostat

All TH series heaters can all be used with a standard 2-wire type manual digital thermostat. Connect a low voltage 2-wire loom between the thermostat and "T/STAT" on the BSC circuit board. Note that with Braemar TH series heaters zoning and evaporative or refrigerated cooler operation is not possible with these thermostats.

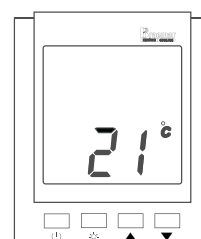

HEATER DIMENSIONS

Heater Model	Dimension (mm)															
	A	B	C	D	E	F	G	H	J	K	L	M	N	P	Q	R
TH3 and TH4 models																
TH315, TH415	385	660	570	20	770	200	385	685	395	250	300	555	330	700	625	55
TH320, TH420	385	660	570	20	770	200	385	685	395	250	300	555	330	700	625	55
TH325, TH425	385	660	570	20	770	200	385	735	415	250	350	555	330	700	625	55
TH330, TH430	510	660	555	20	880	200	415	765	415	240	350	555	330	700	625	80
TH435	510	660	555	20	880	200	415	765	415	240	400	555	330	700	625	80
TH3X20, TH4X20	385	660	570	20	770	200	385	735	415	250	350	555	330	700	625	55
TH3X25, TH4X25	385	660	570	20	770	200	385	735	415	250	350	555	330	700	625	55
TH3X30, TH4X30	510	660	555	20	880	200	415	765	415	240	400	555	330	700	625	80
TH5 models																
TH516	385	660	570	20	1150	535	775	1065	400	250	300	580	670	1000	625	55
TH523	385	660	570	20	1150	535	775	1065	400	250	300	580	670	1000	625	55
TH532	510	660	555	20	1165	525	705	1055	415	240	350	580	620	980	625	80
TH5X23	385	660	570	20	1150	535	775	1115	415	240	350	580	670	1000	625	55
TH5X32	510	660	555	20	1165	525	705	1055	415	240	400	580	620	980	625	80

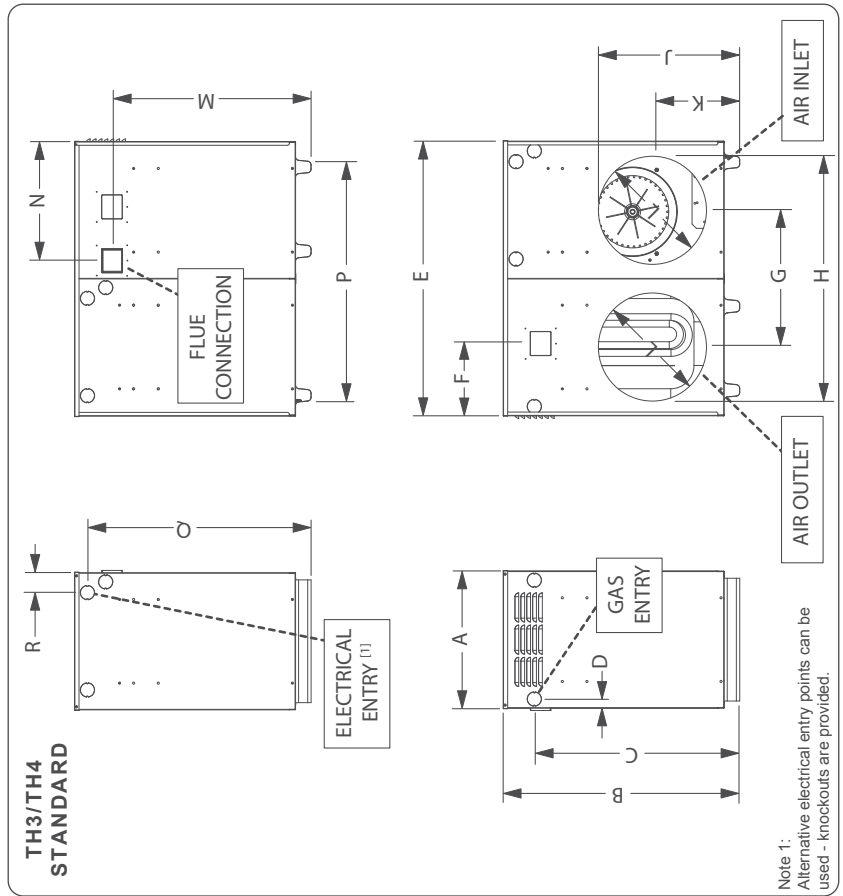
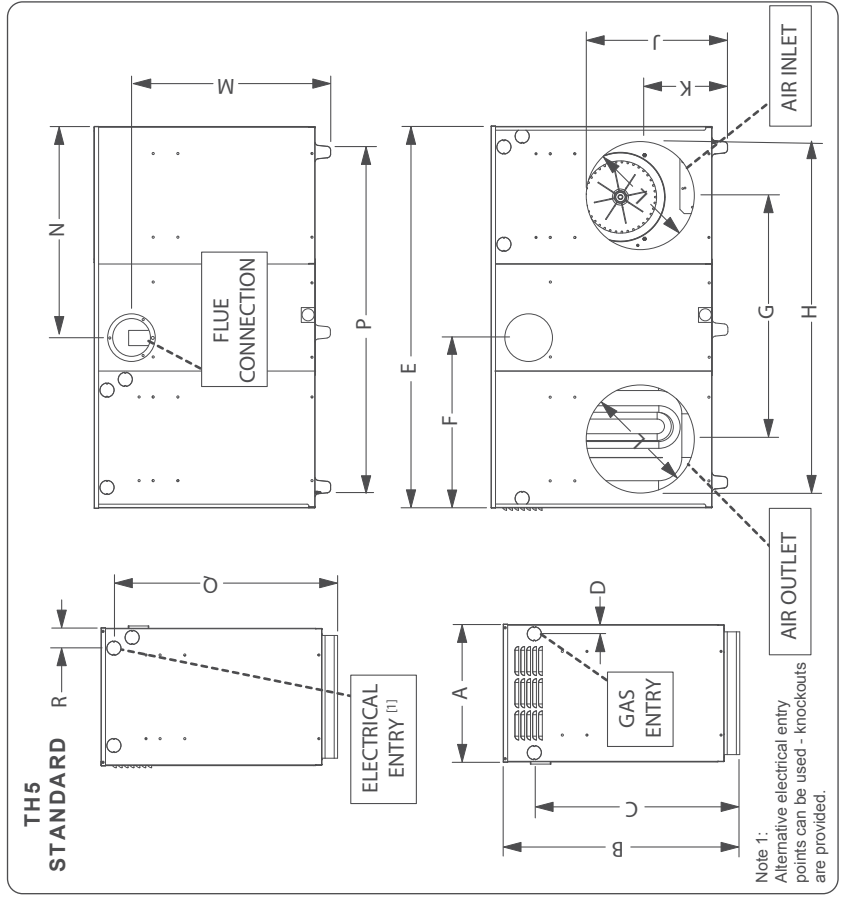

KITS

Installation kits

HEATER MODEL	INSTALLATION	THERMOSTAT	KIT PART No
TH3/4	Internal	Spectrolink (SCC)	075945
	External		075952
	Underfloor		077345
TH3	Internal	Manual Digital	077284
	External		077291
	Underfloor		077352
TH5	Internal/Underfloor	Spectrolink (SCC)	075983
	External		076041

Notes:

- TH3 & TH4 installation kits are also suitable for TG3 & TG4 model heaters.
- The Spectrolink Comfort Control thermostat is required to enable maximum heater functionality.

Zoning kits - 4 & 5 star heaters only

KIT DESCRIPTION	KIT PART No
24 Vac zone kit	077215
240 Vac zone kit	077208
Spectrolink comfort control thermostat (SCC) and cable	077314

Note:

- Zone dampers are not supplied by Seeley International and are not included in the above zone kits.

Miscellaneous kits

KIT DESCRIPTION	KIT PART No
Spectrolink comfort control (SCC) and cable	077314
Side wall heat shield kit (TH3/4)	077420
Flue guard kit	079073
TH5 flashing kit - flush to wall	076010
TH5 Small (TH516/TH523) flashing kit - 150mm	075990
TH5 Small (TH516/TH523) flashing kit - 300mm	076034
TH5 Large (TH532) flashing kit - 150mm	077260
TH5 Large (TH532) flashing kit - 300mm	077277
TH3/4 - 15/20/25 kW - flashing kit - flush to wall	076898
TH3/4 - 15/20/25 kW - flashing kit - 150mm	076331
TH3/4 - 15/20/25 kW - flashing kit - 300mm	076348
TH3/4 - 30/35 kW - flashing kit - flush to wall	076898
TH3/4 - 30/35 kW - flashing kit - 150mm	076362
TH3/4 - 30/35 kW - flashing kit - 300mm	076386
TH5 plenum box kit (small units only 16/23 kW)	076287

EXTERNAL INSTALLATION

Heater base

- Construct the heater base and prepare wall opening to the dimensions shown in the table below.
- **ENSURE THAT THE BASE IS LEVEL IN BOTH DIRECTIONS.**
- Heater is approved for installation against a wall.
- Refer to above kits tabel for flashing kit part numbers.

Heater Model	Dimension (mm)			
	Concrete slab		Wall opening	
	A	B	C	D
TH3 and TH4 models				
TH315, TH415	400	800	460	760
TH320, TH420	400	800	460	760
TH325, TH425	400	800	460	760
TH330, TH430	550	900	460	870
TH435	550	900	460	870
TH3X20, TH4X20	400	800	460	760
TH3X25, TH4X25	400	800	460	760
TH3X30, TH4X30	550	900	460	870
TH5 models				
TH516	400	1200	460	1160
TH523	400	1200	460	1160
TH532	550	1200	460	1160
TH5X23	400	1200	460	1160
TH5X32	550	1200	460	1160

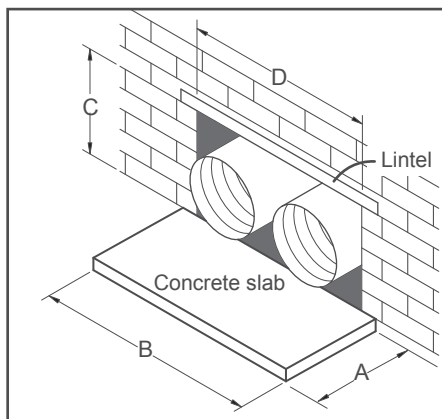

Flue connection - TH3 & TH4

- Attach powder coated die cast flue terminal to heater over flue outlet, fixing in place using screws supplied.

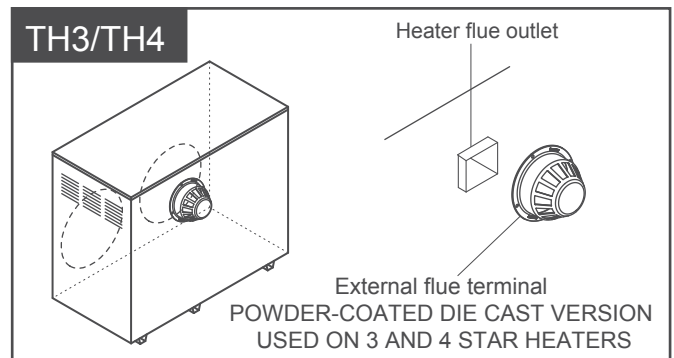

- Powder coated die cast flue terminal and starter collars are included in external installation accessories kit.
- Larger starter collars (400mm) required for the X30, X32 & 35kW units are supplied inside the heater fan inlet.
- Old style stainless steel external flue terminal is available as an option P/No 628967.
- A flue guard kit is available for external installations. P/No 079073.

Flue & condensate drain connection - TH5

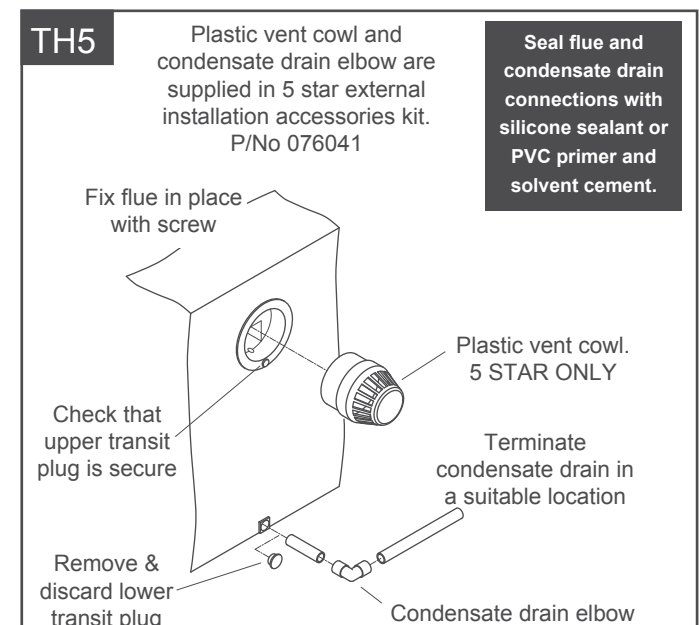

CEILING INSTALLATION

Heater platform and clearances

- The heater must be mounted on a platform to enable access for servicing and maintenance.
- Minimum clearances must be maintained around the heater as shown.
- A 600mm wide walkway must be provided from the ceiling access point to the appliance.
- Permanent artificial lighting must be provided at the appliance with the switch adjacent to the access opening.
- Check that the section of the roof in which the heater is to be installed is capable of supporting the additional load of the heater. Where possible, the heater should be mounted over a load-bearing wall so that it is not being supported by the ceiling joists alone.
- Check that the heater does not cause deformation of any part of the building structure.

Flue connection - TH3 & TH4

- This heater must be flued using AGA approved 100 mm metal flue pipe.
- External joins - socket must face downwards. Internal joins - socket must face upwards.
- Socket joins must be adequately sealed - eg, Silastic 747 silicone sealant.
- Twin-wall metal flue must be used for any part of the flue that is not readily accessible.
- Twin-wall metal flue is recommended for flue exceeding 2m in length.

Flue lengths:

- Maximum vertical: 4.8m
- Maximum horizontal: 4m
- Maximum total: 6m

Flue bends:

- Maximum 2 x 90° elbows
- 2 x 45° bends = 1 x 90° elbow

- 90° bend and starter collars are included in internal installation accessories kit.
- Larger starter collars (400mm) required for the X30, X32 & 35kW units are supplied inside the heater fan inlet.

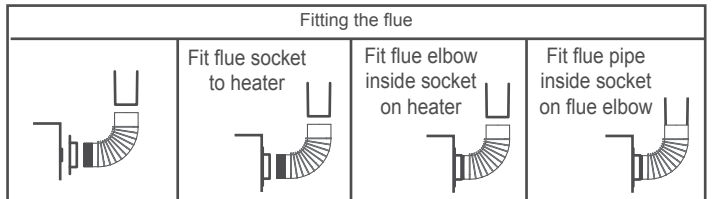
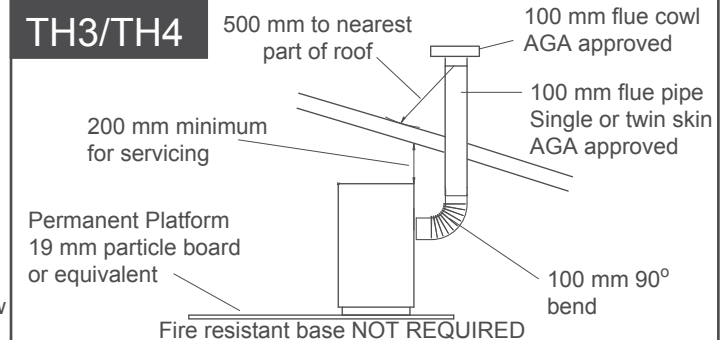
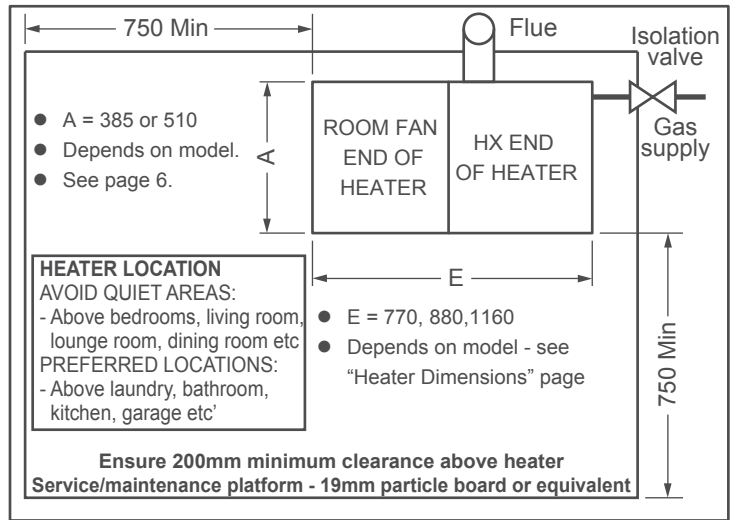

Flue & condensate drain connection - TH5

TH5

SEAL CONNECTIONS: Seal flue and condensate drain connections using silicone sealant or PVC primer and solvent cement.
INSULATE DRAIN LINE: Fit insulation (eg, Armaflex) over full length of condensate drain line in sub-zero climates

Condensate drain tee assembly:

The flexible tube supplied as part of the condensate drain tee assembly is intended to prevent excessive strain of the condensate drain fittings when fitting and securing the rigid PVC drain line. It is not designed to take the place of a 90° bend.

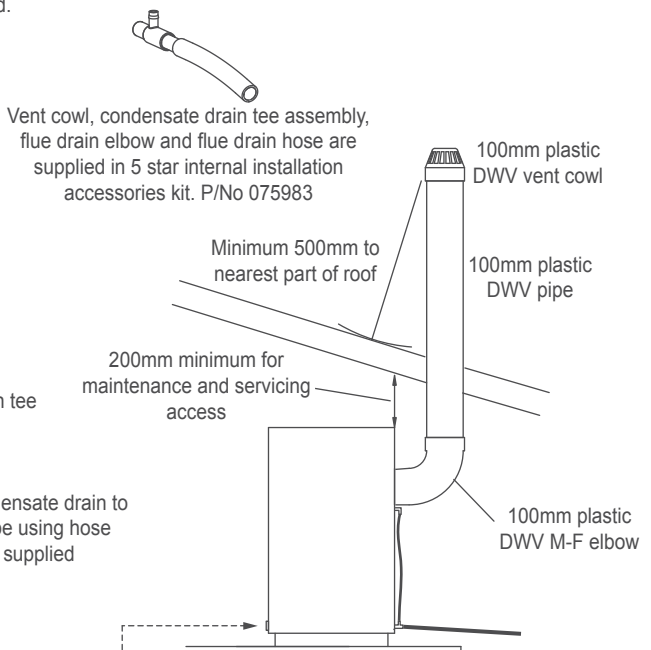
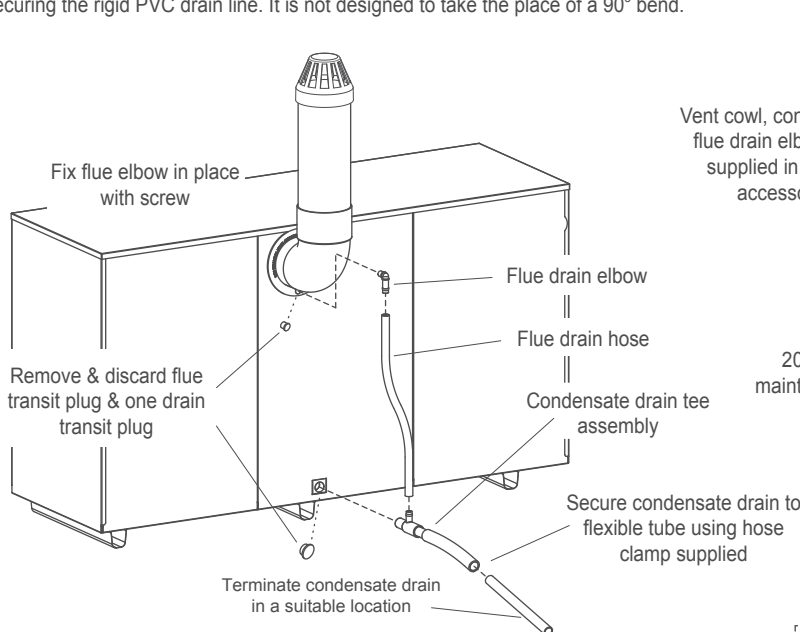

Seal remaining drain transit plug located on the opposite side of the heater to condensate drain using silicone sealant or PVC primer and solvent cement.

UNDER-FLOOR INSTALLATION

There is to be a minimum clearance of 200mm between the lowest part of the floor structure and any part of the heater.

- The heater is to be located within 2m of the access opening, or there is to be a minimum clearance of 1.2m between the lowest part of the floor structure and the ground level, maintained from the access opening to the appliance.
- The heater must be mounted on a level concrete base of at least 50mm thick as per the slab dimensions or suspended above the ground.
- Fixed artificial lighting must be provided at the heater, with the switch located adjacent to the access opening.

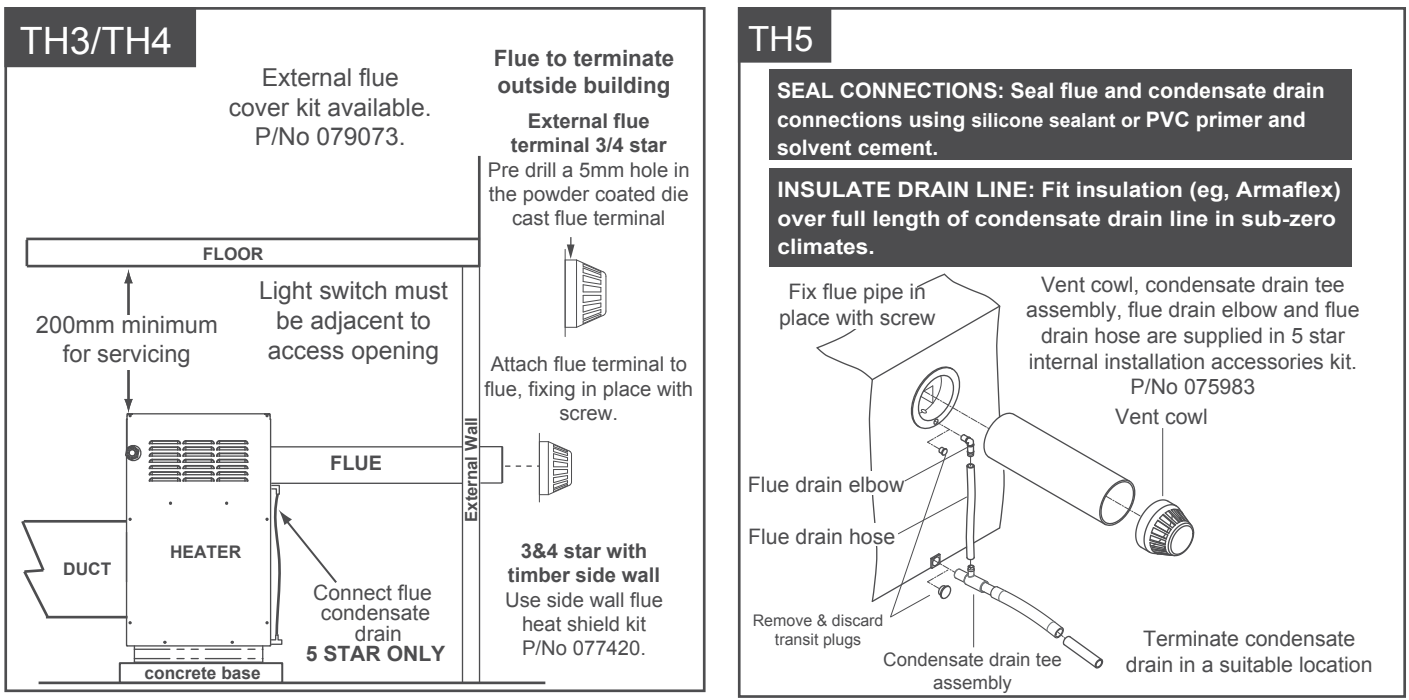

FLUE SYSTEM & CONDENSATE DRAIN TH5

Flue system

- Braemar TH5 heaters must be flued using 100mm DWV plastic pipe and components complying with AS1260.
- The flue terminal on the side of the heater is designed to accept either the male end of a 100mm DWV M-F elbow, or 100mm DWV pipe.

Connections

- **The connection to the heater, and all other joints in the flue and condensate drain system must be sealed to prevent leakage of condensate.**
- **USE SILICONE SEALANT OR PVC SOLVENT CEMENT AND PRIMER FOR ALL CONNECTIONS.**

Flue terminal

- The flue system must be terminated to outside with a 100mm DWV vent cowl as shown in the installation diagrams.
- This is supplied in both internal and external installation accessories kits.

Maximum flue length

- Maximum vertical rise : 5 metres,
- Maximum total flue length 12 metres,
- Maximum number of bends 4 x 90° (2 x 45° bends = 1 x 90°).

Condensate drain

- Use either 15mm rigid PVC pressure pipe or 20mm rigid PVC electrical conduit.
- Do not allow condensate to be discharged over electrical connections, earth stakes, concrete paths, copper pipes or metallic roofs. Do not discharge directly into guttering.
- Condensate can be discharged into a vent pipe via a tundish and self-sealing device, or into a vertical section of a downpipe via a tundish.
- Condensate drain must run down hill from connection point on heater to point of discharge - do not allow any part to run up-hill.
- Condensate drain must be well supported.
- Do not allow condensate to be discharged into any potable water system or potable water system collection point.
- Fit insulation (eg, Armaflex) over full length of condensate drain line in sub-zero climates.

INSTALLING THE DUCT THERMISTOR TH4 - TH5

Thermistor location is CRITICAL to the correct operation of the heater

- The outlet air temperature thermistor must be installed in the outlet air duct approximately 3 metres of duct length from the heater outlet.
- On systems with more than 1 outlet duct from the heater the thermistor must be located in the duct that always has air flow.

To Install the Thermistor

- Drill a 12 mm hole in the BTO or duct.
- Feed the thermistor and bracket through the grommet in the side of the heater.
- Insert the bracket into the hole in the BTO and screw into place.
- Seal the hole.
- Coil and secure any excess thermistor cable outside the heater.

COMMISSIONING - INSTALLER OR COMMISSIONING AGENT

Installation checks

- Check for gas leaks - rectify any leaks found.
- Check that the flue system is connected, sealed and installed with appropriate clearances.
- Check that thermostat is wired correctly and installed in a suitable location.
- Check that the heater is level in both directions (critical for 5 star heaters to allow correct drainage of condensate).

Gas pressure checks

- Connect a manometer to the outlet pressure test point on the gas valve.
- Start the heater.

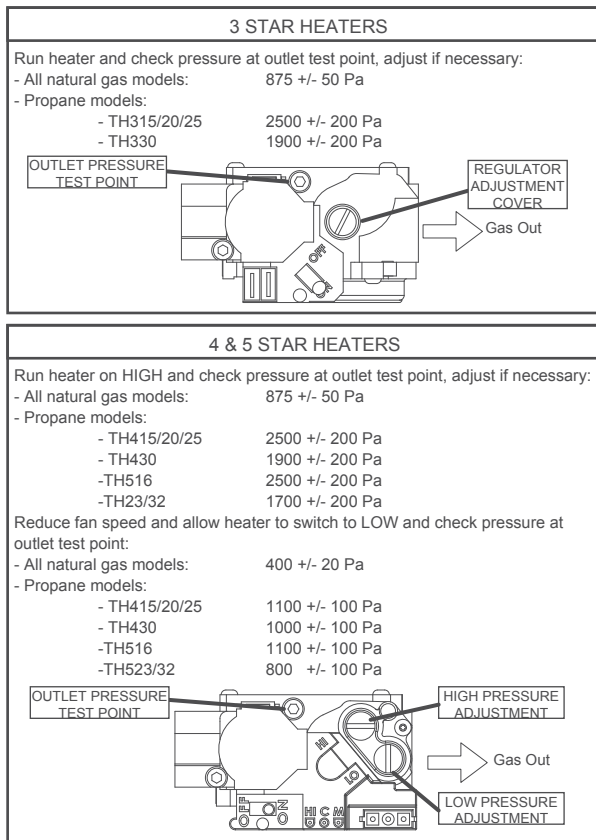

SYSTEM SETUP

Set the time and day (SCC thermostat)

- With the SCC in OFF mode, press and hold SET
- Use the UP/DOWN arrows to adjust the time, press SET when satisfied
- Use the UP/DOWN arrows to adjust the day, press SET when satisfied

Set the heater and cooler type (SCC thermostat)

- With the SCC in OFF mode, press SET & AC MODE simultaneously
- Use the UP/DOWN arrows to adjust to heater type to **HEAT 3 (factory default)**, press SET when satisfied
- Use the UP/DOWN arrows to adjust the cooler type, press SET when satisfied
 - **COOL 1 = evaporative (factory default)**
 - COOL 2 = refrigerated

Note that the above settings can only be adjusted within the 1st hour of powering the SCC. After that, disconnect the SCC loom, discharge the SCC capacitor then re-connect the loom.

Set maximum fan speed

3 Star heaters

- Turn the heater on at the thermostat and allow to run for 5-10 minutes to reach operating temperature.
- Check the air flow from all outlets.
- If required, adjust the fan speed by turning the trimpot located on the BSC board (alongside the 10 pin connector).
- Fully clockwise = fan speed 10
- Fully anti-clockwise (3/4 turn) = fan speed 7

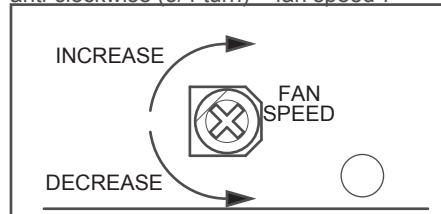

4 & 5 Star heaters

- Press and hold SET and press FAN.
- Check the air flow from all outlets.
- If required, adjust the fan speed (7, 8, 9 or 10) using the UP/DOWN arrows. Press SET when satisfied.

Enable installed zones (SCC thermostat, 4 & 5 star heaters only - not required where multiple SCC's are installed)

- With the SCC in OFF mode, press and hold SET and press ZONE 1
- Press the required zone buttons to enable installed zones
- Press SET when satisfied

Set zone fan speeds (SCC thermostat, 4 & 5 star heaters only)

- With the SCC in OFF mode, press and hold FAN and press ZONE 1
- Use the UP/DOWN arrows to adjust the fan speed for the common or flashing zone.
- Press SET to accept fan speed selected
- Repeat for all enabled zones

Balance the air flows

- With the heater running and all outlets open, adjust balancing dampers to achieve a suitable air flow from each outlet.

Programming the thermostat (SCC thermostat)

- Discuss auto program requirements with the customer
- To enter programming mode press and hold SET with the SCC in AUTO mode.
- Use the UP/DOWN arrows to adjust the day or group of days to be programmed then press SET - system goes to WAKE time period
- Adjust time, temperature, zones and fan speeds:
 - Use UP/DOWN arrows to adjust start time then press SET
 - Use UP/DOWN arrows to adjust required temperature then press SET
 - Use UP/DOWN arrows to select zones to be heated for time period then press SET
 - Use UP/DOWN arrows to adjust fan speed then press SET (this step is not required in multiple thermostat systems)
 - System will go to next time period
- Repeat setting procedure for AWAY, HOME and SLEEP time periods

Explain system operation to customer

- Explain the operation of the system to the customer/home owner
- Hand the operating instructions and warranty card to the customer/home owner.

TROUBLE SHOOTING & DIAGNOSTICS

If the heater fails to start, try the following:

No power.

- Is green LED on BSC circuit board on?
- Plug in heater supply lead
- Turn on power
- Turn on circuit breaker

No gas supply.

- Min' supply pressure
 - 1.13 kPa (NG)
 - 2.75 kPa (LPG)
- Has gas meter been installed?
- Turn gas on at gas meter

Thermostat not connected

- Connect "manual/2-wire" thermostat to "MAN T/STAT" terminals on circuit board
- Connect Braemar Spectrolink CC to "CC" terminals on circuit board

No thermostat communication.

- Check for "YES" on SCC display when first powered

Thermostat not calling for heat

- Adjust set point above current room temperature.
- Check LED's - centre LED (red) on steady

Combustion fan does not start

- Check that the fan is not blocked or jammed

No spark

- Check flue cowl is installed correctly
- Check wiring to pressure switch is not dislodged

Spark but no ignition

- Check gas valve on/off switch is set to ON
- Check flame roll-out switch is closed (press red button)

Room fan does not start

- Check room fan wiring connected correctly

Heater shuts down after 60 seconds

- Check that thermistor is in duct and located approximately 3m from heated air outlet (4/5 star only).

All checks OK but still does not start

- Disconnect power, wait 5 minutes and start again



Warranty Service
Australia 1-300-650-644
seeleyinternational.com

It is the policy of Seeley International to introduce continual product improvement. Accordingly, specifications are subject to change without notice. Please consult with your dealer to confirm the specifications of the model selected.

DIAGNOSTIC CODES

(SCC thermostat required - refer service manual for full instructions)

3 STAR HEATERS			
Code No	Description	Shut down type	SCC display
1	P-100 closed at start	L1	Reset, 1
2	P-100 failed to close	L1	Reset, 2
3	P-100 open during run	SSD	Normal
7	Ignition failure	L1	Reset, 7
9	Internal memory failure	L2	Reset, 9
* 10	HX OT1 opened	SSD/L1	Normal
11	EFS shutdown	SSD/L1	Normal
19	HX OT2 open at start	L2	Reset, 19

5 star heaters only.

* Shut down type dependent on current operating status.

SSD Safety shut down: Reset not required.

L1 Lockout 1: User reset from SCC (press RESET twice), or Manual t/stat off-on-off-on - wait 5 seconds at each state, or Power off - power on.

L2 Lockout 2: Reset from SCC service mode only

4 & 5 STAR HEATERS			
Code No	Description	Shut down type	SCC display
1	P-55 closed at start	L1	Reset, 1
2	P-55 failed to close	L1	Reset, 2
3	P-55 open during run	SSD	Normal
* 4	Thermistor > 70°C during run	SSD	Normal
5	Thermistor not connected or short circuit	L1	Reset, 5
7	Ignition failure	L1	Reset, 7
# 8	P-cond closed at start	L1	Reset, 8
9	Internal memory failure	L2	Reset, 9
* 10	HX OT1 opened	SSD/L1	Normal
* 11	EFS shutdown	SSD/L1	Normal
12	P-100 closed at start	L1	Reset, 12
13	P-100 failed to close	L1	Reset, 13
14	P-100 open > 30 sec during run	SSD	Normal
15	Thermistor in cool location in duct	SSD	Normal
16	Thermistor not installed in outlet duct	L1	Reset, 16
# 17	Condensate detected in run	SSD	Normal
# 18	Condensate detected at start	L1	Reset, 18
19	HX OT2 open at start	L2	Reset, 19

If the heater still does not start or operate correctly after running through these troubleshooting and diagnostic checks contact:

WARRANTY SERVICE: 1300 650 644
TECHNICAL SUPPORT: 1300 650 399

Please have your appliance model number, serial number, and any displayed fault codes available prior to calling.

