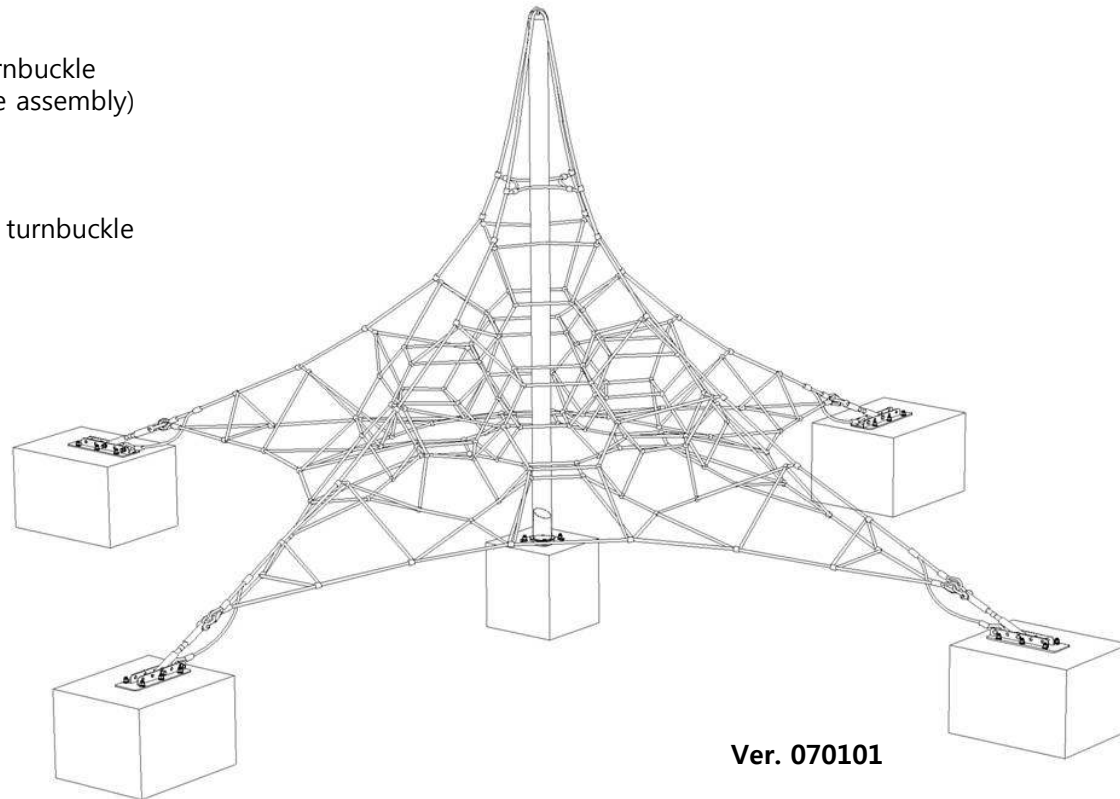


**Safety Checklist after first assembly**

- Test intervals of Safety: 6 months
- Test Component and contents:
  1. Removing the reticulated system:
    - Check of removing condition each rope
    - Screwing the turn buckle and conversion the turnbuckle in anchors plate(see for this workstep turnbuckle assembly)
  2. Abrasion condition of rope:
    - Checking of all rope surface
    - Strengthened of rope: Coating on the surface
  3. Attachment condition of the anchors plate and turnbuckle
  4. Screwing condition of all bolt
  5. Galvanizing condition of the steel component:
    - Protection of steel component from corrosion.

● Measure  
In case of the appearance the defect detail is repaired usually within 3 days after checking.

**SHINHEUNG ENG**  
 1046-3, Najeon-ri, Saengnim-myeon,  
 Gimhae-si Gyeongsangnam-do, 621-821, Republic Of Korea  
 Tel) +82. 55. 326. 9096~7  
 Fax) +82. 55. 326. 9022  
 E-mail) gswebinfo@chol.com  
 Web site) www.gsweb21.com



Ver. 070101

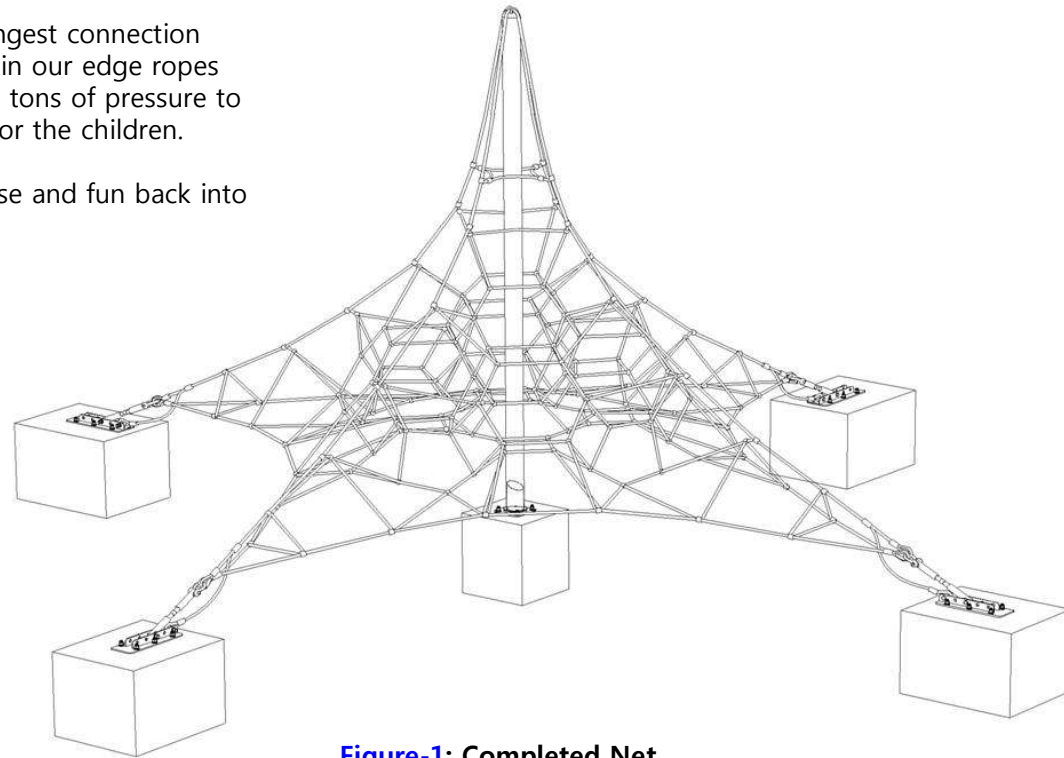
**Features**

This series is a pyramid-style climbing structure made of steel-loaded Nylon cables and comes protected against UV.

GS Web uses the highest steel content and the strongest connection materials in the industry, including a steel-wire core in our edge ropes and connection points crushed in place with over 75 tons of pressure to ensure long life of the games and maximum safety for the children.

GS Web Nets help bring movement, balance, exercise and fun back into the playground.

- Ages: 3 to 8 years**
- Capacity: 27 children**
- Size: L: 15' 7" / 4.74m**
  - W: 15' 7" / 4.74m**
  - H: 10' 6" / 3.2m**
- Use zone: L: 25' 5" / 7.74m**
  - W: 25' 5" / 7.74m**



**Figure-1: Completed Net**

**Safety area**

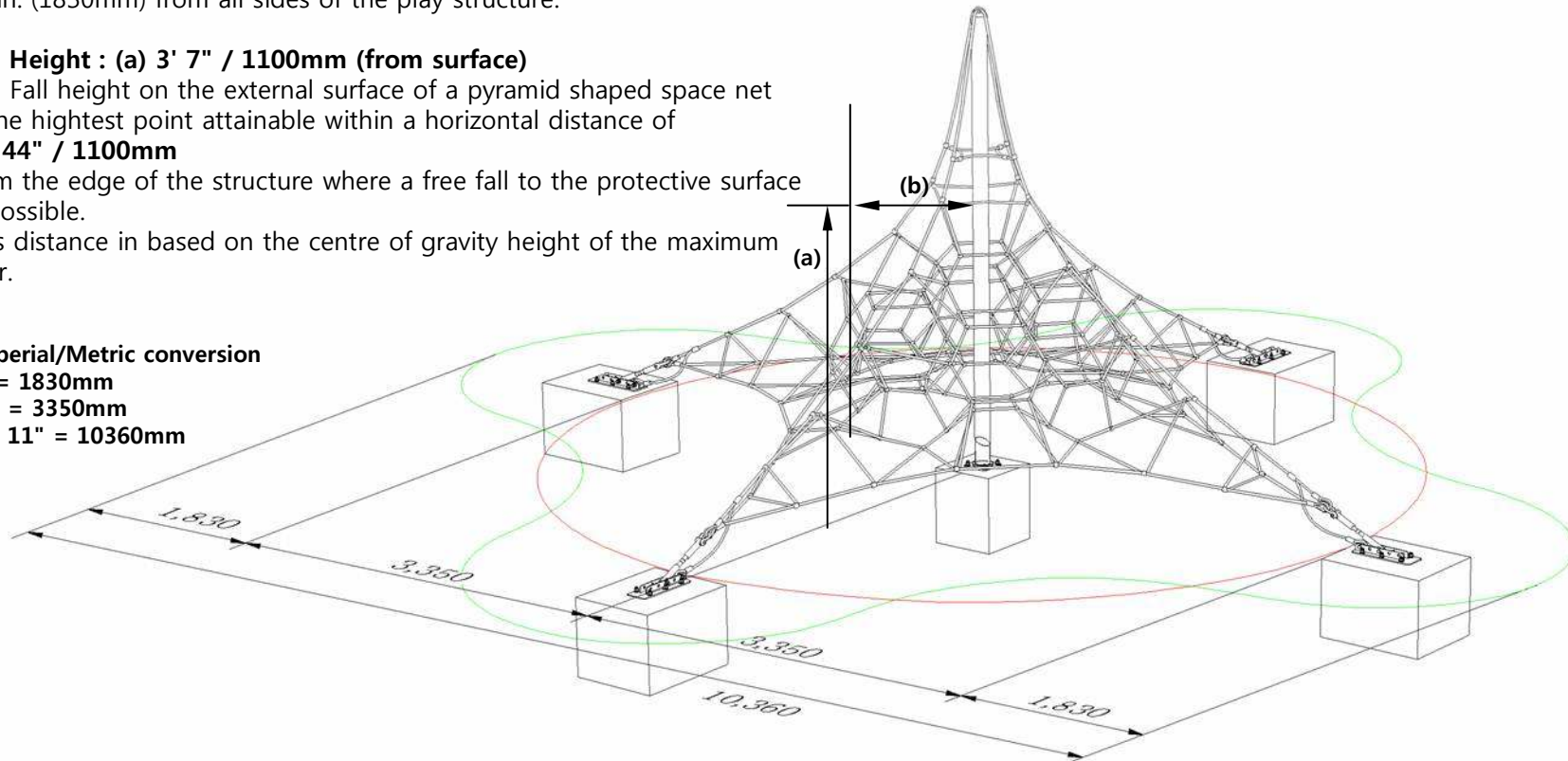
The requirements for space and safety clearances are taken from BS-EN 1176-1 / ASTM-F1487 / CSA Z614  
 The use zone for stationary play equipment shall extend no less than 72 in. (1830mm) from all sides of the play structure.

**Fall Height : (a) 3' 7" / 1100mm (from surface)**

The Fall height on the external surface of a pyramid shaped space net is the highest point attainable within a horizontal distance of **(b) 44" / 1100mm** from the edge of the structure where a free fall to the protective surface is possible.  
 This distance is based on the centre of gravity height of the maximum user.

**Imperial/Metric conversion**

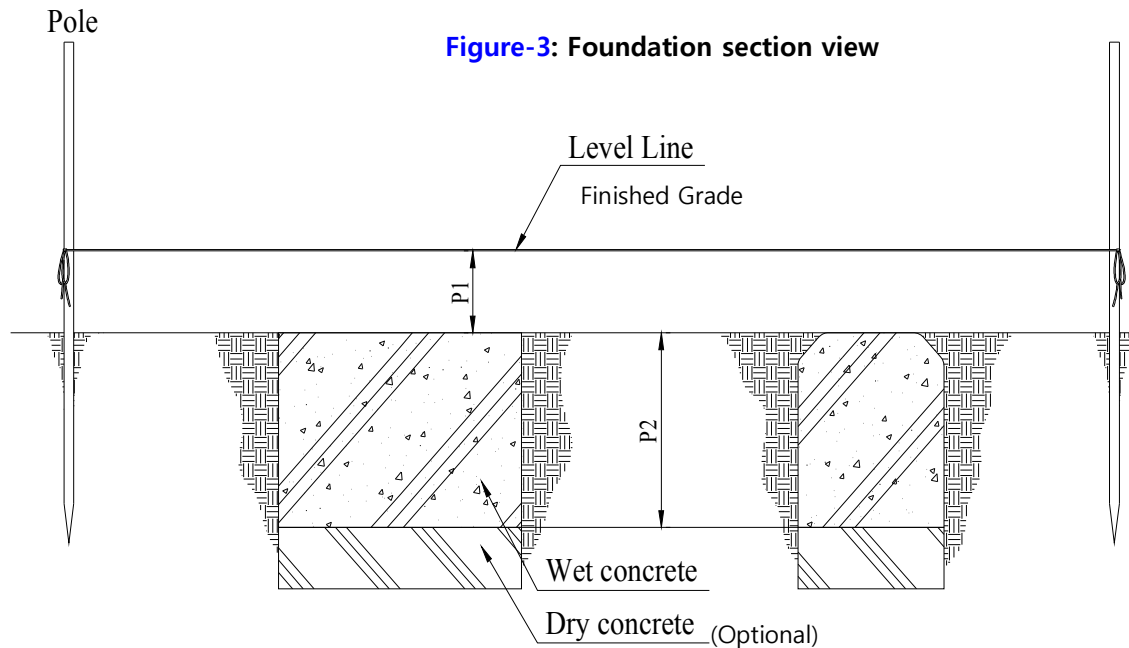
- 6' = 1830mm
- 11' = 3350mm
- 33' 11" = 10360mm



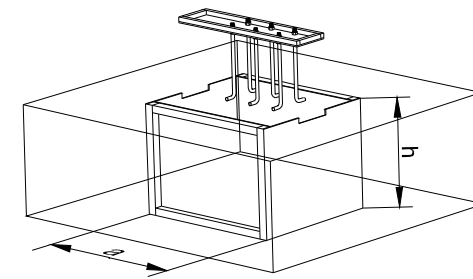
**Figure-2: Install and safety area**

**Foundation**

Please refer to GS-W1001-1 drawing for exact installation dimensions



**P1 = Depth below finished Grade (12" / 300mm)**  
**P2 = Depth of concrete footing (27-1/2" / 700mm)**

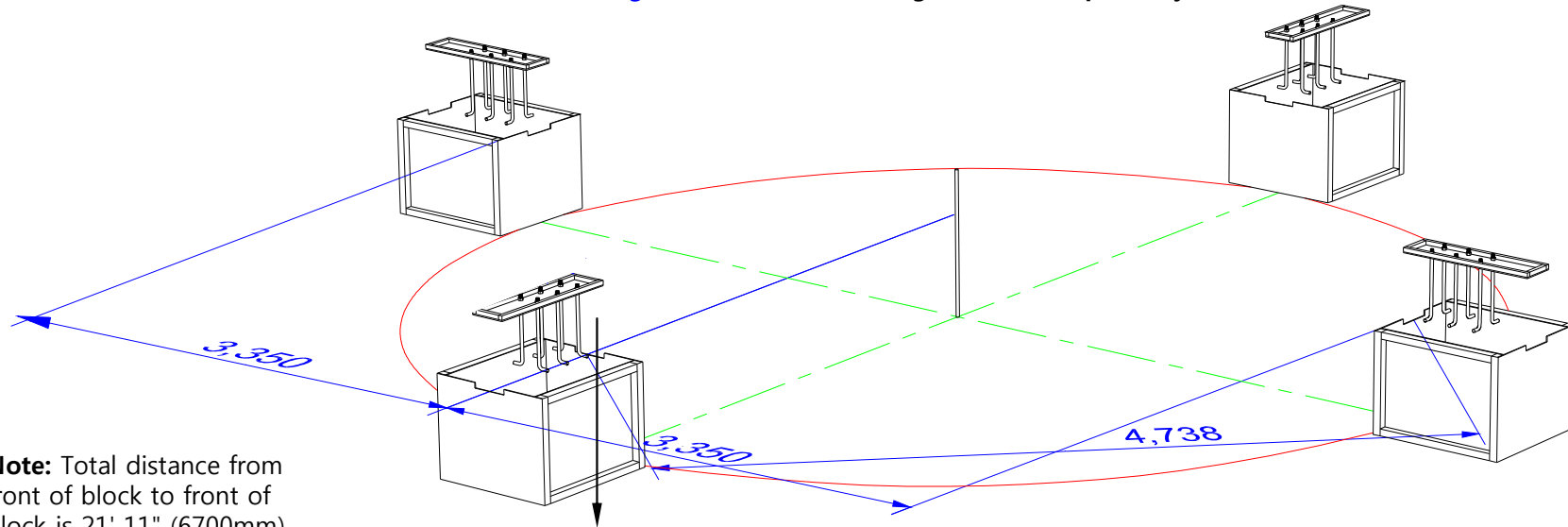


**Figure-4 : Excavate enough materials to allow for proper depth of concrete footings**

Also ensure that there is enough space to allow the frame to be positioned properly.

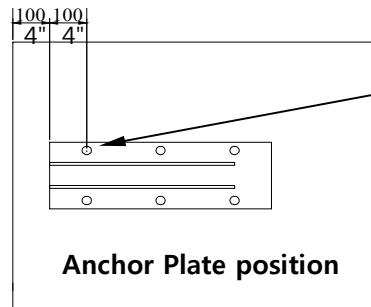
Anchor wood support frame to ground with pickets to prevent the frame from moving while concrete is poured and sets.

**Figure-5: Concrete footing and Anchor plate layout**



**Note:** Total distance from front of block to front of block is 21' 11" (6700mm)

**Imperial/Metric conversion**  
11' = 3350mm  
15' 6" = 4738mm

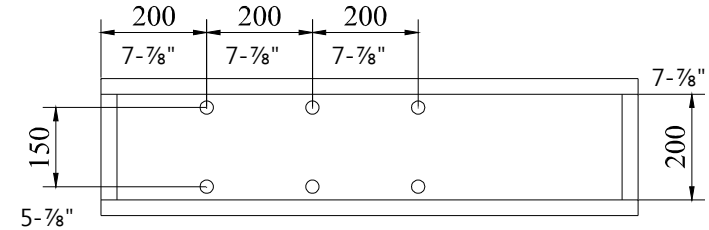


**Positioning Anchor plate on footing**  
[CF] 'L' anchor hole  
Front edge of anchor plate must be installed 4" / 100mm from edge of concrete footing.

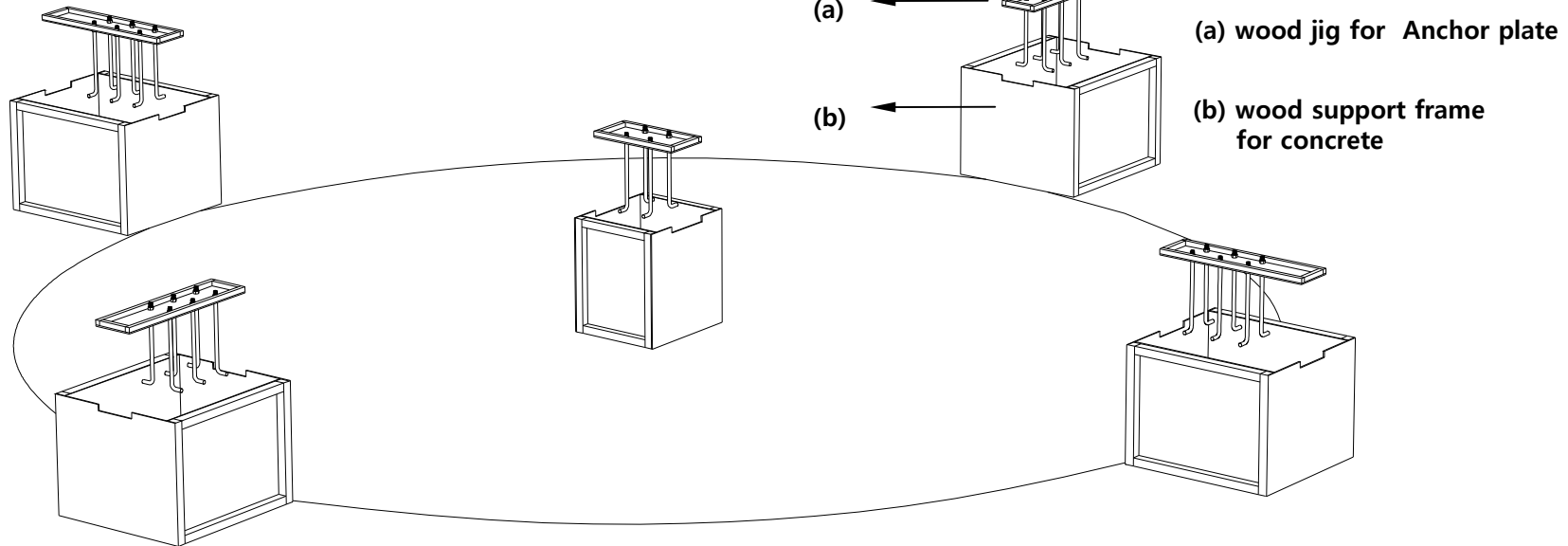
**Assemble wooden support frames \***

4 frames (39-1/2" / 1000mm L x 31-1/2" / 800mm W x 27-1/2" / 700mm H)  
1 frame (24" / 600mm L x 24" / 600mm W x 27-1/2" / 700mm H)

\*Use 1/2" (min) plywood; not included in package



**NOTE:** Use anchor plate as guide for exact measurements.



**Figure-6: Wood support frame**

[Concrete]

Pour concrete\* into wooden support frame until flush to top edge  
Allow 3-5 days for concrete to cure before proceeding to next step.

\*Concrete is to be wet concrete with minimum 25 MPA / 3500PSI.

[concrete footing work]  
Pour wet concrete in the wooden support frame

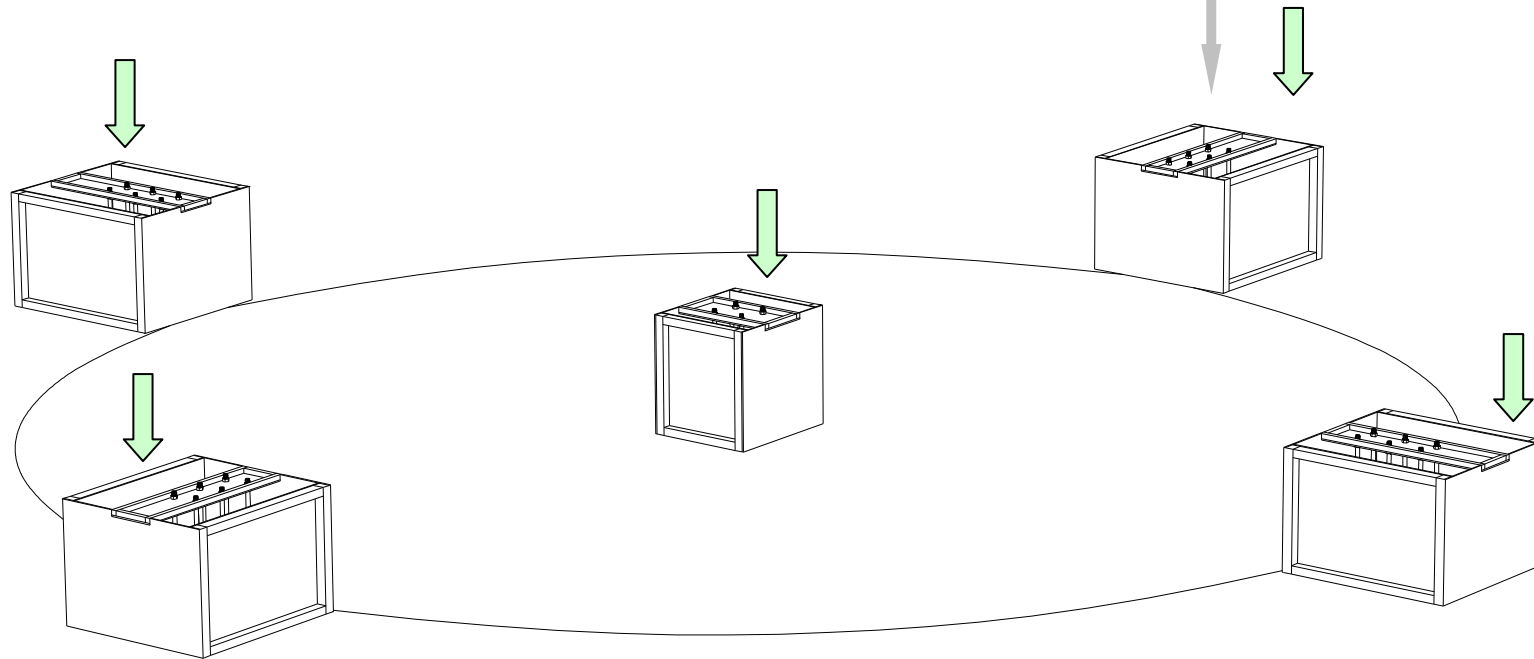
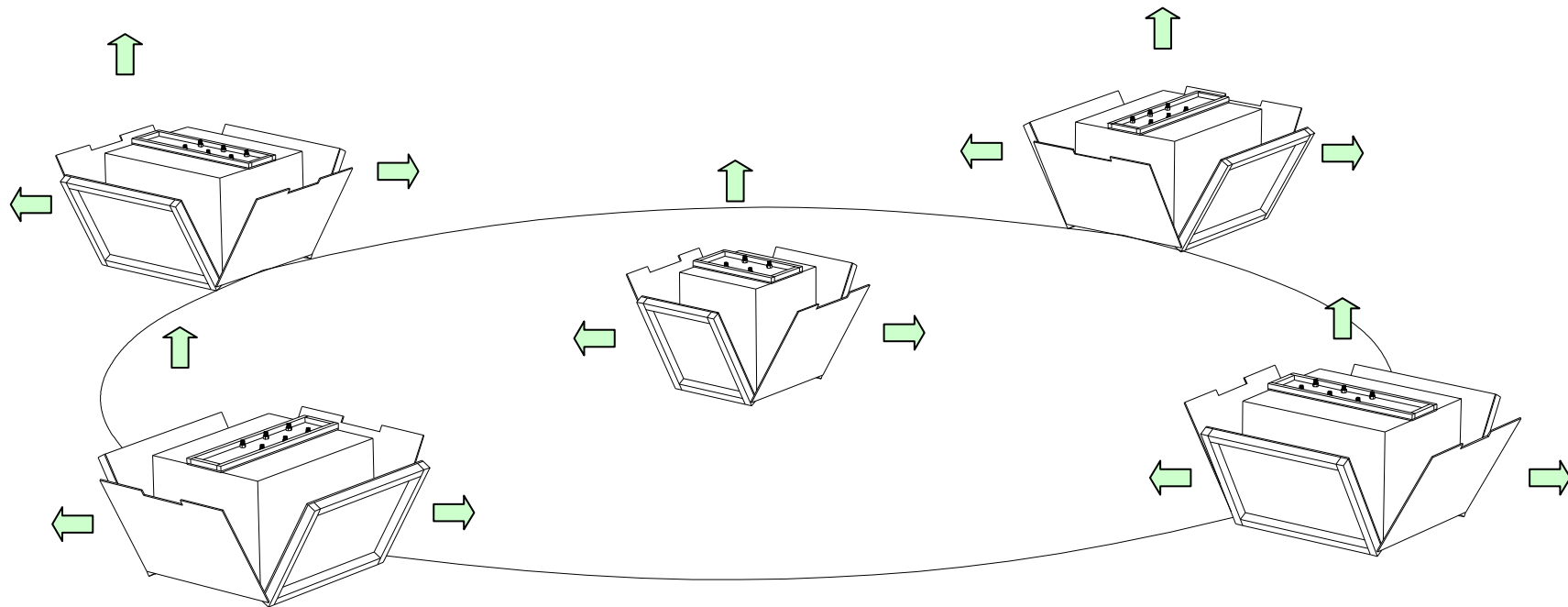


Figure-7: Concrete footing work

**Remove wood support frame from dry concrete blocks**

After concrete has cured enough, remove frame and replace soil in area around footing to subgrade level



**Figure-8: remove wood support frame**



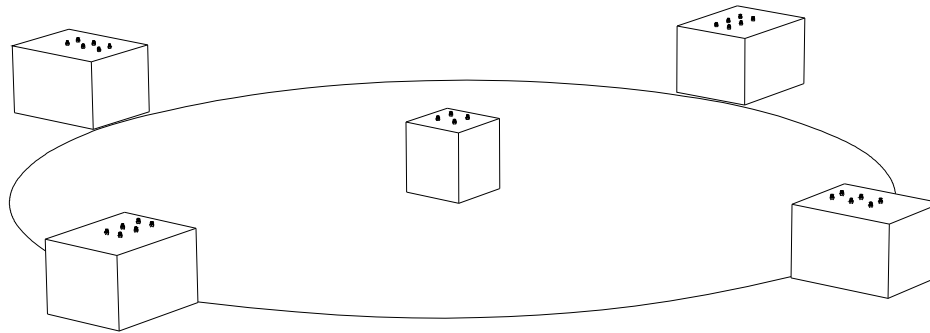


Figure-9: concreted block -  
clean threads of "L" anchor bolts

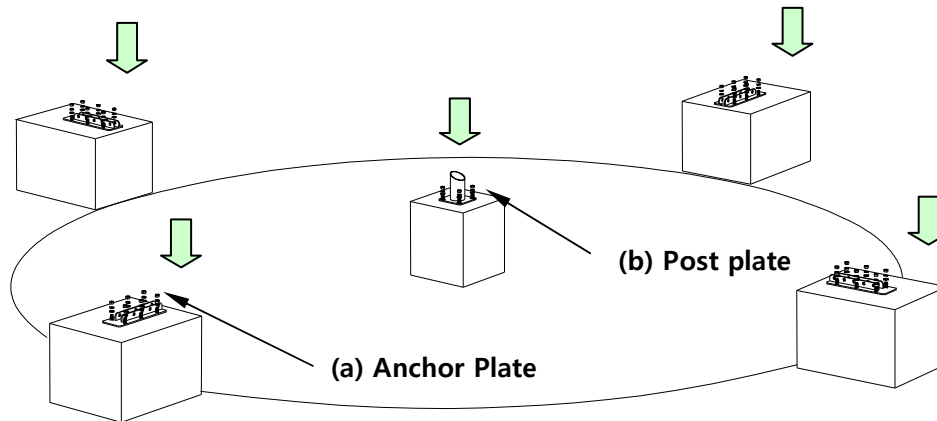
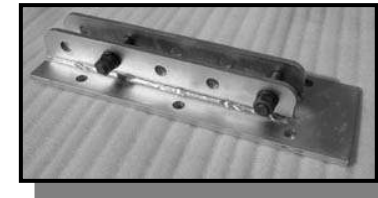


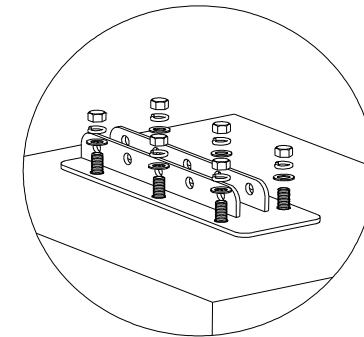
Figure-10: Attach Anchor plate to footing  
with flat washer, locking washer and nut.



(a) Anchor Plate



(b) Post plate



Post Assembly

Insert Post following nylon string

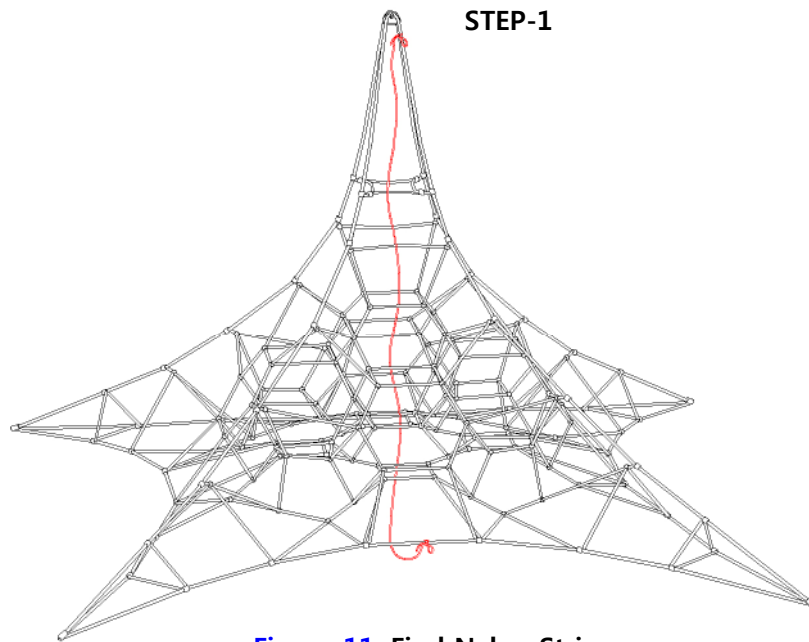


Figure-11: Find Nylon String

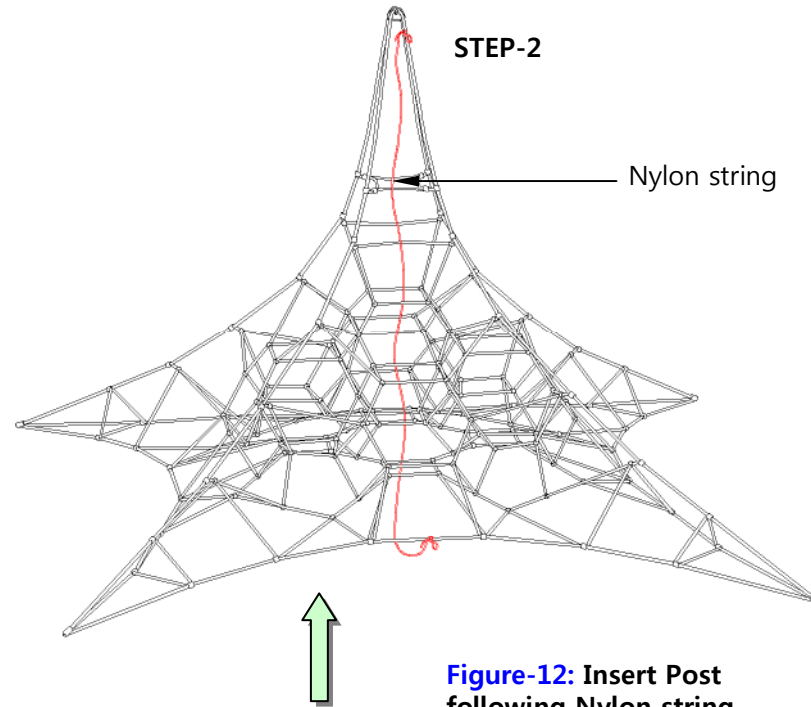


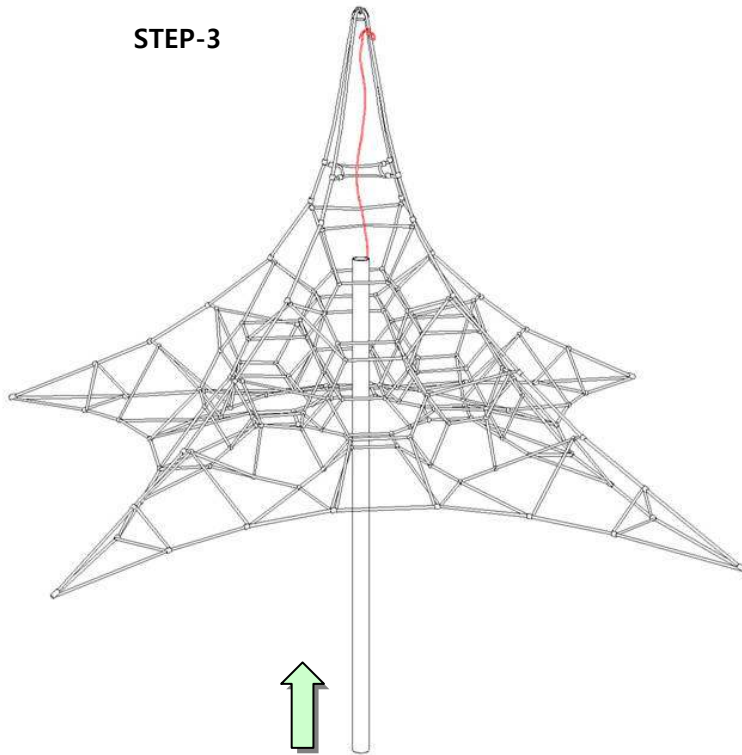
Figure-12: Insert Post following Nylon string

NOTE: Remove string prior to placing cap on post.

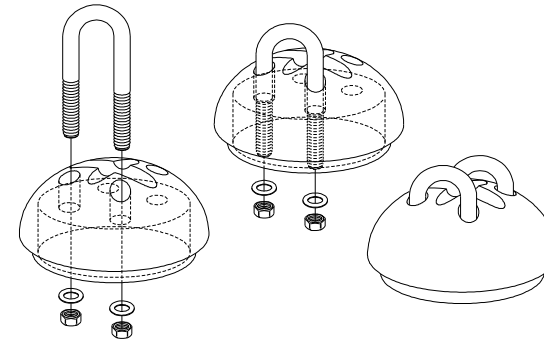
**Place Cap on Post**

Thread the mast through the net's center (per diagrams below, or following factory-installed guide string). Press the cap (already attached to the top of the net) into the mast's top end.

**STEP-3**

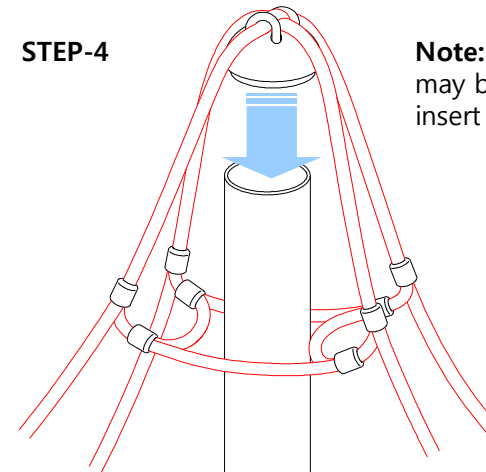


**Figure-13: Insert Post into the Center of Net.**



**Figure-14: U-bolt assembly.**

**STEP-4**

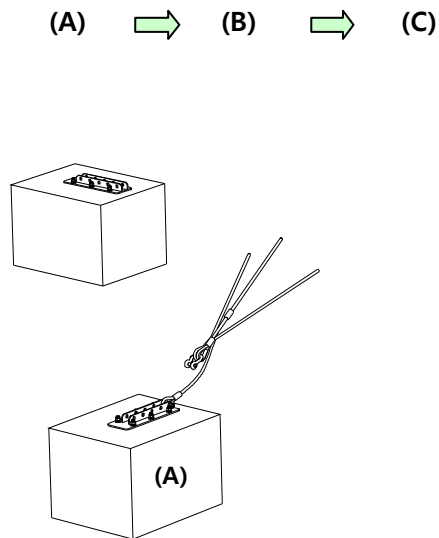


**Note:** Rubber mallet may be required to insert cap into post.

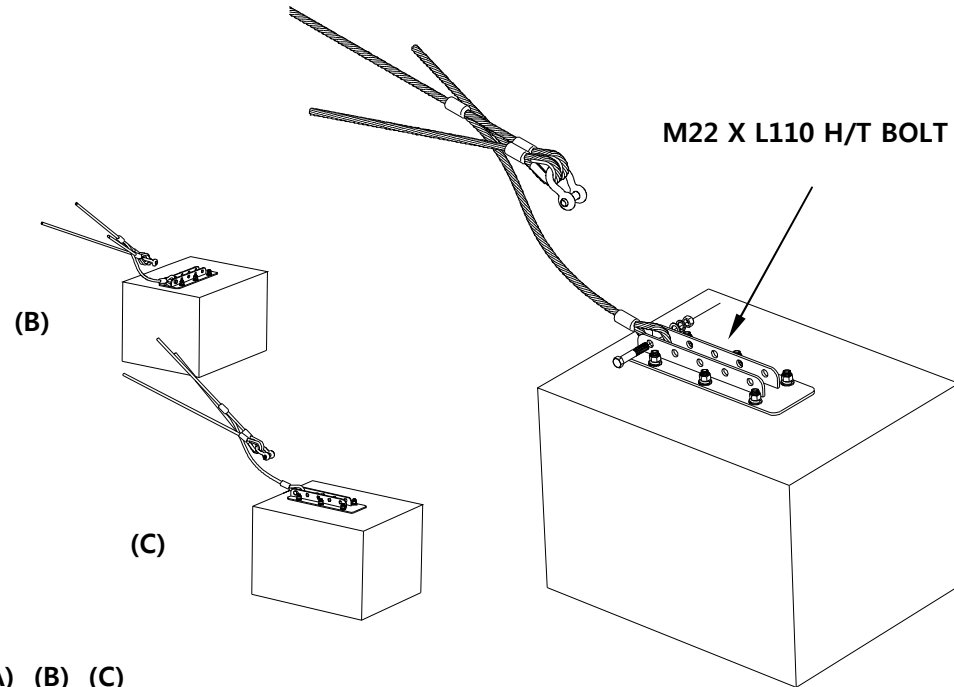
**Figure-15: Post cap assembly.**

**Safety Cable Attaching**

Attach safety cable to anchor plates (A) (B) (C) as shown in Figure 16.



**Figure-16: Attach cable to (A) (B) (C)**



**Figure-17: Safety cable Assembly**

After successfully preparing the net and mast assembly, attach safety cable with M22 X L110 H/T BOLT to Anchor plate as shown below

It is strongly recommended that 3-4 workers lift the net into place.

[Working Process] (A) → (B) → (C) → (D) → (E)

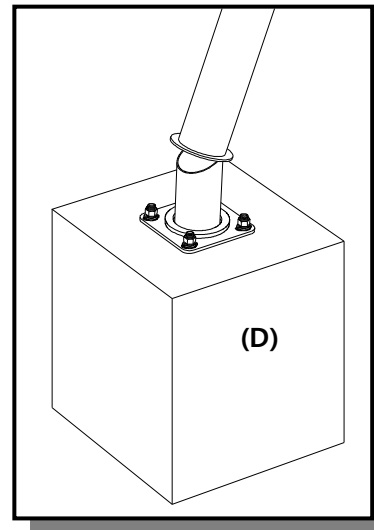
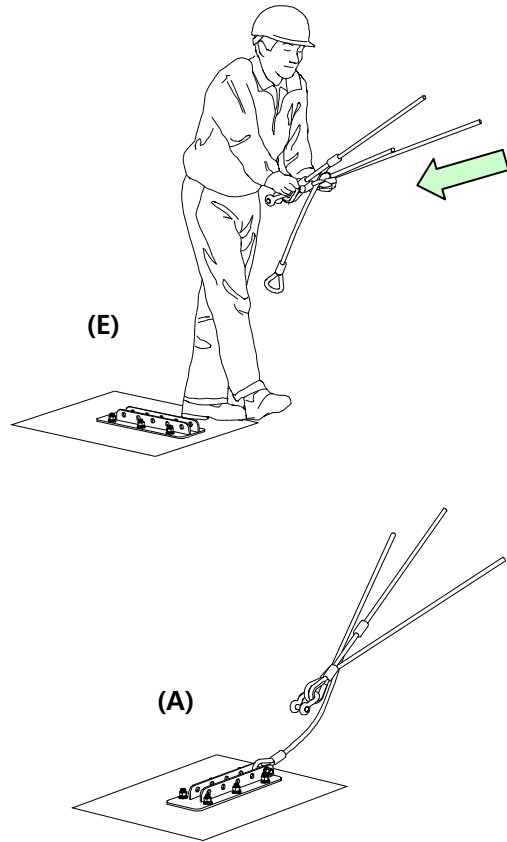


Figure-18: Centre Post

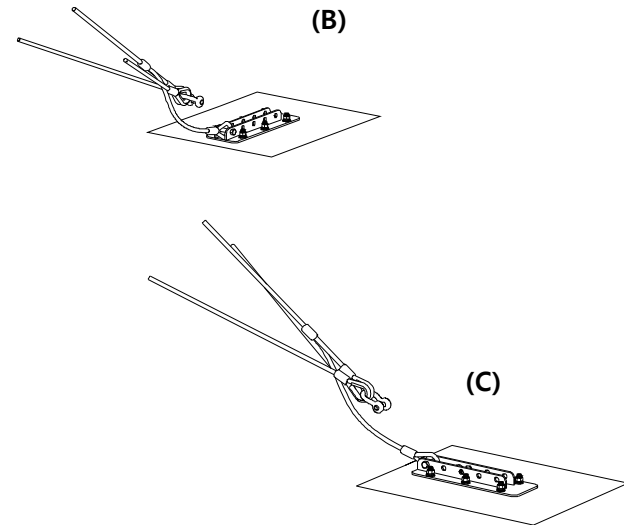


Figure-19: Safety cables attached

After standing up the Net, Attach remaining safety rope and Turnbuckles

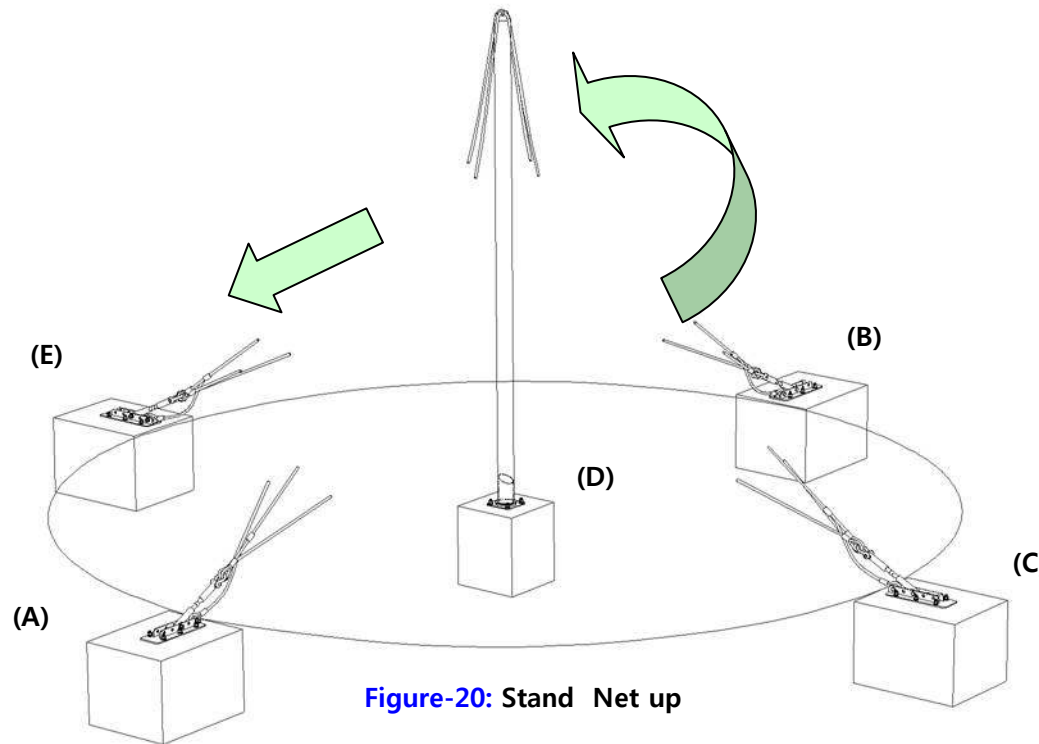
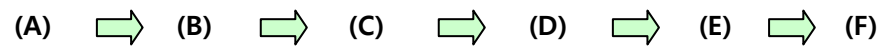
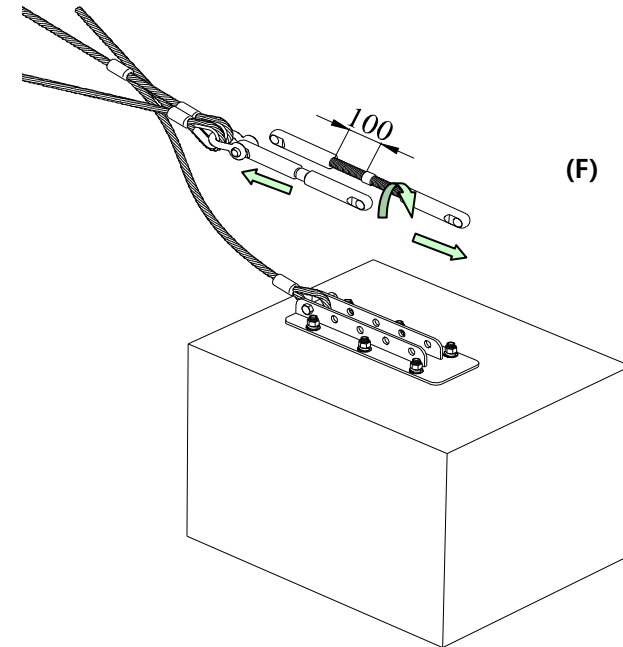
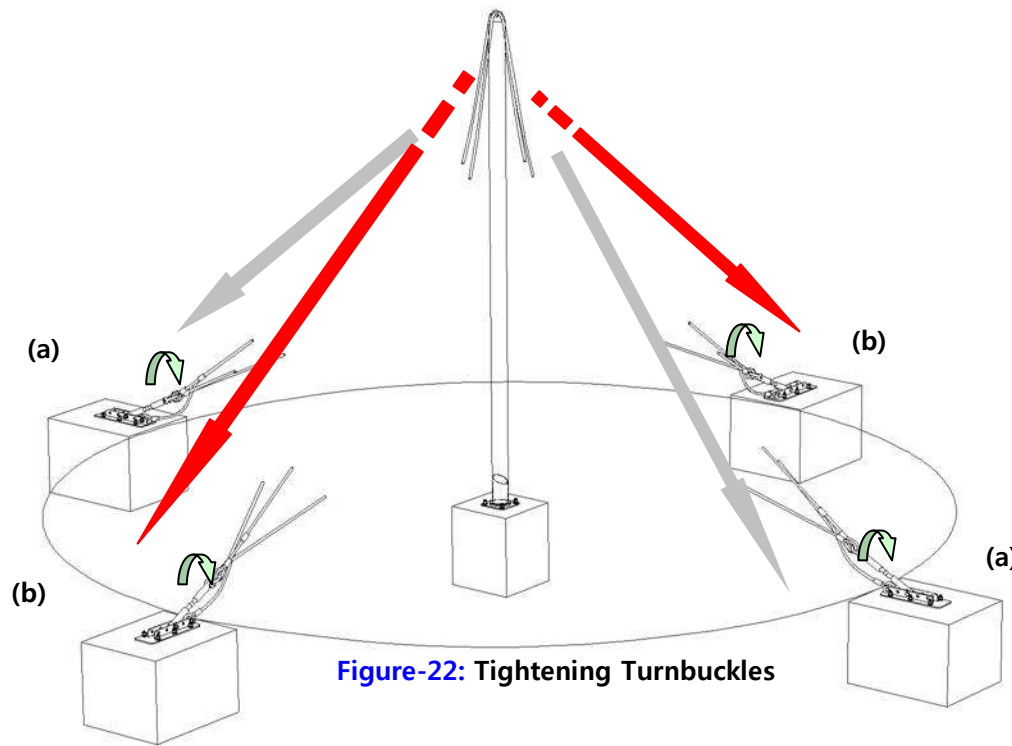


Figure-21: Loosen Turnbuckle: all the way (about 100mm), leaving only 4 or 5 threads attached



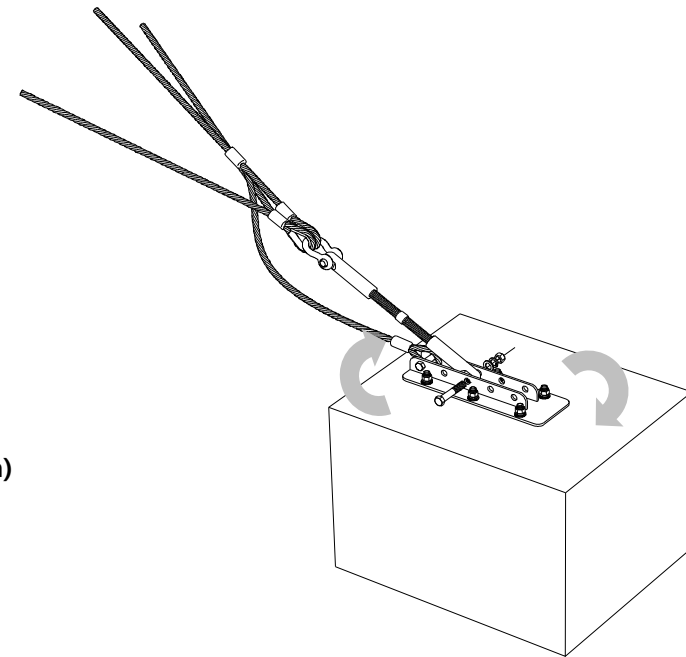
**Anchor plate + Turnbuckle**



**NOTE: Make sure post is level before tightening and remains level during process.**

- (a) + (a) **Tighten Rope with Turnbuckles at the Same time**
- (b) + (b) **Tighten Rope with Turnbuckles at the Same time**

**Figure-23: Turnbuckle assembly**



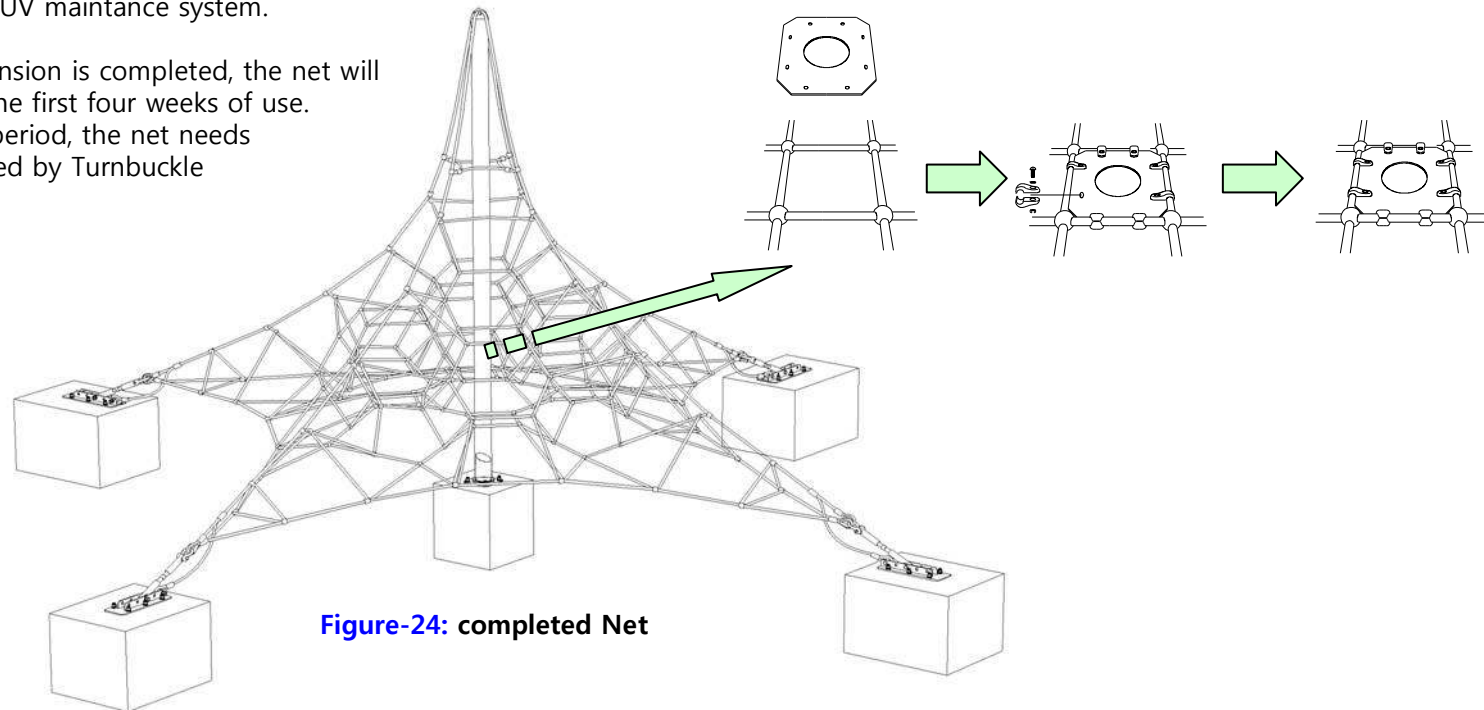
**Maintenance information**

Please tighten rope with Turnbuckle properly.  
If you strain the net too much, it may cause damage.  
It is also recommended that subsequent checks on tension should be carried out at monthly intervals and adjusted as required.  
This will increase the overall longevity of the product.

**Checking: 1 month**

Refer to IPEMA and TUV maintenance system.

After Net structure tension is completed, the net will stretch slightly over the first four weeks of use.  
Following this initial period, the net needs to be fully re-tensioned by Turnbuckle after 1 year.

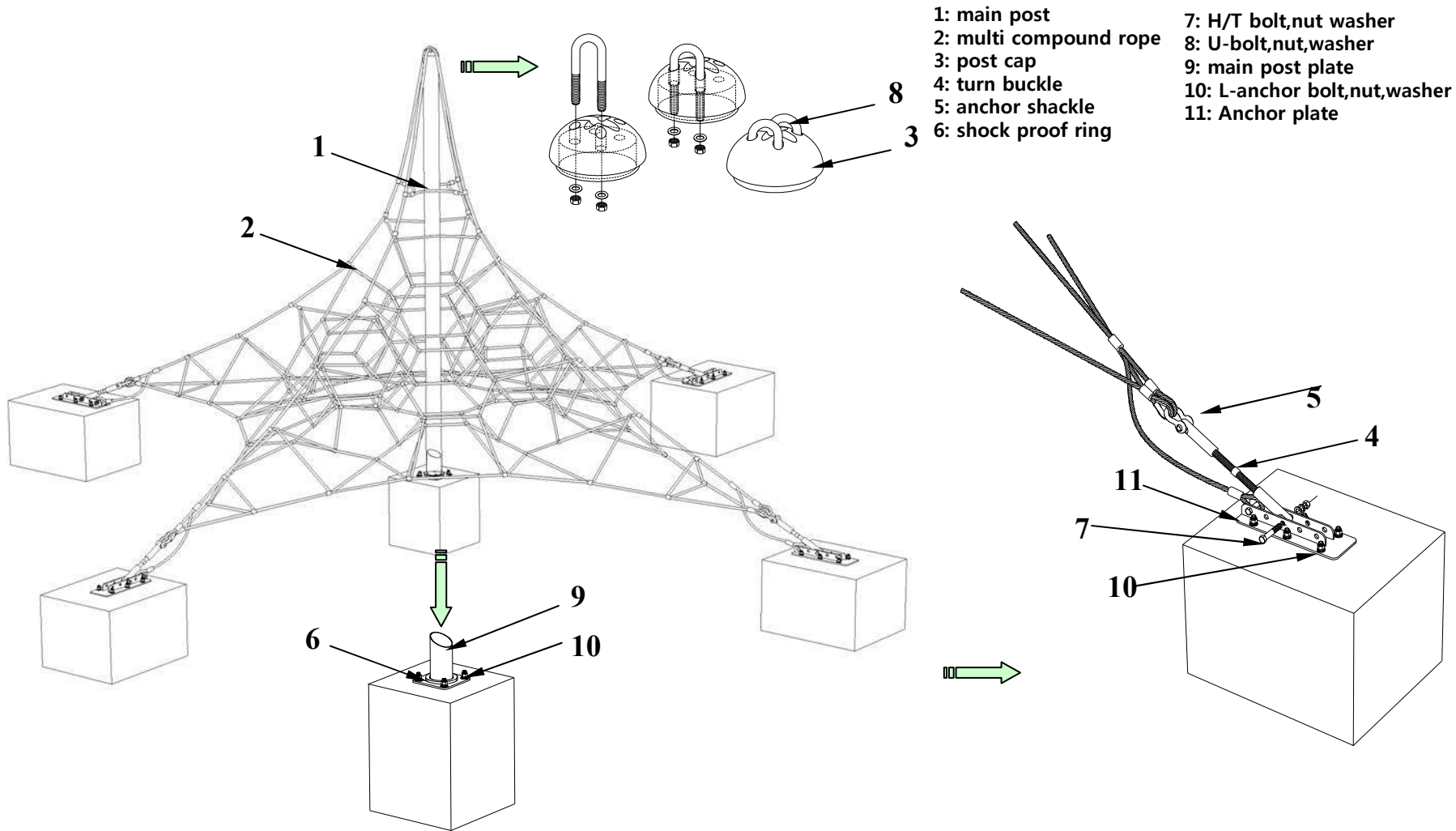


**Figure-24: completed Net**

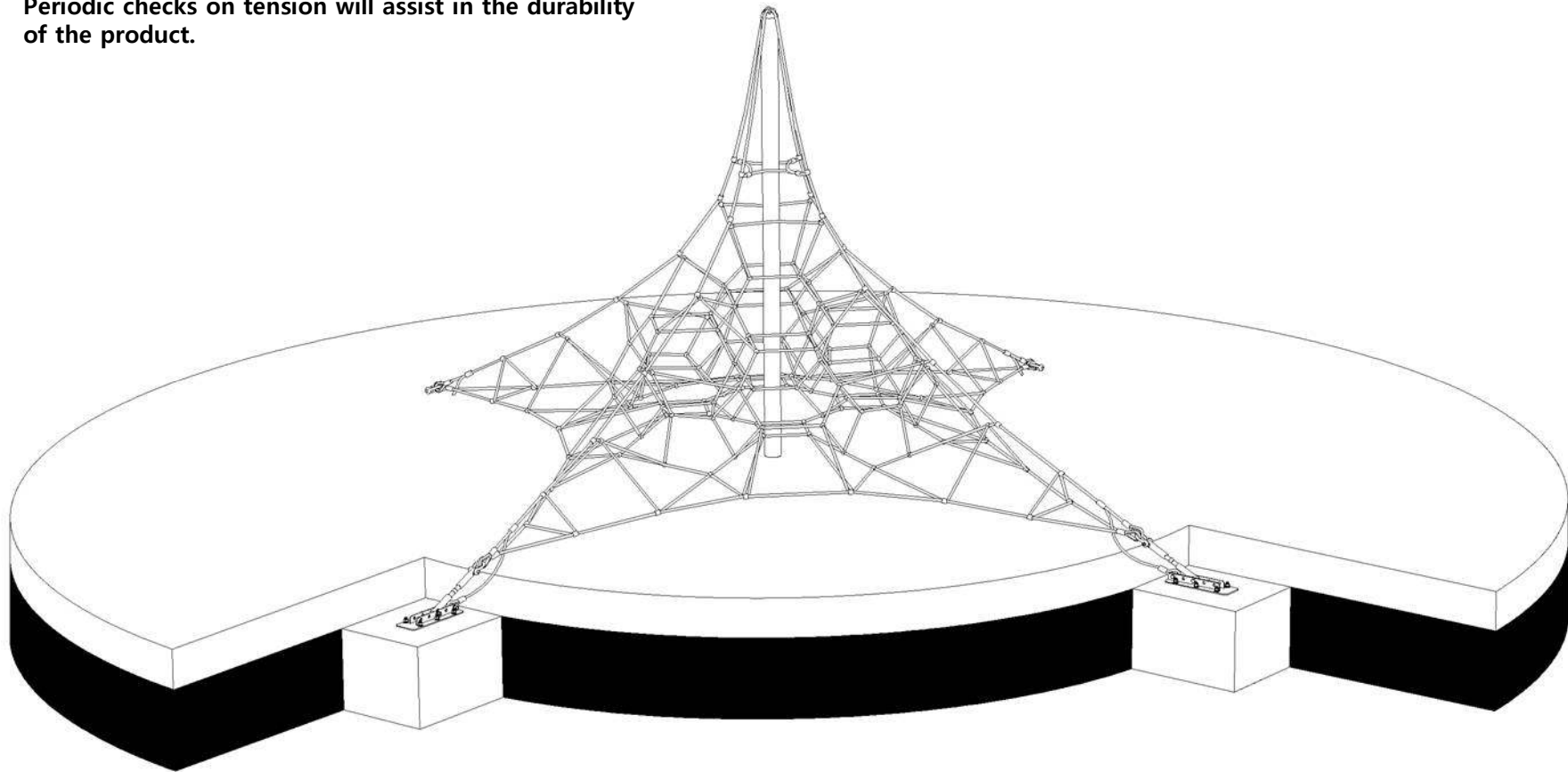


**SINGLE MAST NET CLIMBER**  
Anchor Plate Assembly

**MODEL NO.**  
**GS-W1001-1**



A weekly check of the activity net is recommended to ensure that no acts of vandalism have damaged the rope. Periodic checks on tension will assist in the durability of the product.



**A. General safety measures**

On the playground there should be a sign(pictogram) giving the following information:

- a) general emergency telephone number;
- b) telephone number to contact maintenance personnel;
- c) name of the playground;
- d) address of playground; and
- e) other relevant local information, if applicable.

The entry, exit and emergency paths to and from a playground, intended for use by the public and emergency services, should be accessible and free of obstacles at all times.

NOTE Attention is drawn to local regulations.

**B. Procedures**

Defects that occur during operation and which put safety at risk should be corrected without delay. If this is not possible, the equipment should be secured against use e.g. by immobilization or removal.

There should be written operational procedures covering the measures to be taken in the event of accidents, fire and the like.

Until unsafe equipment is repaired and released for use, access by the public should be prevented. Information about accidents brought to the attention of the manager should be recorded on a form that includes the following details:

- a) date and time of accident;
- b) age and sex of victim and clothing worn, Including footwear;
- c) equipment involved;
- d) number of children on site at the time of the accident;
- e) description of accident;
- f) injury sustained including part(s) of body affected;
- g) action taken;
- h) witness statements;
- i) any subsequent equipment modification;
- j) weather conditions; and
- k) any other relevant information.

### **C. Routine maintenance**

To reduce accidents, the owner or operator should ensure that an appropriate routine maintenance schedule is established, implemented and maintained. This should take into account local conditions and the manufacturer's instructions that can affect the necessary inspection frequency. The schedule should list the components to be maintained and should also give procedures for dealing with complaints and breakdowns. The routine maintenance of playground equipment and surfaces should consist of preventative measures to maintain their level of safety, performance and compliance with the relevant part(s) of EN 1176. Such measures should include:

- a) tightening of fastenings;
- b) re-painting and re-treatment of surfaces;
- c) maintenance of any impact attenuating surfaces;
- d) lubrication of bearings;
- e) marking of equipment to signify loose fill finished surface level;
- f) cleaning;
- g) removal of broken glass and other debris or contaminants;
- h) restoring loose fills to the correct level; and
- i) maintenance of free space areas.

### **D. Corrective maintenance**

Corrective maintenance should include measures to correct defects, or to re-establish the necessary levels of safety of the playground equipment and surfaces. Such measures should include:

- a) replacement of fastenings;
- b) welding of welding repairs;
- c) replacement of worn or defective parts; and
- d) replacement of defective structural components.

### **E. Personal safety**

Repairs during operation that could put the safety of maintenance personnel of the public at risk, should be avoided.

### **F. Equipment alterations**

Alterations to parts of a piece of equipment or structure that could affect the essential safety of the equipment should only be carried out after consultation with the manufacturer or a competent person.