

Maintenance Bypass Switch (MBS) Operation & Installation Manual

Basic Maintenance Bypass Switches for Powerware 9155 & 9355 up to 15kVA

Part Numbers:

For 9155 8-15kVA: 9155MBS15kVA

For 9355 8-15kVA: 9355MBS15kVA



The maintenance bypass switch may be supplied as an integrated MBS mounted on the back of the UPS, or may be supplied as a separate MBS for wall mounting near the UPS.

The operation of the MBS is allowed for a trained person only who is familiar with the UPS behaviour and functions. The full UPS wiring diagram with a MBS switch is presented in the installation part of the manual.

Note! The MBS consists of three switches and failure to understand the correct sequence may drop the critical load.

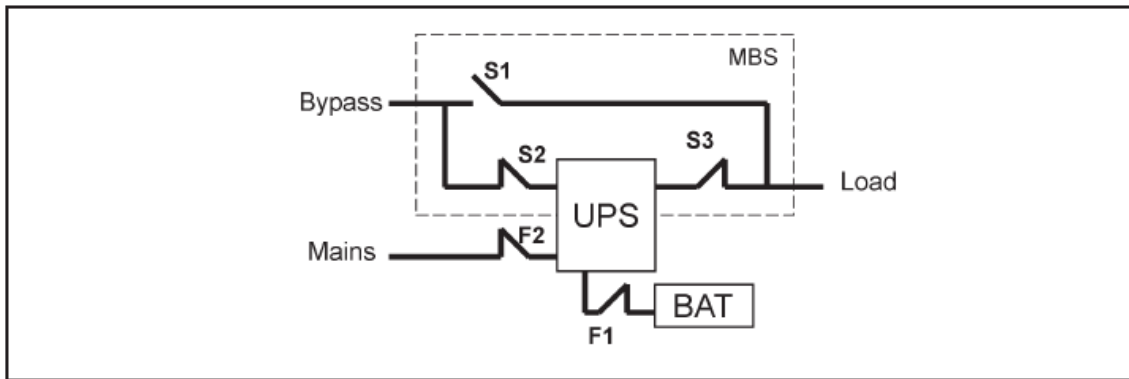

Figure 1. The normal positions of the three MBS switches.

Turn UPS from normal mode to mechanical bypass

The procedure to turn the UPS to mechanical bypass switch is described below.

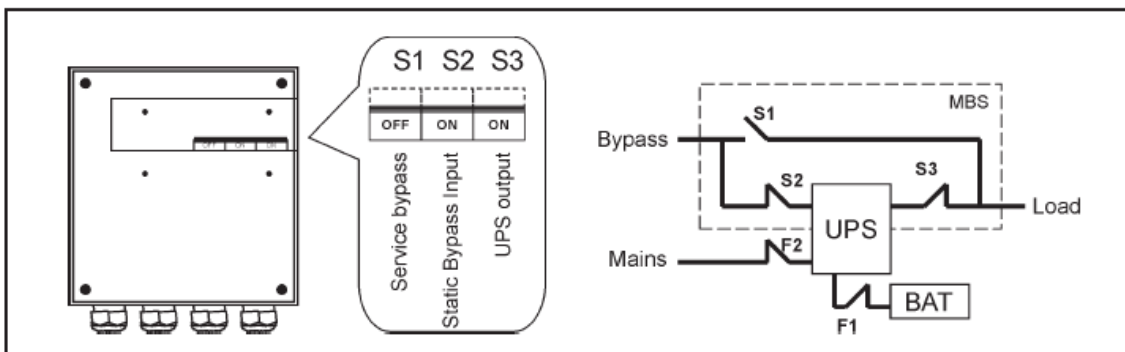
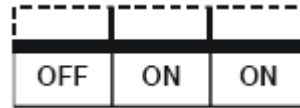

Figure 2. The normal (UPS supplying the load) positions of the three MBS switches.

No break transfer from normal mode to Service Bypass:

1. The normal start position is as shown:



2. Use the UPS LCD commands to transfer the UPS to internal static bypass mode(refer UPS User Manual). Remember to verify the transfer before proceeding to the next step.

3. Remove the locking plate of the S1-3 switches.

4. Turn ON the S1 switch to bypass UPS:



5. Turn OFF the S3 switch to disconnect UPS output:

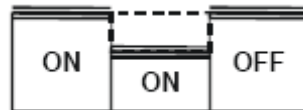

6. Use the UPS LCD commands to turn the UPS OFF (refer UPS User Manual).

7. Turn **F1** battery breakers and **F2** input breaker in UPS to OFF position.

8. Turn OFF the S2 switch to disconnect UPS bypass input:

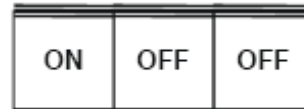

9. Remount the locking plate of the S1-3 switches to the position to prevent the use of them.

10. UPS is now in the mechanical bypass mode, see below:

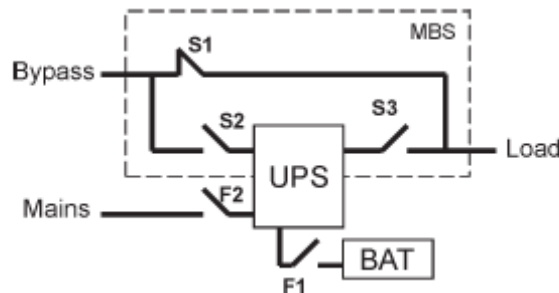

Figure 3. Bypass Mode switch positions

Turn UPS from mechanical bypass to normal mode

The procedure to turn the UPS back to normal mode is described below.

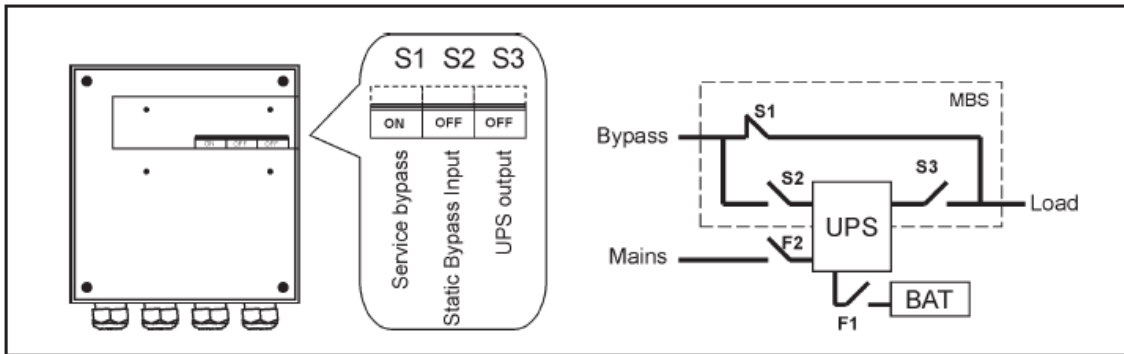

Figure 4. The service (bypass supplying the load) positions of the three MBS switches.

No break transfer from Mechanical Bypass to normal mode:

1. The normal start position should be as shown:



2. Remove the locking plate of the S1-3 switches.

3. Turn ON S2 switch to connect bypass input to UPS:



4. Turn the F1 battery and F2 input breakers in UPS to ON position.

5. Use the UPS LCD commands to “Turn UPS on” and wait until it is fully started.

- Make sure the UPS is not displaying any alarms.
- You may verify the output voltage from the meters screen of the LCD.

6. Use the UPS LCD commands to transfer the UPS to internal static bypass. Remember to verify the transfer before proceeding to the next step.

7. Turn ON S3 switch to connect UPS output to load:



8. Turn OFF S1 switch to disconnect bypass output:

OFF	ON	ON

9. Use the UPS LCD commands to transfer the UPS to normal mode.

10. Remount the locking plate of the S1-3 switches to the position to prevent the operation of the switches.

11. UPS is now in Normal mode, see below:

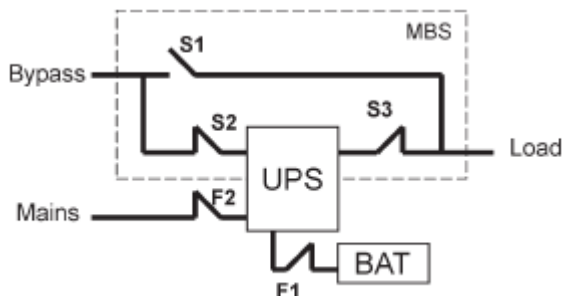
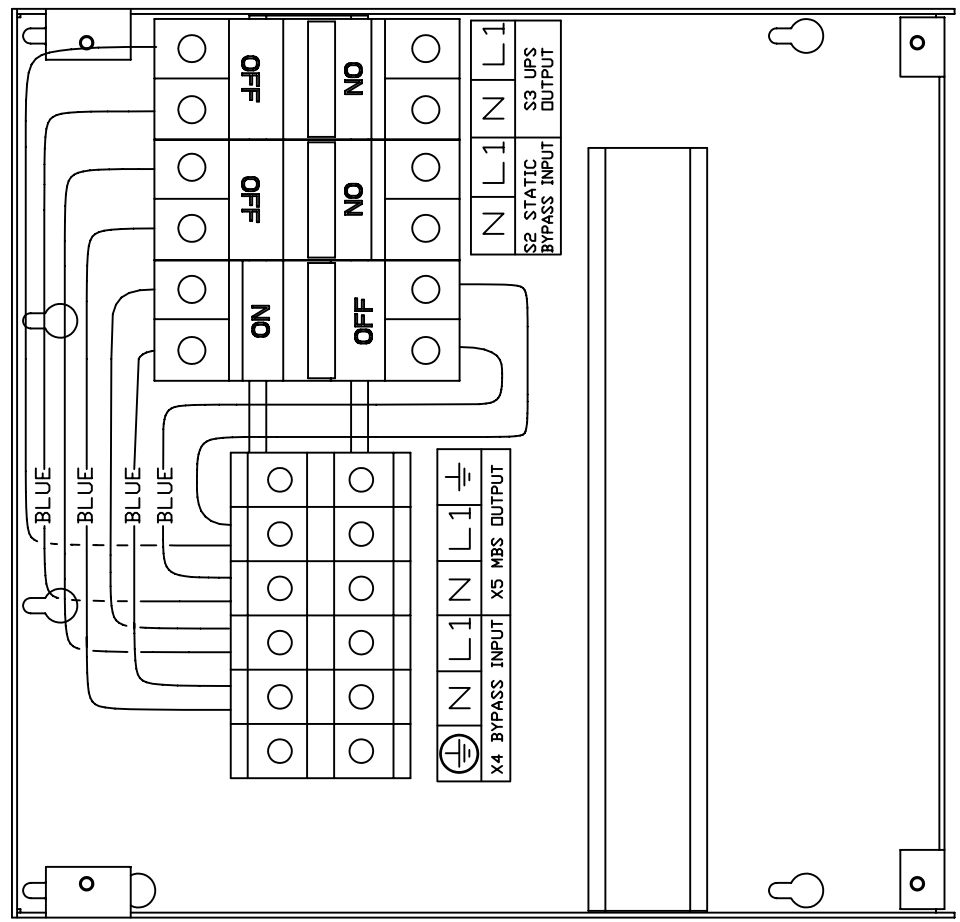

Figure 5. Normal Mode switch positions

1 2 3 4 5 6 7 8 9 10 11 12

A B C D E F G H

MBS TERMINALS



230/400 V, 50 or 60 Hz

L1
L2
L3
N
PE

9155-N models have three phase input connections. See details from the User's Guide.

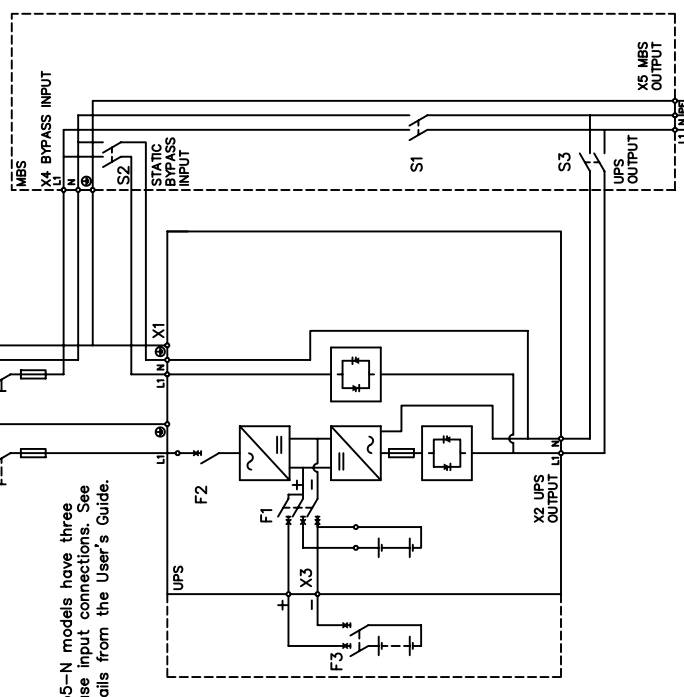

230/400 V, 50 or 60 Hz

L1
N
PE

Rev/ECD no:	REV	REV	REV
Rev/ECD no:	REV	REV	REV

THIS DRAWING CONTAINS PROPRIETARY INFORMATION OR TRADE SECRETS. IT IS TO BE USED ONLY FOR THE MANUFACTURE AND REPAIR OF THE EQUIPMENT IDENTIFIED HEREIN. ANY PART DISCLOSED HEREIN WITHOUT THE PRIOR WRITTEN PERMISSION OF POWERWARE.

POWERWARE

Title External MBS for 9155 8 - 15 kVA
Part number: 1022559

Checked - Approved 27.9.2006 - Loc FIN

No. 1026529
Rev A

Size A2 Page 1/1

1 2 3 4 5 6 7 8 9 10 11 12

A B C D E F G H

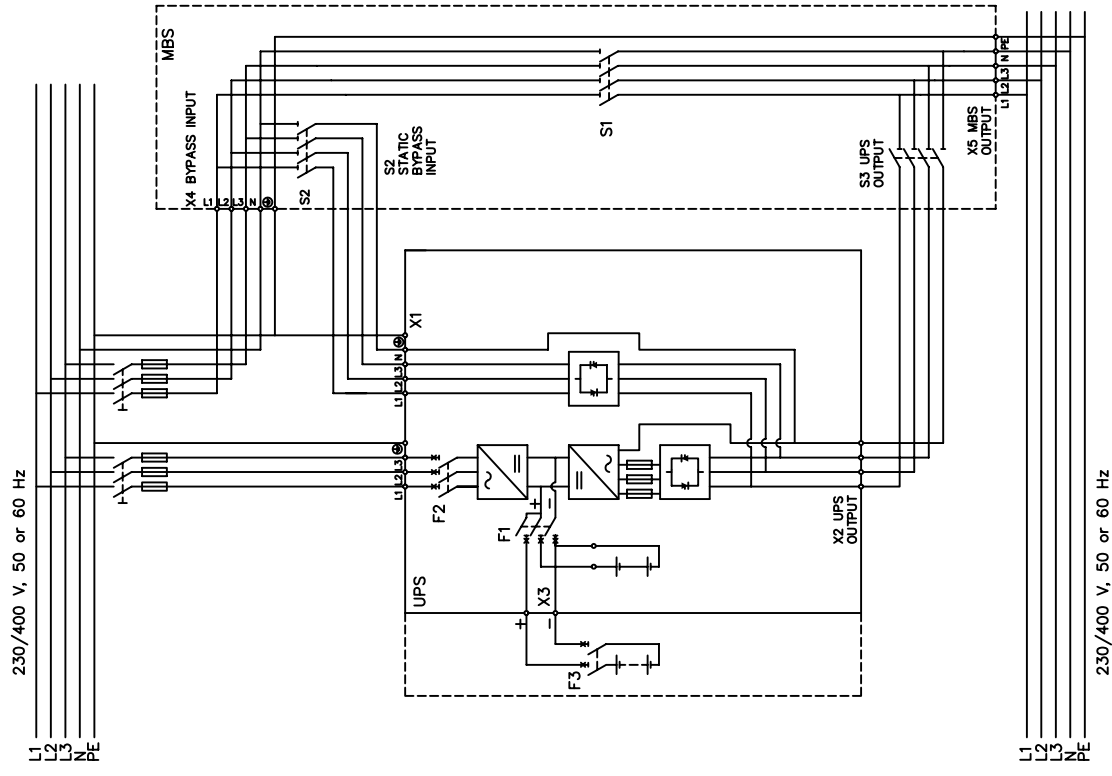

MBS TERMINALS

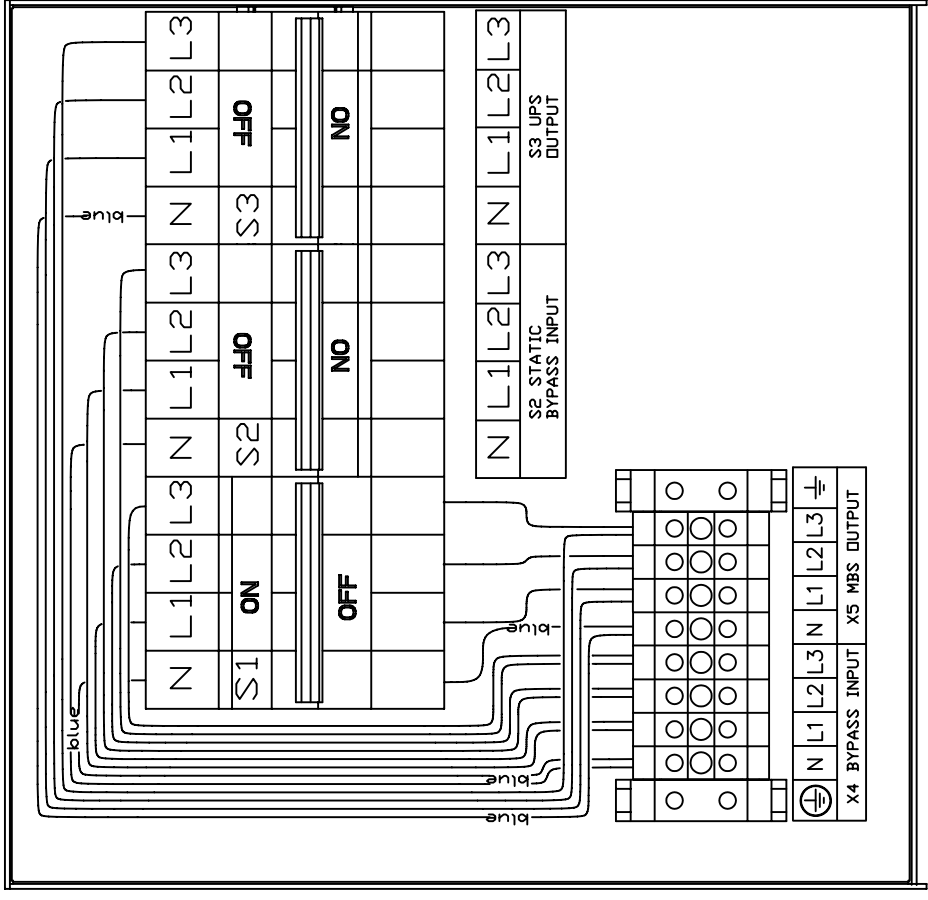

POWERWARE	Title	External MBS for 9355 8 - 15 kVA	-
	Part number:	1022558	No. 1026528
Checked	-	Approved	27.9.2006 -
Loc	FIN	Size	A2
Page	1/1	Rev	A

Rev/ECD no:	Rev	Rev	Rev
Rev/ECD no:	Rev	Rev	Rev
Rev/ECD no:	Rev	Rev	Rev

THIS DRAWING CONTAINS PROPRIETARY INFORMATION OF POWERWARE AND MAY NOT BE REPRODUCED OR TRANSMITTED IN ANY FORM OR BY ANY MEANS, ELECTRONIC OR MECHANICAL, INCLUDING PHOTOCOPYING, RECORDING, OR BY ANY INFORMATION STORAGE AND RETRIEVAL SYSTEM, WITHOUT THE PRIOR WRITTEN PERMISSION OF POWERWARE.