



JVA Z Series Keypad Bus Wiring Installation Manual

Version: 1.2
Date: 16 January 2014
By: Alex Gilmour



Table of Contents

1	Introducing the Keypad Bus	2
1.1	Keypad Bus Wires	2
1.2	Keypad Bus devices	3
1.3	Baud rate.....	4
1.4	Keypad Bus Mk2	4
2	Keypad Bus Installation.....	5
2.1	Keypad Bus Wiring Limitations	5
2.2	Network Layout.....	5
2.3	Wiring Guide.....	7
2.3.1	Using two twisted pairs of CAT5 cable	7
2.3.2	Using additional twisted pairs of CAT5 cable.....	8
3	Extending the range of the Keypad Bus: RS-485 and Fibre Optic	9
4	Using RS-485 signals.....	10
4.1	RS-485 Wiring Limitations	10
4.2	Network Layout.....	10
4.3	Wiring Guide.....	11
4.3.1	Using one twisted pair of CAT5 cable.....	11
4.3.2	Using additional twisted pairs of CAT5 cable.....	12
4.3.3	Using an external power supply	13
4.3.4	Configuring PAE100 with full isolation	13
5	Using Fibre Optic signals	14
5.1	Fibre Optic Wiring Limitations	14
5.2	Network Layout.....	14
5.3	Wiring Guide.....	15
5.3.1	LS422 to Keypad Bus	15
5.3.2	LS422 to LS422	16
5.3.3	Using an external power supply	16

1 Introducing the Keypad Bus

The JVA Z Series has a variety of communications methods and protocols. The basic inbuilt method is a wired low speed serial data protocol called the Keypad Bus. As the name suggests this is a connection from the energisers to the keypad. The Keypad Bus, however, is also used to link energisers together in a group, and to pass data to and from other systems using a variety of adaptors.

The communications across the Keypad Bus allow:

- Energisers to be controlled by a LCD keypad;
- Linking of energisers to operate in Group Mode;
- Linking up to higher level protocols such as TCP/IP;
- I/O expander devices, and;
- Perimeter Patrol to monitor and control energisers through the use of a Keypad Bus adaptor connected to the host computer via RS-232, RS485, USB or Ethernet.

Keypad Bus facts:

- Z series devices (energisers and monitors) are identified by ID, as set in option 26. The maximum number of devices excluding keypads that can be connected to the Keypad Bus is 15.
- ID 1 is reserved for the group master. Usually a Z series energiser, but may also be a TCP/IP adaptor (PAE212).
- Z series devices are usually factory set (default) to ID 0, meaning it is not in a group. In order to operate in a group an ID needs to be set using a keypad.
- Up to 4 LCD keypads may be connected to the Keypad Bus. Keypad addresses range from 1 to 7 and do not occupy the same ID space as energisers.
- Keypad address 2 is reserved for a PC running Perimeter Patrol.

NOTE: If multiple Energisers or Zone Monitors are connected via the Keypad Bus, or if an Ethernet Adapter or Ethernet IO Board is connected to the bus, then the connected devices must all be programmed for Group Mode operation. Refer to the Z Series OEM Technical Manual for more information on configuring devices for Group Mode.

At this stage in order to set a group ID a keypad must be plugged directly into a device, with no other device on the bus at that time.

1.1 Keypad Bus Wires

The Keypad Data bus consists of three wires: Ground (GND), Data (DAT), and Power (12V).

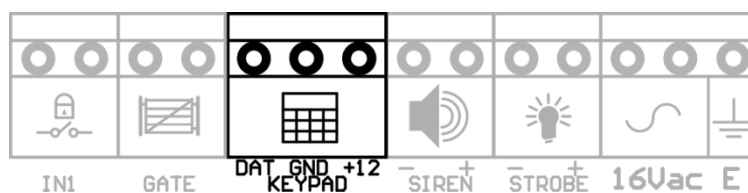

Figure 1: Keypad Bus connections

The GND and DAT wires are required for all devices on the Keypad Bus. Note that the GND wire on the Keypad Bus should only be connected to the GND point on other Keypad Bus connections. No attempt should be made to connect this point to an earth electrode, to the Fence Earth, or to the 'ground' connection of other circuits.

The +12V wire allows self powered devices (Energisers, Zone Monitors and Ethernet IO Boards) to supply power to the other devices such as Keypads. When linking energisers in a group the +12V should not be connected between each energiser, only the Dat and Gnd is required. The +12V line is only required to be connected to devices that are to be powered off the bus, such as LCD Keypads.

If the number of devices trying to draw power from the Keypad Bus is too large, then an external 12V power supply may be needed to power these devices. Ideally, the total current drawn from the Keypad Bus should not exceed 100mA.

1.2 Keypad Bus devices

Table 1 – Specifications of various Keypad Bus devices

Name	Part Number	Type	Power	Comment
Z11	PTE1046	Energiser	External	
Z13	PTE1041	Energiser	External	
Z14	PTE1040	Energiser	External	
Z14R	PTE1042	Energiser	External	
Z18	PTE1045	Energiser	External	
Z114	PTE1044	Energiser	External	
Z25	PTE1047	Energiser	External	
Z28	PTE1043	Energiser	External	
ZM1	PTE0202	Zone Monitor	External	
ZM20	PTE0213	Zone Monitor	External	
LCD Keypad	PTE0210	Keypad	Bus	Use Keypad ID 4-7 if more than one LCD Keypad present
RS232 Adapter	PAE051	Keypad Bus Adapter	Bus	Obsolete; use PAE223 USB Adapter
RS485 Adapter	PAE100	Keypad Bus Adapter	Bus	
USB Adapter	PAE223	Keypad Bus Adapter	Bus	
Keypad Bus Repeater	PAE221	Keypad Bus Adapter	Bus	Requires +12V wired to each side of the adapter
Perimeter Patrol Interface	PAE212	Keypad Bus Adapter	External	Locked to Group ID 1
Webserver	PAE225	Keypad Bus Adapter	External	Uses Keypad ID 2
GPIO Board	PAE222	IO Board	Bus	
Ethernet GPIO Board	PAE224	Keypad Bus Adapter/ IO Board	External	Locked to Group ID 1
Z Series GSM Adapter	PAE218	Keypad Bus Adapter	Bus	

1.3 Baud rate

At this stage most devices are limited to 2400 baud. Over time devices will be upgraded to enable the use of higher baud rates. The Keypad, for example is able to extend to 9600. All devices on the Keypad Bus must be set to the same baud rate. If in doubt, return the device to default, this is usually accomplished by removing J4 and cycling power.

1.4 Keypad Bus Mk2

New energisers are beginning to feature an upgraded version of the Keypad Bus protocol, Keypad Bus Mk2. This revision allows Mk2 devices to benefit from longer cable distances, higher baud rates, and increased keypad interaction with the energisers.

Keypad Bus Mk2 is also backwards compatible with the original Keypad Bus, allowing older devices to be used in Mk2 networks (but without the benefits that Mk2 devices offer).

Mk2 devices can be identified by a “2” next to the keypad symbol (below the keypad bus connector).

2 Keypad Bus Installation

2.1 Keypad Bus Wiring Limitations

The total combined length of CAT5 cable on the Keypad Bus should not exceed the value specified in Table 2. If this length is exceeded, then the Keypad Bus may not function correctly.

Table 2 – Maximum Wire Lengths for Keypad Bus

Wiring	Recommended Max. Total Length
One twisted pair CAT5	100m
Two twisted pairs CAT5	150m
Three twisted pairs CAT5	200m

If all devices on the Keypad Bus are Keypad Bus Mk2 devices, then the total combined length of CAT5 on the Keypad Bus Mk2 network can be extended to the lengths specified in Table 3 – Maximum Wire Lengths for Keypad Bus Mk2

Table 3 – Maximum Wire Lengths for Keypad Bus Mk2

Wiring	Recommended Max. Total Length
One twisted pair CAT5	1000m
Two twisted pairs CAT5	1250m
Three twisted pairs CAT5	1500m

The wire length between an Energiser, Zone Monitor or Ethernet IO Board supplying power to the Keypad Bus, and any devices drawing power from the Keypad Bus should not exceed 50m. Ideally, these connections should be as short as possible.

Note: CAT5 cable is recommended for all Keypad Bus connections. The maximum wire distances specified above are for CAT5 cable; other types of cabling will have different parameters, so these distances will be different.

2.2 Network Layout

When installing a Keypad Bus, there are many ways in which to lay out cable such that each device is connected to the network. To ensure that the network operates reliably, the network should be designed as outlined in this section.

Because of the physical nature of the Keypad Bus, large loops in the network layout like the example in Figure 2 should be avoided. These loops allow the cable to pick up noise from the surrounding environment, disrupting communications.

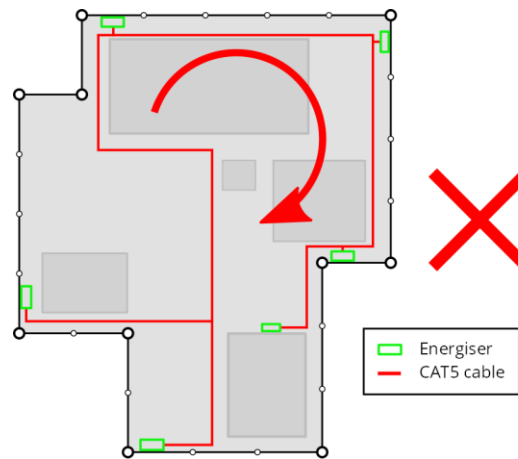

Figure 2: Keypad Bus network configuration showing a loop

Also, as mentioned above, the distance between devices drawing power from the Keypad Bus and the device supplying power to the Keypad Bus should be kept to a minimum.

Instead, it is recommended that a 'star' or 'bus' configuration be used for the network. An example of each of these is shown below in Figure 3 and Figure 4 respectively.

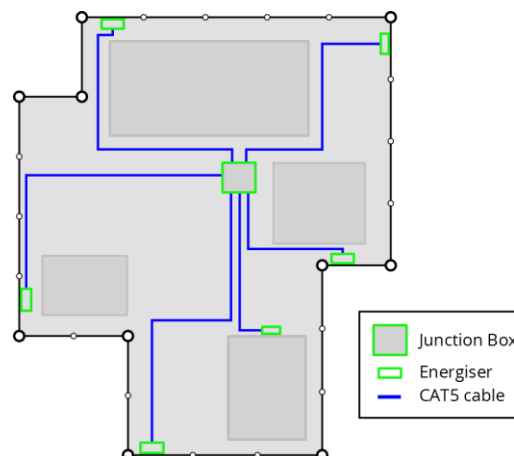

Figure 3: Keypad Bus network in a 'star' configuration

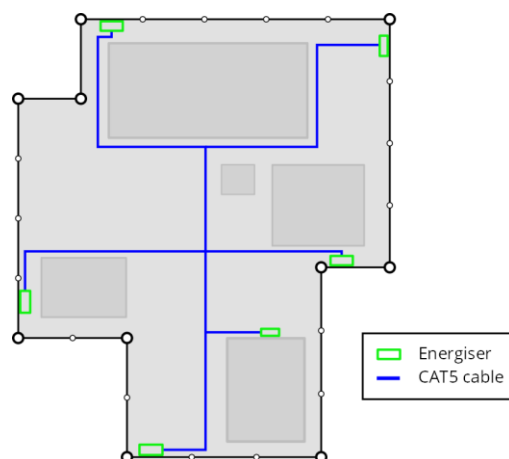

Figure 4: Keypad Bus network in a 'bus' configuration

2.3 Wiring Guide

While there are many different ways to wire a Keypad Bus, the use of CAT5 cable along with the wiring methods outlined below is recommended to ensure reliable operation of the Keypad Bus, especially over large distances.

2.3.1 Using two twisted pairs of CAT5 cable

There are four twisted pairs of wires contained within a CAT5 cable. Each 'twisted pair' consists of two wires marked with the same colour (one solid and one striped), physically twisted together within the CAT5 cable.

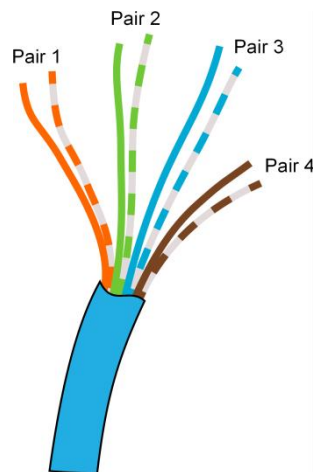

Figure 5: Identifying pairs in a CAT5 cable

This wiring method uses only two of these four pairs, allowing the other two pairs to be used to wire other devices if required. If the Power line is not required (i.e. if only Externally powered devices are connected to the Keypad Bus), then that twisted pair can be omitted from the Keypad Bus wiring.

Note that the colour of the pair used does not matter, as long as the matching pair is used at the other end.

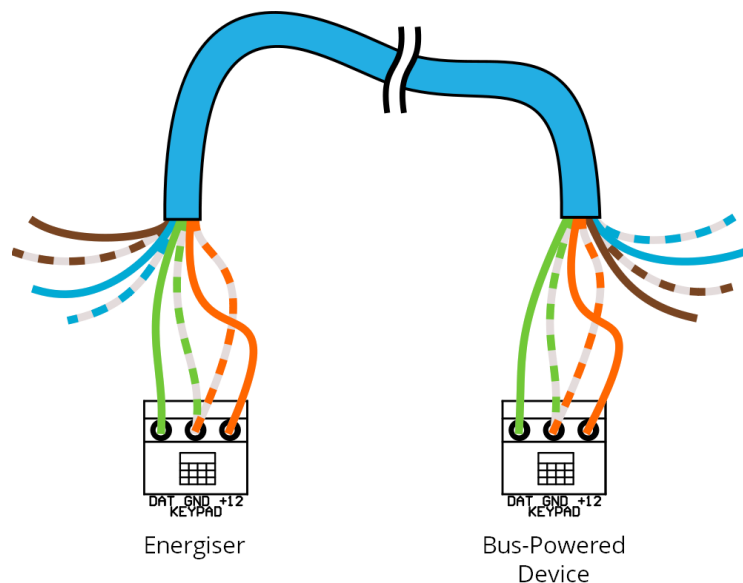

Figure 6: Wiring a Keypad Bus using CAT5 cable

2.3.2 Using additional twisted pairs of CAT5 cable

If there are unused twisted pairs within the CAT5 cable, then they may be doubled up to the Data and Ground twisted pair to increase the maximum allowable length of the keypad bus. Figure 7 shows this method.

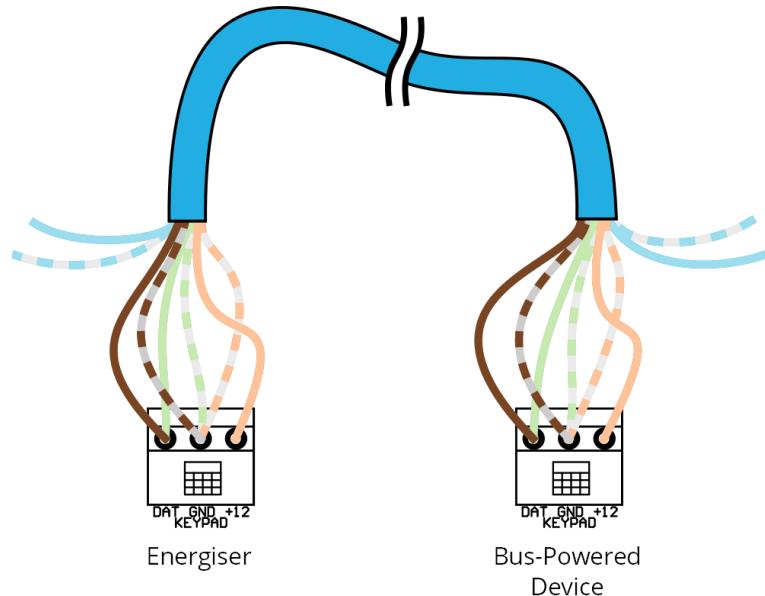

Figure 7: Doubling up wire pairs on the Keypad Bus

When doubling up wire pairs, make sure that the striped wires are all joined together, and the coloured wires are all joined together, as shown in Figure 8. Do not mix and match the coloured and striped wires.

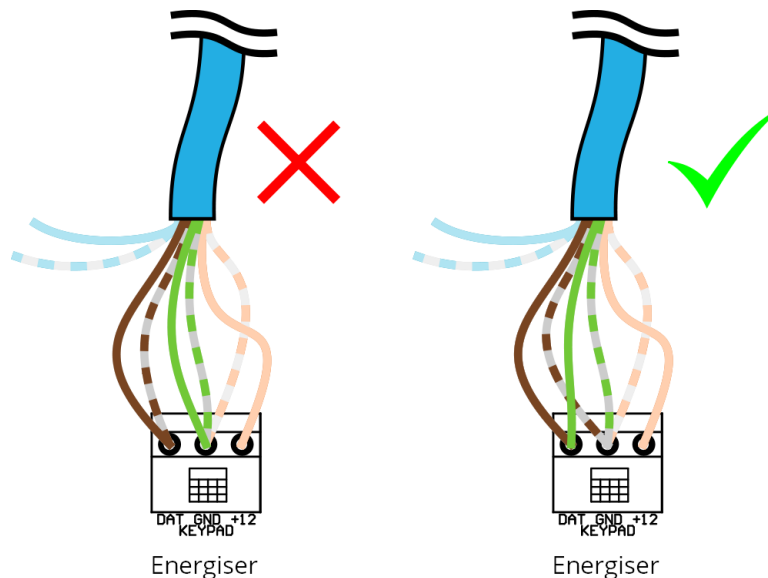

Figure 8: Correct doubling of wire pairs

This doubling technique may also be used to double up the +12V line to provide power to bus powered devices that mounted a long distance from the device supplying power to the Keypad Bus. As with the data line, do not mix the coloured and striped wires.

3 Extending the range of the Keypad Bus: RS-485 and Fibre Optic

In some applications, it may be required to install a Keypad Bus with a total cable length longer than those specified in Table 2. To do this, the Keypad Bus communications must be converted into a signal that is able to travel the longer distances.

At this time, there are two alternative signals for the Keypad Bus: RS-485 and Fibre Optic communication. The sections below describe the use of each of these signals.

Since JVA security products only support communication through Keypad Bus signals, the use of these alternative signals requires a special adapter to be attached to each JVA security product: the PAE100 Keypad Bus to RS-485 adapter, or the LS422 Keypad Bus to Fibre Optic Transceiver.

4 Using RS-485 signals

4.1 RS-485 Wiring Limitations

The total combined length of CAT5 cable on the Keypad Bus should not exceed the value specified in Table 4. If this length is exceeded, then the Keypad Bus may not function correctly.

Table 4 – Maximum Wire Lengths for Keypad Bus over RS-485

Wiring	Recommended Max. Total Length
One twisted pair CAT5	200m
Two twisted pairs CAT5	250m
Three twisted pairs CAT5	300m

Because the RS-485 bus does not provide power to its devices, the PAE100 Keypad Bus to RS-485 adapters must be powered from the +12V wire of the Keypad Bus. If the device that the adapter is connected to is not an Energiser, Zone Monitor or Ethernet IO Board, then an external 12V regulated DC power supply must be wired on to the Keypad Bus to allow the device and the adapter to operate. See Section 4.3.3: *Using an external power supply* for details on how to wire an external power supply into the Keypad Bus.

Note: CAT5 cable is recommended for all RS-485 connections. The maximum wire distances specified above are for CAT5 cable; other types of cabling will have different parameters, so these distances will be different.

4.2 Network Layout

As with the Keypad Bus, large loops in the network layout should be avoided. These loops allow the cable to pick up noise from the surrounding environment, possibly disrupting communications.

Instead, it is recommended that a 'star' or 'bus' configuration be used for the network. For detailed examples, please see Section 2.2: *Network Layout* on page 5.

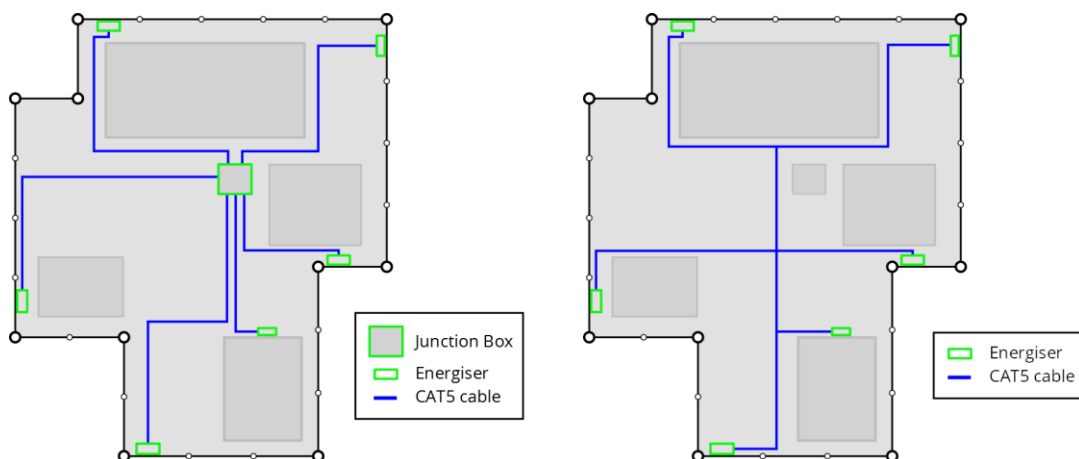

Figure 9: Keypad Bus network in 'star' or 'bus' configuration

4.3 Wiring Guide

For wiring long RS-485 cables, CAT5 cable is recommended. Any cable used must be twisted pair, and should have impedance specifications equal to or better than CAT5 cable.

4.3.1 Using one twisted pair of CAT5 cable

There are four twisted pairs of wires contained within a CAT5 cable. Each 'twisted pair' consists of two wires marked with the same colour (one solid and one striped), physically twisted together within the CAT5 cable.

This wiring method uses only one of these four pairs, allowing the other three pairs to be used to wire other devices if required.

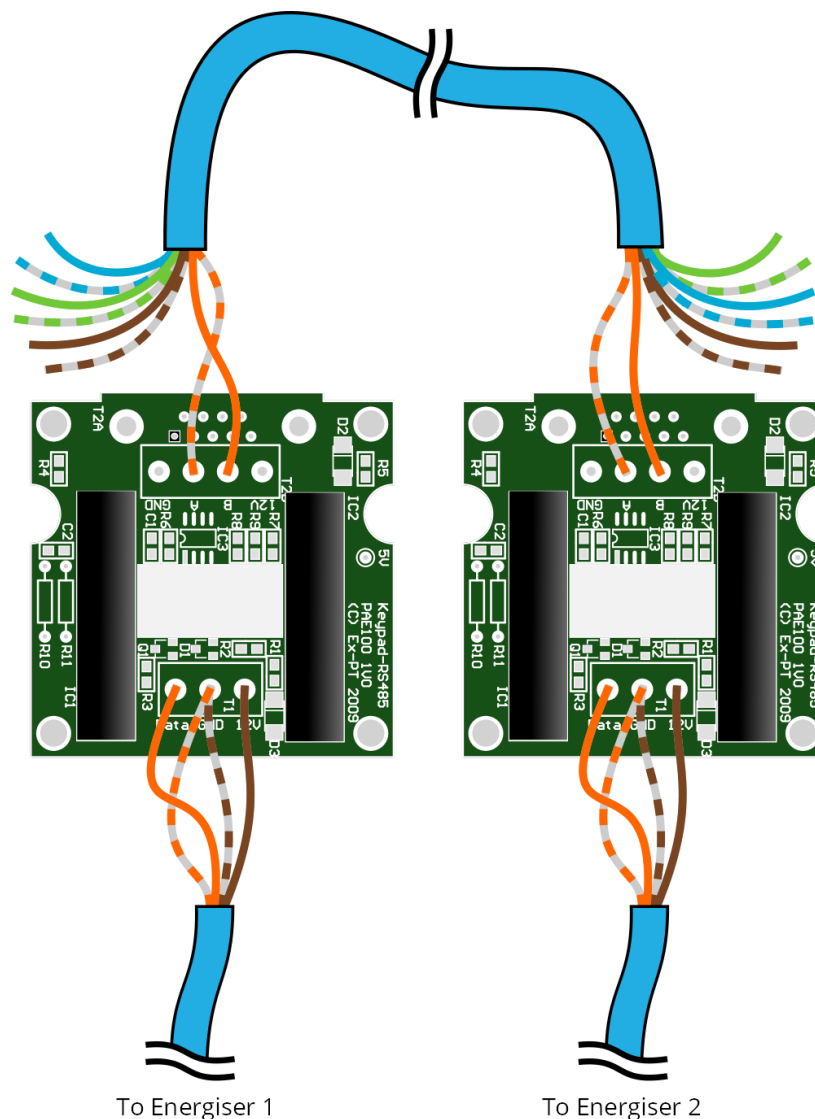

Figure 10: Wiring an RS485 network using CAT5 cable

In addition, a 120 ohm resistor should be fitted between the two wires (A and B), preferably far away from the master energiser. For 'star' network configurations, the best place to put this resistor is the central junction box; for 'bus' network configurations, the best place to put this resistor is at the RS-485 wire junction that is furthest from the master energiser.

4.3.2 Using additional twisted pairs of CAT5 cable

If there are unused twisted pairs within the CAT5 cable, then they may be doubled up to the Data and Ground twisted pair to increase the maximum allowable length of the RS-485 bus. Figure 11 shows this method.

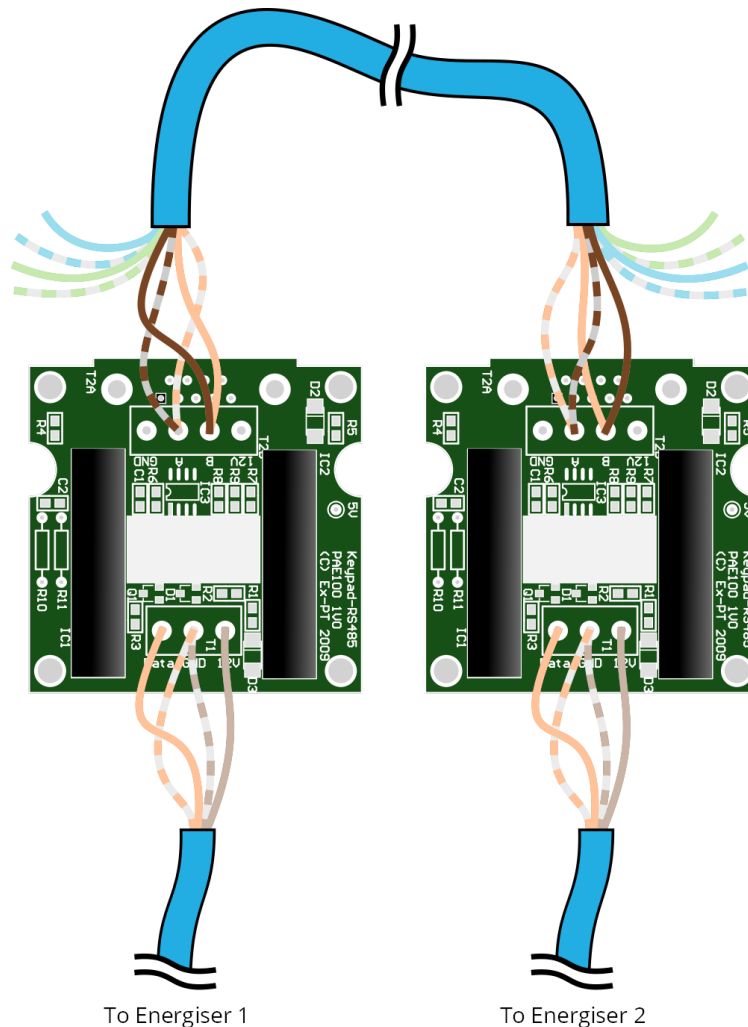

Figure 11: Doubling up wire pairs on an RS485 network

When doubling up pairs, make sure that the striped wires are all joined together, and the coloured wires are all joined together, as shown in Figure 12. Do not mix and match the coloured and striped wires.

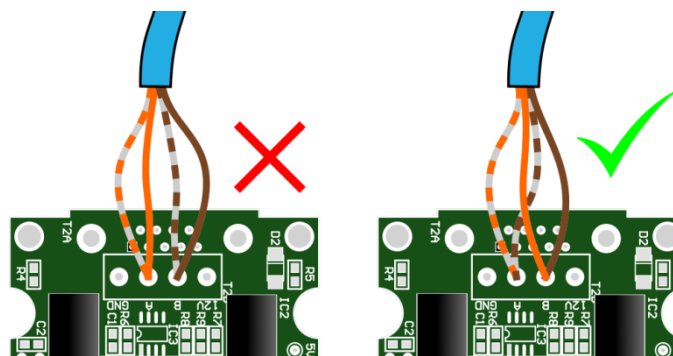

Figure 12: Correct doubling of pairs

4.3.3 Using an external power supply

If the device that the PAE100 Keypad Bus to RS-485 adapter is connected to is not an externally powered device, then an external 12V regulated DC power supply must be wired on to the Keypad Bus to allow the device and the adapter to operate. An unregulated DC power supply cannot be used.

Figure 13 shows how to wire a 12V regulated DC power supply into the Keypad Bus to power both the adapter and the device it is connected to, in this case a PAE223 USB to Keypad Bus adapter.

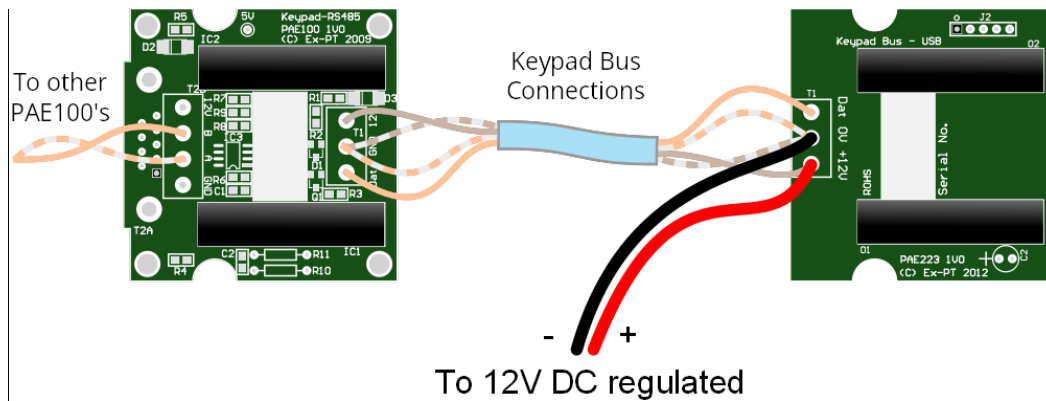

Figure 13: Using an external power supply with the PAE100

4.3.4 Configuring PAE100 with full isolation

In high-noise environments, it may be beneficial to use the PAE100 with full isolation. This requires the use of an external 12V regulated DC power supply to power the RS-485 communications.

To operate the PAE100 with full isolation, first remove R10 and R11 from the board by snipping the legs with side cutters, and then connect the 12V regulated DC power supply to the "12V" and "GND" terminals on the RS-485 screw terminal, as shown in Figure 14. Note that the Keypad Bus screw terminal must still be powered from an Energiser, Zone Monitor or Ethernet IO Board in order to operate correctly.

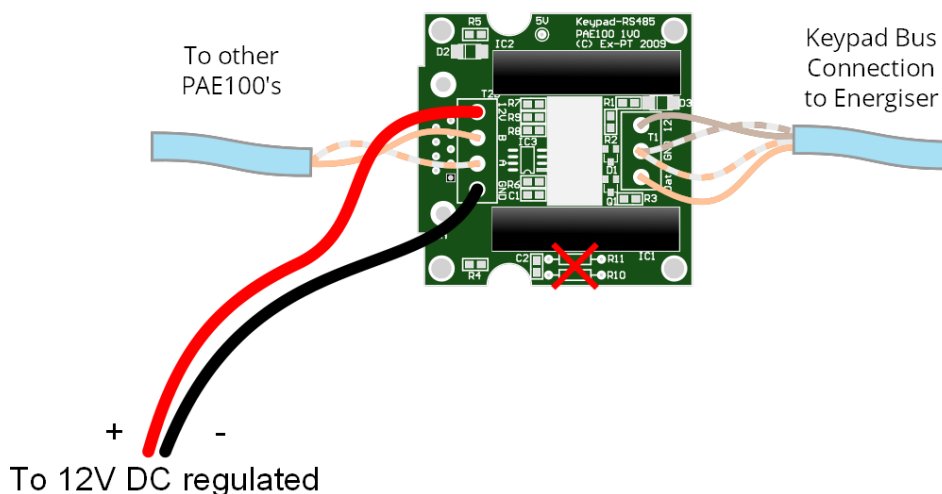

Figure 14: Wiring configuration to use PAE100 with full isolation

5 Using Fibre Optic signals

5.1 Fibre Optic Wiring Limitations

The length of Fibre Optic cable joining two LS422 Keypad Bus to Fibre Optic Transceivers should not exceed the value specified in Table 5. If this length is exceeded, then the communications may not function correctly.

Because the devices are wired in a ring configuration, the total amount of Fibre Optic cable in the entire network can exceed this value, as long as the length of each Fibre Optic cable joining two LS422's is kept below 3000m.

Table 5 – Maximum Wire Lengths for Keypad Bus over Fibre Optic

Wiring	Max. Single Length
Fibre Optic cable between two LS422's	3000m

Because the Fibre Optic cable bus does not provide power to its devices, the LS422 must be powered from the +12V wire of the Keypad Bus. If the device that the adapter is connected to is not an Energiser, Zone Monitor or Ethernet IO Board, then an external 12V regulated DC power supply must be wired to the adapter and the Keypad Bus to allow the device and the adapter to operate. See Section 5.3.3: *Using an external power supply* for details on how to wire an external power supply into the LS422 and the Keypad Bus.

5.2 Network Layout

When installing the Fibre Optic network, the adapters need to be connected in a 'ring' configuration for them to work. An example of a ring configuration is shown in Figure 15.

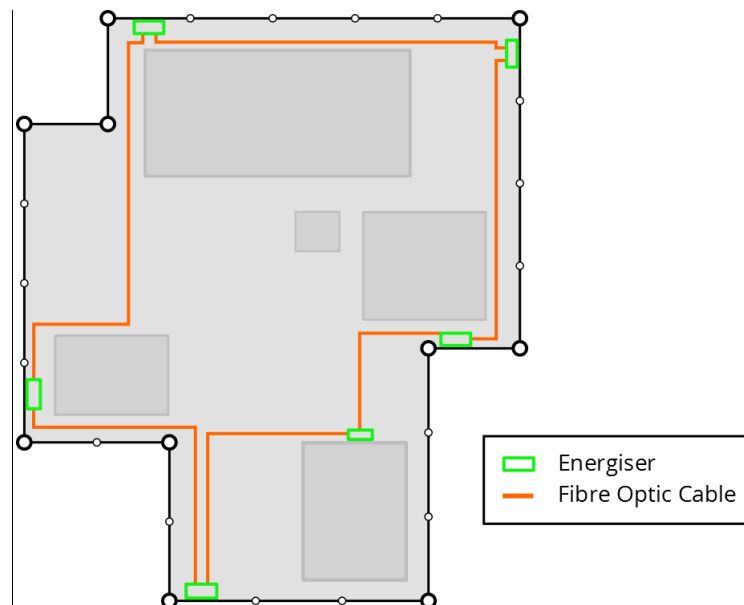

Figure 15: Fibre Optic network in a 'ring' configuration

At some sites, the wiring design may have specified cables to be routed through a central junction box (this is known as a 'star' configuration). In this case, the cables should be connected as shown in Figure 16.

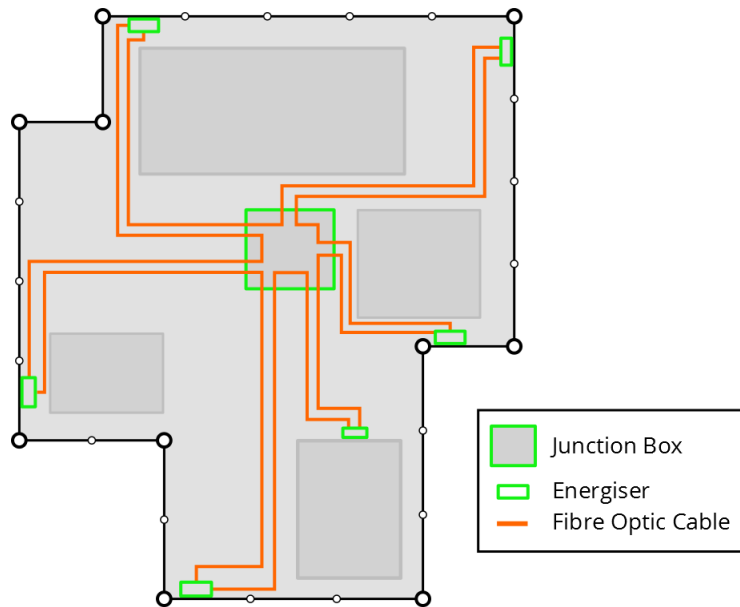

Figure 16: Fibre Optic network in a 'star' configuration

5.3 Wiring Guide

5.3.1 LS422 to Keypad Bus

The LS422 should be wired to the Keypad Bus as shown in Figure 17. The LS422 must be powered by the Keypad Bus in order to operate. The length of the cables between the LS422 and the Keypad Bus device should be kept as short as possible.

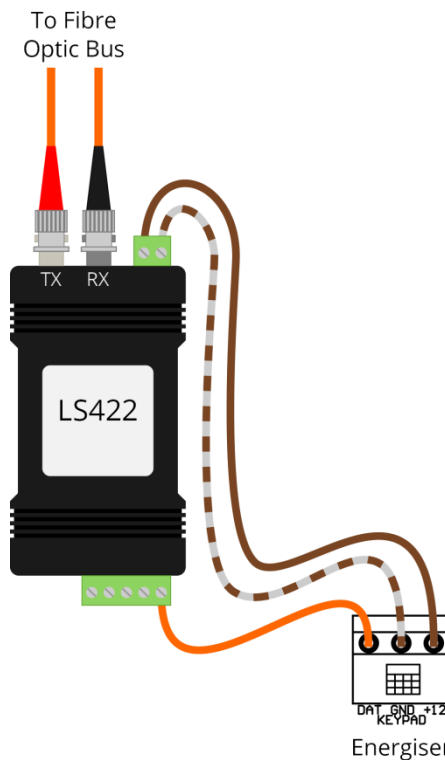

Figure 17: Wiring the LS422 to the Keypad Bus

5.3.2 LS422 to LS422

The LS422s must be wired together in a loop, with the "TX" Fibre Optic port of the first device connected to the "RX" Fibre Optic port of the next, as shown in Figure 18.

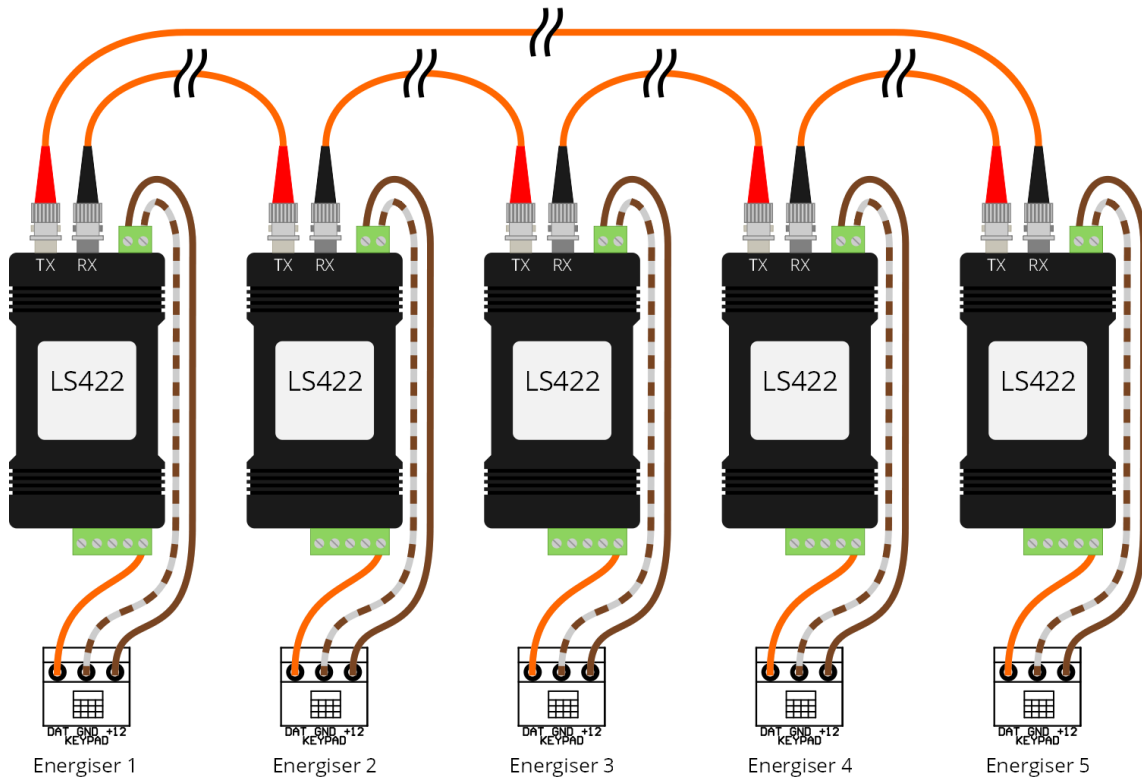

Figure 18: Wiring LS422's together into a network

5.3.3 Using an external power supply

If the device that the LS422 Keypad Bus to Fibre Optic Transceiver is connected to is not an Energiser, Zone Monitor or Ethernet IO Board, then an external 12V regulated DC power supply must be wired on to the Keypad Bus to allow the device and the adapter to operate. An unregulated DC power supply cannot be used.

Figure 19 shows how to wire a 12V regulated DC power supply into the Keypad Bus to power both the adapter and the device it is connected to, in this case a PAE223 USB to Keypad Bus adapter.

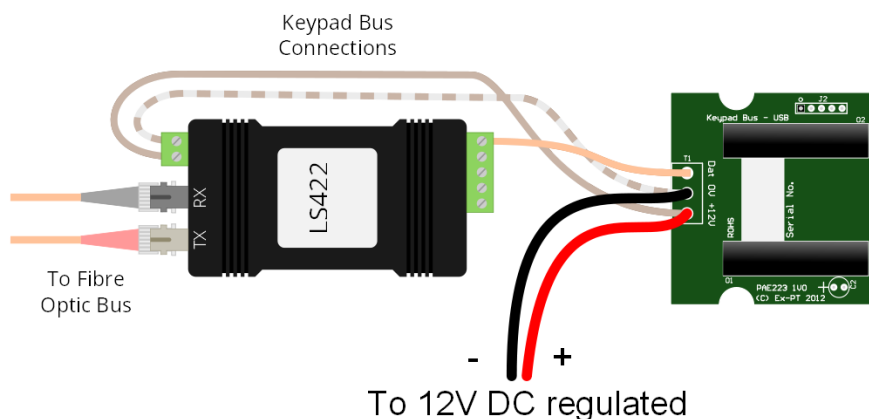

Figure 19: Using an external power supply with the LS422