

Installation Manual FEA20M ELECTRIC STRIKE

PRODUCT

FEA20M is a monitored Electric Strike to replace the old PADDE EA Electric Strike. The strike is a modified version of the FSH FES20M product. A small modification on the frame has to be made to replace existing old PADDE EA strikes.

WIRING

Connect the wiring according to list below:

| | | | |
|---------------------------------|--|--|---------------------------|
| Power Input | Multi Voltage 11-30VDC | 12 VDC – current 220 mA | 24 VDC – current 110 mA |
| Wire output | Red (+) | Black (-) | |
| LSS (Lock Status Sensor) | Black (Common) | Yellow (NO-PTO); (NC-PTL) | Green (NC- PTO); (NO-PTL) |
| DSS(Door Status Sensor) | Black (Common) | Blue (NO) | Orange (NC) |
| Sensor Output | LSS Sensor Output 3 A, 125 VAC; 2 A, 30 VDC. | DSS Sensor Output 3 A, 125 VAC; 2 A, 30 VDC. | |

NOTE

FEA20M Series Electric Strike factory setting is Power to Lock (PTL).

The control circuit for the door strike is protected against reverse polarity connection. No additional diode protection required.

The product must not be installed in applications where it will be exposed to wind and weather (external gates etc.).

PRODUCT DIMENSIONS

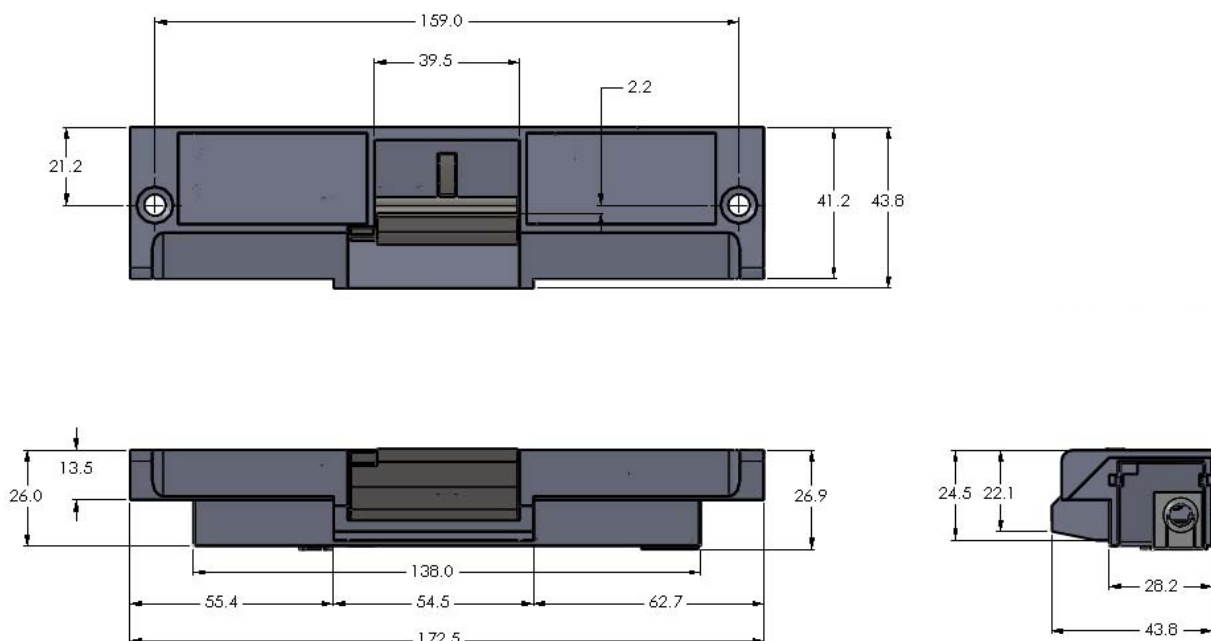

INSTALLATION

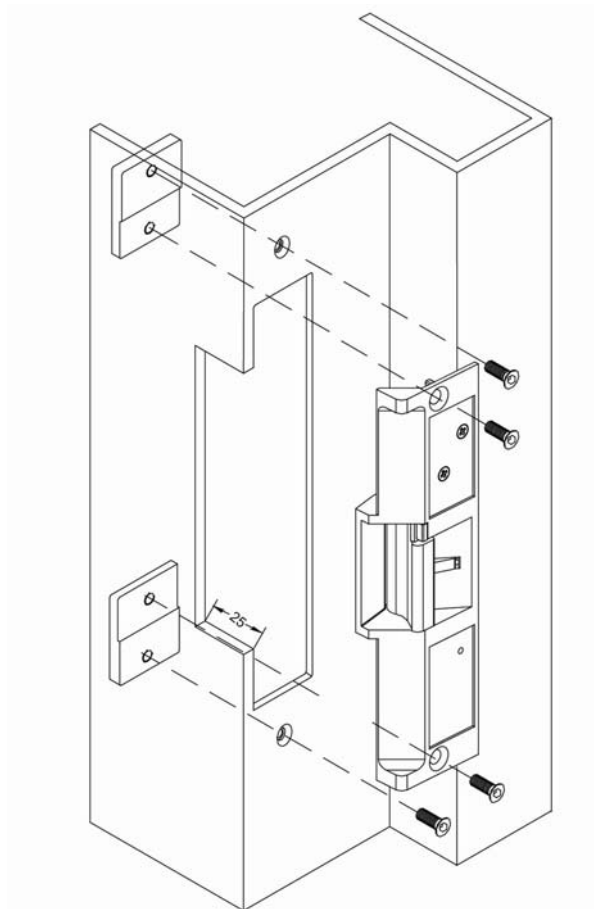

CUT-OUT DIMENSIONS AND MOUNTING TEMPLATE (not to scale)

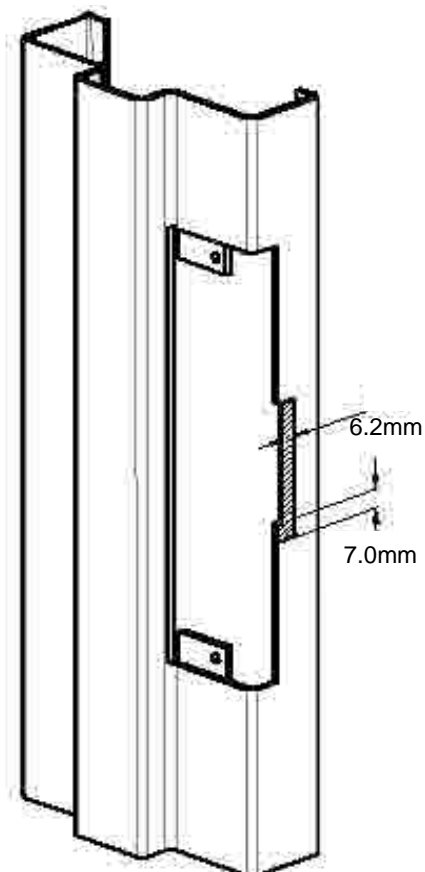

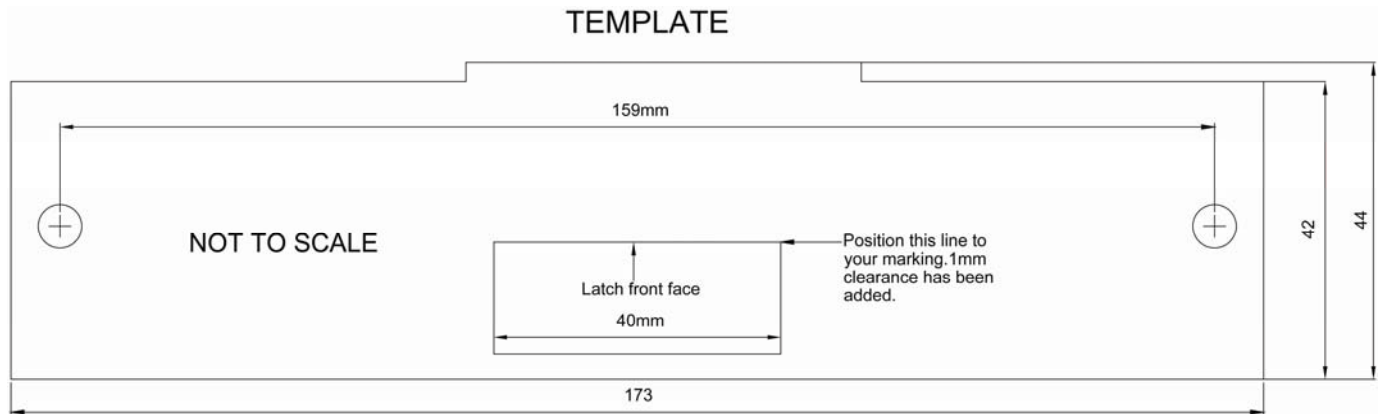

These dimensions have a tolerance of +0.8mm/-0



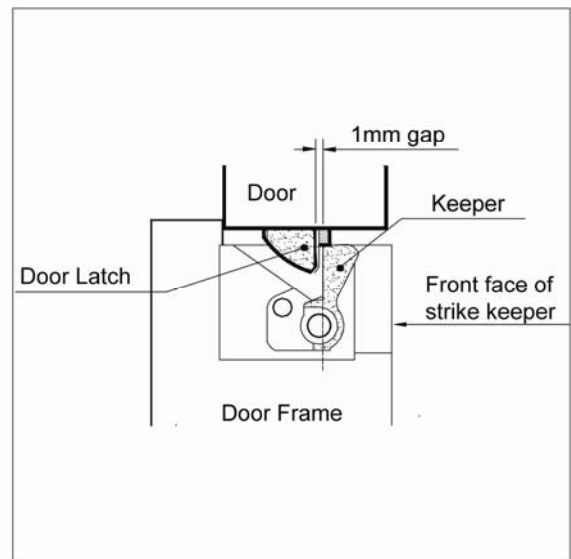
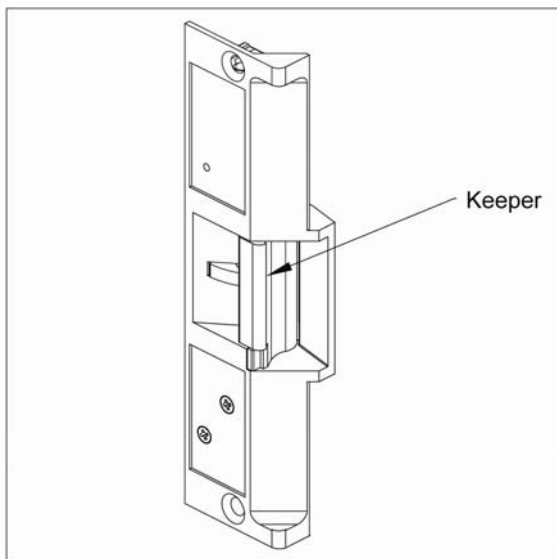



POSITION OF DOOR LATCH



As drawn in the diagrams, there should be a 1mm gap between the door latch and the front face of the strike keeper, preventing the door from creating back pressure on the strike keeper when the door is closed.







FIELD SELECTION

PROCEDURES TO CONVERT PTO (POWER TO OPEN) TO PTL (POWER TO LOCK)

- | | | | |
|----------|--|----------|---|
| 1 | Remove the rubber cap to expose the capstan wheel. | 1 |  |
| 2 | Slacken both of the capstan release screws two full revolutions, DO NOT REMOVE. | 2 |  |
| 3 | Remove the sticker from the cover end opening hole. | 3 |  |
| 4 | Insert the "tool pin" through the cover end opening hole and push down the solenoid. Hold it in position and at the same time insert the "tool" thru the cover plate opening hole and turn the capstan wheel in the direction of the keeper to the stop. | 4 |  |
| 5 | The strike is now in the Power to Lock mode. | 5 |  |
| 6 | Tighten the two capstan releasing screws replace the rubber cap. | 6 |  |
| 7 | Replace the sticker after changing over locking function. | 7 |  |

FIELD SELECTION

PROCEDURES TO CONVERT PTL (POWER TO LOCK) TO PTO (POWER TO OPEN)

- | | | | |
|----------|---|----------|---|
| 1 | Remove the rubber cap to expose the capstan wheel. | 1 |  |
| 2 | Slacken both of the capstan release screws two full revolutions, DO NOT REMOVE. | 2 |  |
| 3 | Remove the sticker from the cover end opening hole. | 3 |  |
| 4 | Insert the "tool pin" through the cover end opening hole and push down the solenoid. Hold it in position and at the same time insert the "tool" thru the cover plate opening hole and turn the capstan wheel in the direction of the release screw to the stop. | 4 |  |
| 5 | The strike is now in the Power to Open mode. | 5 |  |
| 6 | Tighten the two capstan releasing screws and replace the rubber cap. | 6 |  |
| 7 | Replace the sticker after changing over locking function. | 7 |  |

WARRANTY

FSH Fire & Security Hardware Pty Ltd (FSH) warrants this product against faulty workmanship and materials for a period of 5 years. The warranty does not cover fair wear and tear. The product must be installed according to FSH specifications.