



INDUSTRIAL SLIDING GATE OPERATOR

Company Profile

Centurion Systems (Pty) Ltd, South Africa, has been manufacturing automatic gate systems since 1986, and is committed to providing reliable, cost effective solutions in the field of gate and access automation.

We offer a diverse range of products including gate motors, GSM-based products, garage door motors, remote controls, keypads, traffic barriers, proximity access control and intercom systems.

Our products are developed by an in-house team of talented engineers that are constantly researching new and innovative technologies to improve our existing products and expand our product range.

Our production facility in Johannesburg is ISO:9001 quality assurance certified, and all our products are manufactured to the highest level of quality with a 100% test to specification.

Through a team of dedicated technicians and sales personnel, together with a fully fledged in-house training facility, we are committed to providing unmatched service to our customers and support for our products.

A worldwide network of distributors and installers ensure that our products remain The Automatic Choice in access automation .

Further information is available on our website www.centsys.com.au



Centurion Systems (Pty) Ltd reserves the right to make changes to the products described in this document without notice and without obligation of Centurion Systems (Pty) Ltd to notify any persons of any such revisions or changes. Additionally, Centurion Systems (Pty) Ltd makes no representations or warranties with respect to this document.

No part of this document may be copied, stored in a retrieval system or transmitted in any form or by any means electronic, mechanical, optical or photographic, without the express prior written consent of Centurion Systems (Pty) Ltd.

Important Safety Instructions

ATTENTION

To ensure the safety of people, it is important that you read all the following instructions. Incorrect installation or incorrect use of the product could cause serious harm to people.

The installer, being either professional or DIY, is the last person on the site that can ensure that the operator is safely installed, and that the whole system can be operated safely.

WARNINGS FOR THE INSTALLER

1. CAREFULLY READ AND FOLLOW ALL INSTRUCTIONS before beginning to install the product.
2. This appliance is not intended for use by persons (including children) with reduced physical, sensory or mental capabilities, or lack of experience and knowledge, unless they have been given supervision or instruction concerning use of the appliance* by a person responsible for their safety.
3. All installation, repair, and service work to this product must be done by a suitably qualified person.
4. Do not activate your gate opener unless you can see it and can determine that its area of travel is clear of people, pets, or other obstructions.
5. NO ONE MAY CROSS THE PATH OF A MOVING GATE. Always keep people and objects away from the gate and its area of travel.
6. NEVER LET CHILDREN OPERATE OR PLAY WITH THE GATE CONTROLS, and do not allow children or pets near the gate area.
7. Secure all easily accessed gate opener controls in order to prevent unauthorized use of the gate.
8. Do not in any way modify the components of the automated system.
9. Do not install the equipment in an explosive atmosphere: the presence of inflammable gas or fumes is a serious danger to safety.
10. Before attempting any work on the system, cut electrical power and disconnect the batteries.
11. The mains power supply of the automated system must be fitted with an all-pole switch with contact opening distance of 3mm or greater. Use of a 5A thermal breaker with all-pole circuit break is recommended.
12. Make sure that an earth leakage circuit breaker with a threshold of 30mA is fitted upstream of the system.
13. Never short circuit the battery and do not try to recharge the batteries with power supply units other than that supplied with the product, or by Centurion Systems (Pty) Ltd.
14. Make sure that the earthing system is correctly constructed, and that all metal parts of the system are suitably earthed.
15. Safety devices must be fitted to the installation to guard against mechanical movement risks such as crushing, dragging and shearing.
16. It is recommended that at least one warning indicator light be fitted to every system.
17. Always fit the warning signs visibly to the inside and outside of the gate.
18. The installer must explain and demonstrate the manual operation of the gate in case of an emergency, and must hand the User/Warnings guide over to the user.
19. Explain these safety instructions to all persons authorized to use this gate, and be sure that they understand the hazards associated with automated gates.
20. Do not leave packing materials (plastic, polystyrene, etc.) within reach of children as such materials are potential sources of danger.
21. Dispose of all waste products like packaging materials, worn out batteries, etc, according to local regulations.
22. Always check the obstruction detection system, and safety devices for correct operation.
23. Centurion Systems (Pty) Ltd does not accept any liability caused by improper use of the product, or for use other than that for which the automated system was intended.
24. This product was designed and built strictly for the use indicated in this documentation. Any other use, not expressly indicated here, could compromise the good condition/operation of the product and/or be a source of danger.
24. Everything not expressly specified in these instructions is not permitted.

**Appliance should be product described in manual*

WARNING



**MOVING GATE CAN CAUSE
SERIOUS INJURY OR DEATH**
**KEEP CLEAR. GATE MAY MOVE AT
ANY TIME. DO NOT ALLOW
CHILDREN TO PLAY IN AREA OR
OPERATE GATE .**

These abbreviated instructions are for the experienced installer who needs a checklist to get a standard installation up and running in the minimum of time.

Detailed installation features and functions are referred to later in this manual.

Mechanical Setup

Action		
Step 1	Gather required tools and equipment	Page 13
Step 2	Heed necessary site considerations	Page 14-17
Step 3	Check cabling requirements	Page 18
Step 4	Secure foundation plate	Page 19-21
Step 5	Introduce oil	Page 22
Step 6	Mount gearbox	Page 23
Step 6 (chain)	Mount chain drive hardware (Optional)	Page 26
Step 7	Mount rack	Page 24
Step 7 (chain)	Mount chain (Optional)	Page 27
Step 8	Mount origin marker	Page 28
Step 9	Test endstops	Page 15

Electrical Setup

Action		
Step 1	Connect all wiring:	Page 30
Step 2	Get into programming mode: Fit the SET link. Briefly depress the reset button.	Page 30
Step 3	Set the gate limits: Press and hold TEST, release after one flash of L1. Press and hold TEST, release after one or two flashes of STATUS. <i>(one flash = gate opens to the RIGHT. two flashes = gate opens to the LEFT).</i>	Page 30
Step 4	Set additional features: (If required)	Page 32
Step 5	Exit programming mode: Remove the SET link.	
Step 6	Perform installation hand over	Page 48

General Description

The A10 is a heavy duty sliding gate operator designed to open and close sliding gates.

In cases where chain, (as opposed to toothed rack) drive is required, an optional chain drive kit is available.

The key to the A10's outstanding torque and duty cycle lies in the 3-phase induction motor and electronic inverter that form the heart of the system. Single-phase 220-240VAC power is converted into variable frequency 3-phase power, allowing electronically controlled soft starting and stopping of the motor.

An optional DC converter is available, containing back up batteries and UPS type backup circuits. This enables the A10 to continue operating for a limited period in the event of a power failure.

In order to cater for high duty cycle installations, the A10 Endurance model is offered. This model utilizes a continuously powered cooling fan, whilst the basic model utilizes the motor's standard shaft driven cooling fan. The A10 heavyweight model is similar to the Endurance model with the exception of the 17 tooth output pinion. It is suitable for sites with a gate mass up to 2000kg

Gate travel limits are managed by an opto-electronic system, comprising a gate mounted origin marker and an internal rotary encoder. This system yields precise and repeatable control over gate position.

Advanced features of the CP201 logic controller include:-

- Automated setup of gate endpoints (limits).
- Fail safe collision detection and auto reverse (adjustable sensitivity).
- Smoothed start/stop (ramp up/down).
- Multiple operational modes.
- Selectable, adjustable autoclosing.
- Pedestrian (partial) opening.
- Positive Close Mode.
- Safety input for sensitive edge/safety beam/inductive loop.
- Advanced lightning/surge protection.
- Timed courtesy light output.
- Multiple preflashing modes.
- SPRINT gate mode (high speed operation).

Lightning Protection

The A10 inverter and electronic controller utilizes the same proven surge protection philosophy that is used in all CENTSYS products. While this does not guarantee that the unit will not be damaged in the event of a lightning strike or power surge, it greatly reduces the likelihood of such damage occurring. The earth return for the surge protection is provided via the mains power supply earth. In order to ensure that the surge protection is effective, it is essential that the unit is properly earthed.

Theft Protection

While care has been taken in the design of the A10 to prevent unauthorized removal (theft) of the unit, an optional steel theft resistant cage is also available for added peace of mind.

Overall Dimensions

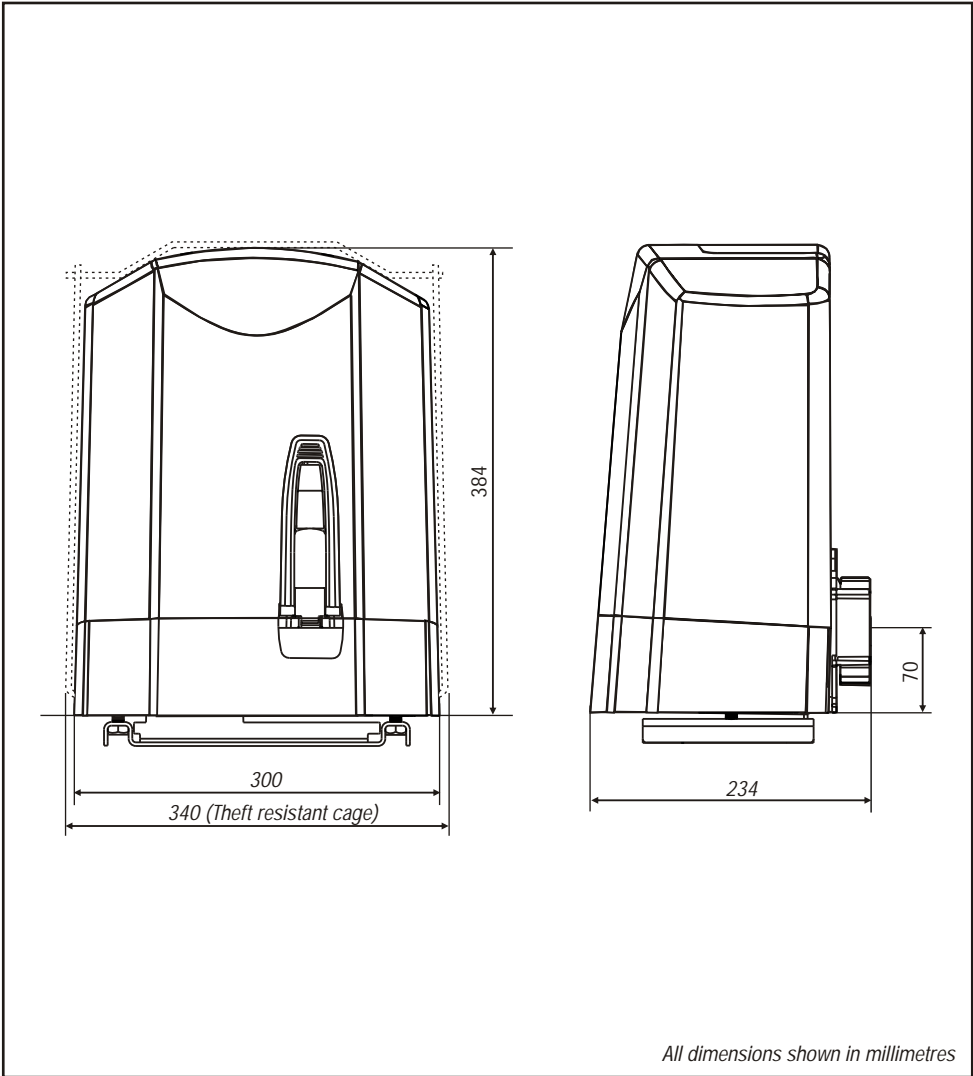

Figure 1 Overall Dimensions

Specifications

<i>SPECIFICATIONS</i>	<i>A10 BASIC</i>	
Power Supply	220-240V AC +/- 10%, 50Hz - 1 Phase	
Maximum Absorbed Current	6A	
Motor Voltage	220-240V AC 3 Phase	
Output Pinion	20 Tooth Mod 4	
Starting Thrust	(Standard speed) 40kgF	(Sprint speed) 30kgF
Rated Thrust	(Standard speed) 30kgF	(Sprint speed) 22.5kgF
Operating Speed @ Rated Thrust	16m/min	¹ Adj. Up to 30m/min
Motor Cooling	Direct Drive Fan (1400RPM)	
Duty Cycle (continuous) ²	45%	
Duty Cycle (30 minute endurance) ²	65%	
Ambient Temperature Range	-20°C to +50°C	
Anti-crushing sensing	Electronic	
Motor Thermal Protection	Electronic	
Maximum Gate length	20m	
IP Rating	44	
Optional Battery Back-up	Yes	
Shipping Mass of Unit	15.5kg	
Maximum Gate Mass	(Standard speed) 1000kg	(Sprint speed) 600kg

DC CONVERTER SPECIFICATIONS

Input Voltage	12V DC
Current Draw @ Rated Thrust	30A
Rated Output Voltage	310V DC
Battery Charger	³ 1A
Maximum Duty Cycle	20%
Thermal Protection	Electronic
Enclosure	IP65 External Plastic Enclosure
Dimensions	310mm X 240mm X 110mm
Battery Size	Std. 12V 7AH (External 40AH optional)
Open and Close Cycles ⁴	7 - 12 (7AH battery) 40 - 70 (40AH battery)
Shipping Mass	10kg (Inc 7AH Battery)

<i>A10 ENDURANCE</i>	<i>A10 HEAVY WEIGHT</i>
220-240V AC +/- 10%, 50Hz - 1 Phase	220-240V AC +/- 10%, 50Hz - 1 Phase
6A	6A
220-240V AC 3 Phase	220-240V AC 3 Phase
20 Tooth Mod 4	17 Tooth Mod 4
(Standard speed) 40kgF (Sprint speed) 30kgF	47kgF
(Standard speed) 30kgF (Sprint speed) 22.5kgF	35kgF
16m/min ¹ Adj. Up to 30m/min	13.6m/min
High Efficiency Fan (3000 RPM)	High Efficiency Fan (3000 RPM)
90%	90%
95%	95%
-20°C to +50°C	-20°C to +50°C
Electronic	Electronic
Electronic	Electronic
20m	17m
44	44
Yes	Yes
15.7kg	15.6kg
(Standard speed) 1000kg (Sprint speed) 600kg	2 000kg

(1) Refer to RATED THRUST values

(2) At rated thrust and 25°C maximum ambient temperature, unit in full shade.

(3) Upgradable on request.

(4) Dependent on site / environmental conditions.

Duty Cycle Curves

Calculating the duty cycle

The duty cycle is the ratio of the actual operating time to the total time (opening plus closing plus pause times). The formula for calculating it is the following:

$$\text{Duty cycle \%} = \frac{T_o + T_c}{T_o + T_c + T_p + T_i} \times 100$$

where: T_o = opening time;

T_c = closing time;

T_p = pause time;

T_i = interval between a complete cycle and the next

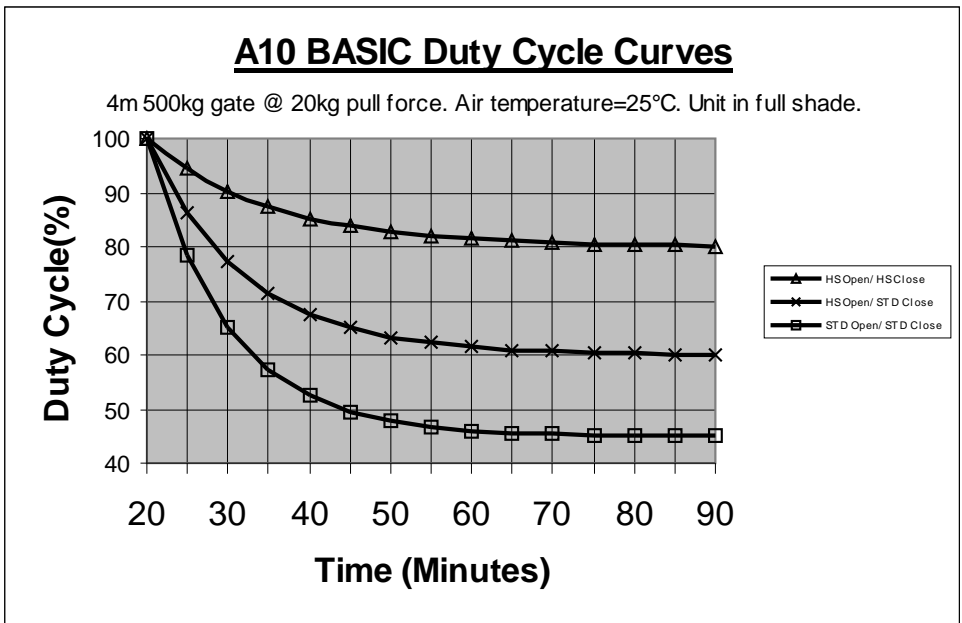

Figure 2 Duty Cycle Curves

A10 ENDURANCE Duty Cycle Curve All speed combinations

4m 500kg gate @ 20kg pull force. Air temperature=25°C. Unit in full shade.

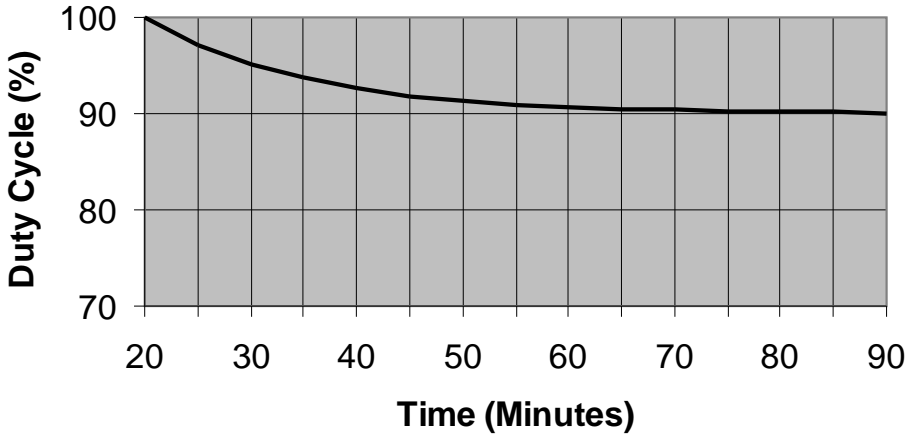

Figure 3 Duty Cycle Curves

Examples of how to read the duty cycle curves:

Referring to Figure 2, an A10 Basic, opening and closing at *standard (STD) speed* (■), can run at a duty cycle of 65% for 30 minutes, a duty cycle of 50% for 45 minutes, and a duty cycle of 45% for an unlimited time.

The same A10 Basic, opening at *high speed (HS)*, and closing at *standard (STD) speed* (✕), can run at a duty cycle of 78% for 30 minutes, a duty cycle of 65% for 45 minutes, and a duty cycle of 60% for an unlimited time.

The same A10 Basic, opening AND closing at *high speed (HS)* (▲), can run at a duty cycle of 90% for 30 minutes, a duty cycle of 83% for 45 minutes, and a duty cycle of 80% for an unlimited time.

Product Identification

The actual components supplied may vary depending on the model purchased.

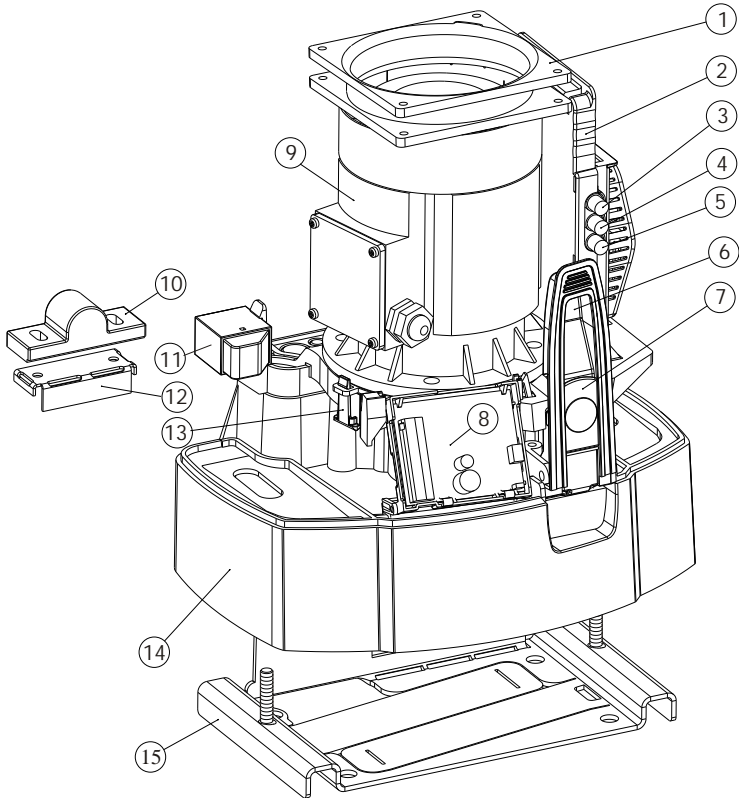

- | | | | |
|----|-------------------------------------|-----|----------------------------|
| 1. | High Efficiency Fan* | 9. | 3 Phase Motor |
| 2. | Inverter Module | 10. | Gate Mounted Origin Marker |
| 3. | Inverter Fuse (F1 5A F/B) | 11. | Origin Sensor |
| 4. | Logic Controller Fuse (F2 50mA S/B) | 12. | Origin Marker Bracket |
| 5. | Courtesy Light Fuse (F3 3A F/B) | 13. | Encoder Sensor |
| 6. | Manual Release Handle | 14. | Lower Cover |
| 7. | Lock Cover | 15. | Foundation Plate |
| 8. | Logic Controller | | *Not fitted to BASIC model |

Figure 4 Product Identification

Required Tools & Equipment

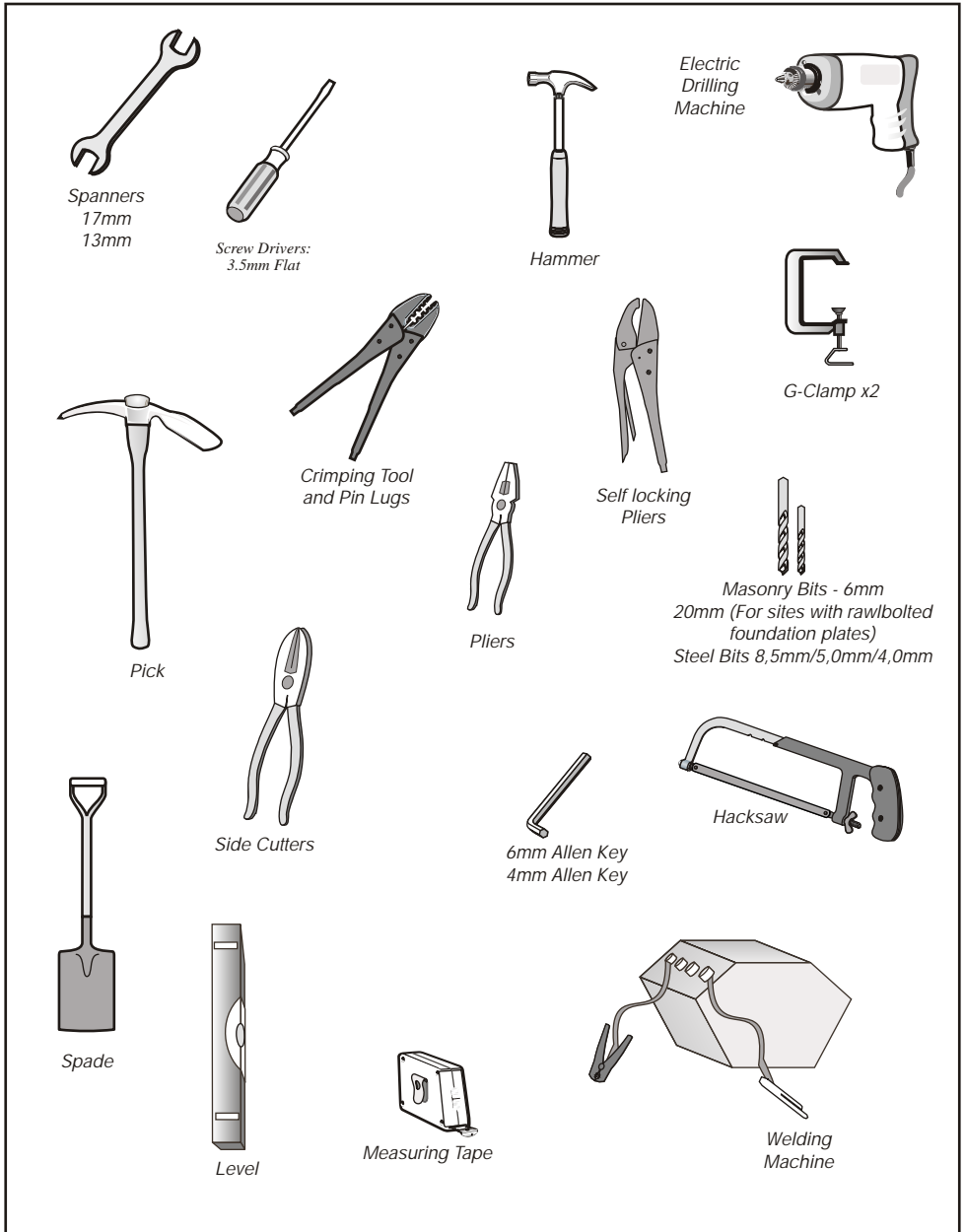

Figure 5 Required Tools and Equipment

Site Considerations

Install the gate operator only if:

1. It will not pose a hazard to the public.
2. There is sufficient clearance to a roadway and/or public thoroughfares.
3. The installation will meet all municipal and/or local authority requirements once completed.
4. The gate mass, length and application is within the operator specifications.
5. The gate is in good working order, meaning:
 - That it moves freely.
 - Does not move on its own if left in any position.
6. It can be installed to have sufficient clearance between moving parts when opening and closing to reduce the risk of personal injury and entrapment.
7. Pushbuttons or key switches, when required, can be positioned so that the gate is in line of sight of the operator.

General considerations for the installation:

1. Always recommend the fitment of additional safety equipment such as safety edges and safety beams, for additional protection against entrapment or other mechanical risks.
2. Check that no pipes or electrical cables are in the way of the intended installation.
3. Check that enough space is available for the gate operator with the gate in the required open position.
4. Check for loose sandy soil if installing foundations, as the soil condition may require a larger foundation.
5. Never fit the operator on the outside of the gate, where the public has access to it.

Endstops

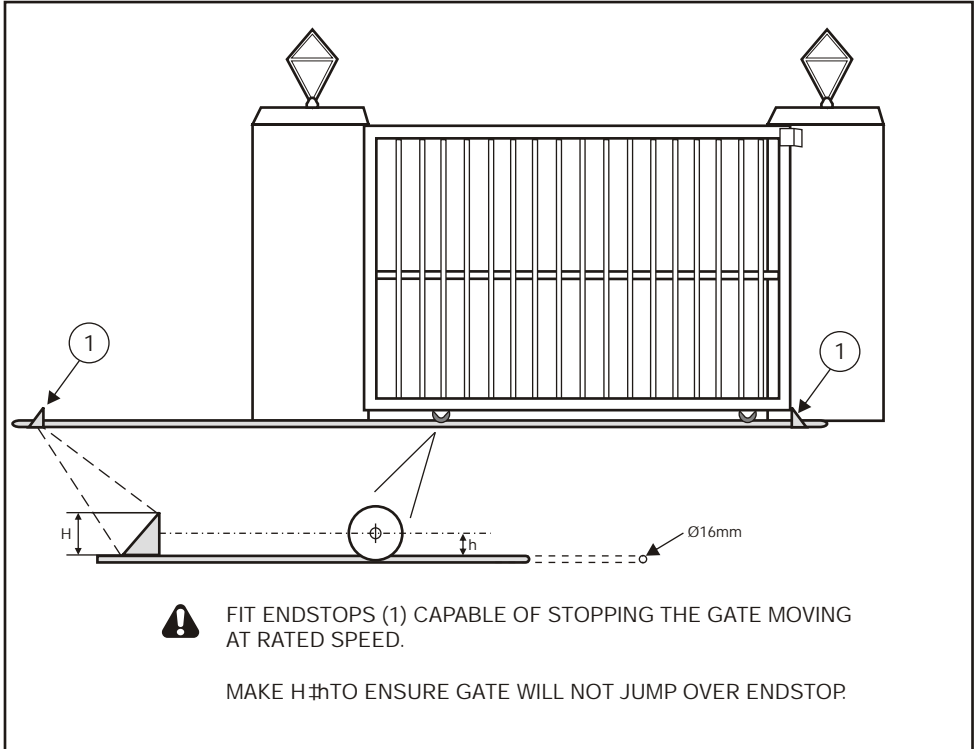

Figure 6 Gate Endstops

! WARNING

Due to the high speed at which the A10 operator can move a gate, it is extremely important to install endstops capable of stopping the gate moving at the rated speed. Refer to Specifications as detailed on Page 8 for the operating speed.

Anti-Lift Brackets

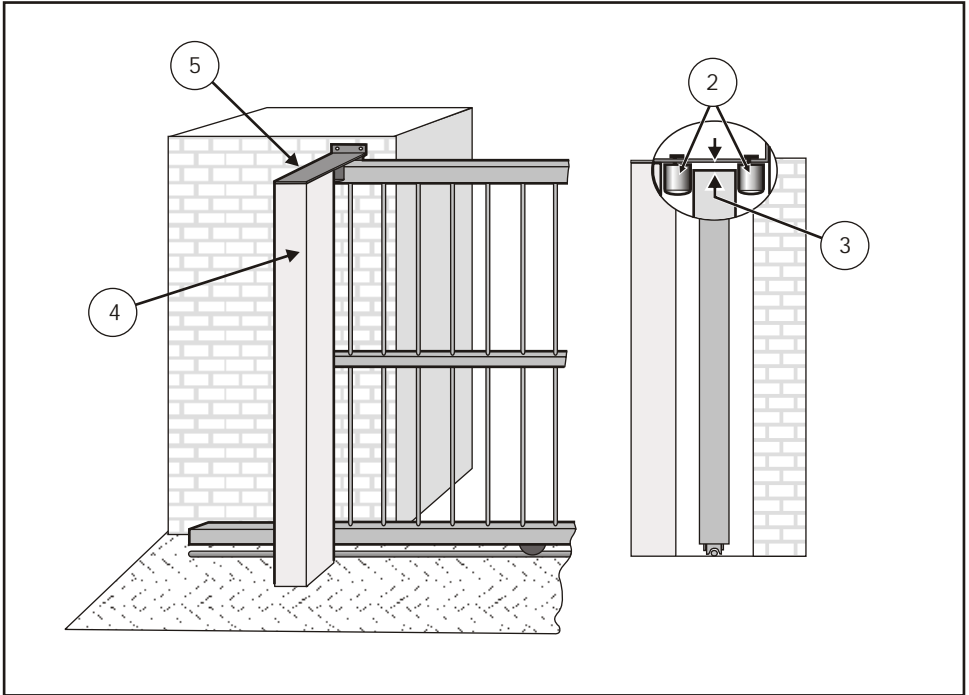

Figure 7 Anti-Lift Brackets

- Guide-rollers (2) must ensure that the gate is held vertically.
- Fit suitable anti-lift brackets (1). The gap (3) should be < 5mm to ensure the gate cannot be lifted off the motor pinion.
- For improved safety fit additional support post (4) to prevent gate from falling over if guide-rollers (2) fail.

Starting & Running Forces

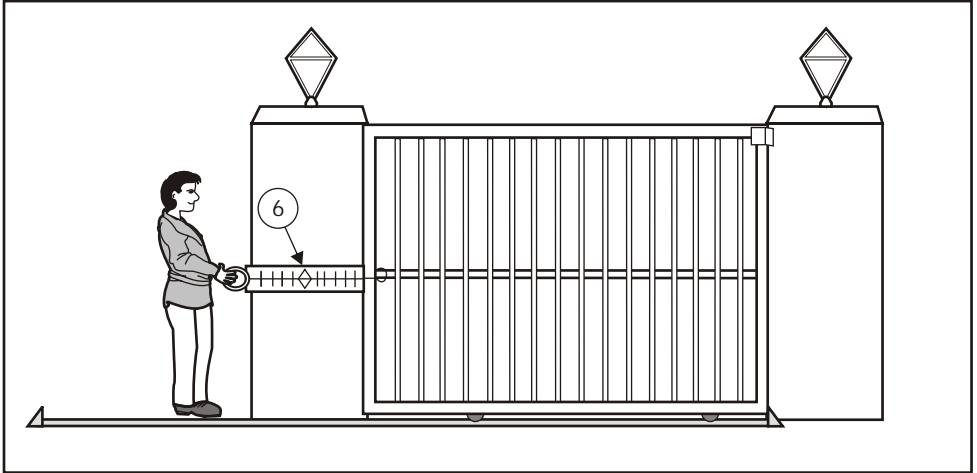

Figure 8 Starting and Running Forces

- The Centurion Systems (Pty) Ltd warranty will be void if the pull force (6), and/or gate mass, exceeds the operator specification (see table below)

Model \ Characteristic	Basic / Endurance	Heavy Weight
Starting Force	40kgF @ standard speed	47kgF
	30kgF @ sprint speed	
Running (rated) Force	30kgF @ standard speed	35kgF
	22.5kgF @ sprint speed	
Maximum gate mass	1000kg @ standard speed	2000kg
	600kg @ sprint speed	

Cabling Requirements

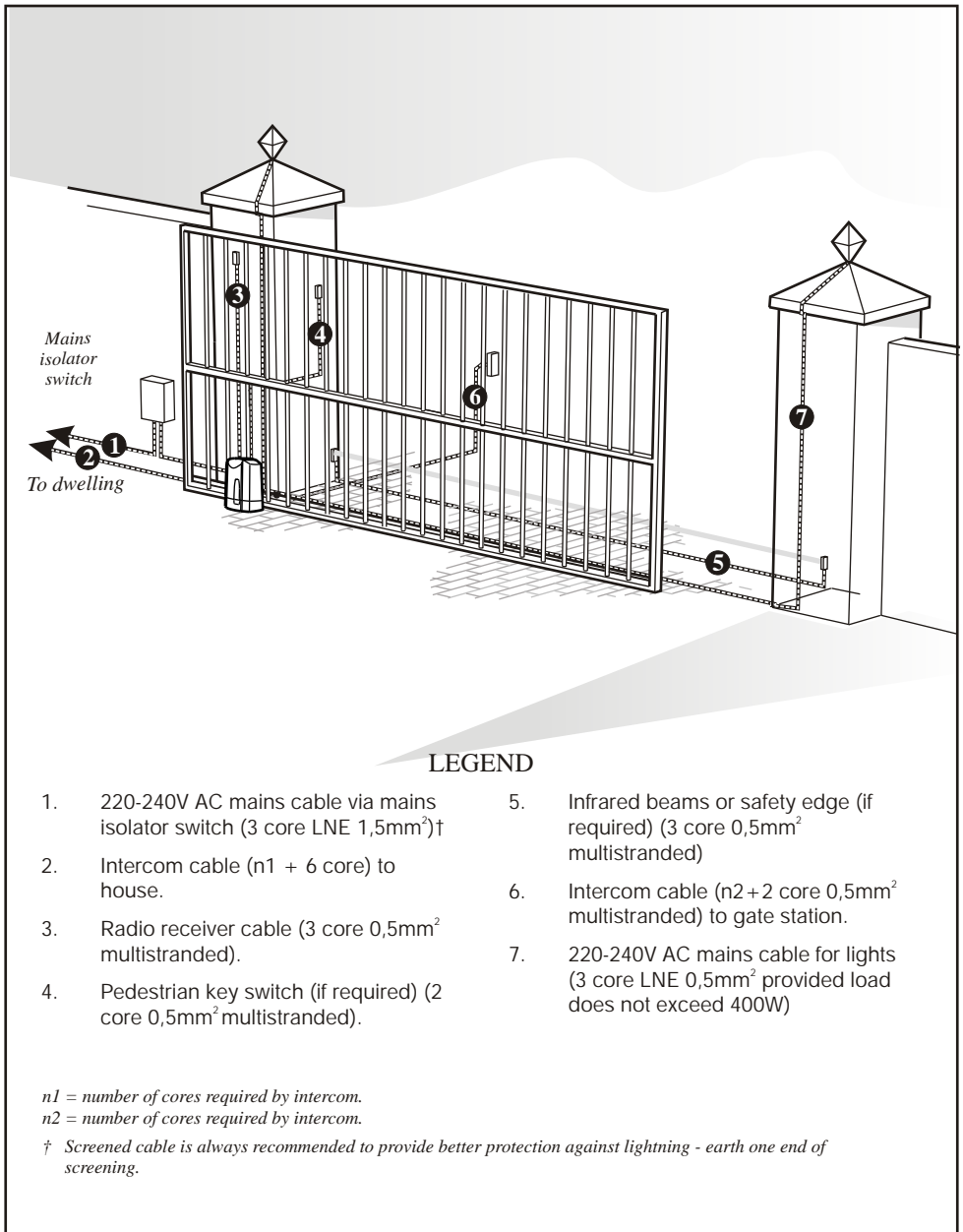

Figure 9 Cabling Requirements

Operator Installation

Foundation Plate Installation

Rack/Axle Clearance

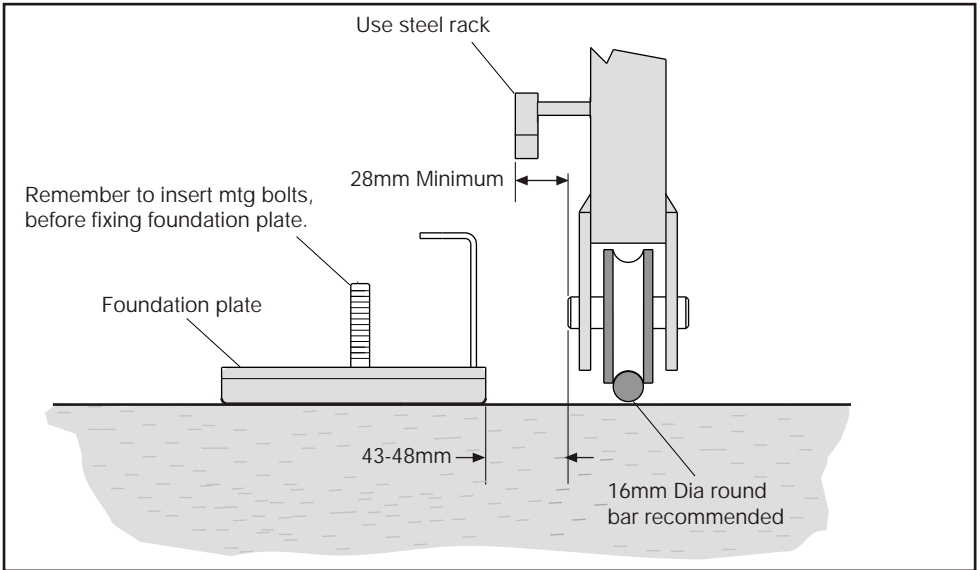

Figure 10 Rack Axle Clearance

Side Clearance

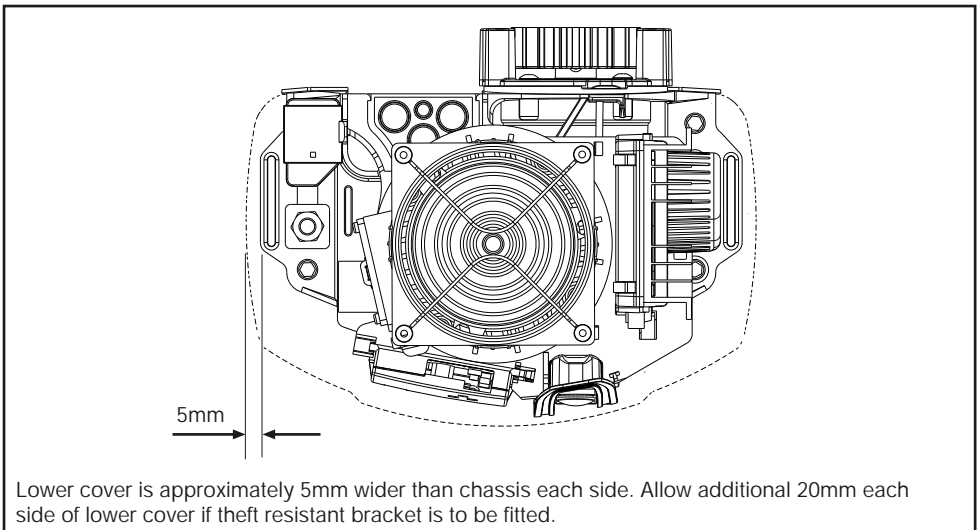

Figure 11 Side Clearance

Operator Installation

Foundation Plate Installation - option 1

(Bolted down to existing concrete block)

- The LH concrete anchor (7) may need to be broken off in order to clear incoming conduits.
- Make sure the M10 bolts (8) which secure the gearbox are in place.
- Refer to the Fig. 10 to ensure correct positioning. Mark through the foundation plate holes to indicate where to drill holes for the M10 rawlbolts (9).
- Use extra washers (10) as required to ensure the foundation plate is level.
- Drill the holes, grease the bolts, and bolt down the plate securely.

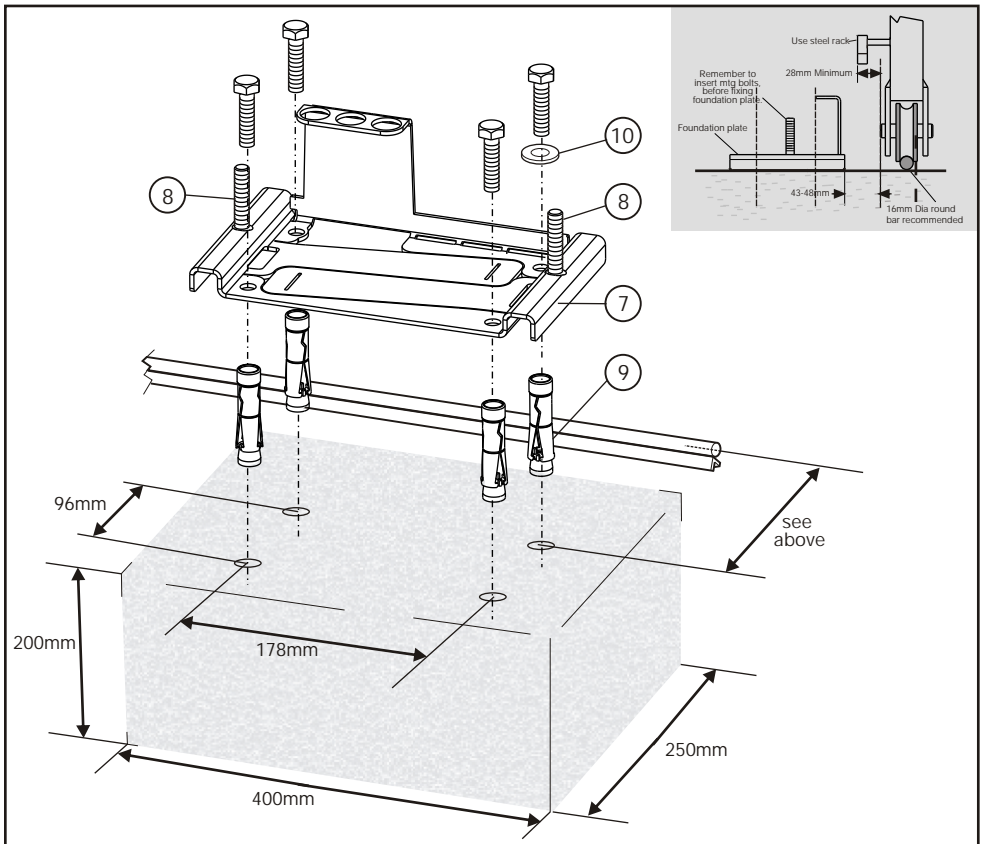

Figure 12 Foundation Plate Installation - Existing Concrete Block

Foundation Plate Installation - option 2

(Set in concrete)

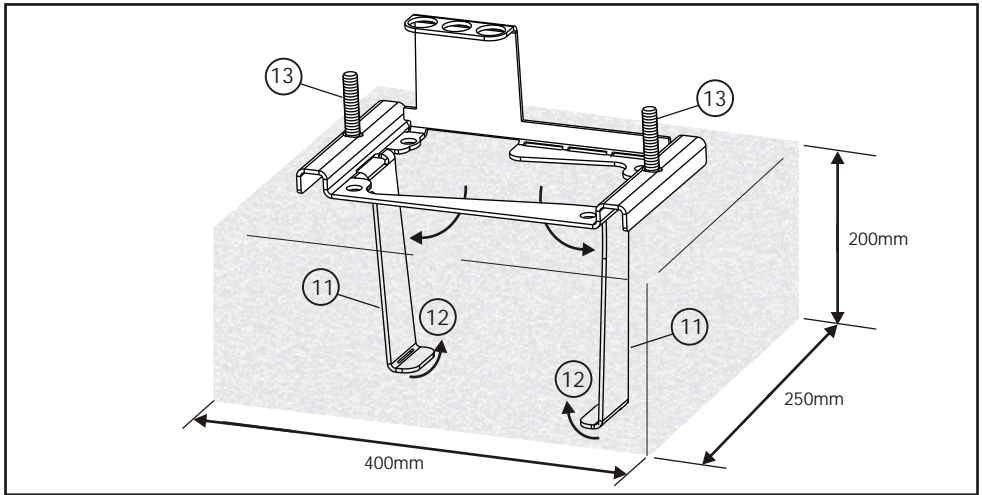

Figure 13 Foundation Plate Anchors

- The anchors (11) must first be bent down as shown in Figure 13.
- Use self locking or crimping pliers to bend the anchor tips (12) to the horizontal plane.
- Make sure the M10 bolts (13) which secure the gearbox are in place.
- Refer to Figure 14 to ensure correct positioning and set the foundation plate in concrete to the level indicated

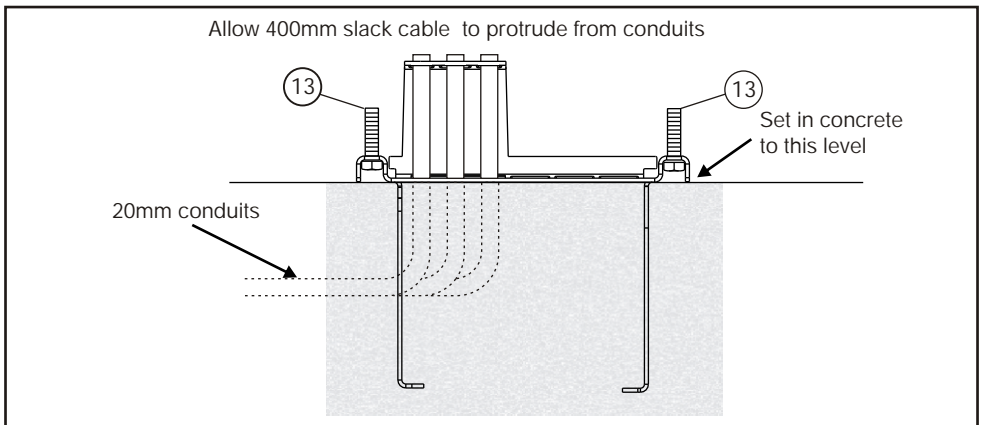

Figure 14 Set Foundation Plate in Concrete

Important Information

Lubrication

The internal wormshaft/wormwheel gearset of the A10 is lubricated by means of an oil bath.

⚠ ATTENTION

In order to prevent possible leakage during shipping, the unit is shipped with no oil inside the gearbox. A bottle containing 80 ml of EP 80W90 oil is included with the product, and this **MUST** be introduced **BEFORE** operating the product.

It is more convenient to insert the oil before bolting the unit down, as shown in Figure 15.

The A10 does not require routine oil changes. However in the event of the unit losing oil due to stripping down or mechanical damage, the correct replacement oil is EP 80W90 to API GL-5, i.e. Castrol EPX or equivalent.

If the gearbox is bolted down in the horizontal position during filling, the correct level is reached when oil begins to spill from the filler hole.

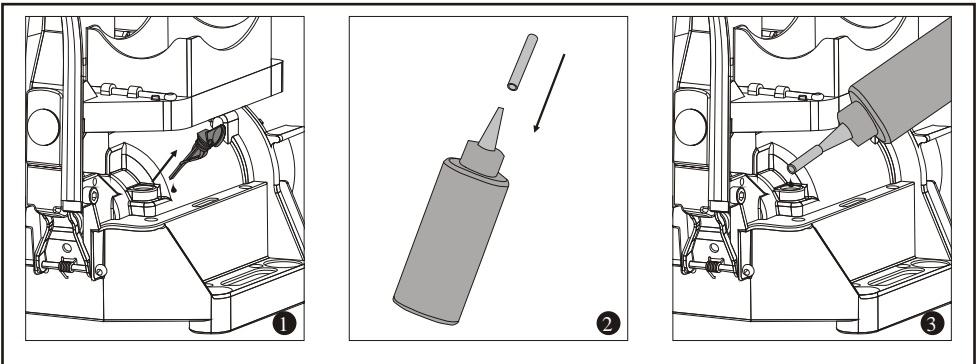

Figure 15 Filling The Gearbox With Lubricant

Step 1: Remove dipstick from gearbox

Step 2: Cut the tip off the nozzle which will allow for the oil to pass through the nozzle; unscrew the oil bottle cap; remove the seal from beneath the oil bottle cap; replace the oil bottle cap onto the bottle and, attach the extension tube to the nozzle

Step 3: Fill the gearbox with the oil provided

⚠ ATTENTION

PLEASE ensure that you **ONLY USE THE FOLLOWING OIL** as qualified by CENTSYS:

Castrol SAF-XO 75w-90 Synthetic Final Drive Lubricant.
CENTSYS re-order code OIL80ML0X0/H.

Operator Installation

Gearbox Mounting Down Details

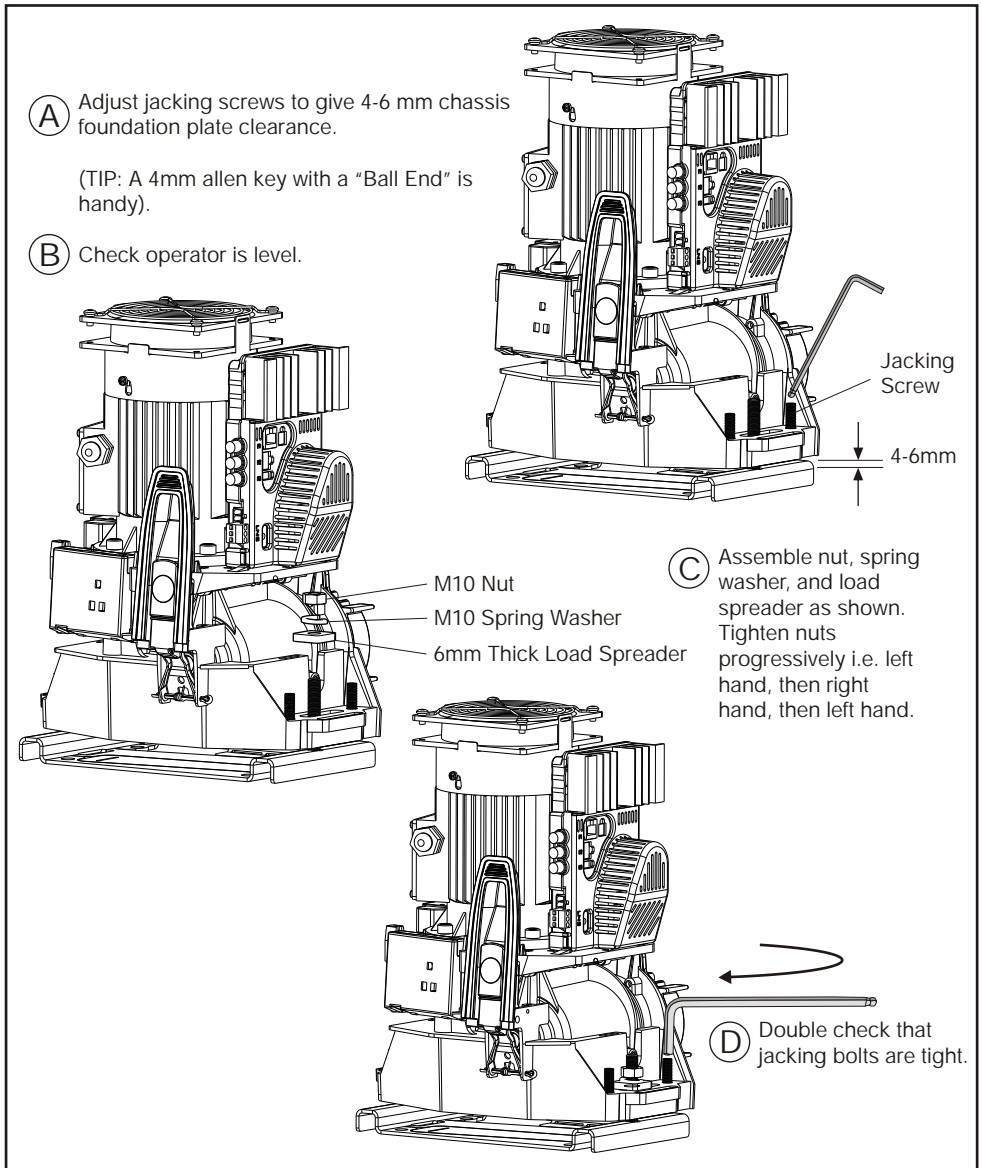

Figure 16 Gearbox Mounting Down Details

Joining/Mounting Rack

- A simple way of ensuring correct pitch spacing when joining steel rack is to clamp a small off cut (14) between the two pieces.
- Check that weld (15) does not foul with meshing surfaces.
- Attach steel rack to gate using 25x25x5mm angle brackets (16).
- For best results support rack every 300mm.
- Assuming the rail is level, the rack must also be mounted level with a 2 - 3mm clearance (17).

USEFUL TIP

- Raise gearbox by an additional 3mm.
- Put gearbox into manual mode (see page 41)
- Mesh rack and pinion fully and mount rack. Slide gate backwards and forwards ensuring that rack mesh is smooth and never tight.
- Drop gearbox by 3mm to create 3mm tooth clearance (Approximately 2.5 turns of the jacking screws).

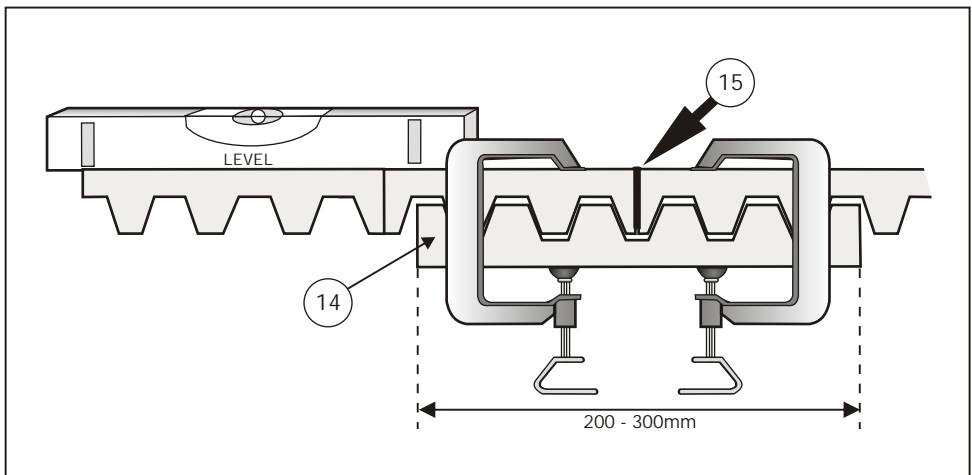

Figure 17 Joining Rack

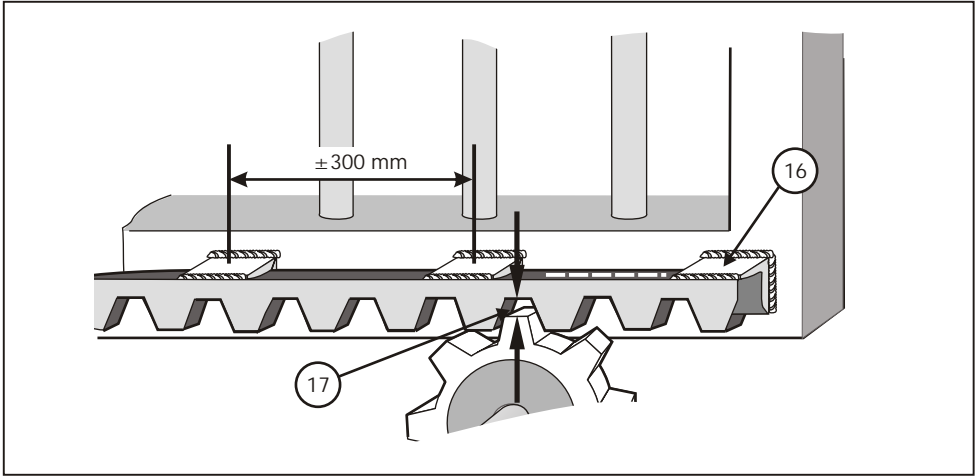

Figure 18 Mounting Rack

Chain Drive Installation (Optional)

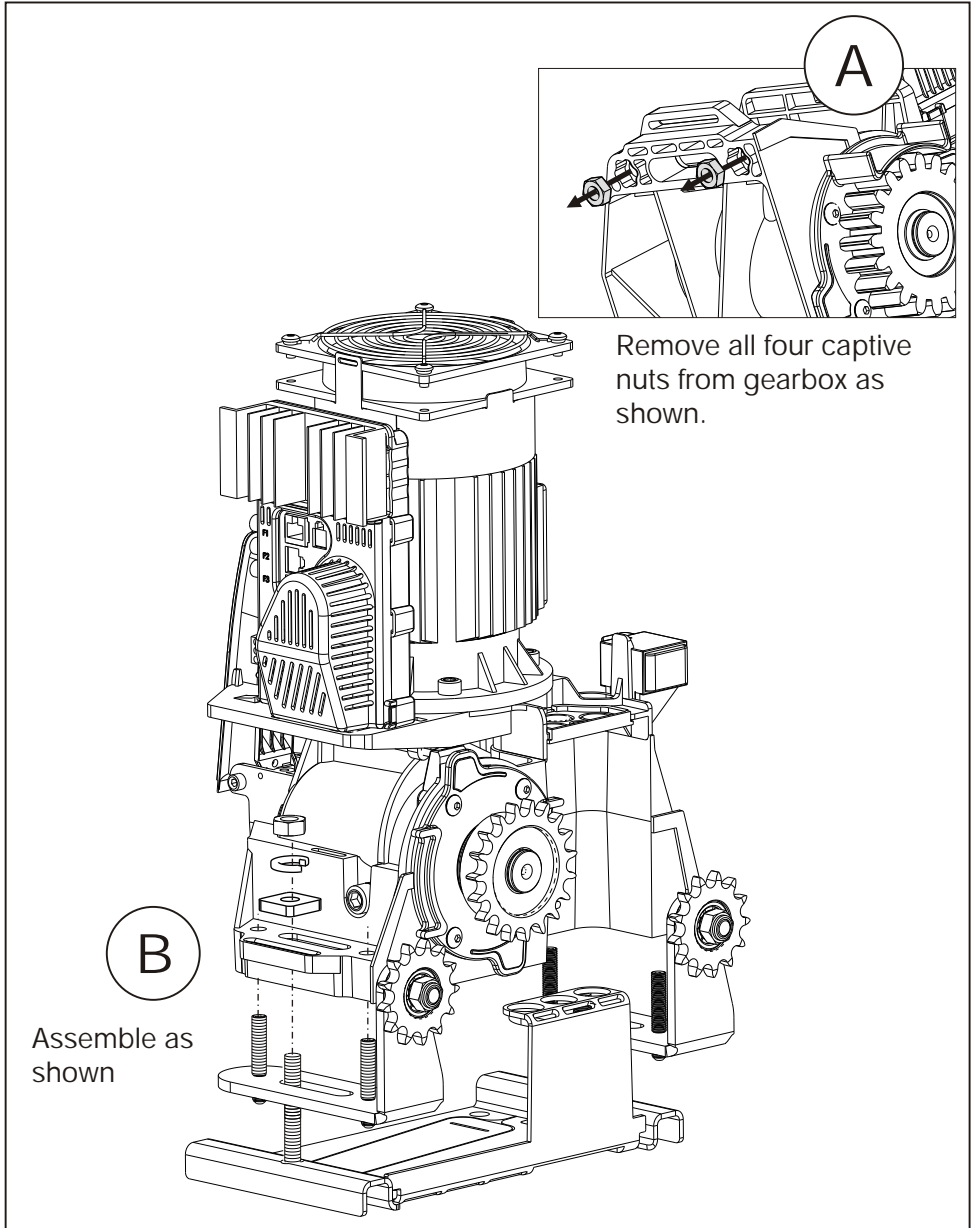

Figure 19 Chain Drive Installation

Installing Chain Drive Systems

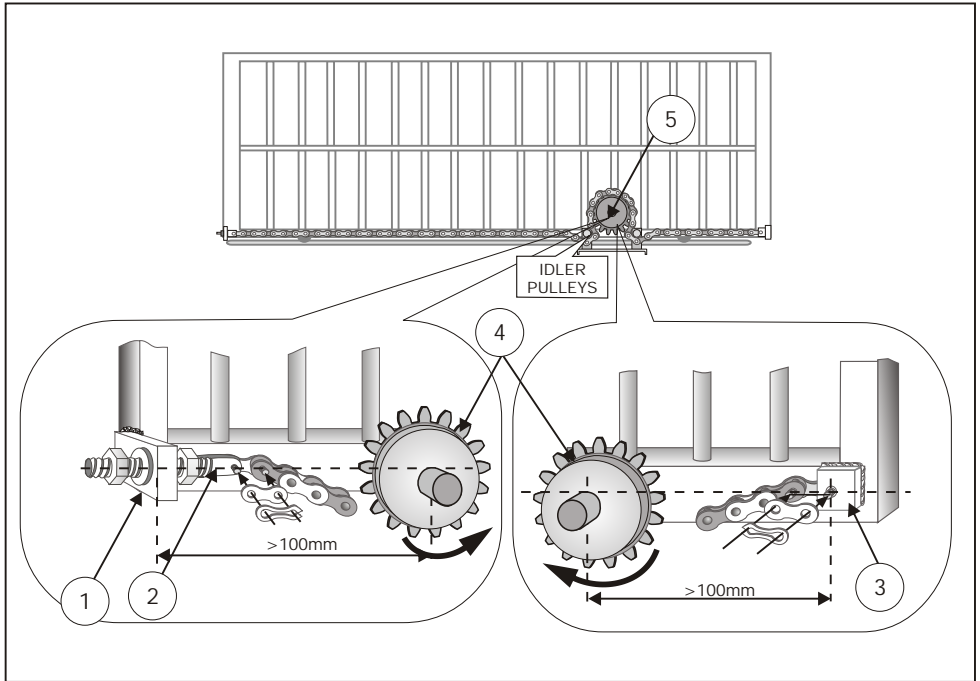

Figure 20 Chain Drive Installation

- Weld rear anchor plate (1) onto gate such that centre line of tensioner pin (2) is in line with top of the shaft on the idler pulley (4) . Allow at least 100mm between idler pulleys and anchor brackets.
- Align fixed anchor bracket (3) as for (1) .
- Ensure chain direction over sprocket is as shown (see (5)).

Origin Marker Mounting

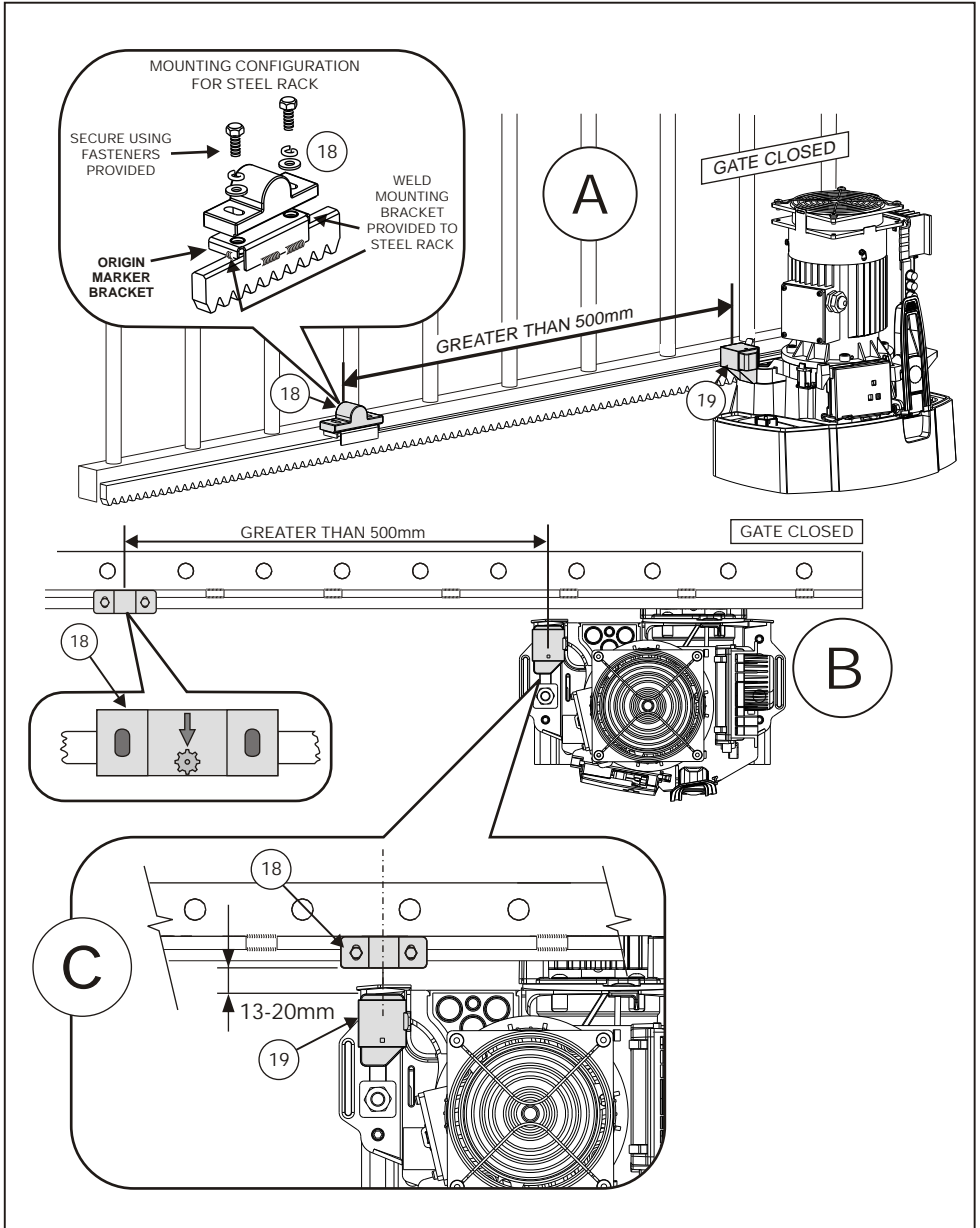

Figure 21 Origin Marker Mounting

-
- With the gate in the CLOSED position, mount the origin marker (18) a minimum of 500mm from the origin sensor (19). (See Fig. 21 isometric view A or plan view B)
 - Manually slide gate OPEN until origin marker (18) is in line with the origin sensor (19). Ensure distance between face of marker (18) and front face of sensor (19) is between 13 and 20mm. (See Fig. 21, view C)
 - Adjust distance by sliding the origin marker (18) along the slotted mounting holes until the specified distance is achieved.

Electrical Set-up

WARNING

1. Always check that the circuit breaker in the electrical panel is in the OFF position, and that all high voltage circuits (more than 42.4V) are completely isolated from the mains supply before doing any work.
2. Ensure that all low voltage systems (Less than 42.4V) are suitably protected from damage, by disconnecting all sources of power such as chargers and batteries before doing any work.
3. All electrical work must be carried out according to the requirements of all applicable local electrical codes. (It is recommended that a licensed electrical contractor perform such work.)

Connect all wiring

1. Ensure all interconnecting cables are securely in place (See diagrams on page 44 & 45).
2. Ensure single phase mains power is connected to the inverter (See diagram on page 45).

Programming the gate limits

3. Disengage the manual release lever, move the gate to the middle of travel, and re-engage the manual release lever.
4. Flip out the controller PCB as shown on page 31.

Get into programming mode

5. Fit the SET link jumper to the SET pins shown in Figure 23.
6. Press and release the RESET button. The STATUS light will flash five times. The SET and L2 lights will now be on. You are now in programming mode.

(See *Fault Finder's Guide* step 6) 

 NB: In case of the rack being underneath the pinion, first select inverted rack option (See Menu Item 16 on page 50)

7. Press and hold the TEST pushbutton (Figure 23) down, for one flash of L1, and then release. L2 will go off, and L1 will now be flashing once per second.
8. Determine right or left hand opening (as viewed from the release handle side of the motor). Again press and hold the TEST button, but this time monitor the STATUS light. Release the TEST button after ONE flash if gate opens to the right, or TWO Flashes if gate opens to the left.
9. The gate will begin to slowly open (If the gate starts to close, see *Fault Finders Guide*, page 39, step 9).

"Flip Out" Controller Mounting

Controller enclosure vertical

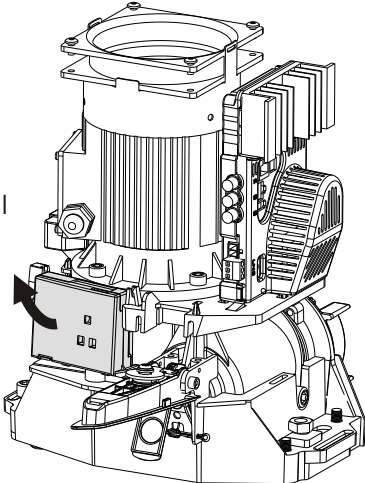

Controller enclosure raised

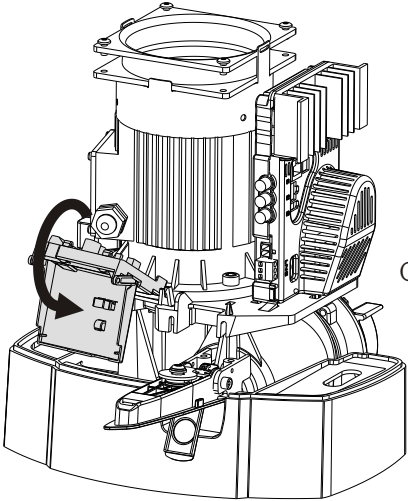

Controller enclosure propped

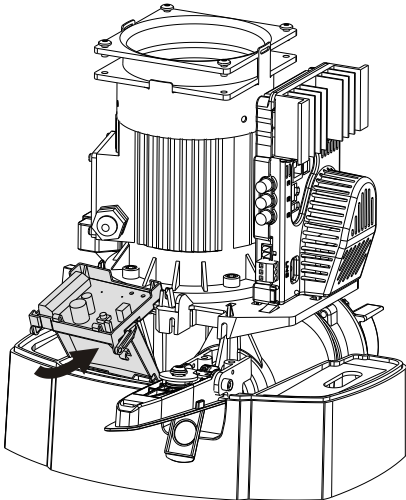

Figure 22 Controller Mounting

10. The gate will slowly open until it hits the open end stop, then slowly close until it hits the closed end stop.

11. The gate will then open at normal speed until the magnet passes the origin, and then slowly open until it hits the open end stop.

(See *Fault Finder's Guide* step 11) 

12. The gate will then close at normal speed until the magnet passes the origin and then continue to close slowly until it hits the closed end stop.

13. The gate will then open at normal speed until it reaches the minimum pedestrian opening position. If a wider pedestrian opening is required, jog the gate further open by shorting the PED input to COM.

When the correct position is reached, press the TEST button.

14. The STATUS light will flash five times, and L2 will light up. The gate limits have now been set.

15. If no additional Features are required, then exit programming mode by removing the SET link. Store the link by pushing it over ONE of the two pins.

16. Open and close the gate a few times to check operation.

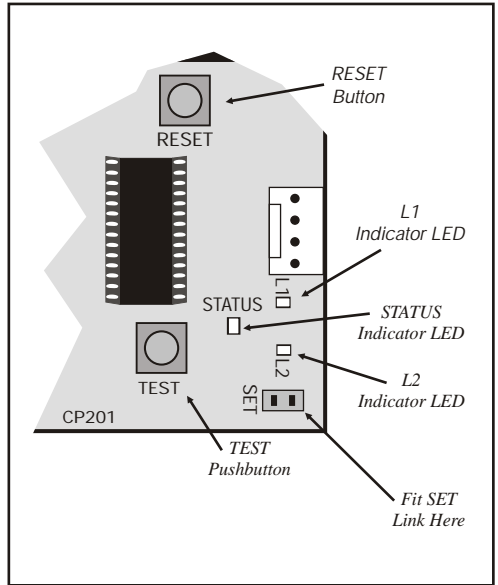

Figure 23 Controller SET Link & Programming LED's

Setting Additional Features (Optional)

The default factory settings on the CP201 Controller have been selected to suit most applications. In many cases there would be no need to change the default settings. A list of features can be found on page 47, with a detailed description of each feature on page 35.

Determine What Features are Required

17. Determine from Table 2 on page 47 what Features are required together with the STATUS or COUNT value.

Example: "To turn the AUTOCLOSE Feature ON": According to Table 2 the Autoclose feature is Feature number 2, and to turn it ON is a status of 1.

Get Into Programming Mode (Exactly the same as for limits setup)

18. Fit the SET link jumper to the SET pins as shown in Figure 23.
19. Press and release the RESET button. The STATUS light will flash 5 times. The SET and L2 lights will now be on. You are now in programming mode.

(See *Fault Finder's Guide* step 19) 

Selecting the Feature to Change

(This is the first of two steps in setting a Feature. This only SELECTS the feature to change).

20. To select the Feature to change, Press and hold the TEST button while monitoring L1.
21. L1 will flash once then go off, twice in short succession then go off, three times then go off, etc. Release the TEST button when the number of flashes is the same as the Feature number to select.

Example 1:

To select a MODE OF OPERATION (In this case select CONDOMINIUM, that is Feature number 4, to a status of 2 according to table 2 on page 49) Press and hold the TEST button while monitoring L1:

The L1 light will flash once and pause,
then flash twice and pause....
then flash 3 times and pause....
then flash 4 times and pause....

At this moment release the TEST button to select Feature 4. L2 will turn off, and L1 will keep on flashing 4 times and pausing to indicate that Feature 4 is selected



NOTE: The STATUS of the Feature is not changed yet, the feature has only been selected to be changed!

22. If an incorrect Feature is selected, press the reset button and restart from step 20. None of the Feature settings will have been altered at this stage.

Changing the STATUS or COUNT value of a Feature.

23. To set the STATUS value of the Autoclose, Mode of Operation, Collision Sensitivity, Positive Close Mode, Pre-flashing, Sprint Mode or Inverted Rack Features:

Press and hold the TEST button while monitoring the STATUS light. The STATUS light will flash the same as for selecting a Feature. (See Step 21) Release the TEST button when the number of flashes is the same as the STATUS value required.

Example 1 (continued):

To set the MODE OF OPERATION to CONDOMINIUM:

After selecting the Feature, again press and hold the TEST button while monitoring the STATUS light:

The STATUS light will flash once and pause,
then flash twice and pause.....

At this moment release the TEST button to give a STATUS value of 2. The Mode of Operation has been changed to Condominium.

 NOTE: Only after setting the STATUS, would the Mode of Operation be changed to Condominium!

L2 will come back on, indicating that the STATUS has been updated.

24. To set the COUNT value of the Autoclose timer, Pedestrian Autoclose timer, Courtesy light timer, Autoclose override timer, Pre-flashing time, Collision counter, or the motor cutout timer Features:

Press and hold the TEST button while monitoring the STATUS light. After a slight pause, the STATUS light will start flashing at an even rate. Count all the flashes, and release the TEST button when the number of flashes is the same as the COUNT value required.

Example 2:

Set the AUTOCLOSE TIME to 10 seconds (That is Feature number 3, to a COUNT value of 10):

First select the Feature number 3 as in steps 20 to 21. Then press and hold the TEST button while monitoring the STATUS light:

After a slight pause, the STATUS light will start flashing regularly:

Flash (1), Flash (2), Flash (3), Flash (4), Flash (5), Flash (6),
....Flash (9), Flash (10).

Example 2 (continued):

At this moment release the TEST button to give a COUNT value of 10.
This sets the Autoclose timer to 10 seconds.

L2 will come back on, indicating that the COUNT has been updated.

Controller Features

The terminology "FEATURE 2-2" refers to Feature number 2 with a status of 2. "FEATURE 3- COUNT" refers to Feature number 3, with a user specified COUNT value.

Autoclose (FEATURE 2 - STATUS)

This can be programmed ON (FEATURE 2-1) or OFF (FEATURE 2-2). The factory default is OFF. Autoclose has the function of automatically closing a gate after a preset Autoclose time. Autoclose is automatically enabled in Condominium or PIRAC mode.

A gate that is stopped while opening will always autoclose. A gate that is stopped while closing will remain where it stopped indefinitely.

The autoclose time is set in FEATURE 3-COUNT. It can be set from 1 to 255 seconds. It is possible for the user to temporarily turn off autoclose when the Mode of Operation is either STANDARD and REVERSING. This is done by applying an impulse to the TRG input at the time of opening the gate, for a period of time longer than the AUTOCLOSE OVERRIDE TIME as set in FEATURE 8-COUNT. To provide feedback that the override signal has operated, the gate will stop opening after the override time. The instant the impulse is removed the gate will complete its opening cycle. The Autoclose is now off and the gate will remain open indefinitely. The next impulse received on TRG will initiate the closing cycle and the autoclose is automatically re-instated.

Modes of Operation (FEATURE 4 - STATUS)

It is possible to select 5 different Modes of Operation: STANDARD, CONDOMINIUM, PIRAC, REVERSING AND PLC (FEATURE 4-1 to 4-5). Only one mode can be activated at any one time. All the modes are triggered by the contact present between the TRG input terminal and the COM terminal.

STANDARD MODE (FEATURE 4-1) (This is the factory default mode) - A trigger impulse will cause the gate to start moving (either open or closed depending on its position). A second impulse while the gate is still moving will stop the gate. A third impulse will cause the gate to reverse its direction of travel, i.e the action is START - STOP - REVERSE.

CONDOMINIUM MODE (FEATURE 4-2) - Any trigger will cause a gate which is closed or closing to open or re-open. If not already active the Autoclose will automatically be turned on when Condominium Mode is selected. It is only the Autoclose signal, which can close a gate in Condominium Mode. If a trigger impulse is given while the gate is open the Autoclose time is reset to its preset value.

PIRAC MODE (FEATURE 4-3) - An acronym for Passive Infra Red Autoclose, this mode operates similarly to Condominium mode but instead of waiting for the autoclose timer to close the gate, it will close as soon as an object that has passed through the gate clears the infrared beam. If the beam is not broken the gate will get to its fully open position and close after the preset Autoclose time. This feature will only operate if infrared safety beams or if an inductive loop is fitted (IRB terminal).

REVERSING MODE (FEATURE 4-4)- This mode is similar to standard mode but instead of stopping a gate when it is in motion, a trigger will cause the gate to reverse its direction of travel. It is thus impossible to leave a gate stationary in a partly open position. The only two normally stable states are fully open or fully closed. If the Autoclose is ON then the gate will always tend towards being closed.

PLC MODE (FEATURE 4-5) - This mode provides separate open, close and stop inputs, and is suitable for sites where a PLC (Programmable Logic Controller) or PC is used to control access. Momentarily connecting FRX to COM will open the gate, momentarily connecting PED to COM will close the gate, and momentarily disconnecting LCK from COM will stop the gate.

Pedestrian Autoclose Time (FEATURE 5-COUNT)

A separate Autoclose timer exists for the pedestrian opening. The time can be set from 1 to 255 seconds but cannot be turned off completely. The default time is 5 seconds.

Courtesy (Pillar) Light (FEATURE 6-COUNT)

The pillar light circuit has multiple functions:

- It operates as a courtesy light and switches on for a timed period (The factory default is 2 minutes) (set by FEATURE 6-COUNT) every time the gate triggers.
- It can be turned on for the preset timed period, by the application of a short impulse between the SET terminal and COM.
- It can be turned ON permanently by application of an impulse longer than 3 seconds on SET and COM terminals. A short impulse thereafter will switch

the lights off. The gate will not trigger open when using the SET trigger. The fact that the pillar light is ON permanently is indicated by the STATUS LED flashing once every 2 seconds.

- When the PED input is triggered the pillar light flashes for an adjustable (1 to 255 seconds) pre-flash time (FEATURE 11-COUNT) before the pedestrian gate opens. (Default pre-flash time is 2 seconds).
- The contact can be used to operate a lamp, which will warn that the gate is about to open. Selection of pre-flashing is done in FEATURE 10. Three modes and OFF are selectable (The factory default is OFF):
 - Mode 1 - Light comes on only while gates are in motion.
 - Mode 2 - Light flashes at 1Hz for the pre-flash time and then flashes in synchronism with the STATUS LED while the gates are in motion.
 - Mode 3 - Light comes on for the pre-flash time and while the gates are in motion.

Collision Sensitivity (FEATURE 7-1 to 7-3) (THE FACTORY DEFAULT IS 7-1)

If the gate is obstructed the internal collision circuitry will activate. When the gate is opening, and it is obstructed the gate will stop. During closing however, an obstruction will cause the gate to immediately stop and reverse direction. There is a counter (FEATURE 12-COUNT) that monitors the number of collisions. If the collision count is reached before the gate reaches the fully closed position all trigger signals are inhibited for a 1-minute period. The STATUS LED flashing four times indicates this condition. After the one-minute period, triggers will again become active, (with the exception of Autoclose). The fault indication will continue to flash indefinitely after the 1-minute period but will clear after the 1-minute period if a valid trigger is given. The collision counter resets to zero after the 1 minute delay, or if the processor is reset (e.g. By removing all power from the controller).

Positive Close Mode (FEATURE 9-STATUS)

Setting Positive Close Mode to ON (FEATURE 9-1) (default is OFF, FEATURE 9-2) will allow the gate to drive up against the closed end stop without causing the collision circuitry to operate. This Feature operates only during the ramping down period in the closing direction.

Sprint Mode (FEATURE 13-STATUS, FEATURE 14-STATUS)

It is possible to select four different gate speeds. Feature 13 selects the opening speed, while feature 14 selects the closing speed.

FEATURE13-1 Gate will open at standard speed.

FEATURE13-2 Gate will open at standard speed + 30%.

FEATURE13-3 Gate will open at standard speed + 60%.

FEATURE13-4 Gate will open at standard speed + 90%.

FEATURE14- 1 Gate will close at standard speed.

FEATURE 14-2 Gate will close at standard speed + 30%.

FEATURE 14-3 Gate will close at standard speed + 60%.

FEATURE 14-4 Gate will close at standard speed + 90%.

CUTOUT TIMER: (FEATURE 15-COUNT)

The cutout timer will automatically shut off the motor after a predetermined time. This is useful in the case where a mechanical failure prevents the gate from reaching its end limit. The default cutout time is 60 seconds.

INVERTED RACK: (FEATURE 16-STATUS)

In the case where the rack is mounted UNDERNEATH the pinion (i.e.: upside down), it is necessary to select the inverted rack option (FEATURE 16-1). This will ensure that the gate directions are correctly calculated. The default status is OFF (FEATURE 16-2)

Procedure to Programme Controller Back to Factory Default Settings

1. Apply power.
2. Fit the "SET" link.
3. Connect "PED" and "FRX" to "COM".
4. Briefly depress the RESET button. STATUS light will flash five times, and then L1 and L2 will illuminate.
5. Remove the "SET" link and disconnect "PED" and "FRX" from "COM".
6. Briefly depress the RESET button. STATUS light will flash five times.
7. The card is now programmed to default settings as shown in Table 2 (see page 47) (Gate end points are not affected).

Fault Finder's Guide

All the known causes of problems are listed, according to the step number in the gate limits setup instructions.

<i>STEP</i>	<i>PROBLEM</i>	<i>POSSIBLE CAUSES & SOLUTIONS OF PROBLEM.</i>
6. or 19	<p>SET light is not on:</p> <p>L2 is not on:</p> <p>STATUS light did not flash five times:</p>	<p>Check that the SET jumper is correctly fitted. Fit and remove the SET jumper a few times to ensure good contact.</p> <p>Momentarily press the RESET button. The STATUS light will flash 5 times, then L2 will illuminate.</p> <p>Momentarily press the RESET button.</p>
9	Gate starts to close when it should be opening.	<p>Has gate direction been correctly determined? See step 8 in the electrical setup.</p> <p>Has inverted rack option been selected (Menu item 16-1)? If in doubt, reset controller to factory defaults (see above)</p>
11	Gate hits closed end stop, but does not re-open	<p>Is the magnetic sensor switch functioning correctly? Ensure the gate magnet passes as close as possible to the sensor. (see Fig 21 C) Page 28</p> <p>Has inverted rack option been selected (Menu item 16)? If in doubt, reset controller to factory defaults (see above)</p>

Receiver Installation

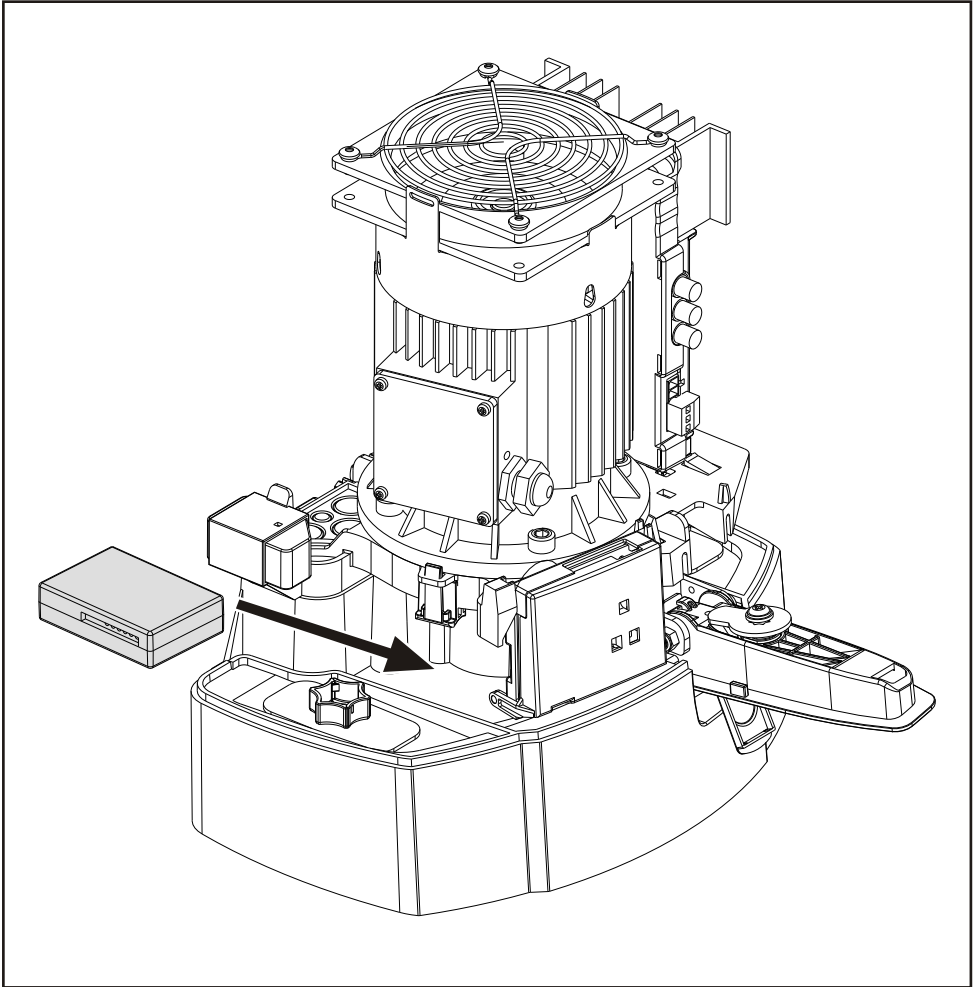
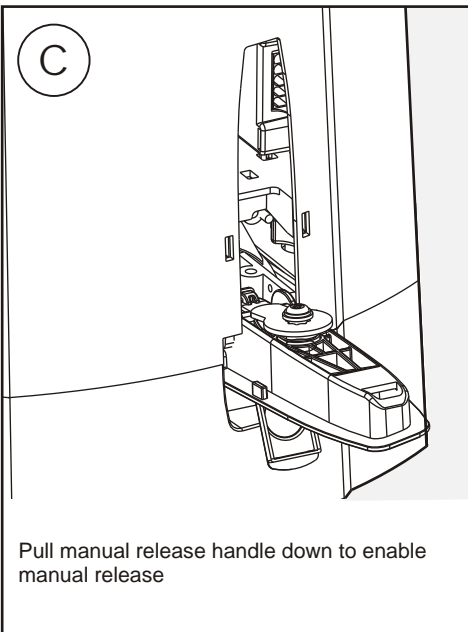
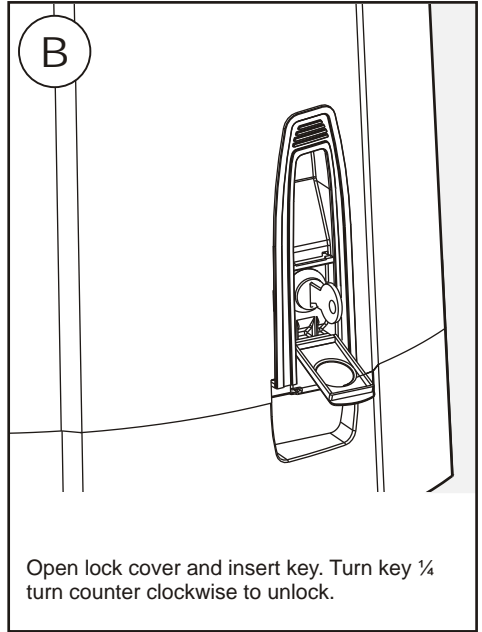
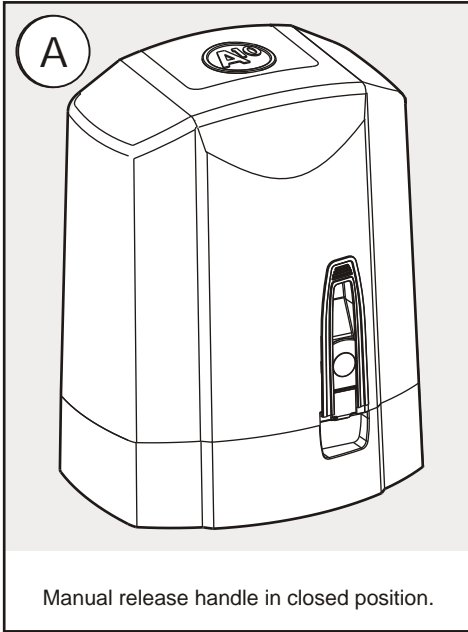

Figure 24 Receiver Installation



NOTE: Although a space is provided for locating a radio receiver within the unit, best results will be achieved by mounting the receiver externally as high as possible.

Manual Release Operation



Manual Release Latching

In the event of power failure, or product malfunction, it may be required to lock the cover in place whilst "latching" the manual release (i.e. manual release permanently enabled). This helps prevent theft of the unit, or its components, and provides full protection from the elements.

Manual release latching is effected using a split pin as shown below.

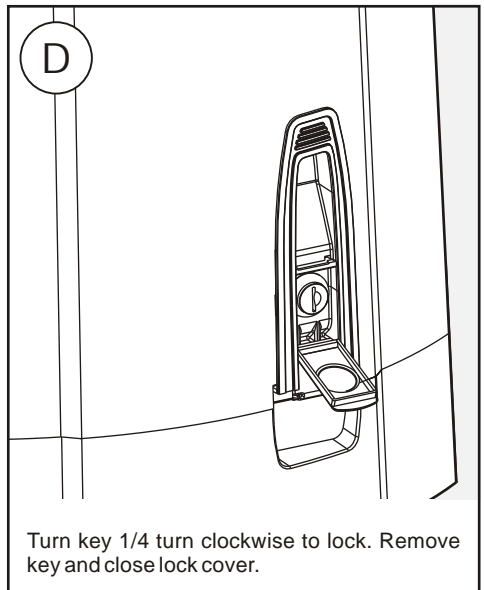
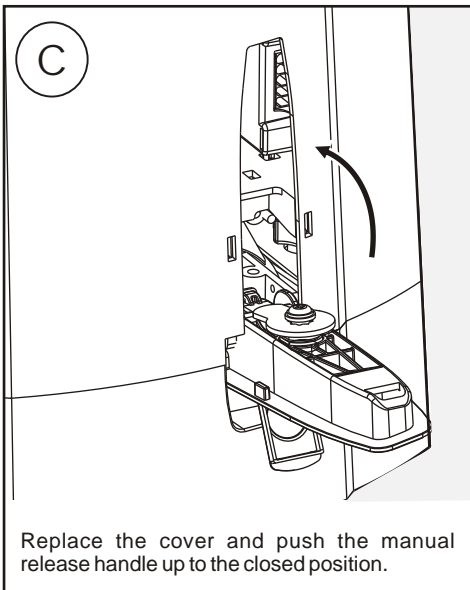
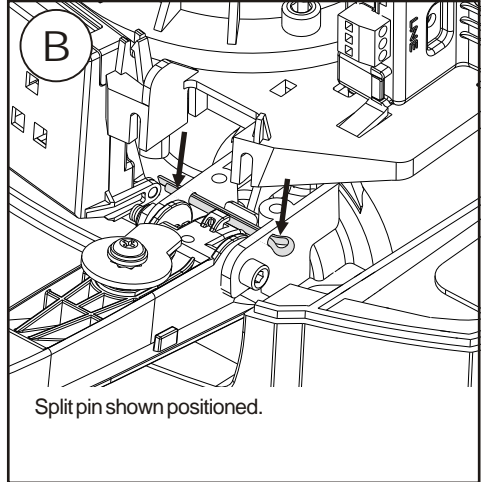
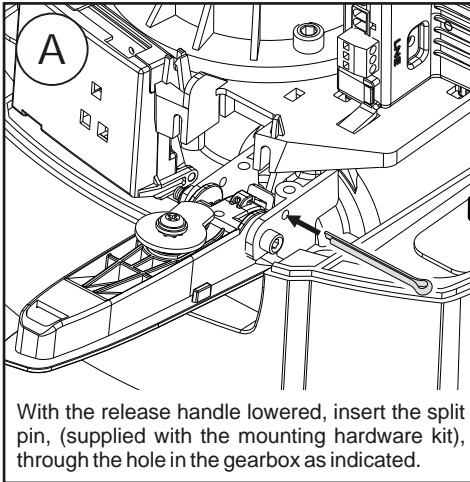

CP201 Trigger Connections

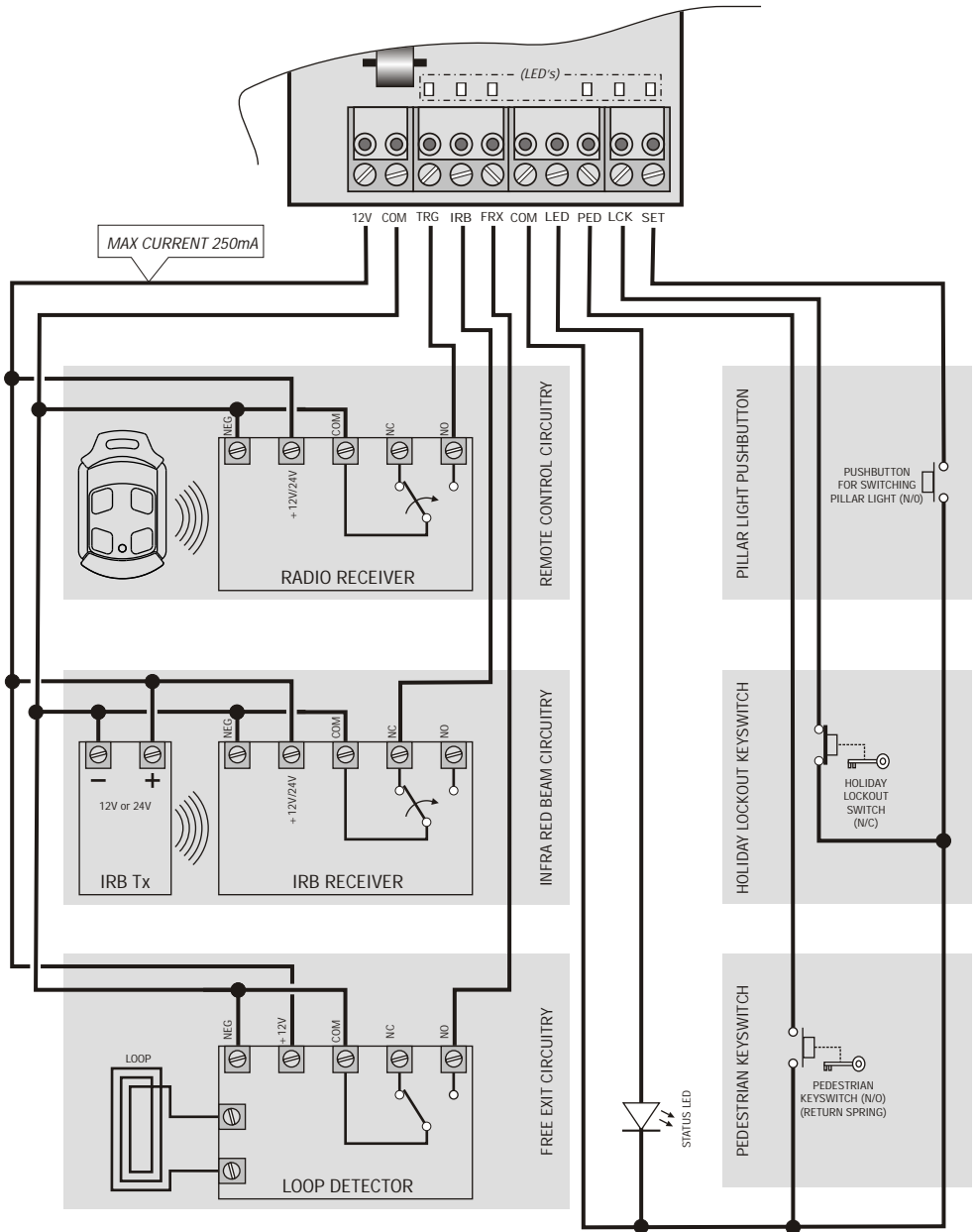

Figure 25 CP201 Trigger Connections

A10 Cable Routing

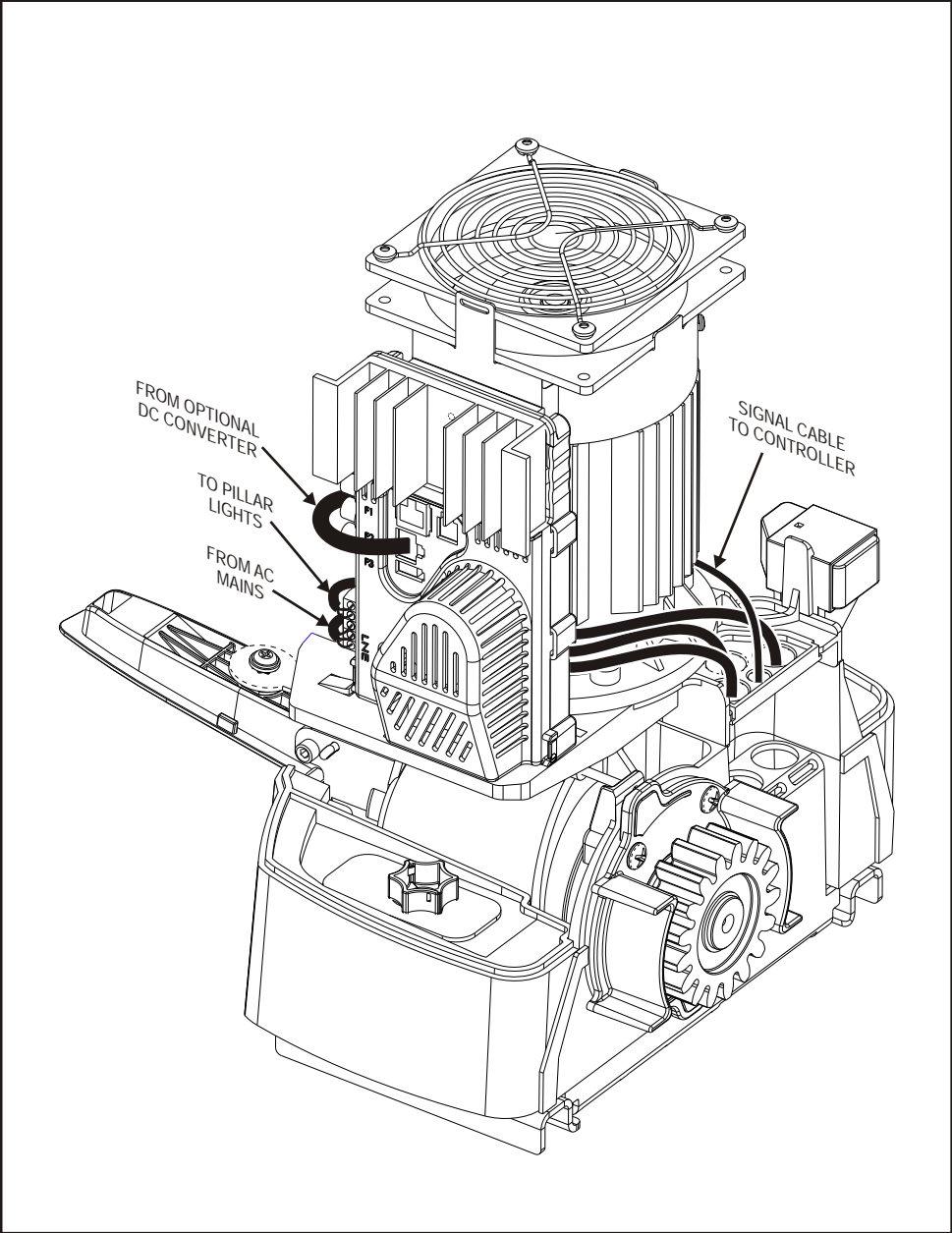

Figure 26 A10 Cable Routing

A10 Cable Interconnections

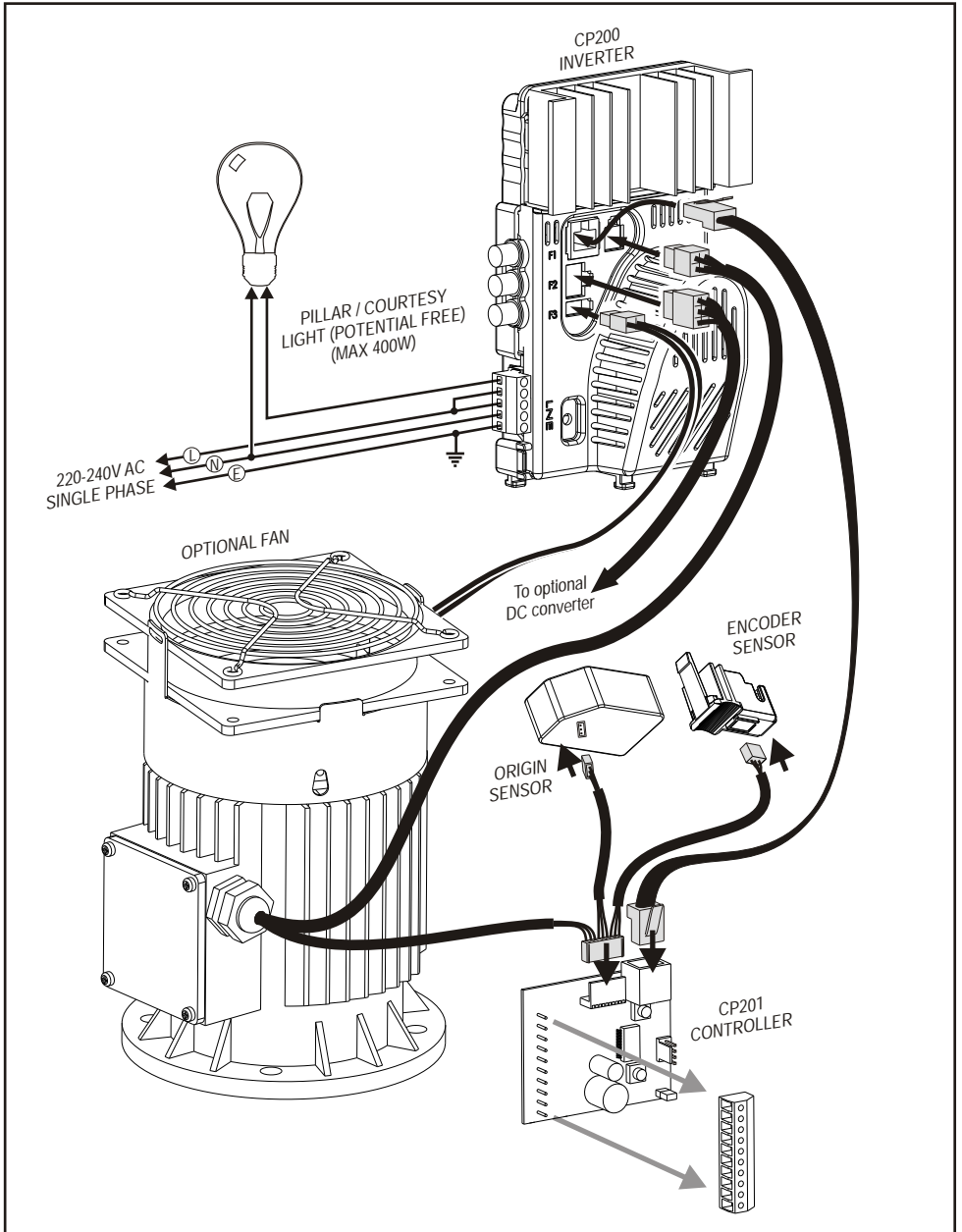

Figure 27 A10 Cable Interconnections

LED Indicator Lights

The controller is fitted with diagnostic LED's (Light Emitting Diodes) that assist with the set-up and maintenance of the gate. Table 1 provides a description and purpose of the indicator LED's. See Figure 23 and 25 for location.

NAME	COLOUR	ON	OFF	REMARKS
TRG	Red	Signal present	No signal	N/A
IRB	Green	Safeties clear	Safeties obstructed	N/A
FRX	Red	Signal present	No signal	N/A
PED	Red	Signal present	No signal	N/A
LCK	Green	System ready to operate	System locked	N/A
SET	Red	Signal present	No signal	N/A
STATUS (During normal operation)	Red	Gate fully open	Gate fully closed	1 Flash/sec - Pillar light on permanently 2 Flashes/sec - Thermal shutdown 3 Flashes/sec - Origin failure 4 Flashes/sec - Collision detector operated 5 Flashes/sec - Microprocessor reset
STATUS (During programme mode)	Red			The number of flashes correspond to the STATUS or COUNT value being set.
L1 (During normal operation)	Red			Origin diagnostic (Changes state to indicate origin status) Off when gate is on "CLOSED" side. On when gate is on "OPEN" side.
L1 (During programme mode)	Red	If LED2 also on, system reset to factory default.		The number of flashes corresponds with the FEATURE number being selected
L2 (During normal operation)	Red			DOSS diagnostic (Changes state to indicate DOSS pulses)
L2 (During programme mode)	Red	System in programme mode. If L1 also on, system reset to factory default.		

Table 1 LED Indicator Light Description & Purpose

Controller Functions

FEATURE		STATUS or COUNT		
DESCRIPTION	FEATURE NUMBER	STATUS VALUE	COUNT VALUE	DESCRIPTION
Gate Limit Settings	1	-	-	See detailed instructions on page 30
Autoclose	2	1	-	ON
		2	-	OFF (Default)
Autoclose Time	3	-	1 Flash = 1 second	15 seconds (Default)
Mode of Operation	4	1	-	STANDARD (Default)
		2	-	CONDOMINIUM
		3	-	PIRAC
		4	-	REVERSING
		5	-	PLC
Pedestrian Auto-close	5	-	1 Flash = 1 second	5 seconds (Default)
Courtesy Light	6	-	1 Flash = 10 seconds	120 seconds (Default)
Collision Sensitivity	7	1	-	HIGH (Default)
		2	-	MEDIUM
		3	-	LOW
Autoclose Override	8	-	1 Flash = 1 second	3 seconds (Default)
Positive Close Mode	9	1	-	ON
		2	-	OFF (Default)
Preflashing	10	1	-	MODE 1
		2	-	MODE 2
		3	-	MODE 3
		4	-	OFF (Default)
Preflash Time	11	-	1 Flash = 1 second	2 seconds (Default)
Collision Counter	12	-	1 Flash = 1 count	4 collisions (Default)
Opening sprint mode select	13	1	-	Standard speed (Default)
		2	-	Standard speed + 30%
		3	-	Standard speed + 60%
		4	-	Standard speed + 90%

Table 2 Controller Functions Menus and Submenus

FEATURE		STATUS or COUNT		
DESCRIPTION	FEATURE NUMBER	STATUS VALUE	COUNT VALUE	DESCRIPTION
Closing sprint mode select	14	1	-	Standard speed (Default)
		2	-	Standard speed + 30%
		3	-	Standard speed + 60%
		4	-	Standard speed + 90%
Motor cutout time	15	-	1 Flash = 1 second	60 seconds (Default)
Inverted Rack	16	1	-	Rack below pinion
		2	-	Rack above pinion (Default)

Table 2 continued Controller Functions Menus and Submenus

Installation Handover

Once the installation has been successfully completed and tested, it is important for the installer to explain the operation and safety requirements of the system.

NEVER ASSUME THE USER KNOWS HOW TO SAFELY OPERATE AN AUTOMATED GATE. Even if the user has used one before, it does not mean he knows how to SAFELY operate it. Make sure that the user fully understands the following safety requirements before finally handing over the site.

Ensure that the user fully understands:

- How to operate the manual release mechanism. (By demonstration).
- How the obstruction detection and all other safety features work. (By demonstration).
- All the safety considerations associated with operating an automated gate, and that he understands that he is responsible for explaining these safety instructions to all other users of the automated system:
 1. Do not activate your gate opener unless you can see it and can determine that its area of travel is clear of people pets, or other obstructions.
 2. **NO ONE MAY CROSS THE PATH OF A MOVING GATE.** Always keep people and objects away from the gate and its area of travel.
 3. **NEVER LET CHILDREN OPERATE OR PLAY WITH THE GATE CONTROLS,** and do not allow children or pets near the gate area.
 4. Be careful with moving parts and avoid close proximity to areas where fingers or hands could be pinched.

-
5. Secure all easily accessed gate opener controls in order to prevent unauthorized use of the gate.
 6. Keep the automated gate system properly maintained, and ensure that all working areas are free of debris and other effects that could compromise the gate operation and safety.
 7. On a monthly basis, check the obstruction detection system, and safety devices for correct operation.
 8. All repair, and service work to this product must be done by a suitably qualified person.
 9. This product was designed and built strictly for the use indicated in this documentation. Any other use, not expressly indicated here, could compromise the service life/operation of the product an/or be a source of danger.
 10. Centurion Systems (Pty) Ltd does not accept any liability caused by improper use of the product, or for use other than that for which the automated system was intended.
 11. Ensure that the customer is in possession of the User Guide and also complete the installation details in the back of the User Guide.

Installation Details

Installation Date:

Installer's Name:

Installer's Address:

Installer's Telephone Number: Installation Checked By:



CENTSYS



0.07.B.0032 A10
Installation Manual-10.Jul2012

www.centsys.com.au