

HOTWIRE

UNDER TILE HEATING

Hotwire Installation Manual July 2014

Please read this instruction manual. It includes important information that will assist you and save you time and money such as,

*To calculate the wire spacing start with the M2 of the area to be heated.
Multiply this by 1000. Then divide this answer by the length of the element.
The answer will be the space at which the element should be laid.*

Contents

Step 1 Read This Manual	Page 3
Step 2 Pre wire or “Rough In”	Page 3
Step 3 Cold Tail Channels	Page 4
Step 4 Floor Preparation	Page 4
Step 5 Primer	Page 4
Step 6 Cable Spacing	Page 5
Step 7 Plan the installation	Page 6
Step 8 Check the element	Page 6
Step 9 Tape	Page 7
Step 10 Roll out Element	Page 7
Step 11 Half Way	Page 7
Step 12 Nearly Finish Installing the Element	Page 8
Step 13 More Tape	Page 8
Step 14 Install the Floor Probe	Page 9
Step 15 Pull Cables to Power Supply Contents	Page 9
Step 16 Connect Continuity Alarm	Page 9
Step 17 Take a picture	Page 10
Step 18 Protecting The Element	Page 10
Step 19 Pour the Screed	Page 11
Step 20 Notice to Tilers	Page 11
Step 21 Connect The Thermostat	Page 11

Step 1 Read This Manual

Please read this manual. It includes everything you need to know to successfully install Hotwire.

Incorrect installation of Hotwire may lead to any warranty claim being denied.

In some States and Territories of Australia the installation of Hotwire Under Tile Heating must be performed in its entirety by a licensed electrical contractor. Whist in others a licensed contractor is only required for the connections to the thermostat. Please check with your local electrical authority or Electrical Contractor to verify the requirements applicable to your State or Territory.

The Hotwire element cannot be cut, shortened or lengthened in any way.

This product is Under Tile Heating and not In Screed heating. If you require In Screed Heating please contact Hotwire or your place of purchase and the correct element can be sent.

This element must be installed immediately under the tile. If a screed it being laid to create a "Fall" or is to level the floor, this element must be installed on top of the screed.

Note: Water Proofing

You can install Hotwire under or on top of the waterproofing.

However please note the following,

1) Most self levelling products cannot be

installed on top of water proofing. If unsure please contact the manufacturer of the brand you are using. If you are using Ardex products you can use Arditex NA.

2) Primer is not required over most waterproofing membranes. Please speak to your tiler or waterproofer about this. Hotwire accepts no responsibility for incorrect products used in this step.

Step 2 Pre wire or "Rough In"

Three things are required before Hotwire can be installed. Please see the diagram.

1: Power supply. You will need power capable of running the Hotwire element you are installing. Eg 800 watts

2: Flush Box. A vertically flush box will need to be installed. This is a standard light switch / power point plate.

3: Draw Wire. You will need a draw wire through the wall cavity or chased into wall (if brick) and run through conduit.

Mount Flush Box Vertically.

Provide power suitable for load of element to flush box. E.g. 800 watts

Insert draw wire from flush box to floor. This will enable you to pull the coldtails to the thermostat.

NSW: (Optional in other states) Install conduit 100 mm out onto floor and 100mm into wall cavity. Run draw wire through conduit

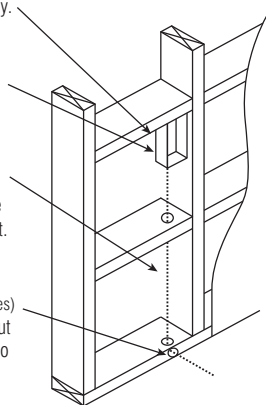

Step 3 Cold Tail Channels

Before you do too much you will need to dig out three channels for the cold tails and for the floor probe. See the pictures following.

The cold tails are conductive cables that are fitted to each end of the element. As the title says they are cold and it is this part of the cable that runs up the wall cavity. The join between the element and the cold tail is a bit thicker than the rest of the cable so you will need to dig a small channel. Your hammer drill should do the job. Each channel should be 150 mm long. The Cold Tail join must be completely buried under the tile. Failure to do so will void your warranty.



Step 4 Floor Preparation

The floor needs to be completely clean.

Sand, lumps of gyprock glue etc will affect your Hotwire installation. So make sure you clean the floor well. Sweep up all the dust, a once over with the vacuum is also a good idea if you have one handy.

Step 5 Primer

We prefer that you lay a 4mm thick self leveling screed over the element (more on that later). Fibre Glass mesh can also be used. However in either case the floor will need to be primed to assist the tiler.

You need to cover the floor well but keep in mind the thicker you do it the longer it will take to dry and the longer it will be before you can start installing Hotwire.

We recommend Ardex Multiprime.



Now you have the preliminaries done you can get down to installing Hotwire.

Step 6 Cable Spacing

This is really important to an excellent Hotwire installation, so please read this carefully.

Calculate the EXACT m² of the area to be heated. We don't normally heat under anything that is fixed. For example Vanity's, WC's in bathrooms and Kitchen Cupboards and permanent Entertainment Units in living areas.

Take the m² you are left with and multiply it by 1000 (this is to bring the measurement to square millimeters). Then divide that answer by the length of the element. This is printed on the side of the spool. The answer will be the cable spacing and should be between 50 and 75 mm. If your answer is outside this check your measurements again as you have made a mistake or have the wrong element. If this is the case do not proceed with the installation.

$$\text{Cable Spacing} = \frac{\text{M2 of floor} \times 1000}{\text{Length of Cable}}$$

The above formula is a good guide but does not take into account the loops at the end of the cable runs so take 5% off your answer. So for example if your answer was 65 mm start installing the cable at 61 mm apart.



It is a good idea to cut a jig to the size you need it rather than use a tape measure the whole time. A off cut of wood is fine, in the picture we used an off cut of electrical cable.



Note for areas over 20 m².

If your area is over 20 m² you have been supplied with two elements. These must be run in parallel and not joined together. Basically you have to install one element on one half of the floor and the other on the other half. So do the above measurement with 50% of the m².

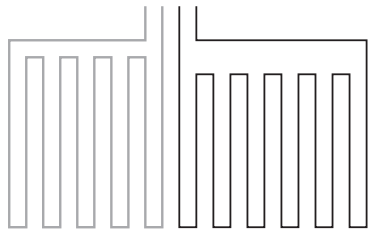

Step 7 Plan the installation

This is a step where you can come undone if you don't plan properly.

The Hotwire element must start and finish in the same place and CANNOT be cut or shortened in any way. So have a look at the room and work out what is the most logical and simple way to run the cable around that room.

You want to be doing as many long runs as possible.

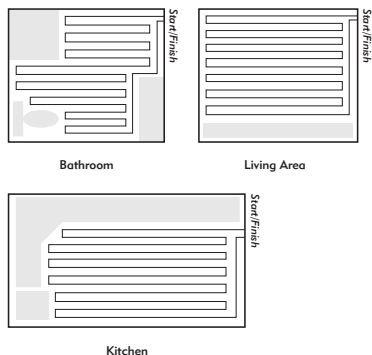

Try and leave the longest wall to last. That way if you have a little too much or too little cable left you can make an easy adjustment by coming a bit further away or going right up close to the wall. Neither option will affect the heating of the room in any way.

Step 8 Check the element

Before installing the element it is always a good idea to ensure it has not been dam-

aged during transit. We check every element before it leaves our warehouse but there is the possibility that it may get damaged by a courier.

If you have a multimeter then you can check the cable against the following table.

Watts*	Cable Length	Ohms	Amps
200	17	264.50	0.87
300	25	176.33	1.30
400	35	132.25	1.74
500	43	105.80	2.17
600	53	88.17	2.61
700	63	75.57	3.04
800	72	66.13	3.48
900	82	58.78	3.91
1000	91	52.90	4.35
1250	118	42.32	5.43
1500	141	35.27	6.52
1750	168	30.23	7.61
2000	189	26.45	8.70
2500	235	21.16	10.87
3000	294	17.63	13.04

If you don't have a multimeter don't panic we have you covered too.

In the Hotwire Box is a continuity alarm. It is a small black box with 3 cables coming off the end.

- 1: Remove small white sticker over "On / Off" Switch
- 2: Fix the Black clip to the Brown wire of the element.
- 3: Fix the Red clip to the Blue wire of the element.
- 4: Fix the Green clip to one end of the Green (earth) wire.
- 5: Switch the tester on.
- 6: A Red Light then shows that the tester is on and working.

7: If you have a fault the tester will start "Beeping"

If the alarm does not beep you are good to keep installing. There is also another use for the alarm so keep it handy, more about that after the element is down.

Step 9 Tape

You will need lots of bits of the cloth tape that it is included in the box. Rip off pieces about 60 mm long. A good rule of thumb is when you think you have enough rip off twice as much again and you should be good to go. Just stick the pieces up a door frame or window sill.



Step 10 Roll out Element

You are now ready to start rolling out the element and sticking it down.

Stick one end in the cold tail groove you cut earlier. Do not put any part of the cold tail join inside the wall cavity. It must be completely buried in the floor.



Then start spreading the element around the floor using the jig you cut earlier.

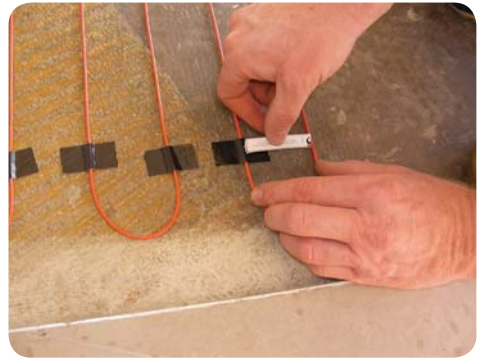

Step 11 Half Way

You will notice a half way marker. It is little piece of tape around the element. When you see this stop and look at where you are up to. If you are not sure if you are half way through the floor check your measurements. Measure the remaining m2 and use 50% of the cable length to check if you are on target. If you are a little more or under half way you can spread the cable runs out or close them up a bit. However only do this is if the difference is a mm or 2. If it is greater than this you may need to roll the cable up and change the spacing.



Step 12 Nearly Finish Installing the Element

When you are nearly finished (only 4 or 5 meters of cable left) you will need to go in reverse. Roll off all the cable and stick the second cold tail down. Then make the remainder of the element fit in the remaining space.

You may find it necessary to make one run a little shorter or close the cables up a bit. This is Okay as long as it is not a high traffic point.

In the picture you will notice the last run is a little short. This is perfectly alright as long as it is not the cable run right in front of the vanity!

If you are really stuck you can eliminate an area such as behind a door or down the sides of a Vanity unit. Just check with the homeowner to ensure they are aware so that you don't have any problems later.



Step 13 More Tape

Stick any proud bits of element down. Some of the loops may have popped up a bit. You will also need to run a strip of cable right across the whole floor to ensure the cable does not get moved when installing the leveler. It is a good idea to run right across the floor every meter.

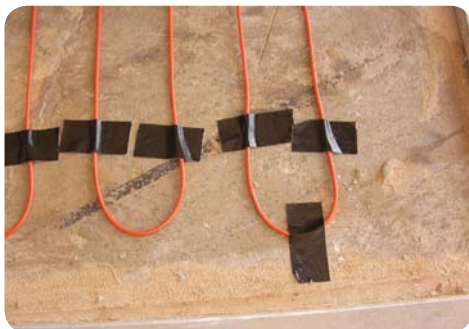

Step 14 Install the Floor Probe

You now need to install the floor probe. It should be in the box with the thermostat.

Stick the probe in the groove you cut earlier. Make sure you don't stick any tape over the end of the probe. It is also critical to ensure that the probe is exactly half way between two cable runs. If your measurement was 60 mm. Ensure the end of the probe is 30 mm from one run of element and 30mm from another.

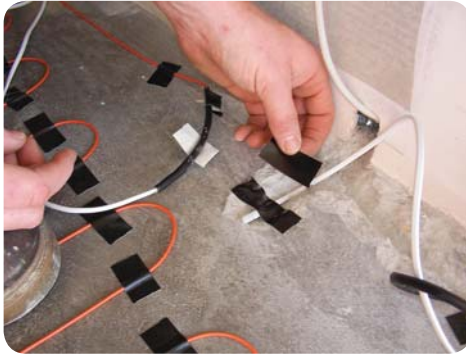

Step 15 Power Supply

Tape the ends of all three cables (each cold tail and the floor probe) to the draw wire and gently pull the cable up the wall cavity or through the conduit to the position of the power supply.

No part of the element can be run inside the wall. The entire cold tail join must be buried in the channel you dug at the start.



Step 16 Connect Continuity Alarm

Connect the continuity alarm again. This will ensure you have not damaged the cable during installation. It will also monitor the cable while you are laying the leveling compound.

- 1: Remove small white sticker over "On / Off" Switch (if you haven't already)
- 2: Fix the Black clip to the Brown wire of the element.
- 3: Fix the Red clip to the Blue wire of the element.
- 4: Fix the Green clip to one end of the Green (earth) wire.
- 5: Switch the tester on.
- 6: A Red Light then shows that the tester is on and working.
- 7: If you have a fault the tester will start "Beeping" If there is no "Beep" you can continue with the installation
- 8: If the beep sounds at any time, before or during installation STOP IMMEDIATELY as this means that damage has occurred to the element and you will need to repair it before continuing.
- 9: Once you have finished the installation and before you start tiling reconnect the tester as above & turn on.
- 10: Keep the tester on until your tiling is

complete.

11: If the tester light turns off you will need to replace the batteries.

It is a good idea to tape the alarm up with the tails so that it is not in your way while you finish the installation.



Step 17 Take a picture

Take a picture of the element layout. If there is ever a problem it will be handy to know how the element has been installed across the floor.

Step 18 Protecting The Element

There are two options for protecting the heating element.

- 1) The use of a Fibre Glass mesh
- 2) Covering the element with a self levelling compound.

Fibre Glass Mesh

Fibreglass mesh is available from Hotwire.

Please contact our office should you need supply of this product. The product is a 1000 mm x 500 mm x 50 m self adhesive fiber-glass mesh. It is simply spread out over the element and the self adhesive backing sticks to the floor and protects the element.

If using this product please ensure that you do not double one layer of mesh over another. This will stop the tile glue getting through to the floor and may cause issues with the tiles.

Please following a picture of this method used see in a living area and a bathroom.



Self Levelling Compound

When using a self levelling compound we recommend you install it to a depth of 4mm so the element is just covered.

We also recommend you use, LQ92 by Ardex.

Please refer to the instructions on the packaging. Briefly they are as follows,

- 1: Put EXACTLY 4 l of water in a clean bucket.
- 2: Pour in 50% of the bag
- 3: Mix until all the powder is gone
- 4: Pour in the remainder of the powder.
- 5: Mix until all the powder is gone.

The consistency should be something like a thick gravy or a runny custard.

Step 19 Pour the Screed

Pour the screed in the furthest corner from the door and work your way out of the room.



Using a flat trowel spread the leveling. It should be very easy to push and will find its own level. To protect the cable ensure you only move the trowel along the cable and not across it. You can use the top of the cables as a guide for the depth. The outline of the cables will be visible in the finished product.



Admire your work. You have just installed Hotwire.

Step 20 Notice to Tilers

Inside this manual is a yellow flier pointing out to tilers that Hotwire has been installed. Stick it to the wall in a prominent place. The flier also has a place to write your name and number for them to call with any questions.

Step 21 Connect the Thermostat

It is a good idea to leave the continuity alarm connected during the tiling. This will ensure that any damage is noticed immediately. It will involve either a second trip to connect the thermostat or leaving the connection to the second fix electrician.

Should your system be larger than 1 element you will need to connect the 30 amp relay as follows,

Wiring:

- 1: Switch supply from the thermostat to terminal "A"
- 2: Neutral to terminal "B"
- 3: Supply active to terminal "3"
- 4: Load to be switched (Hotwire Element) to terminal "4"
- 5: Relay can be installed in the roof cavity or in the switch board.

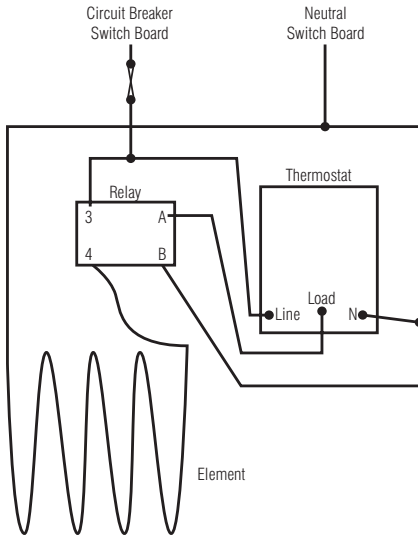

Materials Check List

Provided from Hotwire:

Hotwire Element:
Thermostat: (including a floor sensing probe)
Cloth Tape
Continuity Alarm
This Manual
Relay if required

You will also need,

Broom
Hammer Drill
Bucket
Mixer
Flat trowel
Tape Measure
Screed
Primer

Tilers instructions

It is the Tiler's responsibility to check the floor for suitability for tiling and to complete any floor preparation and waterproofing etc required before the heating element is installed.

The heating element incorporates double insulation with a multi stranded conductor and will withstand normal tiling practices. However we do ask you to note and take care of the following.

A latex modified (acrylic, PVA, SBR) cement based grout must be used, with at least a 10-15% "by weight of solid base" latex content. Wear soft soled shoes while tiling.

Ensure that enough adhesive is used to eliminate hollows or voids under the tiles.

Do not carry other work on top of the elements such as tile cutting.

Do not place ladders on the elements.

Close off the area to other trades before the tiling has taken place.

We recommend a 10mm plastic notched trowel be used to spread adhesive and that trowelling is done in the direction of the element wire. (If steel trowel is used check for

any sharp edges which should be filed and removed).

Do not position tiles or other machinery on the heated floor area, and care must be taken not to drop anything.

Electrical Connection of the Thermostat

All circuit wiring supply and thermostat connection must be undertaken in accordance with the current electrical standards and regulations. The heating units must be separated from other heating sources.

The maximum thermal resistance between the heating element and the room = 0.4 m sq K/w All electrical supply circuits must be RCD (Residual Current Device) protected with a rated residual operation current not exceeding 30 mA.

Operation

Wait 7 days for the tile adhesive to dry before you turn your heating on. Once the heating is commissioned the initial heat up time will vary depending on the sub floor type, (concrete or timber) insulation, thermal characteristics and ambient temperature. Performance will improve with use.

Do's and Don'ts

DO's

Carefully read the installation instructions prior to commencing your installation.

Check the element is working before you

start.

Ensure the surface is clean and clear of obstructions.

Pre plan your element layout and stay with the recommended element spacing.

Maintain even element spacing.

Protect the heating element from damage at all times.

Plan required pre work and drilling before you lay the element.

Take care when tiling to make sure that you do not damage the element.

Ensure that enough tile adhesive is used so not to leave gaps or voids under the tiles.

DON'Ts

Don't cut or shorten the heating element.

Don't commence installation on concrete floors that are not fully cured.

Don't allow the heating elements to cross or touch.

Don't allow traffic over the heating element until the flooring has been laid.

Don't remove the heating element off the spool except during installation.

Don't store tiles sharp or heavy objects on the elements while tiling.

Don't switch on the heating until the tile adhesive has fully cured. Don't install the element over uneven floor surfaces.

Footnotes

The lowest ambient temperature that the heating element can be installed equals -80C

The minimum radius for bending the heating element equals 20 mm.

The thickness of covering materials should be at least 5mm.

Contact the manufacturer for advice if materials other than those recommended are used.

The appliance is not intended for use by young children, or infirm persons, without supervision.

Young children should be supervised to ensure they do not play with the appliance. Laws in different states and territories of Australia differ. Please check with your local electrical authority if someone other than a licensed Electrician is able to lay the cable in your state or territory. In all states and territories all electrical connections including the thermostat must be carried out by a registered electrician.

All circuit wiring supply and thermostat connection must be undertaken in accordance with the current electrical standards and national wiring regulations.

The heating units must be separated from other heat sources.

Customer Warranty for Hotwire Products

1) General

- a) These terms and conditions (**Terms and Conditions**) apply to each contract for the supply of goods (**Goods**) by or on behalf of Turnkey International Pty Ltd ABN [36 086 830 766] trading as Hotwire Heating (**Hotwire**) to any customer (**Customer**) by purchase through an authorised distributor of Hotwire or otherwise.

2) Terms and Conditions

- a) A contract for the supply and purchase of Goods (**Contract**) will be formed, on these Terms and Conditions, immediately when the Customer purchases the Goods from Hotwire (or an authorised distributor of Hotwire) or where the Customer otherwise requests that Goods be supplied by Hotwire to the Customer.
- b) No additional terms and conditions, whether contained in or deemed to be incorporated by any other order or quotation (if any) of the Customer, will apply in substitution of these Terms and Conditions nor will they in any way override or amend these Terms and Conditions.
- c) A Customer must not cancel any order for Goods or terminate a Contract without the prior written consent of Hotwire. The Customer must indemnify Hotwire for all costs, expenses and losses incurred as a result of that cancellation or termination.

3) Installation Manual

- a) The Hotwire installation manual (**Installation Manual**) is provided for the benefit of the Customer only and is not a complete guide as to proper installation of the Goods. The Goods and installation of the Goods ordinarily requires the technical skills of a qualified installer. Do not take any steps to install the Goods without a copy of the Installation Manual.

4) Risk and ownership of Goods

- a) Risk of loss, or damage, to the Goods passes to the Customer on delivery which will occur on the earliest of the following events:
 - i) The Customer taking possession of the Goods from Hotwire premises or the premises of an authorised distributor;
 - ii) Completion of the loading of the Goods onto a transportation vehicle provided by the Customer; or
 - iii) Delivery by Hotwire to any location nominated by the Customer,

(Delivery).

- b) Ownership of, and title to, the Goods passes to the Customer only upon payment in full by the Customer of the purchase price for the Goods and any other amounts due by the Customer to Hotwire.
- c) Until payment of the purchase price for the Goods (in full):
 - i) Hotwire retains full legal title to the Goods;
 - ii) If the Goods are in the Customer's

possession, the Customer will hold the Goods as bailee for Hotwire and must store the Goods so that they are clearly identifiable as the property of Hotwire;

- iii) Hotwire may call for, and recover possession of, the Goods at any time; and
- iv) the Customer must at its own cost, deliver the Goods to Hotwire if requested to do so by Hotwire.

5) Damaged or missing Goods

- a) Any claim in respect of a shortage of Goods or damaged Goods (**Claim**) must be lodged with Hotwire within five (5) business days of the Delivery of some or all of the goods the subject of the Contract.
- b) Failure by the Customer to give notice of a Claim within five (5) business days of the Delivery of some or all of the Goods the subject of the Contract to Hotwire will be deemed an absolute and unconditional waiver of such Claim.

6) Installation

- a) Hotwire recommends that the Goods be installed by a registered Hotwire Installer (**Authorised Installer**).
- b) Any installation by a person who is not an Authorised Installer must be carried out strictly in accordance with the Installation Manual taking into account the individual circumstances of the place of installation and a failure to do so may void or exclude your ability to claim under the Warranty.

7) Warranty

- a) Subject to clause 7(b), Hotwire undertakes to repair or at its sole discretion replace any

part of the Goods specifically manufactured by Hotwire which is found to have a manufacturing defect for a period of ten (10) years from the date of Delivery.

- b) The period of the Warranty described at clause 7(a) does not apply to the part of the Goods comprising (or being) the thermostat and the controller. The Warranty period in relation to those parts of the Goods is limited to two (2) years.

(Warranty)

8) Exclusion and Limitation of Liability

- a) Except for:
 - i) Any implied condition or warranty the exclusion of which would contravene any statute or cause any part of this clause to be void; and
 - ii) The Warranty,

Hotwire excludes all other conditions and warranties implied by custom, the general law or statute.

- b) The Warranty does not apply if:
 - i) Unauthorised repairs or alterations are made to the Goods;
 - ii) The Customer fails to comply with all instructions of Hotwire (whether written or verbal) in relation to the fitting, installation and use of the Goods;
 - iii) The Goods are subjected to improper voltage or power surges, misused, damaged by accident, force of nature or any other acts beyond Hotwire's reasonable control; and/or

- iv) The Goods are improperly installed or installed other than strictly in accordance with the Installation Manual (other than where such improper or other installation is carried out by an Authorised Installer).
- c) The Warranty does include calls to replace batteries, programme or re-programme thermostats and/or controllers, replace fuses or reset residual current devices or circuit breakers.
- d) The total maximum liability of Hotwire under the Warranty is limited to replacing the Goods, repairing the Goods or payment of the replacement cost of the Goods.
- e) Hotwire will not be liable for any personal injury, incidental damages, consequential losses, loss of profit, costs of business interruption, loss of opportunities or any like claims whatsoever arising from any use of, or incidental to, the Goods or their failure to operate, or arising out of Hotwire's negligence or breach of the Contract.
- f) If any component part of the Goods is manufactured by a third party or supplied to Hotwire by a third party, any warranty offered by Hotwire in relation to the Goods or a component part of the Goods will be limited to Hotwire's right of redress (if any) against the manufacturer or supplier of the component part of the Goods.
- g) The Customer must keep Hotwire indemnified against:
 - i) All claims, expenses and liabilities of whatever nature including but not limited to loss of profit, which may be made against or which Hotwire may sustain, pay or incur arising out of the manufacture or sale of the Goods to the Customer, except in so far as the same arises from Hotwire's negligence or breach of the Contract; and
 - ii) Hotwire's costs in attending to a Warranty call by a Customer which is without merit, excluded by this clause or where no Warranty is otherwise available to the Customer together with its costs of defending any such claim by a Customer against Hotwire (including legal costs incurred by Hotwire).
- h) This clause does not exclude or limit the application of any statutory provision where to do so would contravene that statute or cause any part of this clause to be void.

18-20

Hotwire (Australia Head Office)
Po Box 543,
Mount Evelyn Vic 3796

Phone 1300 797 060
Fax +61 (03) 8678 1337
www.hotwireheating.com.au

HOTWIRE
UNDER TILE HEATING

1300 797 060
hotwireheating.com.au

20-20

Hotwire (Australia Head Office)
Po Box 543,
Mount Evelyn Vic 3796

Phone 1300 797 060
Fax +61 (03) 8678 1337
www.hotwireheating.com.au

HOTWIRE
UNDER TILE HEATING